

TITAN 110/ 165 OPERATION & MAINTENANCE MANUAL

© November 2000 GBC Films Group
Do not duplicate without written permission.

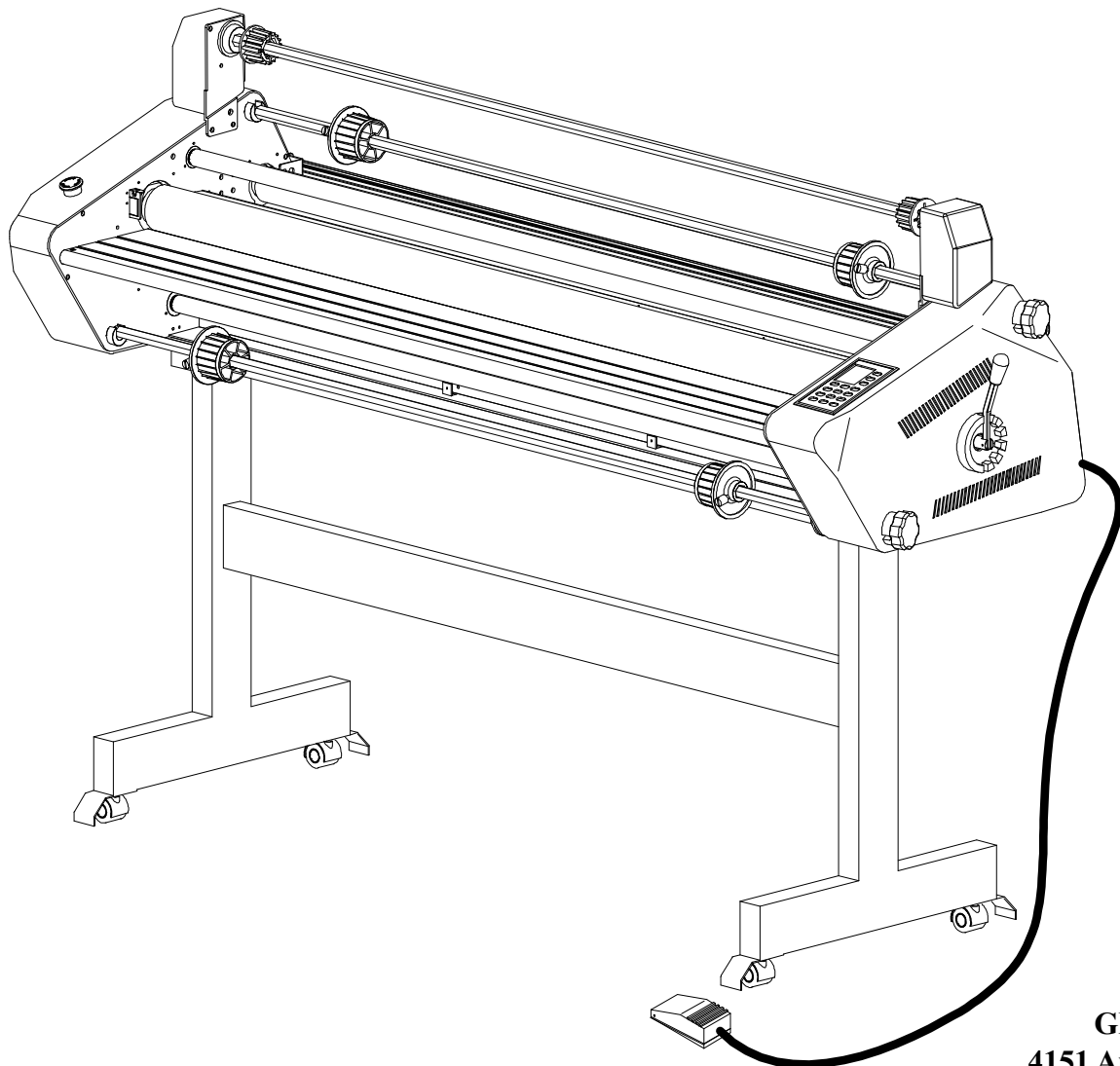

Revision : B (03/20/03)
Part number : 930 - 046

GBC Pro - Tech
4151 Anderson Road
DeForest, WI 53532
Ph: (608) 246 - 8844
Fx: (608) 246 - 8645







Read Me File

The information in this publication is provided for reference and is believed to be accurate and complete. GBC Films Group is not liable for errors in this publication or for incidental or consequential damage in connection with the furnishing or use of the information in this publication, including, but not limited to, any implied warranty of fitness or merchantability for any particular use.

GBC Films Group reserves the right to make changes to this publication and to the products described in it without notice. All specifications and information concerning products are subject to change without notice.

Reference in this publication to information or products protected by copyright or patent does not convey any license under the rights of GBC Films Group or others. GBC Films Group assumes no liability arising from infringements of patents or any other rights of third parties.

This publication is copyrighted © 2000 by GBC Films Group. All rights reserved. The information contained in this publication is proprietary and may not be reproduced, stored, transmitted, or transferred, in whole or in part, in any form without the prior and express written permission of GBC Films Group.

The following information will explain how to move around within the electronic version of this publication. The hand will change to a pointer finger identifying hyperlinked areas. When moving from page to page, use  to return to the **first PAGE**, use  to advance to the **last PAGE**, use  to **go back one PAGE** and use  to **advance one PAGE**. When moving from view to view, use  to **return** to a previous **VIEW** and use  to **advance** to the next **VIEW**.

Should you find an error within this publication or would like to make a suggestion, please utilize the fax correspondence sheet following this read me file and fax it to the number provided. Your comments and help will ensure up to date information. Thank you.

This page intentionally left blank.

Fax Correspondence

Fax number : (608) 246 - 8645

Date : _____

To : Sean Flood at GBC Pro-Tech
4151 Anderson Road
DeForest, WI 53532

From : _____

Company : _____

Address : _____

Phone number : (_____) _____ Fax number : (_____) _____

Re : Titan 110/ 165 Operations and Maintenance Manual (930046 Rev A)

Section #: _____ Page #: _____

Correction (s): _____

Additional comments: _____

This page intentionally left blank.

Table of Contents

Section 1: Safety

1.1 Symbols	1 - 1
1.2 Safety features	1 - 2
1.3 Installation	1 - 4
1.4 Operations	1 - 8
1.5 Applications	1 - 11
1.6 Troubleshooting	1 - 13
1.7 Maintenance	1 - 13
1.8 Label Explanation	1 - 16
Figure 1.8.1 Label Location	1 - 17

Section 2: Warranty

2.1 Limited warranty information	2 - 1
2.2 Exclusions to the warranty	2 - 1

Section 3: Specifications

3.1 General	3 - 1
3.2 Consumables.....	3 - 2
3.3 Function	3 - 3
3.4 Electrical	3 - 3
3.5 Dimensions	3 - 5

Section 4: Installation

4.1 Pre-installation check list	4 - 1
Figure 4.1.1 Connections Titan 110	4 - 2
Figure 4.1.2 Connections Titan 165 - U.S.	4 - 2
Figure 4.1.3 Connections Titan 165 - Europe	4 - 2
Figure 4.1.4 Suggested floor layout- Titan 110.....	4 - 3
Figure 4.1.5 Suggested floorer layout- Titan 165	4 - 4

4.2 Know your machine	4 - 5
4.3 Unpacking	4 - 7
4.4 Shrink wrap	4 - 7
4.5 Crated	4 - 8
4.6 Safety check	4 - 10
4.7 Control panel check	4 - 13
4.8 Roller handle	4 - 17
4.9 Film brake adjustment	4 - 18
4.10 Rear cut-off blade	4 - 19

Section 5: Operations

5.1 Control panel	5 - 1
5.2 Emergency	5 - 6

5.3 Safety shield5 - 3

5.4 Pressure plate5 - 9

5.5 Feed table5 - 10

5.6 Film loading5 - 11

5.7 Film alignment5 - 14

5.8 Change nip5 - 15

5.9 Rear cut-off5 - 16

5.10 Job programming5 - 17

Section 6: Applications

6.1 Pressure sensitive6 - 1

6.2 Mounting6 - 5

6.3 Encapsulation6 - 8

Figure 6.1.1 Poly-in/ Poly-out6 - 13

Section 7: Troubleshooting

7.1 Wave problems7 - 1

7.2 Troubleshooting chart7 - 4

Section 8: Maintenance

8.1 Maintenance schedule8 - 1

8.2 Cleaning the rollers8 - 2

8.3 Clean the cabinets and covers8 - 7

8.4 Cleaning the control panel8 - 8

This page intentionally left blank.

Section 1 Safety



CAUTION

Do not attempt to operate your Titan 110/ 165 laminator until you have read this section carefully!



CAUTION

Indicates a potentially hazardous situation which, if not avoided, could result in minor or moderate injury, or alerts against unsafe practices or alerts against actions which could damage the product.

Your safety, as well as the safety of others, is important to GBC Films Group. This section contains important safety information.



WARNING

Indicates a potentially hazardous situation which, if not avoided, could result in serious injury.

The following symbols are used throughout this manual to indicate **Information**, **Caution**, **Warning**, **Danger** and **Electrical Shock** conditions.



DANGER

Indicates an imminently hazardous situation which, if not avoided, could result in death or serious injury.

1.1 Symbols



INFORMATION

Indicates helpful information that should be considered before, during, or after an action, step or procedure is given.



ELECTRICAL SHOCK

Indicates an electrical shock situation which, if not avoided, could result in serious paralysis of the body or death.

1.2 Safety features

The Titan 110/ 165 laminator has been designed with safety as a primary consideration; however, you must become thoroughly familiar with the controls, proper operation, proper service procedures and safety features of the laminator before using or servicing the unit.

In addition, the heating components of the Titan 110/ 165 can reach temperatures of over 200 °F (100 °C).



DANGER

At these temperatures there is a danger of severe burn if the rolls are touched during setup, operation or servicing.



INFORMATION

Only a qualified service technician should perform any procedure requiring the cabinet doors to be opened.



WARNING

Caution should always be exercised when using the laminator with the safety shields raised.
You can be seriously HURT or INJURED!

Qualified ;

- Any engineer that has experience with electrical and mechanical design of lamination equipment. The engineers should be fully aware of all aspects of safety with regards to lamination equipment.

- Any commissioning or service engineer must be of competent nature, trained and qualified to GBC Films Group standards to fulfill that job. This person will have completed and passed the full service training course from GBC Films Group.

- Any GBC Technician, GBC Specialist, and / or GBC Films Group Technician that has been through the GBC Pro-Tech service training course.

An important feature of the Titan 110/ 165 laminator are the safety latches and the interlocks. The front safety shield (**Figure 1.2.1**) and the feed table (**Figure 1.2.2**) are both equipped with safety latches. When a safety latch is not in the locked position, the motor is disabled.

The word qualified is defined as;

Figure 1.2.1 Safety shield



Figure 1.2.3 Emergency stops

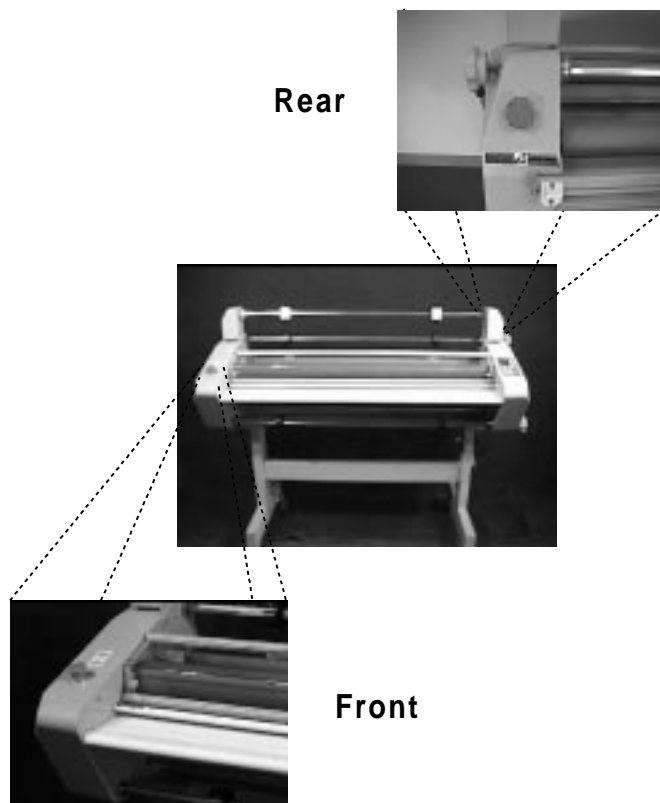
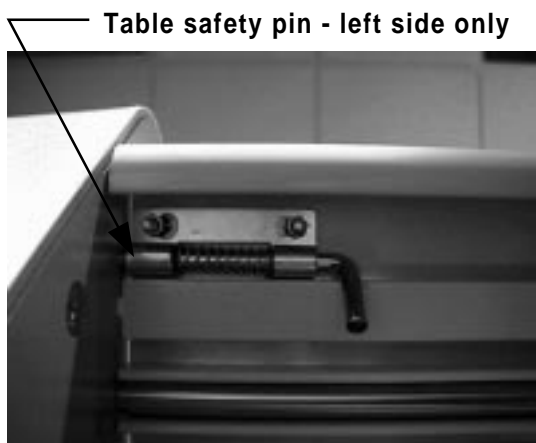
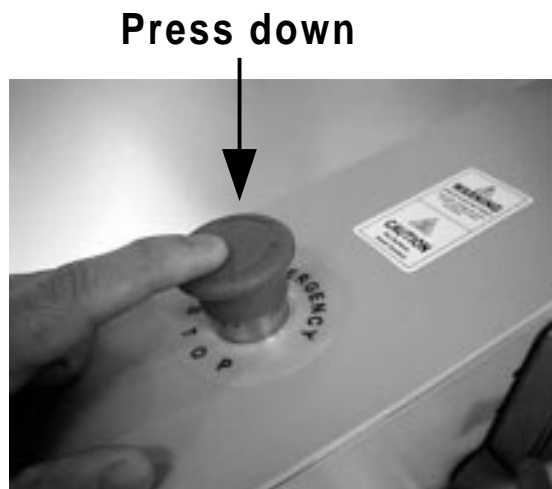

Figure 1.2.2 Feed table



To engage the **EMERGENCY STOP** feature, press down. Either of these, when engaged, removes power to the motor.

The laminator is equipped with two **EMERGENCY STOPS (E-STOP)**. One is located on the left side from the front operating position and the second is located above machine **POWER**. Refer to **Figure 1.2.3**



To continue operation, both **E-STOPS** must be in the up position. To reset the **E-STOP**, twist the button 1/4 turn clockwise.

1.3 Installation

The following symbols are positioned at various points in **Section 4 Installation**.

Rotate 1/4 turn



CAUTION

Failure to follow the pre-installation check list can result in damage to the laminator.



INFORMATION

The laminator will operate only when all safety latches are in the fully latched position.



WARNING

The operating environment must be free of dust, flammable liquids and vapors. You can be injured by inhaling chemical vapors.



WARNING

Vapor build up or stored flammable liquids can cause a fire. Excessive dust can damage the laminator.

**CAUTION**

Do not locate the laminator where air is blowing directly on the machine. The air flow can cool the rollers unevenly and result in poor quality output.

**INFORMATION**

Before signing the Bill of Lading, you should be sure to inspect the crate and / or pallet for signs of damage or missing items; if applicable, make note of this on the Bill of Lading.

**INFORMATION**

Depending on the destination and customer preference, the Titan 110/ 165 may be shipped in various ways. The laminator may arrive shrink wrapped or in a plywood crate on a skid. Please follow the unpacking procedure that pertains to your method of shipment.

**WARNING**

The Titan 110/ 165 Laminator is a large and heavy piece of equipment. It is necessary to employ **LICENSED RIGGERS ONLY** to move the laminator. The laminator is not designed to be tipped up or sideways in any way. Such action disturbs the exact alignment of the rolling parts of the machine and requires extensive realignment. You can be crushed or seriously injured.

**CAUTION**

Do not use a knife or other sharp object to remove the shrink wrap from around the laminator. You can cause irreparable damage to the rollers.

**INFORMATION**

ALL SHIPMENTS ARE EX-WORKS. At our dock, title passes to the buyer. Please review your insurance coverage prior to shipment, as you are responsible for all subsequent freight charges and risks.

**WARNING**

Do not attempt to move the laminator across anything other than a flat level surface without trained and qualified riggers. You can be crushed or seriously injured.

**WARNING**

The unpacking process requires at least two people. You can be severely injured, crushed or cause damage to the laminator.

**INFORMATION**

GBC Films Group's warranty does not cover malfunction of the equipment due to mishandling and / or tipping. GBC Films Group bears no responsibility for personal injury or damage due to moving the laminator improperly.

**CAUTION**

Do not allow the top to fall into the crate. It can damage the laminator.

**INFORMATION**

About recycling: The crate components can be reused for shipping the laminator again or can be disassembled and the wood and screws recycled. The shrink wrap is not recyclable, so it must be discarded.

**INFORMATION**

Do not put packing screws on the floor. They can cause problems when trying to roll the laminator into position or you can become injured if stepped on.

**WARNING**

Do not wear ties, loose fitting clothes or dangling jewelry while operating or servicing the laminator. These items can get caught in the nip and choke you or you can be crushed or burned.

**CAUTION**

A second person must support the side labeled 5 in Figure 4.5.1 It can fall and damage the laminator or cause harm to you and others.

**WARNING**

If a safety feature is not functioning properly, contact your local service representative immediately

**DANGER**

At no time should you attempt to over ride any of the safety latches on the laminator.

**INFORMATION**

When any command is pressed on the control panel, an audible "beep" will be heard for each increment of change or each press.

**INFORMATION**

The laminator will operate only when all safety latches are in the fully latched position.

**INFORMATION**

Top and bottom set points are intentionally left at 320 °F (160 °C) for now.

**INFORMATION**

Locator pins on the pressure plate are not associated with an interlock switch. The laminator can operate without the pressure plate installed.

**WARNING**

Keep hands and fingers clear of the laminator roller nip when changing GAP. You can be CRUSHED or BURNED!

**WARNING**

Caution should always be exercised when using the laminator with the safety shields raised. You can be seriously HURT or INJURED!

**CAUTION**

Never leave the rollers in the down position without rolling. Prolonged contact in one area can form flat spots on the rollers.

1.4 Operations



WARNING

Extreme caution should always be exercised working around the core gripper support, the gripper tabs can cut you!

The following symbols are positioned at various points in **Section 5 Operations**.



WARNING

Caution should always be exercised when using the rear cut-off blade. Sharp objects can cut you!



WARNING

Do not wear ties, loose fit clothing or dangling jewelry while operating or servicing the laminator. These items can get caught in the nip and choke you or you can be crushed or burned.



WARNING

Keep hands and fingers away from the path of the rear cut-off blade. Sharp objects can cut you!



INFORMATION

The laminator will operate only when all safety latches are in the fully latched position.



INFORMATION

Job programming is explained in Section 5.7

**INFORMATION**

If **COOLING** is illuminated, the cooling fans are in the "on" position.

**INFORMATION**

When an **EMERGENCY STOP** is engaged, all motion stops. The nip will not change from the operating setting.

**INFORMATION**

Reverse speed is preset at 1 meter/ minute.

**INFORMATION**

When the **E-STOP** is disengaged, the rollers will begin turning. By pressing stop first, The rollers will not turn until **RUN** is pressed

**INFORMATION**

When the set point value is higher than actual temperature, " **WAIT** " is indicated at the bottom of the display.

**INFORMATION**

The Temperature control panel settings are not affected when an **E-STOP** has been pushed.

**INFORMATION**

When the input value for **JOB** is changed, the parameters stored within that number are displayed.

**WARNING**

Caution should always be exercised when using the laminator with the safety shields removed.
You can be seriously HURT or INJURED!

**DANGER**

At no time should you attempt to over ride any of the safety latches on the laminator.

**WARNING**

Extreme caution should always be exercised working around the 3 inch core grippers, the gripper tabs can cut you!

**INFORMATION**

All E-STOPS must be unlatched, safety shield fully closed and feed table properly installed before operating.

**CAUTION**

Ensure the roll of laminate is loaded properly on the unwind shaft. Exposed adhesive should be facing away from the heated components. This will prevent hours of cleaning!

**INFORMATION**

Locator pins on the pressure plate are not associated with an interlock switch. The laminator can operate without the pressure plate installed.

**INFORMATION**

For core grippers, turning the roll film in the same direction as the gripper tabs while sliding makes loading the film onto the unwind shaft easier.

**WARNING**

Extreme caution should always be exercised when removing an unwind shaft, the gripper tabs can cut you!

**WARNING**

Keep hands and fingers clear of the laminator roller nip when changing GAP. You can be CRUSHED or BURNED!

**CAUTION**

Never leave the rollers in the down position without rolling. Prolonged contact in one area can form flat spots on the rollers.

**WARNING**

Keep hands and fingers away from the bottom of the rear cut-off blade. Sharp blade can cut you!

**WARNING**

Caution should always be exercised when using the rear cut-off blade. Sharp blade can cut you!

1.5 Applications

The following symbols are positioned at various points in **Section 6 Applications**.

**CAUTION**

Stop the laminator before using the rear cut-off blade. Moving material can damage the rear cut-off blade!

**WARNING**

Do not wear ties, loose fit clothing or dangling jewelry while operating or servicing the laminator. These items can get caught in the nip and choke you or you can be crushed or burned.

**WARNING**

Keep hands and fingers away from the path of the rear cut-off blade. Sharp blade can cut you!

**INFORMATION**

The Titan 110 is used for illustration purposes. The procedure is the same for the Titan 165.

**CAUTION**

Ensure the roll of laminate is loaded properly on the unwind shaft. Exposed adhesive should be facing away from the heated components. This will prevent hours of cleaning!

**INFORMATION**

The Titan 110 is used for illustration purposes. The procedure is the same for the Titan 165.

**WARNING**

Caution should always be exercised when using the laminator with the safety shields removed. You can be seriously **HURT** or **INJURED**!

**INFORMATION**

Avoid tacking at the ends first and pressing towards the center, you may create a tunnel once you have reached the center. This will make for a difficult mounting application.

**WARNING**

Keep hands and fingers clear of the laminator roller nip when changing GAP. You can be **CRUSHED** or **BURNED**!

**CAUTION**

Do not use the rear cut-off blade to trim the substrate! You can damage the blade.

**INFORMATION**

Speed can be increased during operation.

**CAUTION**

Ensure the roll of laminate is loaded properly on the unwind shaft. Exposed adhesive should be facing away from the heated components. This will prevent hours of cleaning!

**INFORMATION**

The temperature may differ with regards to your laminate. The temperature used is for instructional purposes only.

1.7 Maintenance

The following symbols are positioned at various points in **Section 8 Maintenance**.

**WARNING**

Keep hands and fingers away from the heat rollers.
You may be **BURNED!**

**WARNING**

Do not wear ties, loose fitting clothes or dangling jewelry while operating or servicing the laminator. These items can get caught in the nip and choke you or you can be crushed or burned.

**INFORMATION**

Use the appropriate diagram for the type of film you are using.

**INFORMATION**

Improper maintenance, can result in poor output quality.

1.6 Troubleshooting

The following symbols are positioned at various points in **Section 7 Troubleshooting**.

**INFORMATION**

Below is a recommended maintenance schedule. Before performing any of the steps listed, read through the procedures first. Please follow the instructions pertaining to the step you are performing.



ELECTRICAL SHOCK

Remove power from the laminator before servicing. You can be severely shocked, killed or cause a fire.



CAUTION

Harden adhesive deposits on the rollers can cause damage to the rollers.



CAUTION

The following procedure is performed while the laminator is HOT!
Use extreme caution!



CAUTION

Do NOT pick or pull heat activated adhesive off the rolls when they are cold. You can cause irreparable damage to the laminating rolls.



WARNING

Heating components are HOT!
You can become severely burned !



INFORMATION

The most efficient time to clean the rollers is after a lamination process is completed.



CAUTION

Never clean the rollers with sharp or pointed objects. You may put irreparable cuts into the rollers.



INFORMATION

The laminator will operate only when all safety latches are in the fully latched position.

**INFORMATION**

If the rolls are heated, proceed to
Removing adhesive build up..

**INFORMATION**

Rollers only turn in reverse while
depressing  .

**WARNING**

Caution should always be exercised
when using the laminator with
the safety shields raised.
You can be seriously **HURT** or **INJURED!**

**ELECTRICAL
SHOCK**

Do not use liquid or aerosol cleaners on the
laminator. Do not spill liquid of any kind on
the laminator. You can be severely shocked,
killed or cause a fire. Use only a damp cloth
for cleaning unless other wise specified.

**CAUTION**

Excessive pressure can destroy the silicone
layer by pressing to hard or scrubbing
too long in one spot.

**ELECTRICAL
SHOCK**

Do not use liquid or aerosol cleaners on the
laminator. Do not spill liquid of any kind on
the laminator. You can be severely shocked,
killed or cause a fire. Use only a damp cloth
for cleaning unless other wise specified.

**INFORMATION**

Locator latches on the pressure plate are
not associated with an interlock switch.
The laminator will operate without
the pressure plate installed.

1.8 Label Explanations

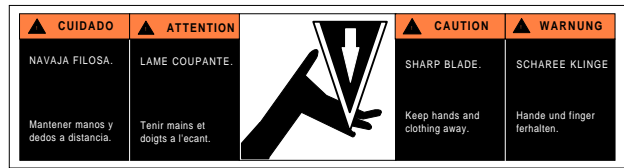

Posted at various locations on the Titan 110/ 165 Laminator are important safety labels. **Pay careful attention to these labels at all times!** Figure 1.8.1 illustrates the location of each of these labels.

(1) SHARP BLADE: Sharp blade comes down. Keeps hands and fingers away.

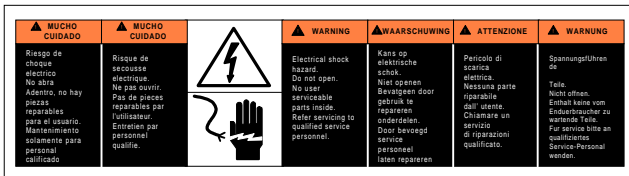

(3) ELECTRICAL SHOCK: Electrical shock hazard. Electrical voltage behind panel.

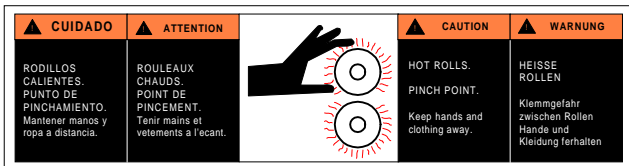

(2) Roller Pinch Point: Keep hands and fingers away. You may be crushed and/ or burned.

Figure 1.8.1 Label placement

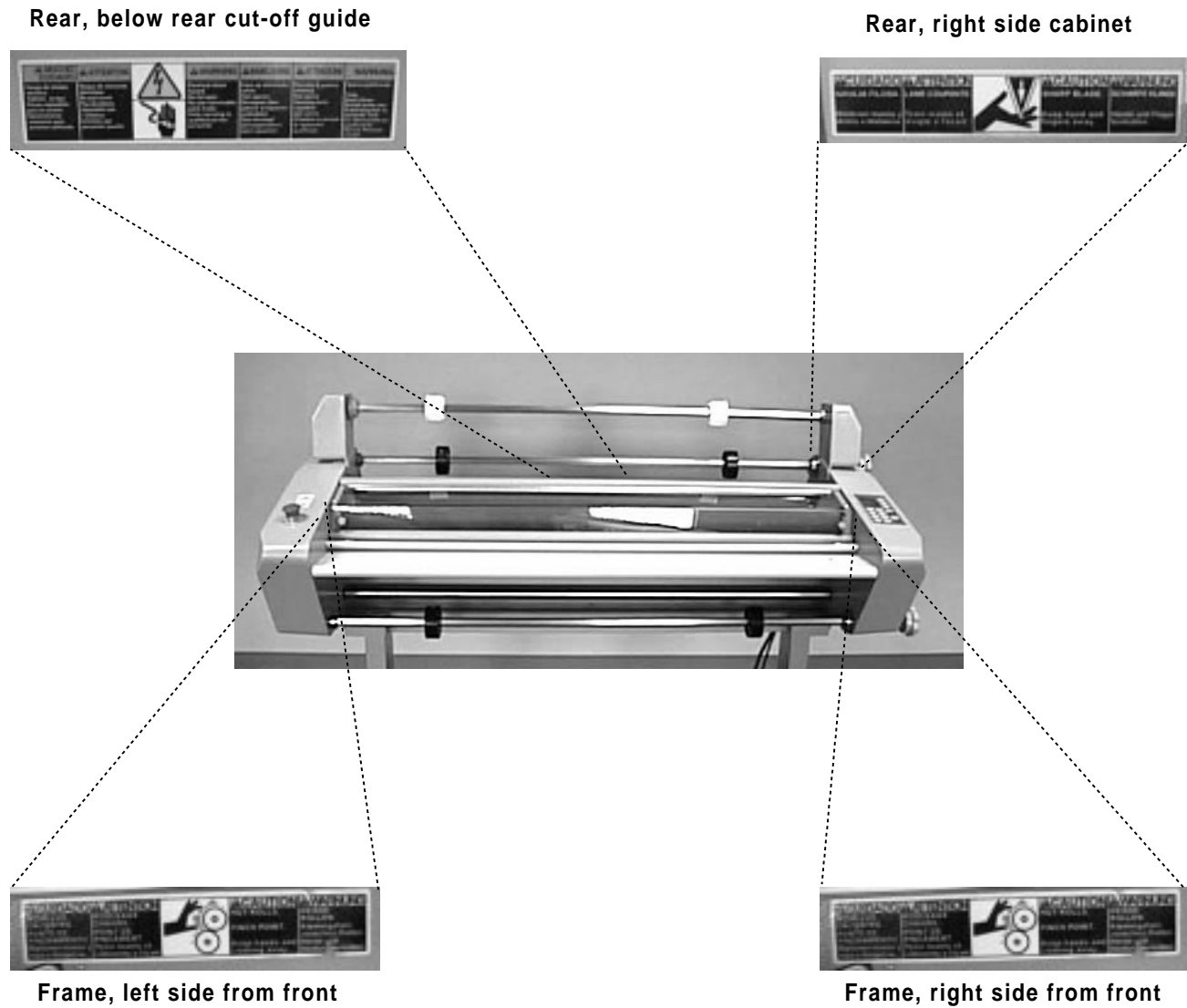

This page intentionally left blank.

Section 2 Warranty



CAUTION

Unauthorized customer alterations will
void this warranty.

GBC Films Group warrants the equipment sold is free from defects in material and workmanship for a period of **one (1) year parts and 90 days labor** from the date of installation. This warranty is the only warranty made by GBC Films Group and cannot be modified or amended.

GBC Films Group's sole and exclusive liability and the customer's sole and exclusive remedy under this warranty shall be, at GBC Films Group's option, to repair or replace any such defective part or product. These remedies are only available if GBC Films Group's examination of the product discloses to GBC Films Group's satisfaction that such defects actually exist and were not caused by misuse, neglect, attempt to repair, unauthorized alteration or modification, incorrect line voltage, fire, accident, flood, or other hazard.

THE WARRANTY MADE HEREIN IS IN LIEU OF ALL OTHER WARRANTIES, EXPRESS OR IMPLIED, INCLUDING ANY WARRANTY OR MERCHANTABILITY OR FITNESS FOR A PARTICULAR PURPOSE. GBC PRO-TECH WILL NOT BE LIABLE FOR PROPERTY DAMAGE OR PERSONAL INJURY (UNLESS PRIMARILY CAUSED BY ITS NEGLIGENCE), LOSS OF PROFIT OR OTHER INCIDENTAL OR CONSEQUENTIAL DAMAGES ARISING OUT OF THE USE OR INABILITY TO USE THE EQUIPMENT.

2.1 Limited Warranty

This warranty specifically does not cover damage to the laminating rollers caused by knives, razor blades, other sharp objects, failure caused by adhesives or improper use of the machine. Warranty repair or replacement does not extend the warranty beyond the initial one year period from the date of delivery.

2.2 Exclusions to the Warranty

This warranty specifically does not cover;

1. Damage to the laminating rolls caused by knives, razor blades, other sharp objects or failure caused by adhesives.

2. Damage to the machine caused by lifting, tilting and/or any attempt to position the machine other than rolling on the installed castors on even surfaces.

3. Improper use of the machine.

4. Damage due from unqualified person(s) servicing the machine.

Qualified

- Any engineer that has experience with electrical and mechanical design of lamination equipment. The engineers should be fully aware of all aspects of safety with regards to lamination equipment.

- Any commissioning or service engineer must be of competent nature, trained and qualified to GBC Pro-Tech standards to fulfill that job. This person will have completed and passed the full service training course from GBC Pro-Tech.

- Any GBC Technician, GBC Specialist, and / or GBC Pro-Tech Technician that has been through the GBC Pro-Tech service training course.

Section 3: Specifications

Specifications provide all of the technical data for the Titan 110/ 165 Laminator. All specifications refer to both the Titan 110 and Titan 165, U.S. and Europe, unless otherwise specified.

Section 3.1 General

Description:

- A high speed laminator for the graphic arts professional as well as the manufacturer who produces promotional pieces in-house. A laminator with elegant design, low power consumption and first class safety and quality assurances.

Features:

- Roller heating technology
- Independent control of each heat roller
- Thermal and cold lamination capabilities
- Unique vented cooling system
- Mounting capabilities up to 1/2 in. (1.3 cm) thickness
- Easy to use computer interface control panel
- 9 Programmable job locations
- LCD temperature displays for each heating surface
- Rear output cut-off blade

Applications:

- Encapsulation - Promotional materials, posters, counter cards, POP displays, calendars, instructional displays, phone/ debit cards, blueprints, menus, placemats, maps, flipcharts, etc.

Section 3.2 Consumables

Film types:

- Poly-in films, thermal and pressure sensitive
- Poly-out films, thermal and pressure sensitive

Film diameters:

- Up to a 7 in. outside roll diameter (18 cm)

Core Size:

- 2-1/4 in. adapters included (57 mm)
- 3 in. core standard (76 mm)

Film widths**Titan 165:**

- 61 in. Thermal films (155 cm)
- 62 in. Pressure sensitive films (157 cm)

Titan 110:

- 42 in. maximum paper width (107 cm)
- 42 in. Pressure sensitive films (107 cm)

Paper widths**Titan 165:**

- 62 in. maximum paper width (155 cm)

Titan 110:

- 42 in. maximum paper width (107 cm)

Section 3.3 Function

Speed:

- | | |
|---------------|---------------------------------|
| U.S. | • 0 - 10 fpm (0 - 3 m / min) |
| Europe | • 0 - 5 fpm (0 - 1.5 m / min) |

Motor:

- DC Gear motor

Heating capabilities:

- Up to 320 °F (160 °C)

Controls:

- Operations control panel

Roll design:

- High release silicone nip rollers
- High release silicone pull rollers

Section 3.4 Electrical

Requirements

- | | |
|--------------------------|--|
| Titan 165: | • 230 - 240 VAC, 60 Hz, single phase, 30 amps. |
| Titan 165 Europe: | • 230 - 240 VAC, 50 Hz, Single phase, 15 amps. |
| Titan 110: | • 230 - 240 VAC, 60 Hz, single phase, 20 amps. |
| Titan 110 Europe: | • 230 - 240 VAC, 50 Hz, Single phase, 15 amps. |

B.T.U. output

Titan 165:	U.S.	• 30708 B.T.U. / hour
	Europe	• 22519 B.T.U. / hour
Titan 110:		• 20472 B.T.U. / hour

Heater wattages

Titan 165:	U.S.	• 4500 W/ heater
	Europe	• 3300 W/ heater
Titan 110:		• 3000 W/ heater

Amperage draw

Titan 165:	U.S.	<ul style="list-style-type: none">• Drive motor = 3.3 amps• Fan motor = 0.5 amps• Motors and heaters = 25 amps
	Europe	<ul style="list-style-type: none">• Drive motor = 3.3 amps• Fan motor = 0.5 amps• Motors and heaters = 13 amps
Titan 110:		<ul style="list-style-type: none">• Drive motor = 3.3 amps• Fan motor = 0.5 amps• Motors and heaters = 12 amps

D/C Voltage used:	<ul style="list-style-type: none">• 36 vdc motor voltage• 24 vdc fan motor
--------------------------	---

A/C Voltage used:	• 230 vac (minimum)
--------------------------	-----------------------

Section 3.5 Dimensions

Weight

- Titan 165:**
- Machine only : 591 lbs. (268 kgs.) (Rev. B)
 - Shipping : 999 lbs. (453 kgs.) (Rev. B)
 - Gross weighth/ volume : 1201 lbs. (545 kgs.) (Rev. B)

- Titan 110:**
- Machine only : 463 lbs. (210 kgs.) (Rev. B)
 - Shipping : 756 lbs. (343 kgs.) (Rev. B)
 - Gross weighth/ volume : 941 lbs. (427 kgs.) (Rev. B)

Dimensions (W x L x H)

- Titan 165:**
- Machine: 77.25 in. x 25.5 in. x 49 in.
(196 cm x 57 cm x 124 cm)
 - Shipping: 87 in. x 39 in. x 59 in. (Rev. B)
(221 cm x 99 cm x 150 cm) (Rev. B)

- Titan 110:**
- Machine: 57.25 in. x 25.5 in. x 49 in.
(145 cm x 57 cm x 124 cm)
 - Shipping: 68 in. x 39 in. x 59 in. (Rev. B)
(173 cm x 99 cm x 150 cm) (Rev. B)

- Nip Height:**
- 35.50 in. (90 cm)

This page intentionally left blank.

Section 4 Installation

GBC Films Group is committed to a program of ongoing product improvement. As a result, we are providing these instructions so that you can insure that your new Titan 110/ 165 Laminator is properly and securely unpacked, moved, and installed.

Before a Titan 110/ 165 Laminator can be installed, there are a few requirements that must be met. Make certain that each of the requirements listed in the following pre-installation checklist are met before beginning installation.



CAUTION

Failure to follow the pre-installation check list can result in damage to the laminator.



Is the environment appropriate for the laminator? The laminator requires a clean, dust and vapor free environment to operate properly. It must not be located where there is air blowing directly on the machine.



Have you contacted a certified electrician to install a receptacle for the laminator and ensure that adequate power is being supplied, having the the appropriate capacity, over current protection and safety lockouts are available?



WARNING

The operating environment must be free of dust, flammable liquids and vapors. You can be injured by inhaling chemical vapors.

4.1 Pre-installation



Are the doorways and hallways wide enough for the the laminator to be moved to the installation site?



Is there ample room for the laminator?



A work area must be established that allows for unrestricted movement around the laminator and provides space for efficient material flow. Figure 4.1.4 and Figure 4.1.5 illustrates a typical machine area layout.



WARNING

Vapor build up or stored flammable liquids can cause a fire. Excessive dust can damage the laminator.



CAUTION

Do not locate the laminator where air is blowing directly on the machine. The air flow can cool the rollers unevenly and result in poor quality output.

U.S. and Canada: The laminator requires 220 to 240 vac, 60 hz, (Titan 165 - 30 amps) or (Titan 110 - 20 amps), single phase.

Europe: The laminator requires 220 to 240 vac, 50 hz, 20 amps (110 & 165), single phase

Figure 4.1.2 Connections - Titan 165 U.S.

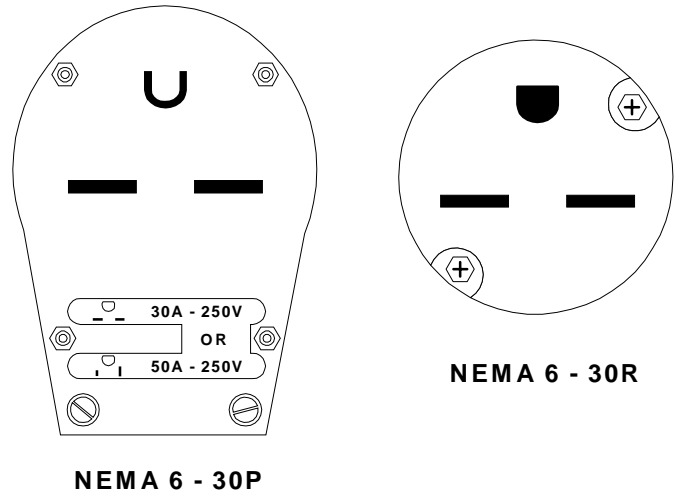

WARNING

The Titan 110/ 165 Laminator is a large and heavy piece of equipment. It is necessary to employ **LICENSED RIGGERS ONLY** to move the laminator. The laminator is not designed to be tipped up or sideways in any way. Such action disturbs the exact alignment of the rolling parts of the machine and requires extensive realignment. You can be crushed or seriously injured.

Figure 4.1.3 Connections - Titan 165 Europe

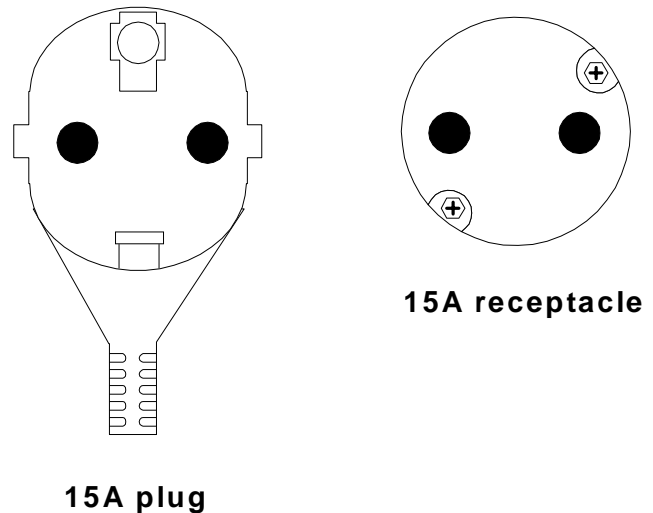

Figure 4.1.1 Connections - Titan 110

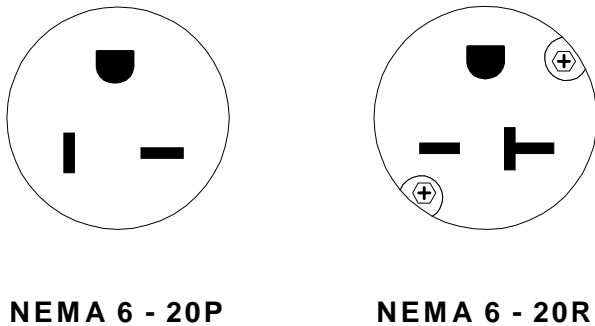

Figure 4.1.4 Suggested Floor Layout - Titan 110

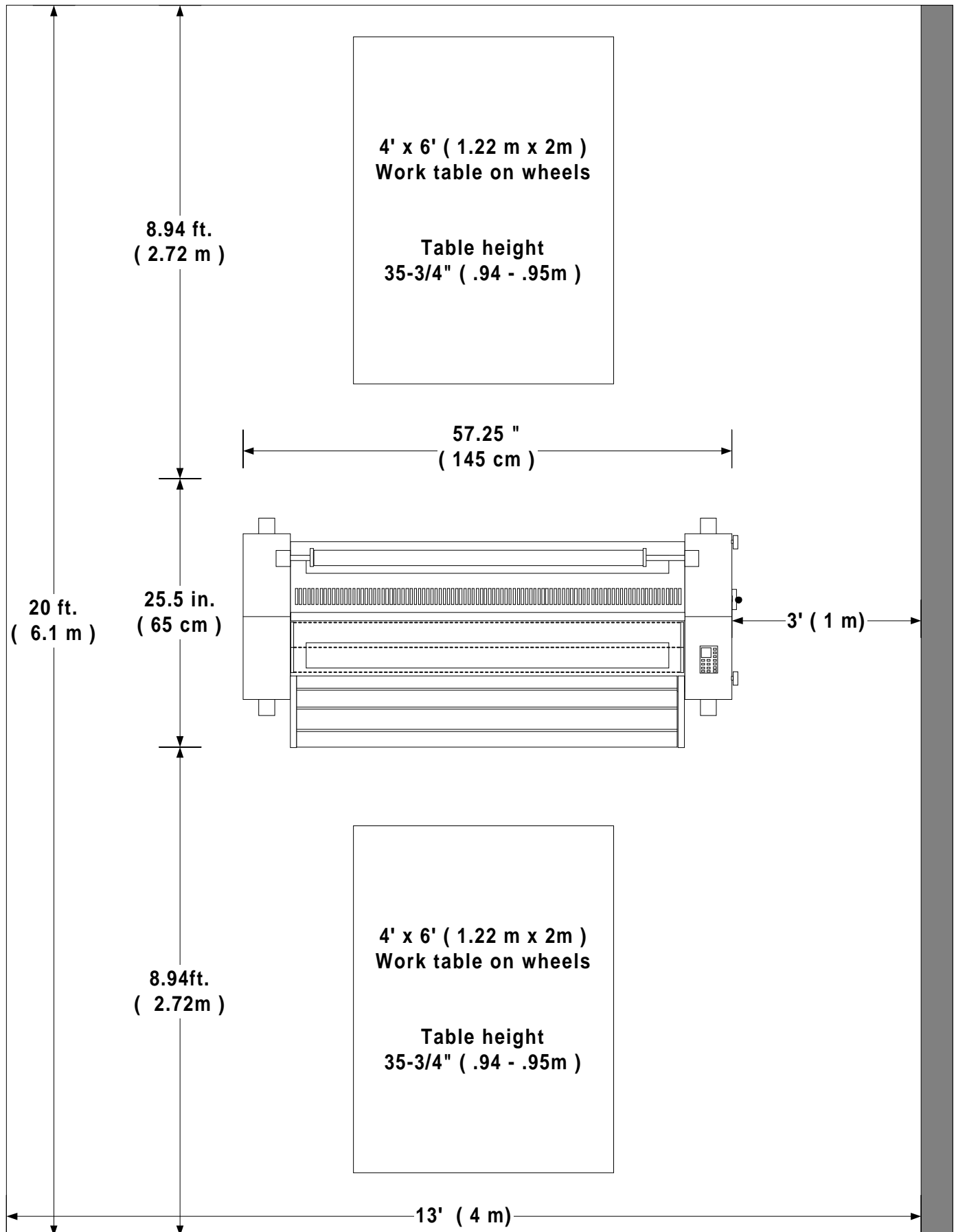
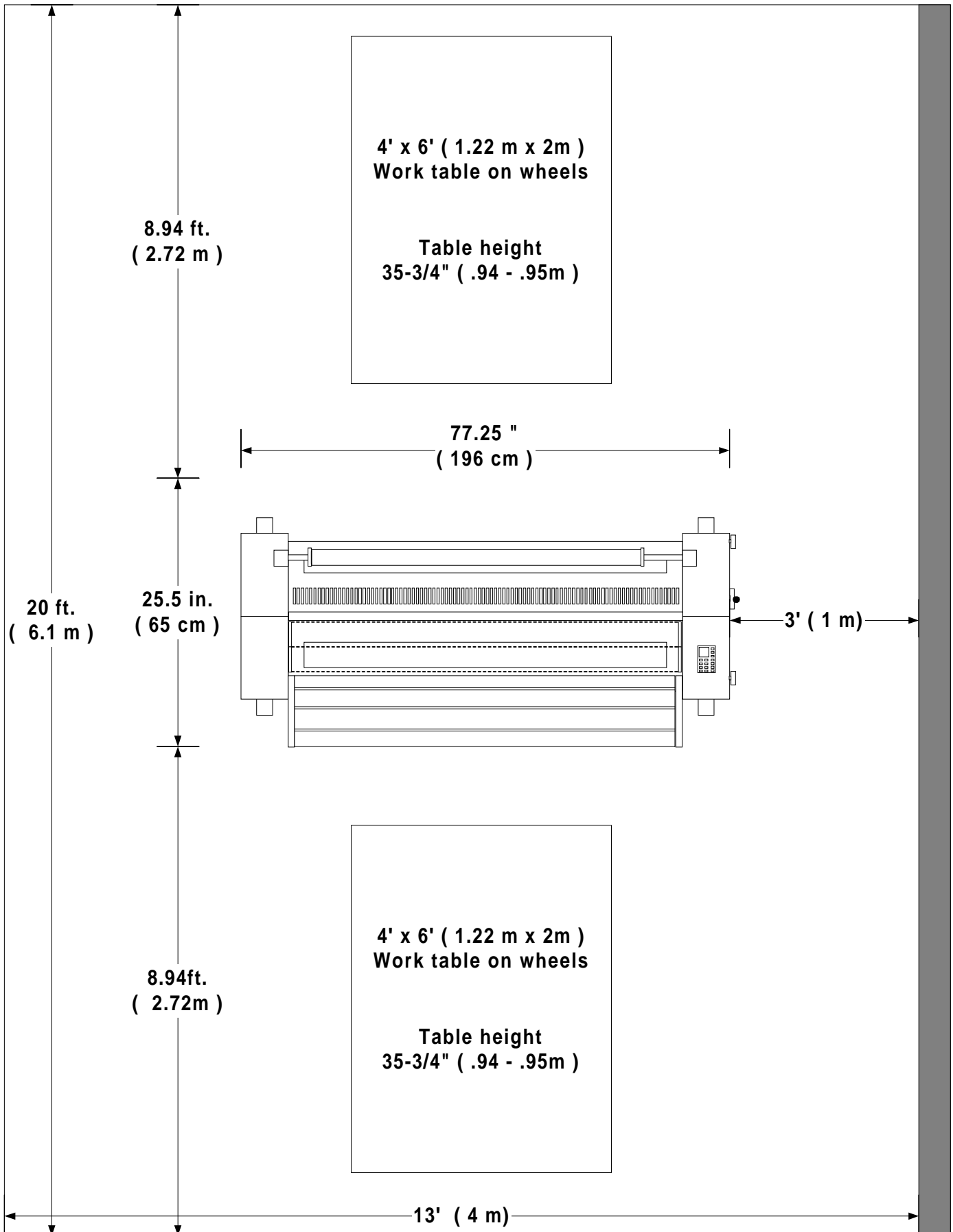

Figure 4.1.5 Suggested Floor Layout - Titan 165



4.2 Know your machine

Before performing any procedure within this manual, it is recommended that you take time to know the parts of your new machine.

Figure 4.2.1 Sides of the laminator

Front

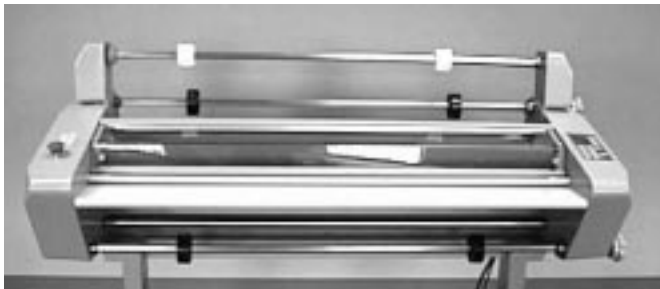

Rear

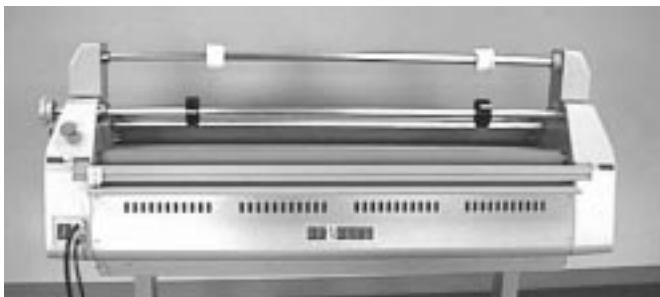

Right

Left



Figure 4.2.2 Safety

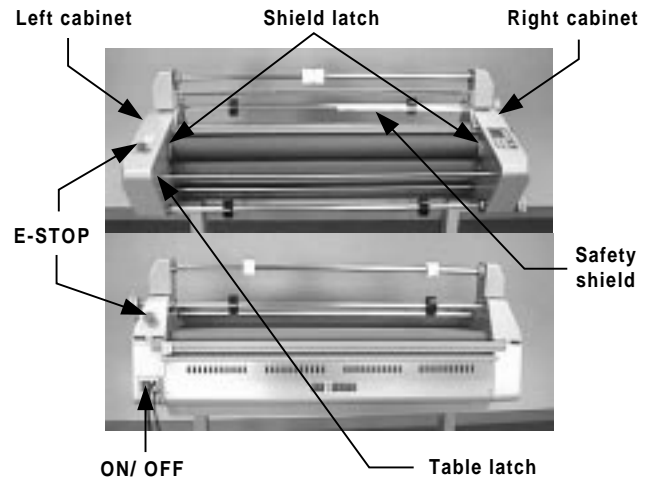

Figure 4.2.3 Rollers

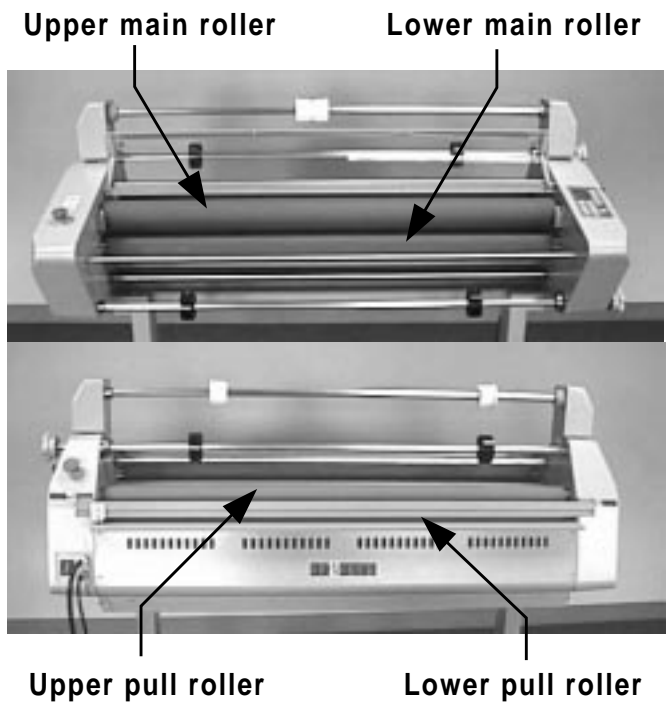

Figure 4.2.4 Idlers and shafts

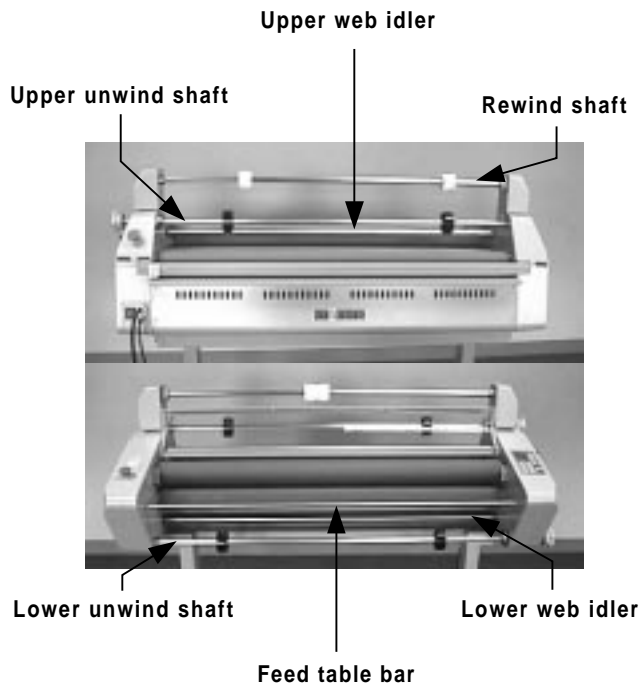

Figure 4.2.6 Right side

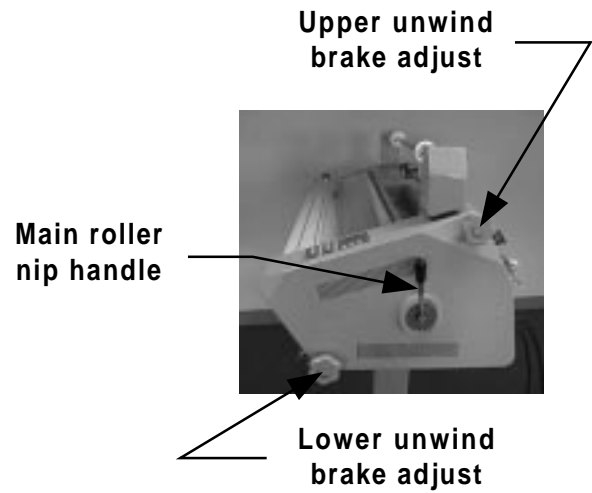

Figure 4.2.5 Hardware

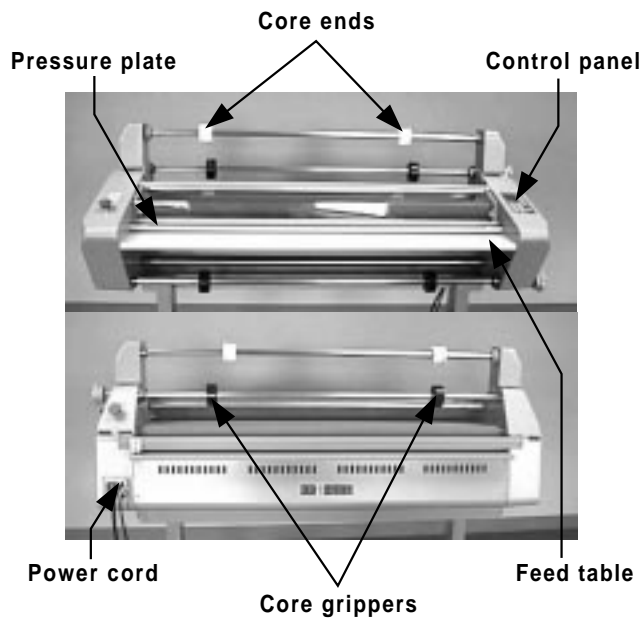
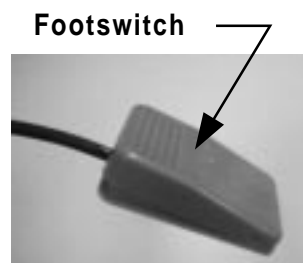
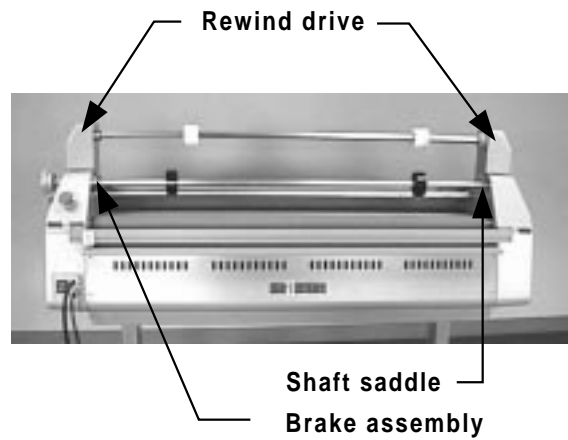

Figure 4.2.7 Miscellaneous



4.3 Unpacking



INFORMATION

ALL SHIPMENTS ARE EX-WORKS. At our dock, title passes to the buyer. Please review your insurance coverage prior to shipment, as you are responsible for all subsequent freight charges and risks.



INFORMATION

Before signing the Bill of Lading, you should be sure to inspect the crate and / or pallet for signs of damage or missing items; if applicable, make note of this on the Bill of Lading.



INFORMATION

Depending on the destination and customer preference, the Titan 110/ 165 may be shipped in various ways. The laminator may arrive shrink wrapped or in a plywood crate on a skid. Please follow the unpacking procedure that pertains to your method of shipment.

With regards to your shipping methods, use one of the following procedure described to safely and properly unwrap / uncrate your laminator.

4.4 Shrink Wrapped

a) Inspect the machine for any obvious shipping damages upon receipt.

b) Carefully unwrap the shrink wrap from around the laminator.



CAUTION

Do not use a knife or other sharp object to remove the shrink wrap from around the laminator. You can cause irreparable damage to the rollers.

c) With another person, carefully wheel your Titan 110/ 165 Laminator to the installation site.



WARNING

Do not attempt to move the laminator across anything other than a flat level surface without trained and qualified riggers. You can be crushed or seriously injured.

4.5 Crated



WARNING

The unpacking process requires at least two people. You can be severely injured, crushed or cause damage to the laminator.



INFORMATION

Do not put packing screws on the floor. They can cause problems when trying to roll the laminator into position or you can become injured if stepped on.

Tools required

- # 2 Phillips head screwdriver
- Large adjustable wrench
- Crow bar
- A second person



CAUTION

A second person must support the side labeled 5 in Figure 4.5.1 It can fall and damage the laminator or cause harm to you and others.

Figure 4.5.1 Disassembling of the crate

To uncrate the laminator

- a) Remove the top of the crate and then the sides in the order shown in **Figure 4.5.1**

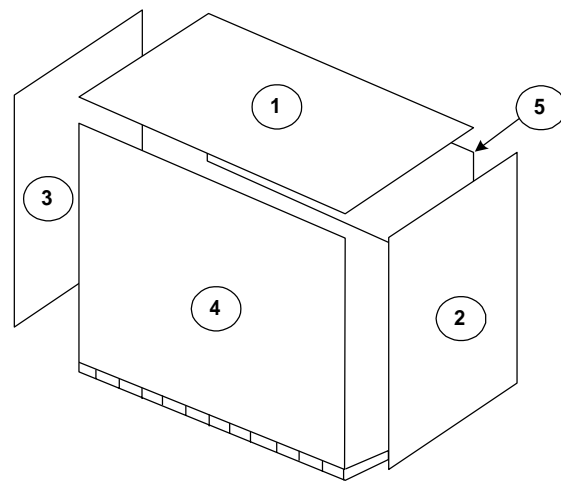

CAUTION

Do not allow the top to fall into the crate. It can damage the laminator.

Removing the shrink wrap

- a) Gently unwrap the shrink wrap from around the laminator.



CAUTION

Do not use a knife or other sharp object to remove the shrink wrap from around the laminator. You can cause irreparable damage to the rollers.



WARNING

The Titan 110/ 165 Laminator is a large and heavy piece of equipment. It is necessary to employ **LICENSED RIGGERS ONLY** to move the laminator. The laminator is not designed to be tipped up or sideways in any way. Such action disturbs the exact alignment of the rolling parts of the machine and requires extensive realignment. You can be crushed or seriously injured.



INFORMATION

GBC Films Group's warranty does not cover malfunction of the equipment due to mishandling and / or tipping. GBC Films Group bears no responsibility for personal injury or damage due to moving the laminator improperly.

Moving the laminator

- a) Have the laminator lifted off the skid and placed on the floor by licensed riggers.

- b) Remove any plastic strapping and/or packing paper taped to the machine.



WARNING

Do not attempt to move the laminator across anything other than a flat level surface without trained and qualified riggers. You can be crushed or seriously injured.



CAUTION

Do not use a knife or other sharp object to remove the shrink wrap from around the laminator. You can cause irreparable damage to the rollers.

c) Move all packing materials to a safe distance from the laminator and dispose of properly.

d) Use two people to carefully roll the laminator to the desired location.



INFORMATION

About recycling: The crate components can be reused for shipping the laminator again or can be disassembled and the wood and screws recycled. The shrink wrap is not recyclable, so it must be discarded.

e) Use **Figure 4.1.1** for the suggested floor layout and plug the laminator into the proper receptacle outlet.

4.6 Safety check

The safety check will ensure that all safety devices and interlock switches are functioning properly.



WARNING

Do not wear ties, loose fitting clothes or dangling jewelry while operating or servicing the laminator. These items can get caught in the nip and choke you or you can be crushed or burned.



WARNING

If a safety feature is not functioning properly, contact your local service representative immediately



DANGER

At no time should you attempt to over ride any of the safety latches on the laminator.

Feed table



INFORMATION

The laminator will operate only when all safety latches are in the fully latched position.

c) Press **RUN**.



a) Press **POWER** to “I”.

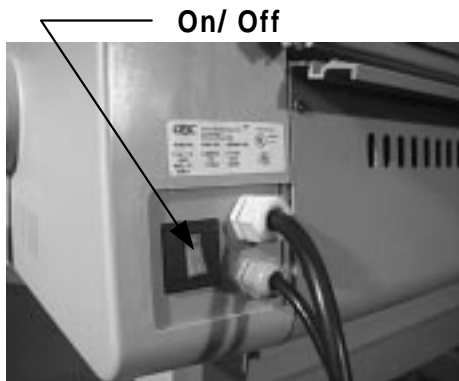

d) Under the left side of the feed table, slide the safety latch to the right. Bottom rollers stop.



c) Press **SPEED**  to “5”.



e) Release the safety latch, the bottom rollers revert to turning.



INFORMATION

Locator pins on the pressure plate are not associated with an interlock switch. The laminator can operate without the pressure plate installed.

Front safety shield



WARNING

Caution should always be exercised when using the laminator with the safety shields raised. You can be seriously HURT or INJURED!

- a) Raise the front safety shield. Bottom rollers stop.



- b) Lower the front safety shield to its fully closed position, the bottom rollers revert to turning.



INFORMATION

The laminator will operate only when all safety latches are in the fully latched position.

Emergency stops

- a) Press the front emergency stop (E-STOP) down. The bottom rollers stop turning.



- b) Rotate the E-STOP clockwise to reset. The bottom rollers revert to turning



- c) Repeat steps “a” and “b” for the rear E-STOP.

4.7 Control panel check

The control panel should be checked to ensure all controls function properly.

For a detailed explanation of the control panel and footswitch refer to **Section 5 Operations**.



INFORMATION

When any command is pressed on the control panel, an audible "beep" will be heard for each increment of change or each press.

a) Press **POWER** to "I".

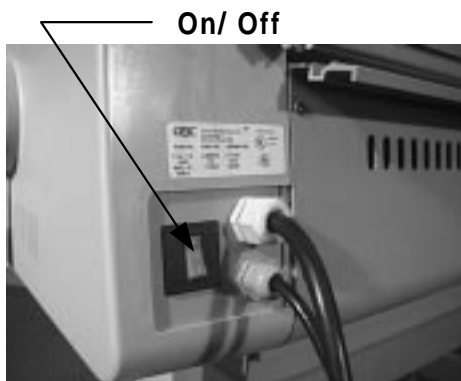

b) Press **STAND-BY**. The display indicates **AUTO-OFF** mode in the lower right corner.

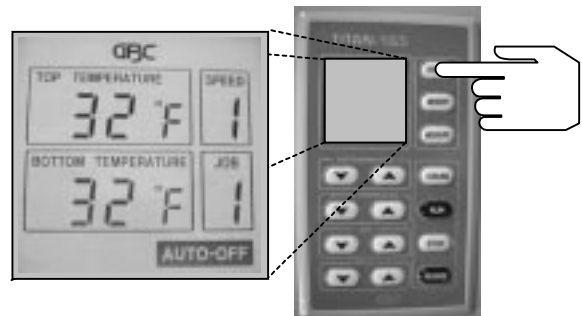

c) Press **STAND-BY** again. The display indicates **READY** mode in the lower left corner.

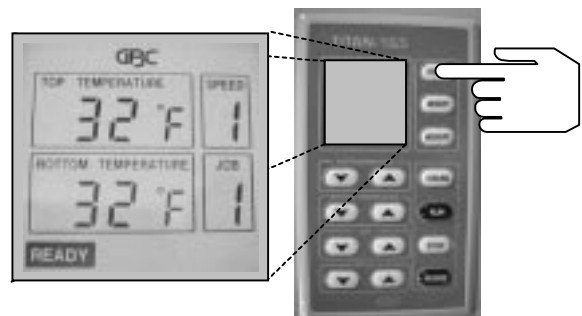

d) Press **MEMORY**. An audible beep is heard.

MEMORY is explained in **Section 5 Operations**



e) Press **COOLING**. The fans turn on.



h) Press **SPEED** . Numeric value for **SPEED** increases with a maximum setting of 9. The rollers increase in speed with each increment

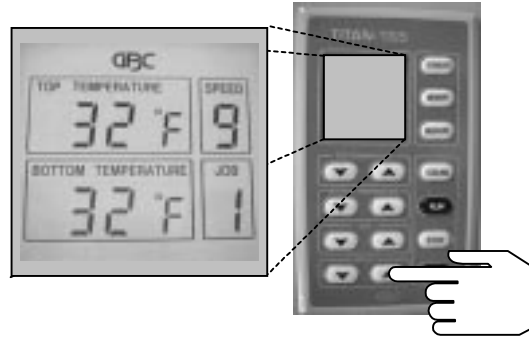

f) Press **COOLING** a second time. The fans turn off.



i) Press **SPEED** . Numeric value for **SPEED** decreases with a minimum setting of 1. The rollers decrease in speed with each increment

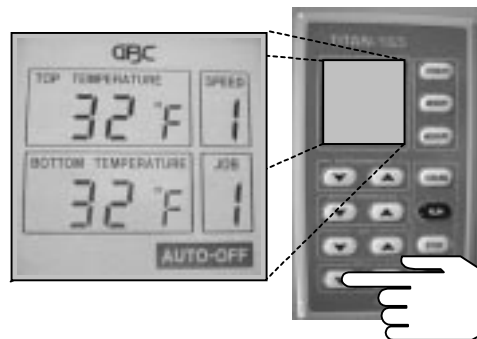

g) Press **RUN**. The bottom rollers begin turning towards the rear of the laminator.



j) Press **STOP**. The bottom rollers stop turning.



- k) Press **RUN** . The bottom rollers begin turning towards the front of the machine.



- n) Press **BOTTOM TEMPERATURE** (▲) .
Numeric value increases with a maximum setting of 320°F (160 °C).

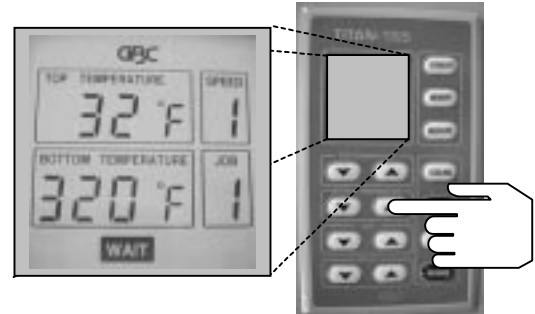

- l) Once confirmed, release. The bottom rollers stop turning in a reverse direction.



INFORMATION

Top and bottom set points are intentionally left at 320 °F (160 °C) for now.

- m) Press **TOP TEMPERATURE** (▲) .
Numeric value increases with a maximum setting of 320°F (160 °C).

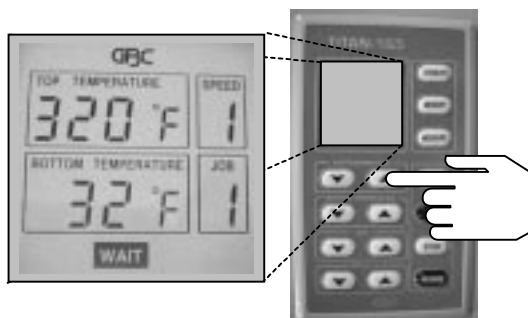

- o) Press **JOB** (▲) . Numeric value for **JOB** increases with a maximum setting of 9.

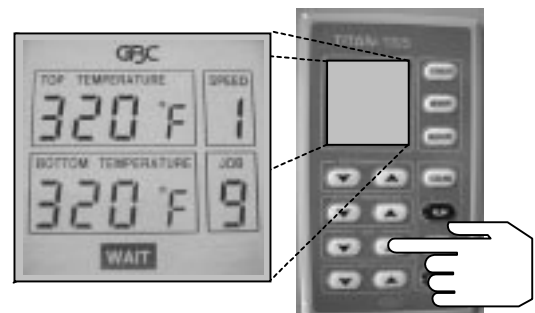

p) Press **JOB** . Numeric value for **JOB** decreases with a maximum setting of 1.

r) Lower the front safety shield to its fully closed position.

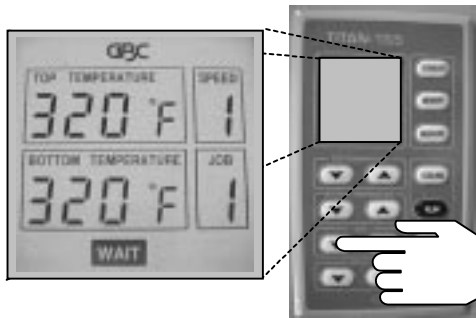



INFORMATION

The laminator will operate only when all safety latches are in the fully latched position.



WARNING

Caution should always be exercised when using the laminator with the safety shields raised. You can be seriously HURT or INJURED!

s) Press **TOP TEMPERATURE**  then **BOTTOM TEMPERATURE** . Numeric values decrease with a minimum setting of 32 °F (0 °C).

q) Raise the front safety shield and touch the upper and lower main rollers. They should feel warm to the touch.

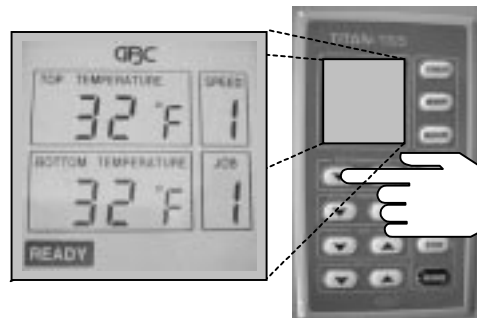

4.8 Roller handle

The roller handle raises and lowers the main rollers and the pull rollers simultaneously. The roller handle guide is notched with preset nip heights. The roller handle is located on the right side of the laminator.



CAUTION

Never leave the rollers in the down position without rolling. Prolonged contact in one area can form flat spots on the rollers.



WARNING

Keep hands and fingers clear of the laminator roller nip when changing GAP. You can be **CRUSHED** or **BURNED**!

- a) Pull the handle away from the notch and rotate toward the rear of the machine. The upper main roller and the upper pull roller lowers.

- b) Rotate the handle towards the front of the machine. The upper main roller and the upper pull roller raise up.

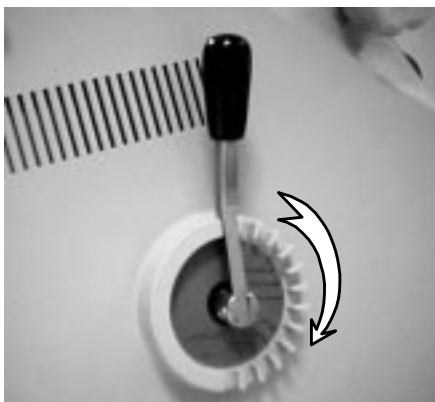
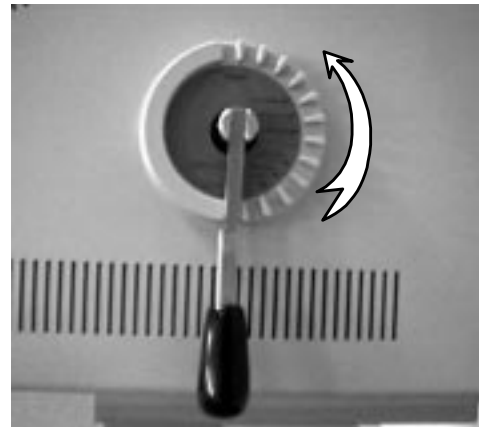

4.9 Film brake adjustment

Perform each of the following steps for the upper and lower unwind shafts while standing to the right of the front operating position.

Illustrations are for the upper unwind. The lower unwind is identical to the upper unwind with the exception of the saddle for the film brake adjustment assembly.



WARNING

Extreme caution should always be exercised working around the core gripper support, the gripper tabs can cut you!

- As you turn the film brake adjustment dial, you feel an increase in resistance while turning the unwind shaft.

- b) Rotate the unwind shaft while turning the film brake adjustment dial counter clockwise.

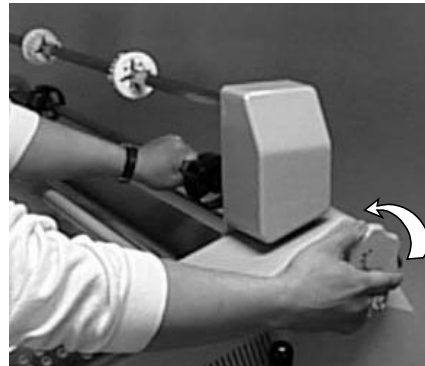

- As you turn the film brake adjustment dial, you feel a decrease in resistance while turning the unwind shaft.

- a) Use one hand to rotate the unwind shaft while the other hand is turning the film brake adjustment dial clockwise with the other hand.



- c) Perform the same steps for the lower unwind shaft and brake.



4.10 Rear cut-off blade



WARNING

Caution should always be exercised when using the rear cut-off blade. Sharp objects can cut you!



WARNING

Keep hands and fingers away from the path of the rear cut-off blade. Sharp objects can cut you!

- b) Release the rear cut-off blade tab. The blade retracts into the housing.



- c) Gently slide the rear cut-off blade from one side of the laminator to the other side. The movement should be smooth.

- a) Press down on the rear cut-off blade tab. The blade should extend from the housing smoothly.

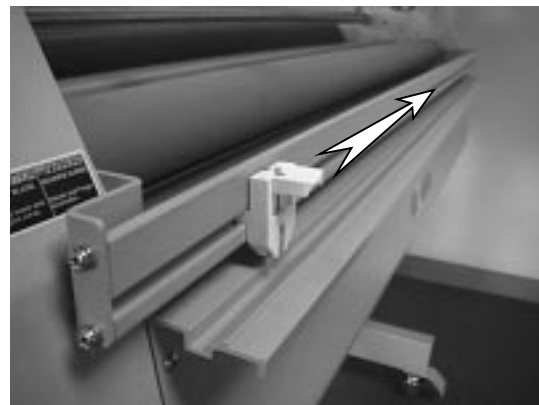

This page intentionally left blank.

Section 5 Operations

5.1 Control Panel



WARNING



Do not wear ties, loose fit clothing or dangling jewelry while operating or servicing the laminator. These items can get caught in the nip and choke you or you can be crushed or burned.

This section discusses the function of the control panel, how the footswitch operates, how to react to an emergency, remove and replace the safety shield, remove and replace the pressure plate, remove and replace the feed table, how to load film on the unwinds, how to center the film, how to change the nip, use the rear cut-off and job programming.

The operations of the **Titan 110** do not differ from the operations of the **Titan 165**. For illustration purposes, the Titan 110 is used.

The control panel on the Titan 110/ 165 Laminator is located at the front operating position of the machine on the right side cabinet.

The control panel enables the operator to control motor run/ stop, motor direction, motor speed, cooling fans, top temperature, bottom temperature, job number selection, job programming and temperature reading.

(1) **STAND-BY** : When pressed, sets the laminator in the **AUTO-OFF** mode (indicated in the lower right corner of the display). Pressing  again will set the laminator into **READY** mode. **AUTO-OFF** mode will automatically be set when no motor action occurs within a four (4) hour time span. After three (3) hours of no motor action, the laminator automatically drops the heater temperatures to 176 °F (80 °C).



INFORMATION

The laminator will operate only when all safety latches are in the fully latched position.

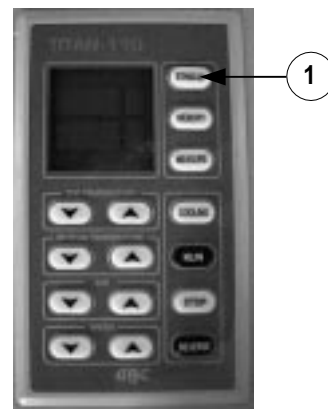

(2) **MEMORY** MEMORY: When pressed twice, stores the current parameter settings in the displayed job location.

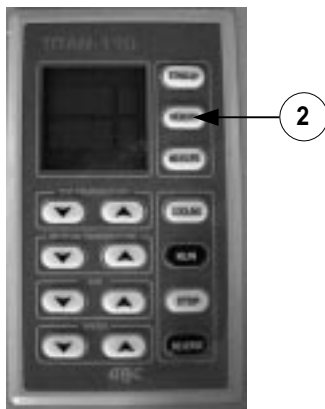

(4) **COOLING** COOLING: When pressed, turns the cooling fans on or off depending on the current state of the fans when pressed.

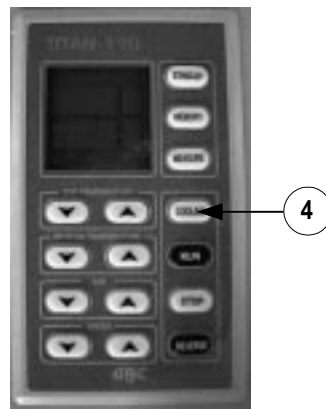

INFORMATION

Job programming is explained in Section 5.7



INFORMATION

If COOLING is illuminated, the cooling fans are in the "on" position.

(3) **MEASURE** MEASURE: When pressed, changes the display for the top temperature and bottom temperature from set point to actual roller temperature. The display will only show actual temperature while MEASURE is depressed.

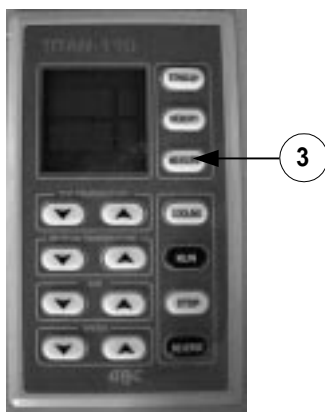

(5) **RUN** RUN: When pressed, supplies power to the motor and the rollers begin to turn in a forward direction at the current speed set in the display.

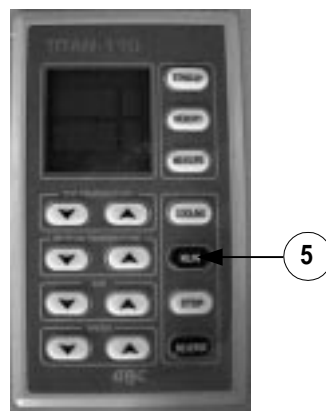

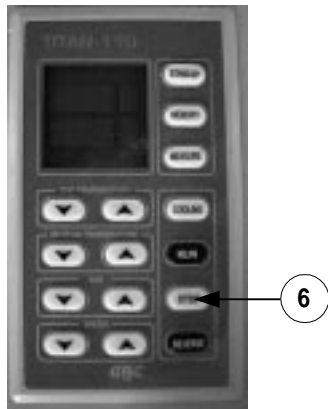

(6) **STOP**  : When pressed, removes power to the motor.

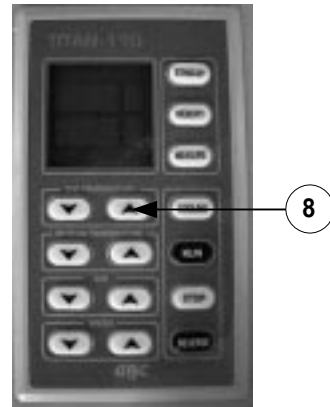

(8) **TOP TEMPERATURE**  : When pressed, increases the set point of the top roller temperature. Maximum input value is 320 °F (160 °C).



(7) **REVERSE**  : When pressed, supplies limited power to the motor and the rollers begin to turn in a reverse direction at a speed of 3.3 feet./ min. (1 meter/ min.) Reverse motion only occurs while  is pressed.

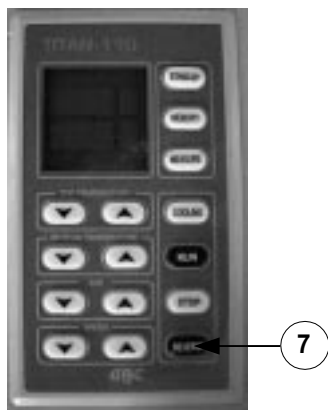

INFORMATION

When the set point value is higher than actual temperature, " WAIT " is indicated at the bottom of the display.



INFORMATION

Reverse speed is preset at 1 meter/ minute.

(9) **TOP TEMPERATURE**  : When pressed, increases the set point of the top roller temperature. Maximum input value is 32 °F (0 °C).

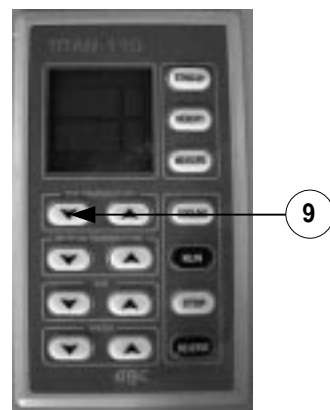

(10) **BOTTOM TEMPERATURE** : When pressed, increases the set point of the bottom roller temperature. Maximum input value is 320 °F (160 °C).

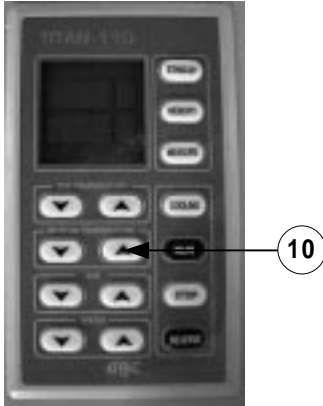

(12) **JOB** : When pressed, increases the job location number displayed. Maximum input value is 9.



INFORMATION

When the set point value is higher than actual temperature, " WAIT " is indicated at the bottom of the display.



INFORMATION

When the input value for JOB is changed, the parameters stored within that number are displayed.

(11) **BOTTOM TEMPERATURE** : When pressed, decreases the set point of the bottom roller temperature. Minimum input value is 32 °F (0 °C).

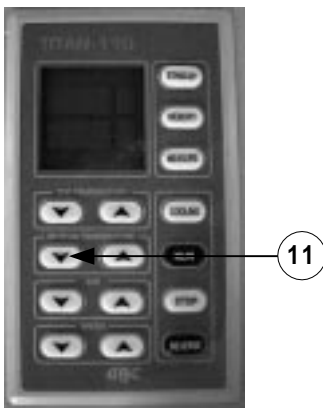

(13) **JOB** : When pressed, decreases the job location number displayed. Minimum input value is 1.



(14) **SPEED** (▲): When pressed, increases the speed number displayed. Maximum input value is 9.

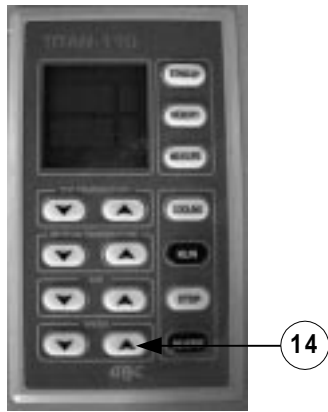

(16) **DISPLAY:** indicates what parameters are currently set at. Also indicates what mode the laminator is currently in.

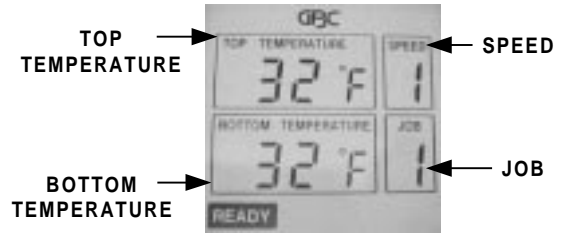

READY - Heaters are at operating temperature.



INFORMATION

When the input value for **JOB** is changed, the parameters stored within that number are displayed.



WAIT - Heaters are not at operating temperature

(15) **SPEED** (▼): When pressed, decreases the speed number displayed. Minimum input value is 1.



AUTO-OFF - Laminator is stand-by mode.



5.2 Reacting to an emergency

The Titan 110/ 165 Laminator has been designed with safety as a primary consideration; however, you must become thoroughly familiar with the controls, proper operation, proper service procedures, and safety features of the laminator before using or servicing the unit.

Use care in lowering the top laminating roller and know how to react quickly in an emergency. Before lowering the roller, ensure the nip area is clear.

One **E-STOP** is located on the left cabinet from the front operating position and the second is located above the main power ON/ OFF. Refer to **Figure 5.2.1**

Figure 5.2.1 E-STOPS

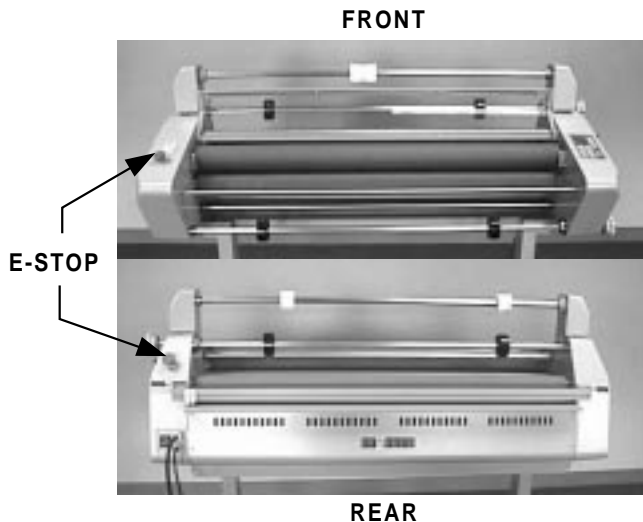

- a) In the event of an emergency, press an **E-STOP**.

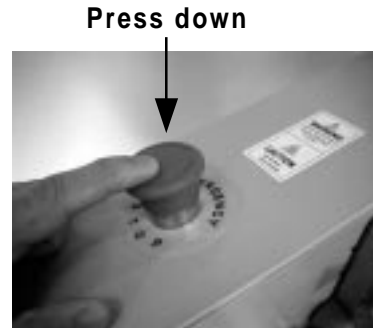

INFORMATION

When an **EMERGENCY STOP** is engaged, all motion stops. The nip will not change from the operating setting.

- b) Resolve the emergency situation.

- c) Press **STOP**.



INFORMATION

When the **E-STOP** is disengaged, the rollers will begin turning. By pressing stop first, The rollers will not turn until **RUN** is pressed

- d) Reset the **E-STOP** by rotating 1/4 turn clockwise. The **E-STOP** will unlatch.

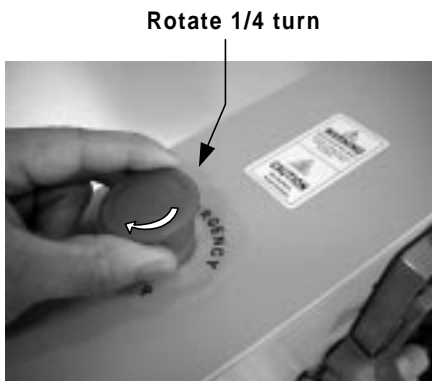
**INFORMATION**

The Temperature control panel settings are not affected when an E-STOP has been pushed.

- e) Ensure that the front safety shield is located in the fully closed position.

**INFORMATION**

Power to the motor is removed when the safety shield is not in the fully locked position.

5.3 Safety shield

**WARNING**

Caution should always be exercised when using the laminator with the safety shields removed. You can be seriously **HURT** or **INJURED**!

**DANGER**

At no time should you attempt to over ride any of the safety latches on the laminator.

**INFORMATION**

All **E-STOPS** must be unlatched, safety shield fully closed and feed table properly installed before operating.

The only time the safety shield should be removed is when you are webbing the laminator. At no time should you operate your laminator with the safety shield removed.

To remove the shield

To replace the shield

a) Raise the safety shield.



a) Position the safety shield tab on the left with the shield positioning hole on the laminator.



b) Pull on the locator pin on the right from the front operating position.



b) Pull on the locator pin on the right from the front operating position.



c) Lift the table up and out toward the right side of the laminator.



c) Lower the safety shield to its fully closed position.



5.4 Pressure plate



INFORMATION

Locator pins on the pressure plate are not associated with an interlock switch. The laminator can operate without the pressure plate installed.

The pressure plate assists in keeping the leading edge and the trailing edge of the print flat when fed into the laminator. The pressure plate may be installed or removed depending on operator preference.

To remove the pressure plate



WARNING

Caution should always be exercised when using the laminator with the safety shields raised. You can be seriously HURT or INJURED!

a) Raise the safety shield.



b) Pull on the locator pins on the right and left sides of the pressure plate and lift out

Locator pin



To replace the pressure plate

a) Pull on the locator pins on the right and left sides of the pressure plate and position with the pressure plate locator holes on the laminator.

Locator pin



b) Lower the safety shield to its fully closed position.



5.5 Feed table

To remove the feed table

The feed table is designed to be removable allowing for quick and easy film webbing. The laminator will only operate with the feed table in proper position.

- a) Raise the safety shield and remove the pressure plate.



WARNING

Caution should always be exercised when using the laminator with the safety shields removed. You can be seriously HURT or INJURED!



DANGER

At no time should you attempt to over ride any of the safety latches on the laminator.

- b) Pull the feed table safety pin located on the left side from the front operating position.



INFORMATION

All E-STOPS must be unlatched, safety shield fully closed and feed table properly installed before operating.

- c) Lift the rear of the feed table up and pull the feed table out away from the laminator.

To replace the feed table

- a) Align the front of the feed table with the front feed table support pegs.

Front feed table
support peg

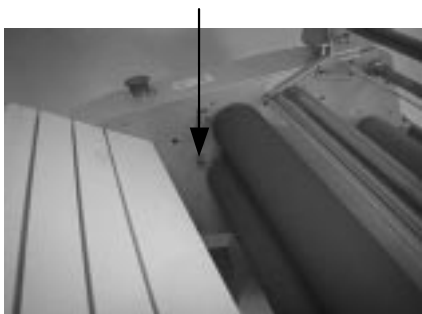

- b) Pull the feed table safety pin. Set the rear of the table down on the rear table support bar.



Rear feed table support bar

- c) Replace the pressure plate if needed and lower the safety shield to its fully closed position.

5.6 Film loading

The Titan 110/ 165 can accommodate Poly-In or Poly-Out films. Each film requires a different loading procedure. Refer to **Section 6 Applications** for webbing methods. With regards to webbing methods, both require the adhesive side of the film to face away from the heating components.



WARNING

Extreme caution should always be exercised when removing an unwind shaft, the gripper tabs can cut you!

Upper unwind

- a) Lift the upper unwind shaft up from the shaft saddle.



- b) Pull the upper unwind shaft out from the upper unwind shaft support.



- d) Ensure the gripper teeth are facing the proper direction for Poly-in or Poly-out film. Use the correct combination to suit your film



(1) Upper Poly - in

(2) Lower Poly - out



(2) Upper Poly - out

(1) Lower Poly - in



WARNING

Extreme caution should always be exercised working around the 3 inch core grippers, the gripper tabs can cut you!

- c) If using the 2 1/4 in. (5.7 cm) core adapters, go to step “ g ”. If using the 3 in. (7.6 cm) core grippers proceed with the next step.

- e) Use a 4 mm allen wrench to secure the core gripper to the shaft so the grippers fall close to the end of the roll of film.



2 1/4 inch (5.7 cm) adapters



3 inch (7.6 cm) grippers

- f) Slide the unwind shaft into the roll of laminate. Proceed with step “ i ”.

- g) If using the 2 1/4 in. (5.7 cm) adapters, insert one adapter into one end of the roll of film.



- j) Set the rounded end of the unwind shaft into the upper unwind saddle.



- h) Slide the unwind shaft into the roll of film then the other core adapter.



- k) Repeat steps “ a ” through “ j ” for the lower unwind shaft.



CAUTION

Ensure the roll of laminate is loaded properly on the unwind shaft.
Exposed adhesive should be facing away from the heated components.
This will prevent hours of cleaning!

- i) Insert the brake assembly side of the unwind shaft in first. (Core grippers are used for illustration purpose only)



INFORMATION

For core grippers, turning the roll film in the same direction as the gripper tabs while sliding makes loading the film onto the unwind shaft easier.

5.7 Film alignment

When using two rolls of laminate, the two rolls should be closely aligned to one another. This prevents exposed adhesive from contacting the rollers.

- a) Make the necessary adjustments to the upper roll of laminate to center it to the main rollers.



- b) Remove the safety shield by raising the shield and pulling the positioning pin out located on the right side from the front.



- c) Remove the front feed table by pulling the safety pin located under the feed table on the left from the front.



- d) Pull the laminate from the upper unwind down to the lower roll of laminate.



- e) Make the necessary adjustments to the lower roll of laminate to match up with the upper roll of laminate.

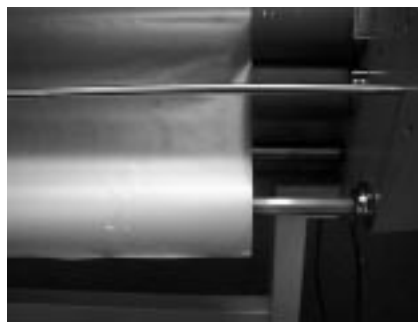

5.8 Change the nip

The roller handle raises and lowers the main rollers and the pull rollers simultaneously. The roller handle guide is notched with preset nip heights. The roller handle is located on the right side of the laminator.



WARNING

Keep hands and fingers clear of the laminator roller nip when changing GAP.
You can be **CRUSHED** or **BURNED**!



CAUTION

Never leave the rollers in the down position without rolling. Prolonged contact in one area can form flat spots on the rollers.



Handle in the raised position.



Pull handle away from the notch.



Lower handle to desired position.



Push handle into the notch

a) To change the nip opening, pull the handle away from the notch and move to the desired setting and secure the handle in the appropriate notch.

b) To raise the rollers, follow the steps above in reverse order.

5.9 Rear cut-off blade

- a) Slide the rear cut-off blade about six inches into the web.



WARNING

Caution should always be exercised when using the rear cut-off blade. Sharp blade can cut you!



The rear cut-off blade is intended to cut the web output from the laminator and should not be used for any other purposes.



WARNING

Keep hands and fingers away from the bottom of the rear cut-off blade. Sharp blade can cut you!



CAUTION

Stop the laminator before using the rear cut-off blade. Moving material can damage the rear cut-off blade!

- b) Press and hold down the blade engage lever.



WARNING



Keep hands and fingers away from the path of the rear cut-off blade. Sharp blade can cut you!





- c) Slide the rear cut-off blade from one side to the opposite side then release.

5.10 Job programming

Job programming enables the operator to store operating parameters for various frequent applications. 9 preset speed and temperature settings may be programmed.

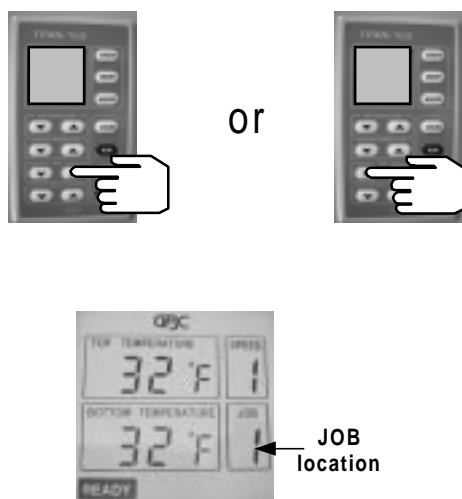

- a) Press JOB  or  to select the desired job number location. The selected location is displayed.

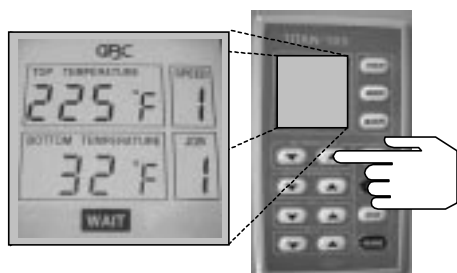

- b) Enter the desired temperature for the upper main roller by pressing top temperature  or .



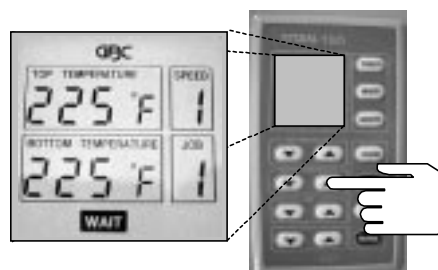

- c) Enter the desired temperature for the lower main roller by pressing bottom temperature

 or .



- d) Enter the desired speed by pressing speed

 or .

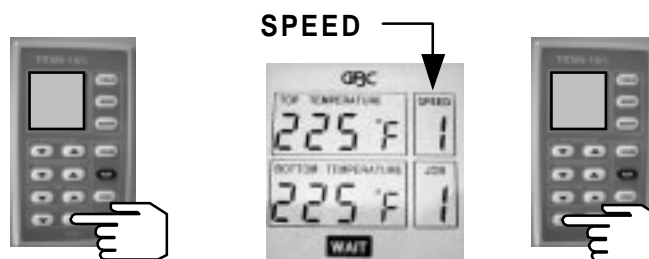

- e) Press  twice. The parameters are now stored in the selected job location.



This page intentionally left blank.

Section 6 Applications

6.1 Pressure Sensitive

The Titan 110/ 165 can accommodate Poly-in or Poly-out films. Poly-out means the adhesive is on the outside of the roll. Each film requires a slightly different loading procedure. Refer to Web diagrams at the end of this section.

The shiny side of clear film must contact the heating components with the dull sides (adhesive side) facing out. Use caution when loading matte or delustered film since both sides appear dull.

The top and bottom rolls of laminating film must be of the same width and be present simultaneously.

Follow the procedure below to web the Titan 110/ 165 for pressure sensitive laminate and pressure sensitive mount adhesive.

Materials need

- 1 roll of pressure sensitive laminate
(Same width as mount adhesive)
- 1 roll of pressure sensitive mount adhesive
(Same width as roll of laminate)
- Enclosed blade
(i.e. Zippy™ knife)
- Leader board
(approximately 24 in. in length (61 cm))
- Images
(i.e. Inkjet, piezo, electrostatic, offset)



WARNING

Do not wear ties, loose fit clothing or dangling jewelry while operating or servicing the laminator. These items can get caught in the nip and choke you or you can be crushed or burned.



INFORMATION

The Titan 110 is used for illustration purposes. The procedure is the same for the Titan 165.



CAUTION

Ensure the roll of laminate is loaded properly on the unwind shaft. Exposed adhesive should be facing away from the heated components. This will prevent hours of cleaning!

The procedures and parameters described in this section are reference points only. Parameters will vary with regards to laminate thickness, laminate widths, laminate types, print types, ink or toner types, environment conditions and operator experience.

- a) Press power to “ ON ”.



WARNING

Caution should always be exercised when using the laminator with the safety shields removed. You can be seriously HURT or INJURED!

- b) Place the roll of pressure sensitive laminate on the upper unwind shaft and center on the main rollers.



- d) Remove the feed table and position the roll of pressure sensitive mount adhesive onto the lower unwind shaft.



- c) Remove the safety shield and set aside for now.



- e) Bring the mount adhesive up to the roll of laminate and adjust to match and secure the upper and lower rolls in place. Rewind the mount adhesive.



f) Guide the upper laminate under the upper idler and separate the release liner from the laminate.



i) Grip the web and the upper main roll while turning towards the nip opening.



g) Tape the release liner to the rewind tube and allow the laminate to hang over the main rollers.



j) Manually turn the rewind tube to roll the release liner back to the upper idler.



h) Pull the mount adhesive up to the nip and tack it to the laminate hanging over the rollers.



k) Replace the feed table.



l) Replace the safety shield.



n) Enter a comfortable working speed on the control panel.

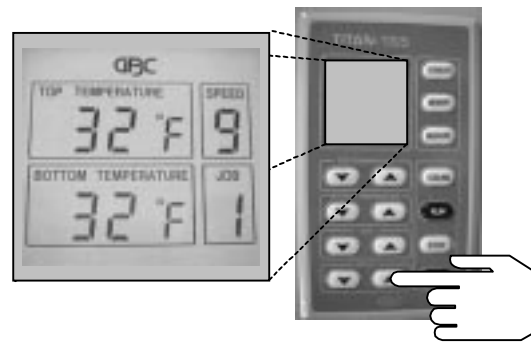

WARNING

Keep hands and fingers clear of the laminator roller nip when changing GAP. You can be CRUSHED or BURNED!

o) Press **RUN** on the control panel.



m) Lower the rollers.



p) Feed the images into the laminator.



INFORMATION

Speed can be increased during operation.

- q) After the last image has cleared the rear cut-off blade, trim the web from the laminator.



6.2 Mounting

Follow the procedure below to use the Titan 110/ 165 for pressure sensitive mounting.

Materials need

- r) Raise the rollers.

- Images with laminate and mount adhesive
(typical decal)
- Substrate
(compatible with the mount adhesive used)



INFORMATION

The Titan 110 is used for illustration purposes. The procedure is the same for the Titan 165.

- s) Remove the web from the laminator and clean any adhesive that may have contacted the rollers.

- a) Press power to “ ON ”.



- b) Carefully pull back approximately 1 in. (2.5 cm) of the release liner from the back of the image



- c) Align the edge of the image you just peeled the release liner from with the leading edge of the substrate and tack down.



 **WARNING**

Caution should always be exercised when using the laminator with the safety shield removed. You can be seriously HURT or INJURED!

- d) Remove the safety shield.



- e) Position the leading edge (the tacked image edge) of the substrate into the main roller nip and lower the roller.



INFORMATION

Avoid tacking at the ends first and pressing towards the center, you may create a tunnel once you have reached the center. This will make for a difficult mounting application.

- f) Lower the rollers to the appropriate position with regards to the thickness of the substrate being used.

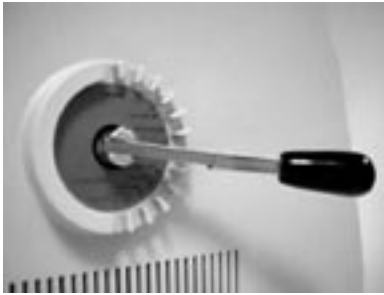

- i) Release the footswitch once the board has passed through the pull rollers.



- g) Position one hand on the image against the upper main roller and the use the other hand to grip the release liner.



- i) Raise the rollers.



- h) Press on the footswitch and pull the release liner as the board enters the main roller nip. Do not let go of the image until the edge reaches the center of the upper roller.



CAUTION

Do not use the rear cut-off blade to trim the substrate! You can damage the blade.

6.3 Encapsulation

Follow the procedure below to web the Titan 110/ 165 for thermal encapsulation.

Materials need

- 2 rolls of thermal laminate
(both must be of same width)
- Enclosed blade
(i.e. Zippy™ knife)
- Leader board
(approximately 24 in. in length (61 cm))
- Images
(i.e. Inkjet, piezo, electrostatic, offset)



INFORMATION

The Titan 110 is used for illustration purposes. The procedure is the same for the Titan 165.



CAUTION

Ensure the roll of laminate is loaded properly on the unwind shaft.
Exposed adhesive should be facing away from the heated components.
This will prevent hours of cleaning!

- a) Press power to “ ON ”.



- b) Set **TOP TEMPERATURE** to 225°F (107 °C).

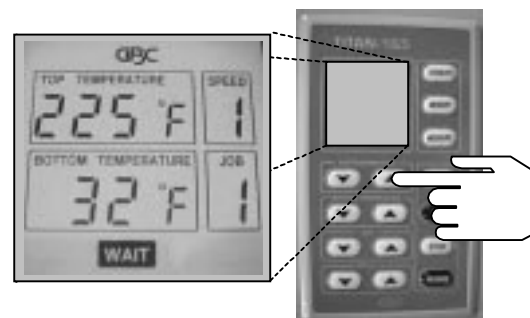

- c) Set **BOTTOM TEMPERATURE** to 225°F (107 °C).

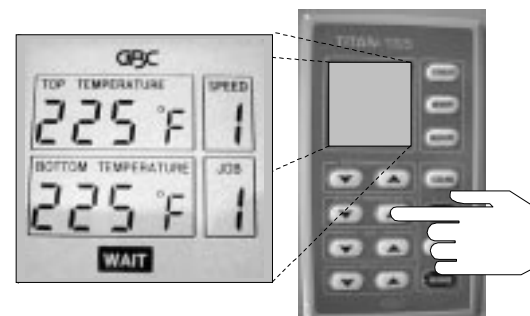

**INFORMATION**

The temperature may differ with regards to your laminate. The temperature used is for instructional purposes only.

**CAUTION**

Ensure the roll of laminate is loaded properly on the unwind shaft. Exposed adhesive should be facing away from the heated components. This will prevent hours of cleaning!

**WARNING**

Caution should always be exercised when using the laminator with the safety shield removed. You can be seriously HURT or INJURED!

- f) Place one roll of film on the upper unwind and center it to the main rollers.

- d) Remove the safety shield.



- g) Place one roll of film on the lower unwind shaft.

- e) Remove the feed table



h) Pull the laminate from the lower unwind up to the film on the upper unwind and adjust the lower to match the upper. Secure both rolls in place.



j) Pull enough of the upper laminate so that it rests on both the upper and lower main rollers. Continue when the READY indicator is illuminated on the display.



i) Pull the laminate from the upper unwind over the upper idler and place on top of the rollers.



k) Guide the laminate from the lower unwind around the back side of the lower idler.



WARNING

Keep hands and fingers away from the heat rollers.
You may be BURNED!

l) Tack the lower film to the upper film resting on the main rollers.



o) Replace the safety shield.



m) Push the leader board into the main roller nip.



p) Lower the rollers enough to move the board through the pull rollers.



n) Replace the feed table.



q) Enter a comfortable working speed on the control panel.



r) Press **RUN** on the control panel.



u) Set the roller nip handle to the appropriate positioning for the film being used.



s) Press **STOP** when the leader board has completely passed through the pull rollers.



v) Press **RUN** on the control panel.



t) Use the rear cut-off blade to separate the leader board from the web.



w) Feed the images into the laminator.



- x) After the last image has cleared the rear cut-off blade, trim the web from the laminator.



Figure 6.1.1 Poly-in / Poly-out

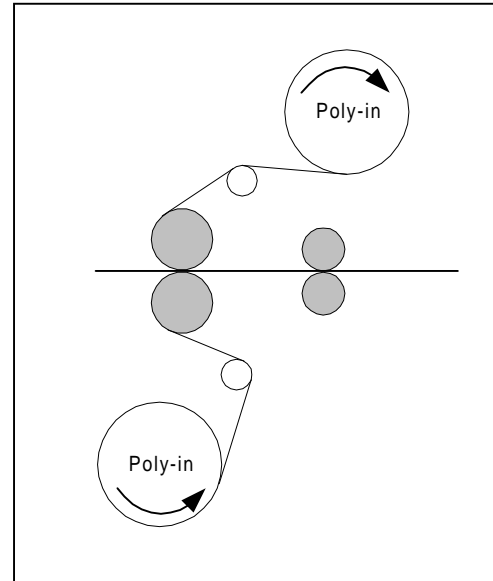

- y) Raise the rollers.

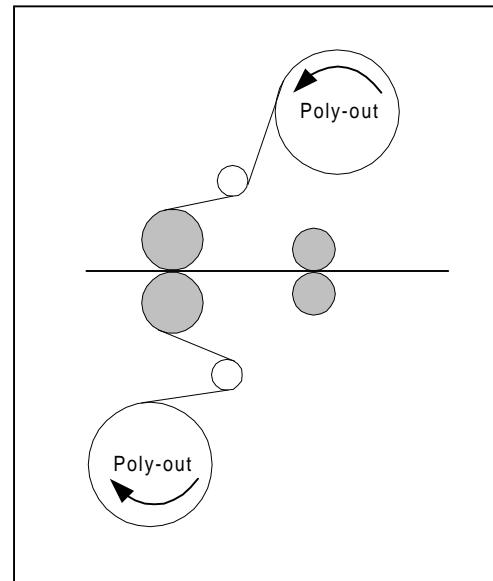

- z) Remove the web from the laminator and clean any adhesive that may have contacted the rollers.



INFORMATION

Use the appropriate diagram for the type of film you are using.

This page intentionally left blank.

Section 7 Troubleshooting



WARNING

Do not wear ties, loose fitting clothes or dangling jewelry while operating or servicing the laminator. These items can get caught in the nip and choke you or you can be crushed or burned.

As an operator, you can perform simple troubleshooting to correct typical output problems. Use the following guide for assistance.

7.1 Wave problems

Following is a list of common output wave problems you may encounter.

The arrow along the length of the web represents the direction of (travel).



INFORMATION

For optimal temperature settings of various laminates, contact your supplier or sales representative.

Problem: D waves in the image but not in the laminate

Cause: Excessive roller pressure.

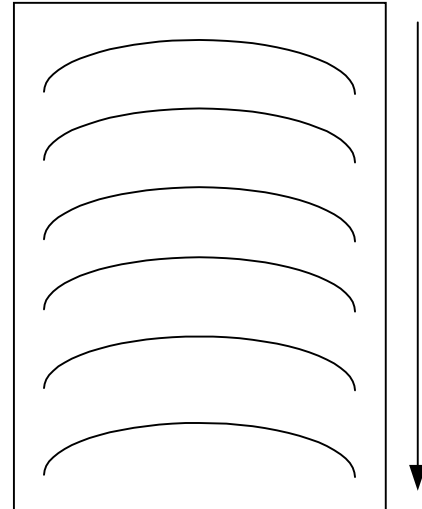

Hints:

- Check paper tension
- Check relative moisture content of the paper

Problem: D Waves in the laminate

Cause: Insufficient roller pressure.

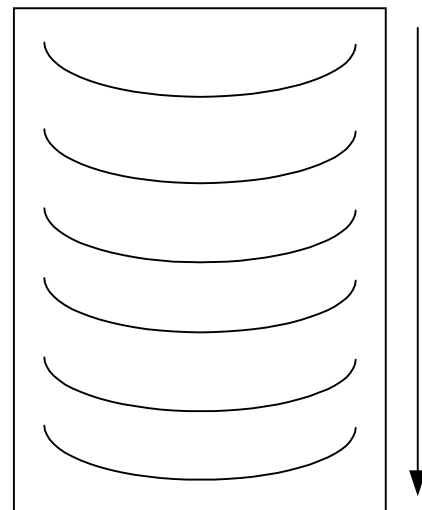

- Hints:**
- Check the roll pressure
 - Check the main roll nip settings
 - Check the pull roll nip settings
-

Problem: Straight waves in the output

Cause: Excessive heat at the nip rollers

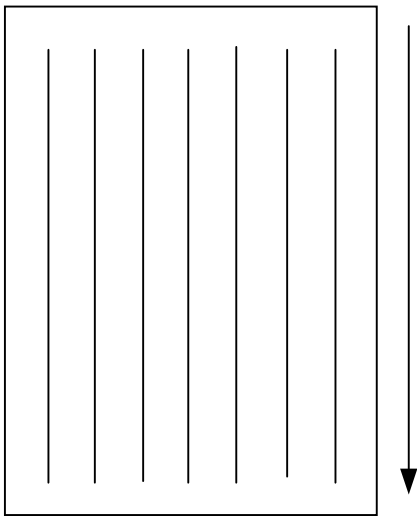

- Hints:**
- Check operational settings for materials being used.
-

Problem: Waves on only one side of the output

Cause: Insufficient roller pressure on one side.

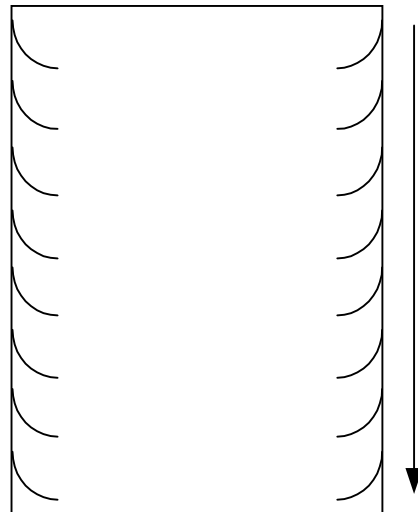

- Hints:**
- Check for insufficient main roller pressure
 - Check for insufficient pull roller pressure
 - Check the main roller nip settings
 - Check the pull roller nip settings

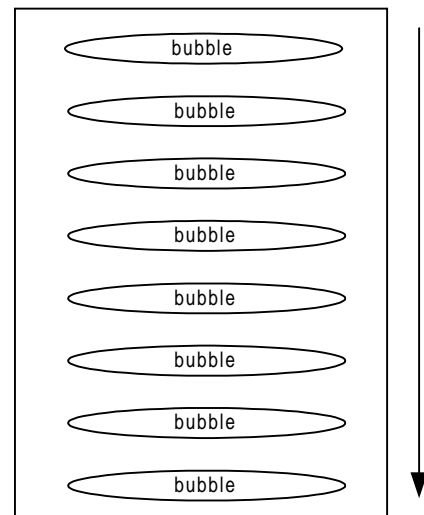

Problem: Indent waves in output after the pull rollers

Cause: Handling the web before it has a chance to cool.

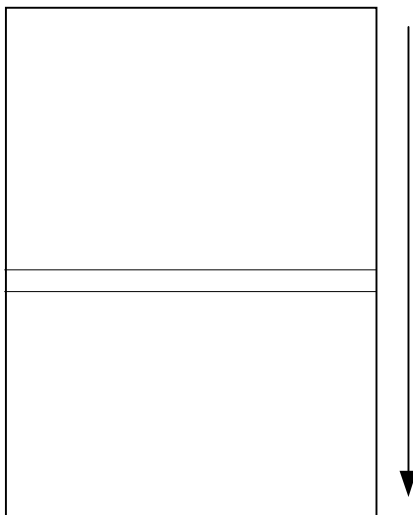

- Hints:**
- Check for consistent distance between bubbles.
 - Verify that bubbles are present with and without paper in the web.

Problem: Sparatic bubbles in the web

Cause: Excessive moisture

- Hints:**
- Insufficient cooling time
 - Allow output to cool before handling
 - Check operating temperatures of material

Problem: Evenly spaced bubbles in the web.

Cause: Bowed rollers

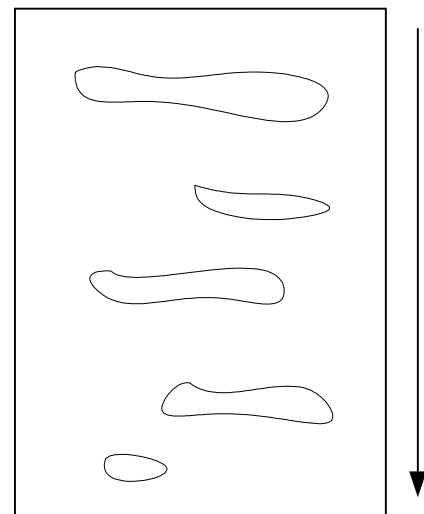

Hints: Store prints in a dry place.

7.2 Troubleshooting chart

Symptom	Possible cause	Possible cause
Motor is not working	<ul style="list-style-type: none"> • E-STOP is pressed • Feed table not installed correctly • Safety shield is raised 	<ul style="list-style-type: none"> • Unlatch E-STOP • Reinstall feed table • Close the safety shield
Roller has no heat	<ul style="list-style-type: none"> • Job parameter is set for no heat 	<ul style="list-style-type: none"> • Select new job number or increase set point
Waves in output	<ul style="list-style-type: none"> • Cooling fans are off • Film tension is incorrect • Insufficient roller pressure • incorrect speed 	<ul style="list-style-type: none"> • Turn cooling fans on • Adjust film tension • Adjust roller pressure • Adjust speed
Output looks cloudy	<ul style="list-style-type: none"> • Temperature is too low • Insufficient roller pressure 	<ul style="list-style-type: none"> • Increase temperature • Adjust roller pressure

Section 8 Maintenance

8.1 Maintenance Schedule

GBC Films Group laminators require minimal maintenance. However, regular maintenance is essential to keep any piece of precision machinery at peak performance. A maintenance schedule and a section of procedures are included in this section.



INFORMATION

Below is a recommended maintenance schedule. Before performing any of the steps listed, read through the procedures first. Please follow the instructions pertaining to the step you are performing.



WARNING

Do not wear ties, loose fitting clothes or dangling jewelry while operating or servicing the laminator. These items can get caught in the nip and choke you or you can be crushed or burned.



INFORMATION

Improper maintenance, can result in poor output quality.

GBC offers Cleaning kits (P/N 1711515) as well as Extended Maintenance Agreements.

The only maintenance required by the operator is to maintain clean and adhesive free nip rollers and overall cleanliness of the laminator itself.

Daily

- Clean the rollers
(See cleaning in this section)
- Inspect the electrical cord for damage.
(If damaged, you should replace or repair it immediately)

Monthly

- Adjust the nip if needed.
(Performed by a qualified Service Technician)
- Check the chain tension.
(Performed by a qualified Service Technician)
- Inspect the area around the laminator for possible hazards
(dust buildup, combustible items stored too close, etc.)

Semi-Annual

- Lubricate the chains, and gears.
(**Performed by a qualified Service Technician**)
- Check wire termination tightness.
(**Performed by a qualified Service Technician**)



CAUTION

Never clean the rollers with sharp or pointed objects. You may put irreparable cuts into the rollers.



**ELECTRICAL
SHOCK**

Remove power from the laminator before servicing. You can be severely shocked, killed or cause a fire.



CAUTION

Harden adhesive deposits on the rollers can cause damage to the rollers.

8.2 Cleaning the rollers



CAUTION

The following procedure is performed while the laminator is **HOT!**
Use extreme caution!



CAUTION

Do **NOT** pick or pull heat activated adhesive off the rolls when they are cold. You can cause irreparable damage to the laminating rolls.



WARNING

Heating components are **HOT!**
You can become severely burned !



INFORMATION

The most efficient time to clean the rollers is after a lamination process is completed.

Tools required

- Damp cloth
(Use water only to dampen the cloth)
- Rubber cement eraser
(a belt sander dressing block may be used instead)
- Several 100% cotton terry cloths
(best for lint free cleaning)
- 3M™ Scotchbrite™ pad



INFORMATION

The laminator will operate only when all safety latches are in the fully latched position.

- c) Press  on TOP TEMPERATURE and BOTTOM TEMPERATURE to 225°F (107 °C)

Preparation of the laminator

- a) Turn the **POWER** to the “I”.

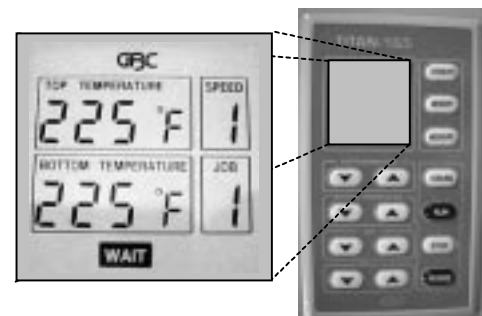

INFORMATION

If the rolls are heated, proceed to Removing adhesive build up..

- b) Ensure no **E-STOP** is depressed and all safety latches are in the fully locked position.

- d) Lower the main rollers.

e) Set speed to "1".

Removing adhesive build up

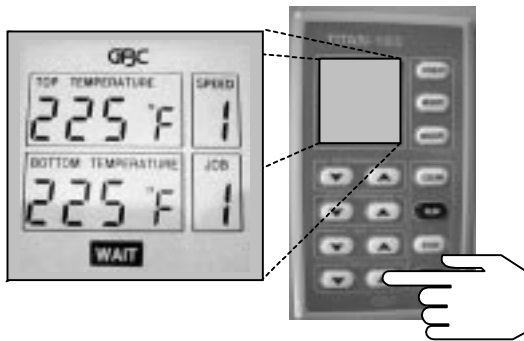

a) Raise the rollers.



f) Press **RUN**.



b) Press **STOP**.



g) When the **READY** is indicated on the display, proceed with Removing adhesive build up.



WARNING

Caution should always be exercised when using the laminator with the safety shields raised. You can be seriously HURT or INJURED!

c) Raise the front safety shield, remove the pressure plate and the feed table.



e) Replace the feed table and lower the front safety shield.

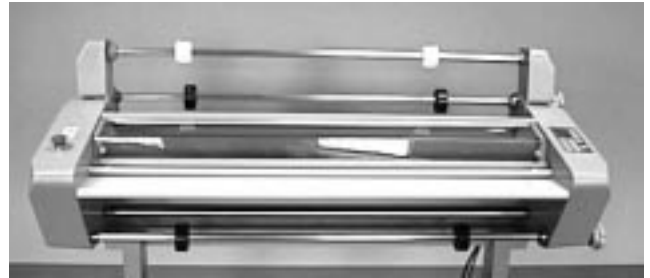

d) Use the rubber cement eraser to clean the nip rollers.



INFORMATION

Locator latches on the pressure plate are not associated with an interlock switch. The laminator will operate without the pressure plate installed.

f) Press **REVERSE**.



CAUTION

Excessive pressure can destroy the silicone layer by pressing too hard or scrubbing too long in one spot.





INFORMATION

Rollers only turn in reverse while depressing  .

h) Repeat steps “a” through “f” until the adhesive is beaded on the rollers.

b) Use a damp cloth to clean the beads of adhesives off of the rollers.

c) Replace the feed table and lower the front safety shield.



INFORMATION

Locator latches on the pressure plate are not associated with an interlock switch. The laminator can operate without the pressure plate installed.

Cleaning the beads of adhesives, dust and dirt

a) Press  on both temperature controls.

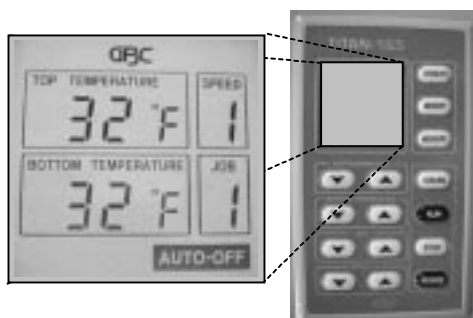

d) Press  .





INFORMATION

Rollers only turn in reverse while depressing **REVERSE** .

- e) Repeat steps “c” and “d” until the rollers are clean.
- f) Replace the feed table, pressure plate and front safety shield.
- g) Press **POWER** to “0”.



8.3 Clean the cabinets and covers



ELECTRICAL SHOCK

Remove power from the laminator before cleaning. You can be severely shocked, killed or cause a fire.

- a) Use a damp cotton terry cloth (water only), clean the exterior of the laminator.
- b) If water is not strong enough, you may use a mild dishwashing detergent with water and a cotton terry cloth.



ELECTRICAL SHOCK

Do not use liquid or aerosol cleaners on the laminator. Do not spill liquid of any kind on the laminator. You can be severely shocked, killed or cause a fire. Use only a damp cloth for cleaning unless other wise specified.

8.4 Cleaning the control panel



**ELECTRICAL
SHOCK**

Remove power from the laminator before cleaning. You can be severely shocked, killed or cause a fire.

- a) Use only a slightly damp (water only) non abrasive cloth.



**ELECTRICAL
SHOCK**

Do not use liquid or aerosol cleaners on the laminator. Do not spill liquid of any kind on the laminator. You can be severely shocked, killed or cause a fire. Use only a damp cloth for cleaning unless other wise specified.