



M2B

Temperature Control

Owners Manual

Rev. A



Dear Valued Customer,

On behalf of Sterling, we would like to express our gratitude and appreciation for choosing us as your supplier. We would also like to take this opportunity to introduce you to our complete offering of quality auxiliary equipment and services available for the process industries.



Full line of water and hot oil temperature control systems available in standard and custom configurations.



Air- and water-cooled chillers available in portable and central styles. Cooling tower systems, with full engineering capabilities.



Granulators, shredders, and size reduction systems. Available with vacuum take away and special hopper configurations.



Robotics, sprue pickers, and downstream automation. Custom end of arm tooling.



Quality OEM remanufacturing and updating of Sterlco water and hot oil temperature control units and components.

To obtain further information about any of these products, please feel free to call Sterling at either 1-800-783-7835 or 414-354-0970.



CONGRATULATIONS!

You are the proud owner of a Sterlco[®] Temperature Control System, the finest, most dependable unit available in today's market. Your Sterlco unit represents over 40 years of proven field service. We, at Sterling, are dedicated to manufacturing a temperature control unit that is second to none. Built by skilled craftsmen with the most modern and precise machinery available today. The simplicity of design and compactness engineered into the unit result in less maintenance and less floor space.

The Sterlco High Temperature Control Unit, designed and tested over a period of many years, represents one of the most significant advances ever in the field of self-contained, closed systems, portable units for heating natural or synthetic fluid and circulating it at controlled temperatures through molds, rolls, or jackets of processing equipment.

This Owner's Manual is intended to provide a complete overview of the unit and to give you step-by-step guidelines for the safe operation, care and service of your unit. We recommend that you thoroughly read this manual before initial start-up.

These standard units may have many variations of optional features added to them, relative to the customer's application or specific desires. The illustrations used are to help you identify certain parts by names and to understand our explanations, which will assist you later on in the Troubleshooting sections.

Units are warranted against defects in materials and workmanship for a minimum of one year from date of shipment. Any Sterlco unit which has been used contrary to specific operation instructions or materially altered, will not be covered by this warranty. Final determination of defects must be made at Sterling Inc.

By following the instructions in this manual and treating your equipment with care and respect due any precision equipment, you will be rewarded with years of uninterrupted, trouble free service.

Sterlco equipment must be attended while in use.



Table of Contents

Customer Service	4
Conventions Used in This Manual	5
M2B Microprocessor Controller	6
Introduction	6
Quick Start Instructions for the M2B Controller	7
Installation	8
Environment	8
Electrical	8
Security	8
Interface Panel	9
Indicator Lights	9
Input Keypad	10
Normal Operation Mode	11
Auto Vent	11
Tuning	12
Manual Tuning	13
Ramp/Soak	14
Basic Theory of Operation Ramp/Soak	14
Sample Ramp/Soak Program	17
Starting Ramp/Soak	19
Options	20
Remote Set Point	20
Retransmission of Process Variable	21
Second Set Point Input	21
Flow Meter	21
Remote Thermocouple Monitor	21
Communications	21
SPI Protocol	24
Diagnostic Error Messages	26
Fault Reset Procedure	26
High Temperature Oil Reconfiguration	27
Field Calibration	28
Audit Temperature Inputs	28
Electrical Specifications	31
General Specifications	32
Appendix A-Menu Selections	33
Appendix B-Mounting	37
Appendix C-Control Modes	38
Appendix D-Blank Ramp/Soak Profile	43
Appendix E-Glossary of Terms	44



Customer Service

Your unit was engineered and carefully assembled to give you excellent quality and years of trouble-free operation. If an unknown condition occurs, Sterlco has a well trained customer service group to assist you. We suggest the following for quick service.

Sterling Inc.

The customer Service Group is available from 7 a.m. to 6 p.m. (CST), Monday through Friday. The numbers to call are:

(800) 783-7835
(414) 354-0970
Fax (414) 354-6421

Before you call, be sure to do the following:

1. Refer to the **Troubleshooting** section of this manual.
2. Be sure to have this manual in front of you when you call.
3. Write down the symptoms or problem that you are experiencing.
4. Have your unit's model number and serial number available when you call.

Sterling Return Goods Authorization (RGA)

In order to better serve our customer's needs, we ask that before returning material or equipment of any kind, for any reason, that you call Sterling at 1-800-783-7835 for a return goods authorization number (RGA). This is a mandatory policy to help us identify returned goods, the reason for their return, and to help Sterlco expedite their processing. Failure to obtain this RGA number and mark it on the goods may result in their immediate return at your cost without being processed.

We thank you for your cooperation and understanding.

Heat transfer fluids must be drained and identified prior to shipment.

Please record your model identification number here for future reference. Refer to the description on Page 6 for more information.

601 00521

Conventions Used in This Manual

Sterling, Inc. - Parent company of Sterlco[®], Ball & Jewell[®], and Sterltech[®].

Sterlco - Manufacturer of water and oil temperature control systems, and water chiller systems.

BOLD CAP letters indicate a key on the M2B keypad.

“**DIGITAL**” text indicates the characters that are displayed on the LED windows. This manual shows the digital text as all caps, however, the actual readouts are a combination of caps and lower case letters.



CAUTION: A warning intended to prevent physical harm to the operator or equipment.

Note: Information to add clarity to the text.

The following illustration provides a reference for the side-bar illustrations:

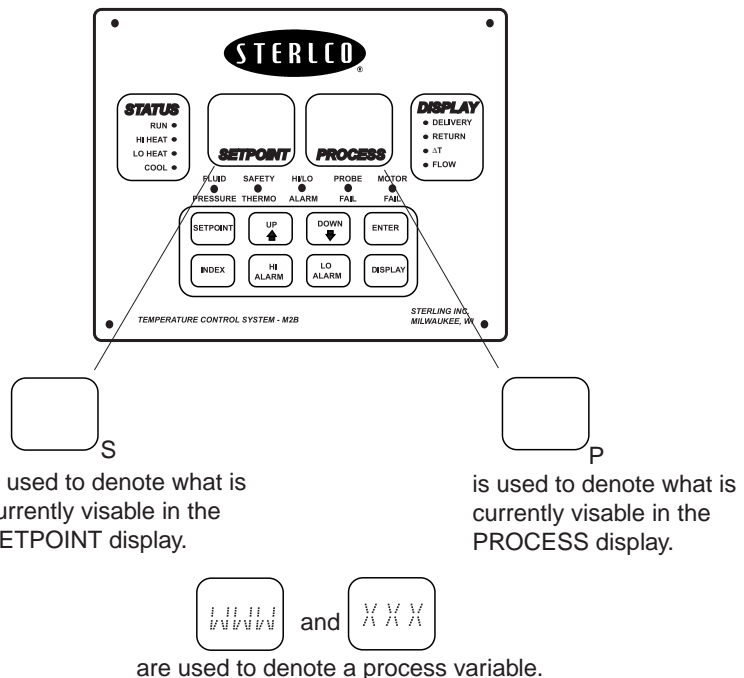



M2B Microprocessor Controller

Introduction

The M2B is a microprocessor based process controller designed for exclusive use with the Sterlco Temperature Control Units. The M2B monitors and maintains the temperature of the fluid in any given process to a selected set point using a unique proportional integral derivative (PID) auto-tuning program. The controller employs PID algorithms and fuzzy logic to automatically tune the system to heat or cool the fluid as required by the process.

The M2B has LED displays for set point and process temperatures. Controller status lights are provided for the following functions: cool, heater high/low, run, flow, return and delivery temperatures, and temperature differential.

The controller includes self-diagnostics to check hardware functions. Diagnostic lights are provided for the following functions: low fluid pressure, safety thermo, high/low alarms, delivery and return probes, and motor fail.

The M2B is panel mounted and has a membrane keypad with tactile feedback. When properly installed with a sealing gasket, the M2B is safe for water washdown.

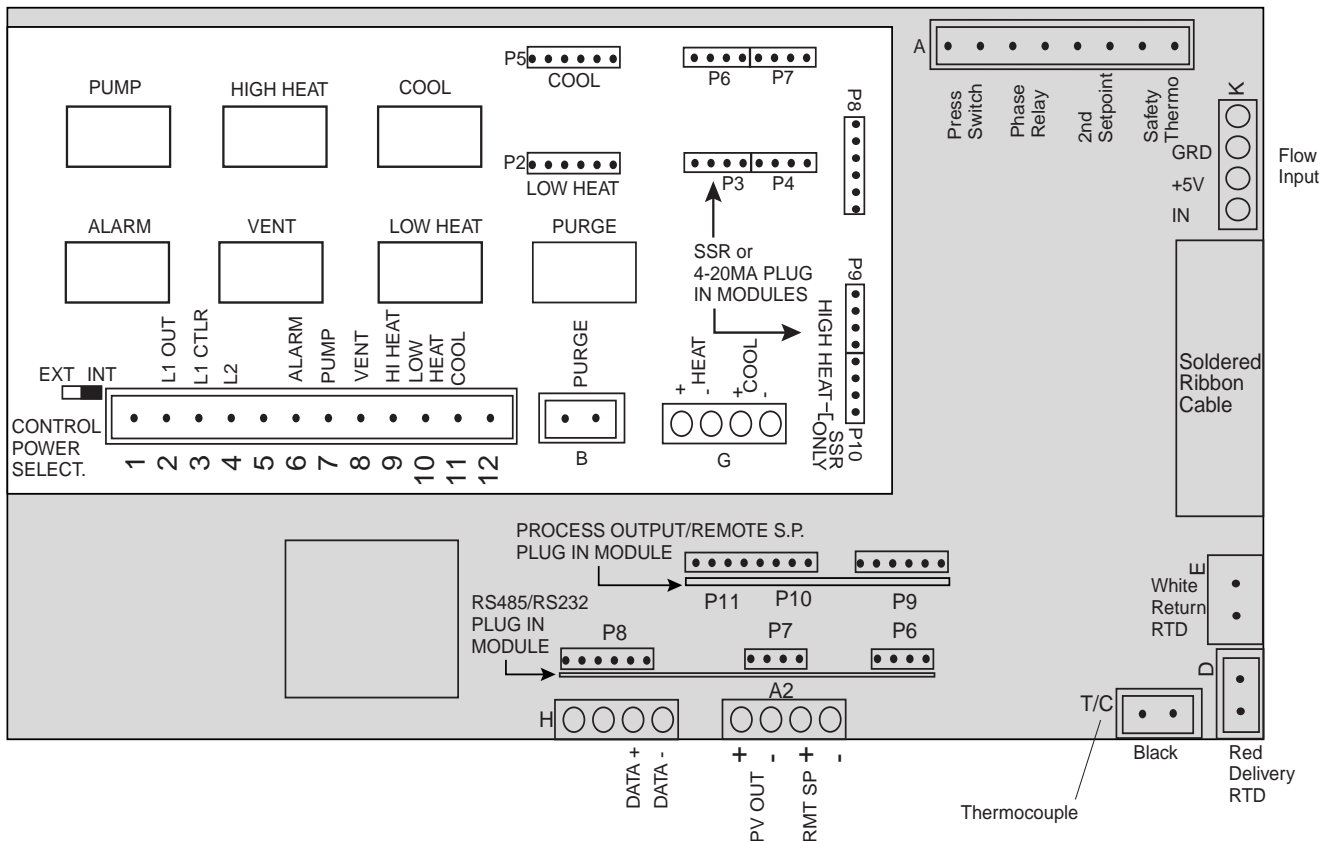

Lowest Level Board contains Serial Label - lower left.

Figure-1



Quick Start Instructions for the M2B Controller

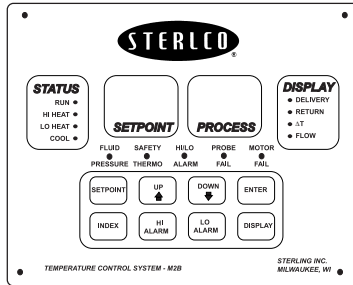

The quick start instructions can only be used provided the M2B is properly installed and wired.

Turn unit on - The "SETPOINT" and "PROCESS" LED displays will read "888".

Wait 3 sec. - The LED displays will read "TST" and "SLF".

Wait 3 sec. - The LED displays will read "UNT" and "XXX", where "XXX" equals the current process temperature.

Wait 1 to 5 min. for Vent sequence. - The LED displays will read "WWW" and "XXX", "WWW" equals the process setpoint. "XXX" equals the current process temperature.

The process is now running. The setpoint may now be adjusted for your installation. Press **SETPOINT**. Use **ARROW** to adjust.

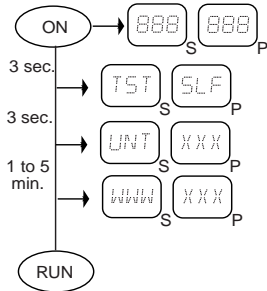

Model Identification

To determine the options that are included with the M2B, use the following configurator. The character "X" represents an option that is included.

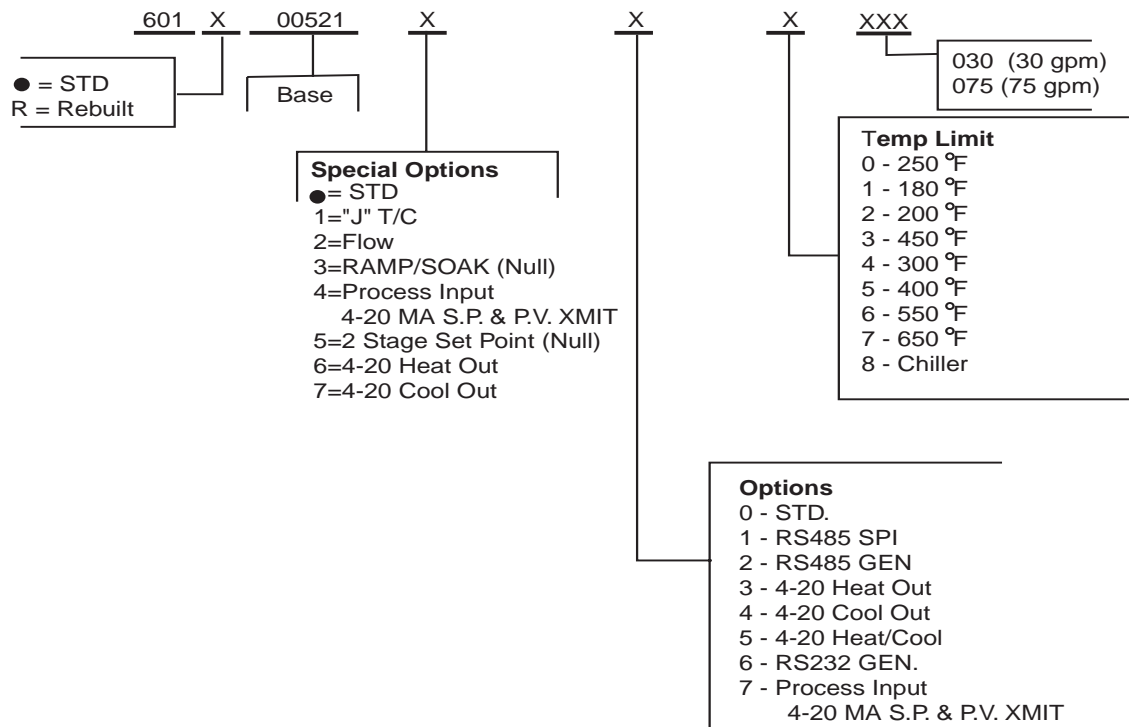



Installation

Environment

Mount the instrument in a location that will not be subject to excessive temperature, shock or vibration. All models are designed for mounting in an enclosed panel.

When properly mounted in an enclosed panel using a gasket at the panel/controller interface, the keypad can be washed down with water. Do not use high pressure fluids.

Microprocessor based instruments require a “clean” source of power that is steady and free of noise. Electrical noise may be caused by line faults, power switching, motors, motor controllers, or power controllers containing SCR devices. Without a clean source, any microprocessor is prone to failure.

Electrical



CAUTION: Electrical noise is created by devices that are connected to a controls output load circuit. Field coils from contactors or solenoids are a common source of electrical noise. These conditions may interfere with the operation of the M2B controller.

If your power source is not from a clean line, your system can be protected by installing a Line Filter.

Where external contactors or solenoids are used with relay output instruments, an R/C Snubber Network should be used. The snubber installs easily directly across the field coil terminals of the relay or solenoid.

Do not run thermocouples, RTD's or other class 2 wiring in the same conduit or area as power leads. Maintain separation between wiring of sensors, process signals and other power and control wiring.

Security

Passwords are used to prevent access to critical menus. Four levels of security are provided. The display shows the current security level. Security levels are changed by changing the password value using the **UP** and **DOWN** arrow keys and pressing the **ENTER** key. Refer to the password table below for the correct value to enter for the security level desired. The **SEC** menu item security level may be viewed or changed at any time regardless of the present security level.

For example, to set the access level to "2", at the **SEC** menu item press the **UP** arrow key until the upper display shows the password, 101. Press the **ENTER** key. The display will blink, and return with the level value, "2", in the Process display.



Menu	Security Level Status	Displayed Value When Viewed	Password Value To Enter
Home Secondary Secure	Locked Locked Locked	1	110
Home Secondary Secure	Unlocked Locked Locked	2	101
Home Secondary Secure	Unlocked Unlocked Locked	3	011
Home Secondary Secure	Unlocked Unlocked Unlocked	4	111

Interface Panel

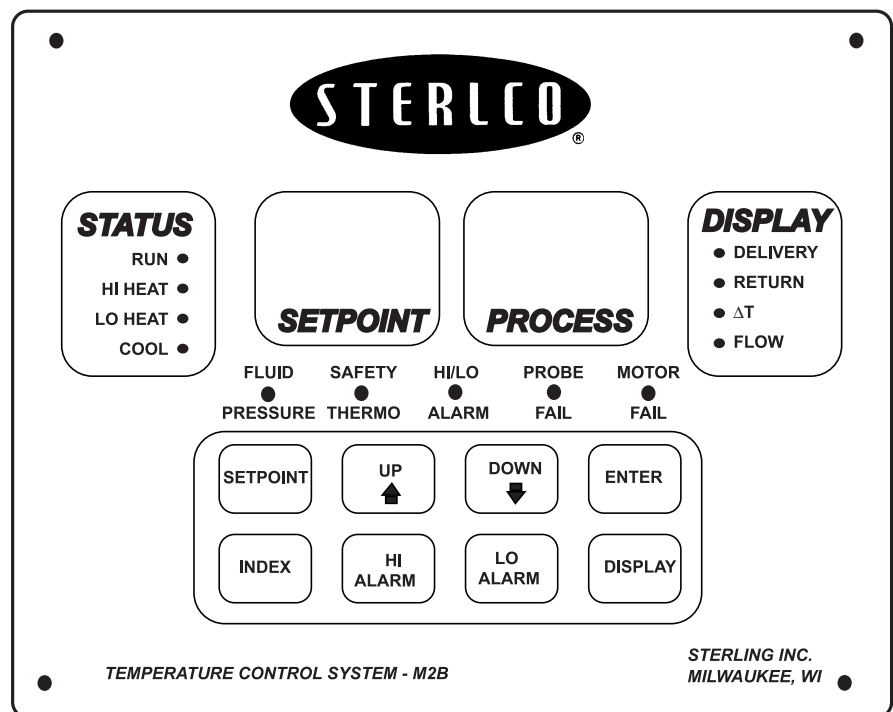

Figure-2

Note: Depressing the **DISPLAY** keypad, the function LED will stay on for thirty (30) seconds, then revert to the default delivery display.

Indicator Lights

Status Lights

- RUN - Flashes while controller is auto-tuning. Glows steady during normal operation.
- HI HEAT - Fluid heaters are on Hi to rapidly raise the fluid temperature.
- LO HEAT - Fluid heaters are at 50%.
- COOL - Fluid temperature is above setpoint and is being cooled.



Display

- DELIVERY - The process display is showing the temperature of the outgoing fluid.
- RETURN - The process display is showing the temperature of the incoming fluid.
- ΔT - The process display is showing the difference between delivery and return temperatures.
- FLOW - The process display is showing the flow of the fluid in GPM or LPM. Must have optional flow sensor.

Alarms

- FLUID PRESSURE - Fluid pressure low. Unit shuts down and will resume operation when pressure is restored (disabled in oil units).
- SAFETY THERMO - Over temperature fault. Heater outputs are disabled. Pump continues to operate and the "cool" solenoid is energized. This is a fatal fault which requires the main power to be disconnected to reset the M2B.
- HI/LO ALARM - The alarms can be set individually via the keypads. The HI deviation is +200 °F (+93.3 °C) above the setpoint. The LOW deviation is -100 °F (-37.7 °C) below the setpoint. Oil temperature control unit alarms are set to "OFF" as default and must be activated through the keypad if needed. The alarm settings can be changed to absolute, "ABS" in the secondary menu. Alarms reset automatically.
- PROBE FAIL - A temperature sensing probe has failed. A delivery probe fail will display "DEL" in the display. Failure of the return probe will display "RET". The alarm will reset when the probe is replaced.
- MOTOR FAIL - Improper pump rotation, motor out of phase or thermal overload. This is a fatal fault which requires the main power to be disconnected to reset the M2B (water units only).

Input Keypad

Depressing any program keypad (**SETPOINT**, **HI ALARM**, **LO ALARM**) displays the stored value and allows the parameters to be adjusted. The following programmable features are allowed by the M2B.

- PROGRAM SETPOINT - Depress and hold the **SET POINT** keypad and either the **UP** or **DOWN** arrow to increase or decrease the set point display.
- PROGRAM HI ALARM - Depress and hold the **HI ALARM** and either the **UP** or **DOWN** arrows to set the alarm high limit. To disable the function, set the limit out of range or go into the secondary menu by depressing the **UP** and **ENTER** keys together. Use the index key to access the "RL" function. Use the **UP** or **DOWN** key to select "OFF". Depress **ENTER** to accept the function change.

Note: The controller will automatically program a high alarm of +200 °F (+93.3 °C) above set point and -100 °F (-73.3 °C) below setpoint.

- **DISPLAY** - Depressing the **DISPLAY** keypad scrolls through the display menu. Each depression indexes to the next available function. The display function will return to delivery temperature after thirty (30) seconds.
- **UP ARROW** - Increments a value, continued pressing will cause the value to gradually increment at a faster rate.
- **DOWN ARROW** - Decrements a value, continued pressing will cause the value to decrement at a faster rate.
- **ENTER** - Used only in conjunction with the home menu (index pad) or the secondary and secure menus. Pressing **ENTER** stores the value or the item changed. If not pressed, the previously stored value or item will be retained.
- **INDEX** - Pressing the **INDEX** key advances the display to the next menu item. The following functions are accessible by the **INDEX** key (see Appendix A for more information):
 - Tune
 - Fuzzy Logic
 - Auxiliary set point
 - Thermocouple Monitor
 - Flow Alarms
 - Autovent on-Off and Duration 1 to 5 min.
 - High/Low Heat Select
 - Ramp/Soak Run/Hold
 - Segment Time Remaining
- **UP and DOWN ARROWS** - Depressing the **UP** and **DOWN** arrows simultaneously activates an optional output normally used for purge options.
- **UP and ENTER** - Depressing the **UP** and **ENTER** keys simultaneously will access the “secondary menu”. The following functions are accessible in this menu (see Appendix A for more information):
 - °F/ °C Select,
 - Alarm: On-Off/Lo/Hi/Hi/Lo
 - Event
 - Ramp Soak,
 - Loop Break On-Off
 - Percent Output Display
 - Communications I.D.
 - Proportional Output/Input Scaling

Depress and hold for 30 seconds to enter the secure menu. All outputs are disabled.



CAUTION: Any changes will effect system operation.

Normal Operation Mode

Auto Vent:

Display “**VNT**” in the set point display for duration of auto vent condition 1 to 5 minutes, adjustable. The auto vent feature is deactivated on high temperature oil units and chillers.



Tuning

Note: The M2B is shipped with preset tuning parameters. To quickly adapt the M2B to your process, you may elect to tune the controller at start-up. Read this section entirely before initiating operation.

The M2B features Fuzzy Logic. Manual tuning is not necessary.

Fuzzy Logic is a term that describes the decision process within the controller. This controller has the programmed ability to “consider” inputs and change process information accordingly. One analogy would be a human trying to hit a target. The first attempt is recorded and the brain makes continual process corrections until an acceptable tolerance is reached.

The M2B controller also has multiple tuning conventions available to adjust to your process. Tuning choices are:

- Self
- Manual PID Input
- Slow
- Nor
- Fast

These tuning methods will speed up the Fuzzy Logic process.

Self-autotuning may be considered when initial start-up is performed or the mold and/or the process is changed.



CAUTION: The factory default for the M2B is automatic half/full heat. If an autotune cycle is completed do not switch to low heat without performing a new autotune cycle. Failure to autotune will result in poor control of the process. Subsequent changes from one heat setting to another require autotune to be run.

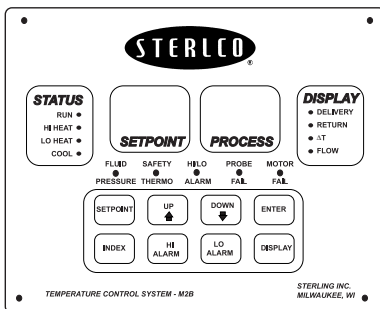

Initiate Autotuning:

The controller will evaluate the process and select the P, I, D and Fuzzy Logic values. To maintain control:

1. Turn the control power switch to ON.
2. Press **SETPOINT**.
3. Use **UP/DOWN** arrows to adjust setpoint.
4. Allow completion of Autovent (“VNT” in set point display).
5. Press **INDEX** keypad until “TUN” appears in the display.
6. Press **UP/DOWN** arrows until “SLF” appears in the display.
7. Press **ENTER**.
8. The Run Lamp will flash during the entire Autotune process.
9. Press **INDEX** keypad until “LRN” and “YES” appear in the displays. Use the **UP/DOWN** arrows to select “NO” to cancel the tune.
10. Press **ENTER**.

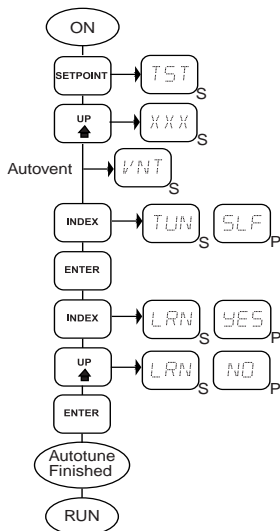

Do not attempt to reprogram the M2B or depress any keypads while the “RUN” LED is flashing, as this will cancel the autotuning process.

For best Autotune results, start with a stabilized process temperature (no rapid rises or drops in temperature).

Manual Tuning Procedure (Zeigler-Nichols PID Method):

This tuning method may be used if the spread between ambient temperature and process operating temperature is small. For best results, the use of a recording device is required when tuning with this method:

1. Disable the cooling output. Set "OT2" in the score menu to "ONF".
2. Set the reset (integral), the rate (derivative), and the fuzzy intensity (FPC) to zero. Set the proportional band (PBH) to 100.
3. Adjust setpoint to the desired value.
4. While monitoring the process temperature or recording device, decrease the proportional value by repeatedly halving the value until a small, sustained temperature oscillation is observed. Measure the period of one cycle of oscillation "T".
5. Divide the period of oscillation "T" by eight, the resulting number is the correct rate, "RTE" time in seconds. Multiply this number by four. This is the correct reset "RES" time in seconds.

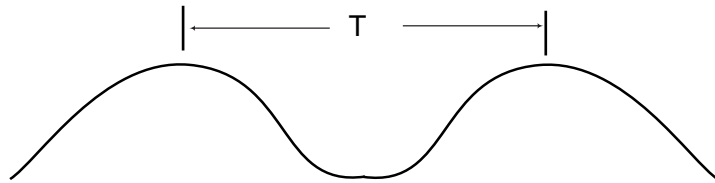
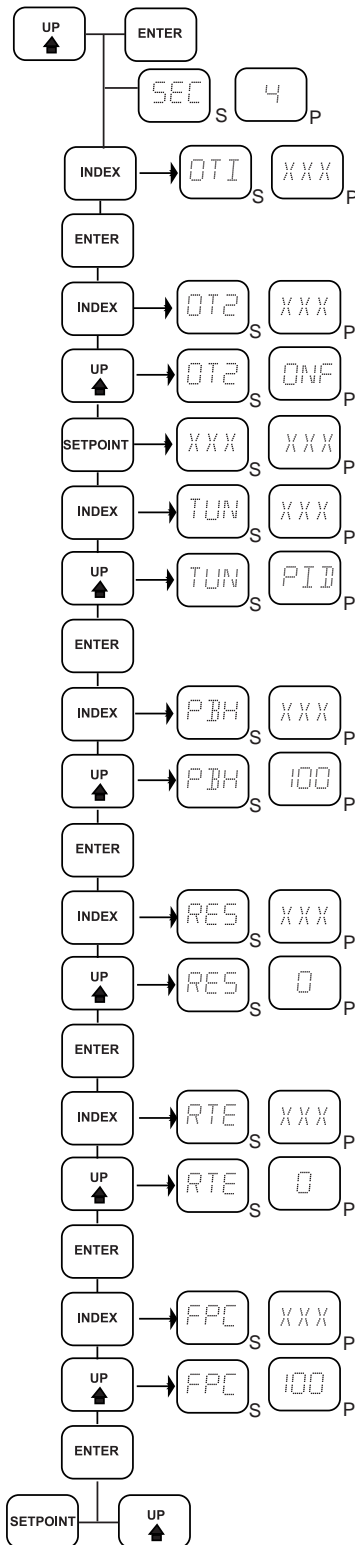

6. Multiply the bandwidth value "T" by 1.66, enter this as the new proportional "PBH" value.
7. Reset the cool output "OT2" to "PRP".
8. Reset the fuzzy intensity "FPC" to 50.



Manual Proportional Integral Derivative (PID):

Allows the operator to manually input P, I and D parameters into the controller. These parameters are fixed as long as the controller is in this mode.

Slo, Nor, or Fast:

Heat/Cool PID quick tune pre-determined parameters. Selectable through the keypad. See table below for Reference Settings.

Index	Reference Settings For Manual PID Input					
	Slow Response System		Medium Response System		Fast Response System	
	Air Cooled	Water Cooled	Air Cooled	Water Cooled	Air Cooled	Water Cooled
Pb1 Heating Band	12	12	8	8	6	6
Pb2 Cooling Band	12	20	8	12	6	10
db DeadBand	0	0	0	0	0	0
rES Reset	20.0	15.0	7.0	5.0	3.0	2.0
rtE Rate	1.67	1.25	0.58	0.42	0.25	0.17

Ramp/Soak



The controller is provided with a 16 segment, front programmable Ramp/Soak feature. Unused alarms can be programmed as a segment.

Caution: Do not operate the auto-tune while a ramp/soak function is operating.

Ramp/Soak is one of the many features that add process programming capabilities to the M2B controller. This section will deal only with the Ramp/Soak programming operation.

Basic Theory Of Operation Ramp/Soak

The M2B controller is user friendly. It offers an easy way to program a ramp. Instead of requiring the operator to calculate an approach rate, the M2B does the calculation automatically. The operator needs to program the target set point and the time desired to reach that set point. When the ramp segment is executed by the controller, it calculates the ramp required to reach the process temperature from starting set point to the programmed set point in the time allowed.

Dwells (or soaks) are ramp segments with target set point equal to starting process temperature. This allows for multistage ramps without wasting intermediate soak steps.

IMPORTANT! Test any program for best results before running production material.



Caution: Make sure to run auto-tune before operating Ramp/Soak because Ramp functions will interfere with the operation of auto-tune.

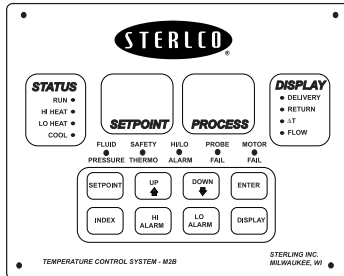

Ramp/Soak Set Up

Before programming Ramp/Soak, evaluate your program on paper. To program Ramp/Soak function, enter the secondary menu (pressing **UP** and **ENTER** keys simultaneously).

- Press **INDEX** key repeatedly until “PRG” appears.
- Use the **ARROW** keys to change to “OFF” (if it is on).
- Press **ENTER**.
- Press **INDEX** once, “SET” should appear.
- Use the **ARROW** keys to change to “ON” (if it is off).
- Press **ENTER**.
- Press **INDEX**. “STA” should appear.
- Skip this parameter for now, and press **INDEX** once more. “SEC” will appear.
- Use the **ARROW** keys to select time base (seconds or minutes).
- Press **ENTER**.
- Press the **INDEX** key until “ITI” appears.
- From this point, pressing **INDEX** will display the following items in the following order:
 “ITI”, “ISP”, “IR1” and “IR2”---“BTI”, “GSP”---“RTI”, “ASP”---“GTI”, “GSP”

Alarms 1 and 2 display only if they are programmed as an event.
 To eliminate repetition, each item will be described once.

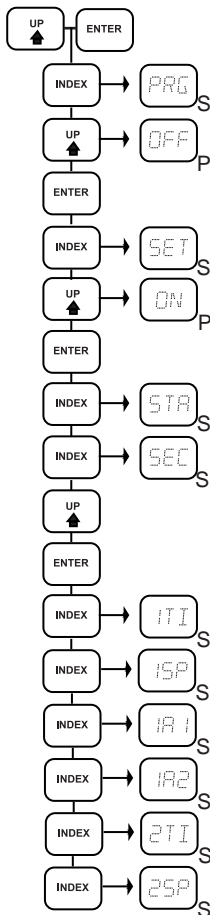

Through 16 points

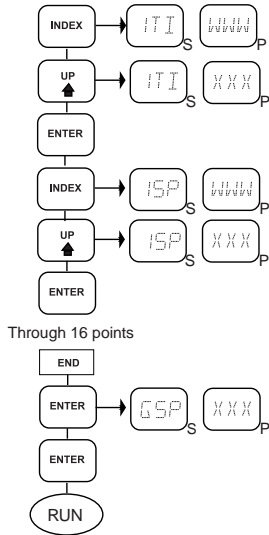
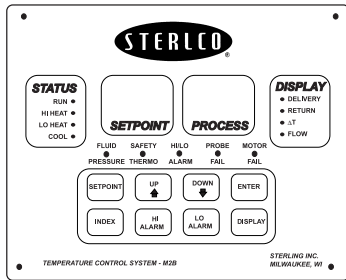

- For the first ramp, set “**ITI**” to the required time. This value is in time units from 0 to 999 (seconds or minutes).
- Press **ENTER**.
- Press **INDEX**, set “**ISP**” to target set point for the first ramp. The units of this value are the same as normal set point (SP1).
- Press **ENTER**.
- If alarm 1 is programmed as an event, then “**IR 1**” will appear when **INDEX** is pressed. If alarm 1 is required for this segment, set “**IR 1**” for **ON**, if not, set for **OFF**.
- If alarms 1 or 2 are not programmed as an event, the “**IR 1**” and “**IR 2**” will not appear. If “**IR 1**” or “**IR 2**” are set to **ON**, alarm 1 or 2 will be active for the period of “**ITI**” and “**IT2**”.
- Set the segment times (“**ITI**”---“**GTI**”), segment set points (“**ISP**”---“**GSP**”), event alarms (“**IR 1**”---“**IR 2**”), if they exist.
- For the segments that are not used, set the segment times to 0, and segment set points to the same value as the last active set point.
- Event alarms may be set as necessary.
- **END** is the last menu item for the Ramp/Soak function. **END** determines what the controller does when the program has ended.
- To set the program to repeat, select (“**L OP**”).
- If (“**L OP**”) is selected, it is important to allow the process to return to the same condition that existed when the program first started.
- To hold last set point (“**GSP**”), select (“**HL I**”).
- Turn off outputs at end of program, select (“**OFF**”).
- Press **ENTER** to accept your choice.



Sample Ramp Soak Program

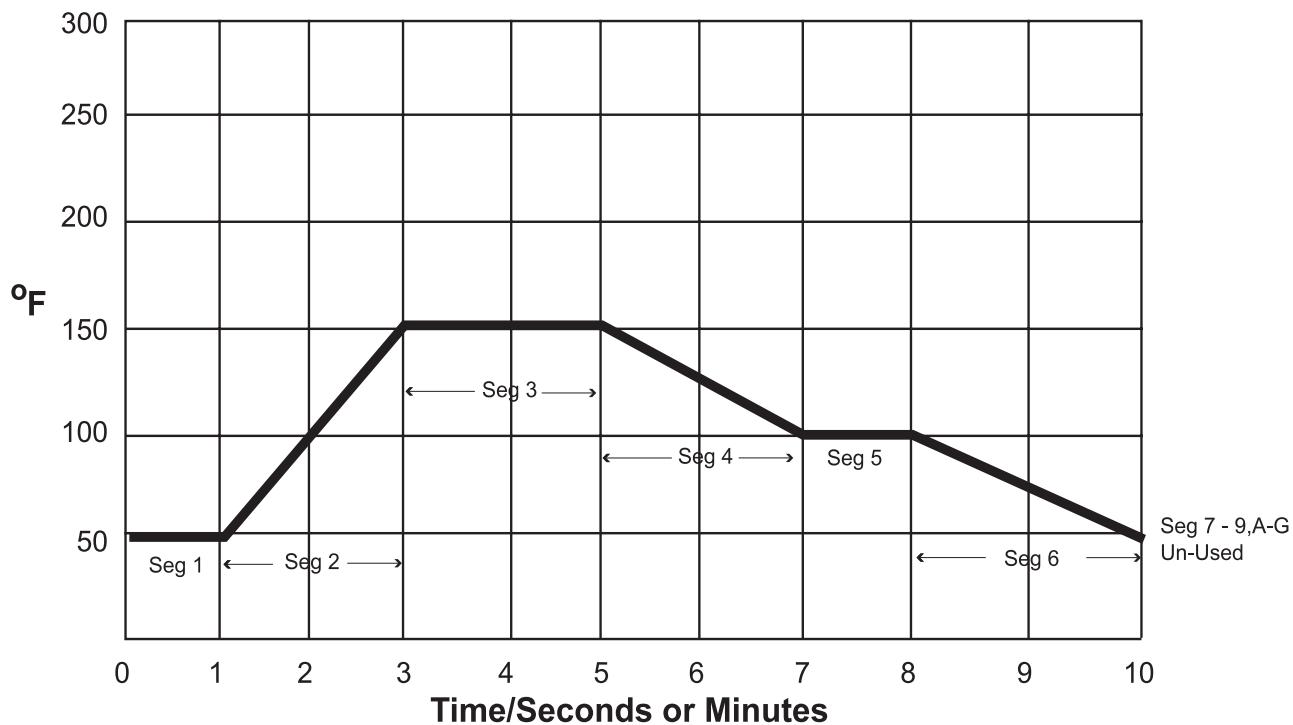

Segment Prompt	Function	Time (Min.)	Setpoint °F
1TI	1st Event	1	
1SP			50
2TI	2nd Event	2	
2SP			150
3TI	3rd Event	2	
3SP			150
4TI	4th Event	2	
4SP			100
5TI	5th Event	1	
5SP			100
6TI	6th Event	2	
6SP			50
7TI	Un-Used	0	
7SP	Hold Last Setpoint		50
↓	Un-Used		
GTI	Un-Used	0	
GSP			50
END	Stay at present set pt. (gSP)		HLd
END	Turn off outputs at end of program		Oof
END	Repeat program at 1TI		Lop



The following flow chart diagrams the sample Ramp/Soak procedure.

Enter the secondary menu. Follow the "Ramp/Soak setup" steps to reach 1TI.

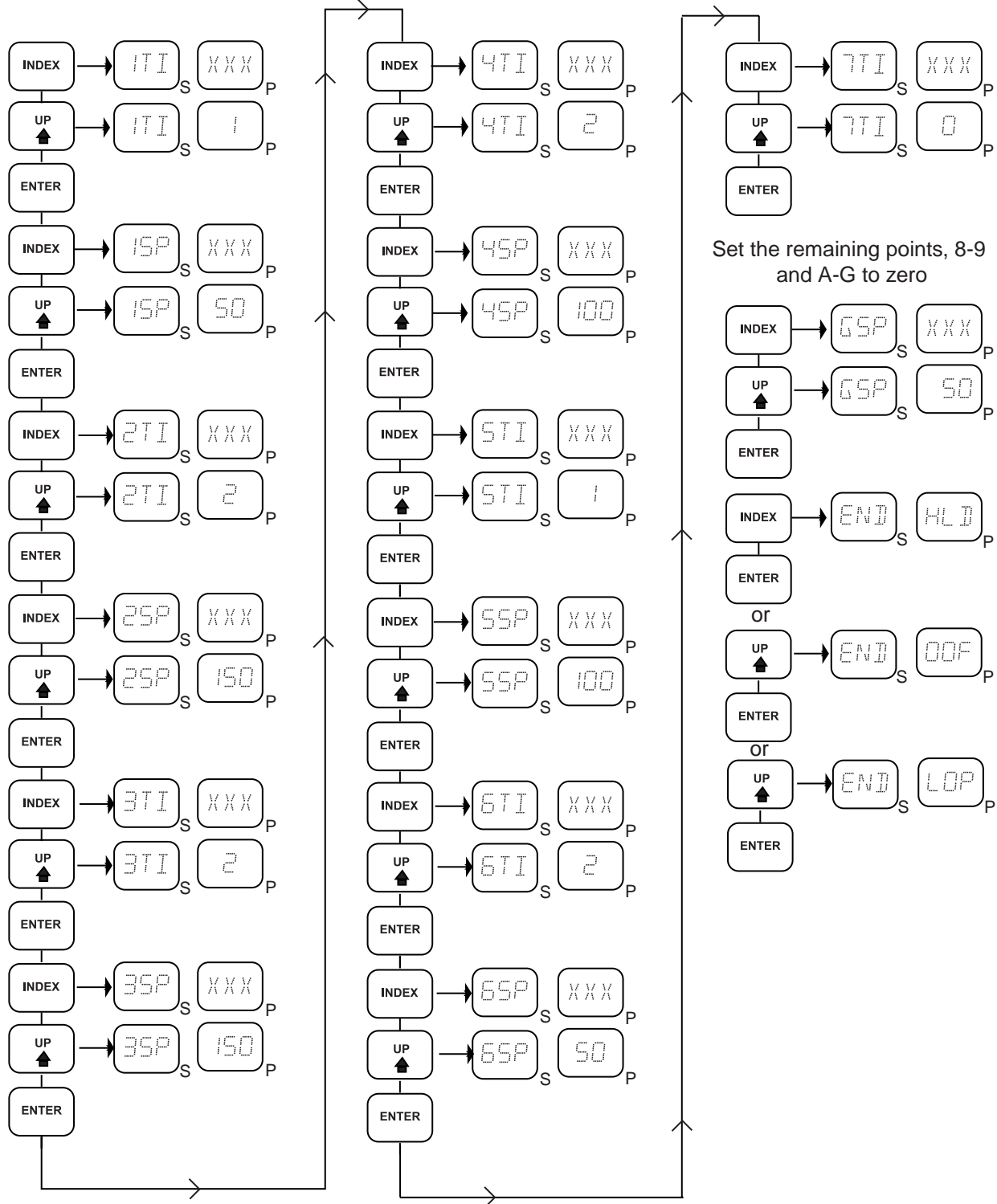

This program is now ready to run. See Starting Ramp/Soak.

Starting Ramp/Soak

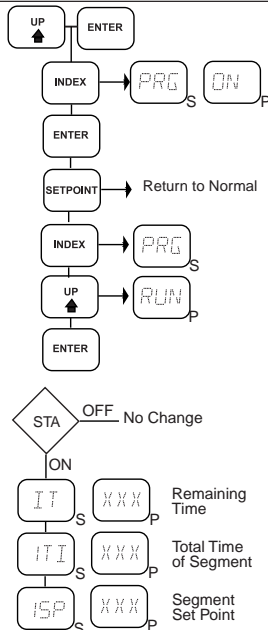
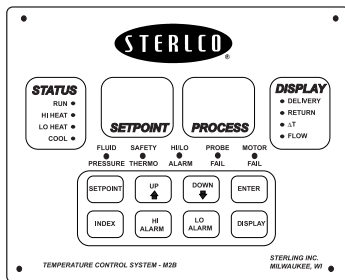

- To run the program, enter the secondary menu and set the “PRG” menu item to “ON”.
- Press **ENTER**.
- Return to normal display by pressing **SET POINT** key or waiting for the display to time out.
- Press **INDEX** key once, “PRG” will appear.
- Use the **ARROW** keys to change to “RUN” (if it is “HL D”).
- Press **ENTER**. The primary menu will change depending on the setting of “STA” menu item in the secondary menu. If “STA” is off, there is no change. If “STA” is set to on, the primary menu has three additional information items added after “PRG” appears:
 - “IT” displays remaining time in the current segment
 - “ITI” displays total time of active segment
 - “ISP” displays the segment set point (“ISP”---“GSP”).

To exit primary menu, press **SET POINT** key.

For Example: $250\text{ }^{\circ}\text{F} = (250^{\circ}\text{F}/20\text{Ma} - 4\text{ mA}) 20\text{mA} + b$
 $-62.5 = b$ ("R5L")

Retransmission Of Process Variable

The M2B is capable of re-transmitting the process output "INP" or the set point input "SPI" via a 0-20mA analog signal. If a 4 to 20mA output is desired, follow the scaling calculation outlined in the remote set point section. Insert the low and high values for "POL" and "POH".

Second Set Point Input

The M2B is provided with a secondary set point "2SP" pre-programmed for 0 °F (-17.7 °C), but is adjustable. When an external switch contact is closed, the controller will switch to this set point and will display "WNT". This will occur when SP2 is set to 0 °F and the actual setpoint is any other value. The controller will revert to "SP1" when the contact is released and unit returns to run mode.

Flow Meter

The M2B is capable of displaying and alarming process flow in gallons per minute (GPM) or liters per minute (LPM), via a factory installed flow sensor. The M2B is capable of accepting numerous flow sensors.

Note: Please contact the factory if the flow readout oscillates or appears erratic for evaluation, calibration, and installation instructions.

The M2B is equipped with a software activated digital filter. The filter is adjustable from 0-100, the larger the number the greater the signal dampening. Consult the factory for further information and access.

Remote Thermocouple Monitor

Monitors type "J" thermocouple input. Depress **INDEX** key until "TC" appears. Temperature is displayed in process display window. See Figure-1 for location.

Communications

The Sterling M2B controller can communicate with a host machine via a half or full duplex RS232 or RS485 communication link.

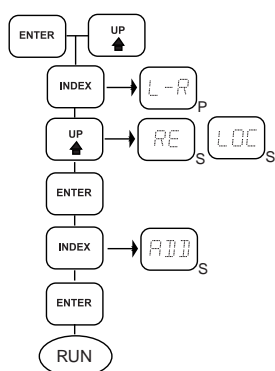

- Press and hold the **UP** and **ENTER** keys to access the secondary menu.
- Use the **INDEX** key until "L -R" appears.
- Use the **UP** or **DOWN** keys to select "LOC" or "RE".
- Depress **ENTER** to accept your selection.
- **INDEX** to "ADD" to select the controller address "1 to 3FF".
- Depress **ENTER** to accept your selection.

Note: All data is sent and received in the ASCII hex character format, using 10 bits: 1 Start bit, 8 data bits, no parity and 1 Stop bit.

Any changes in the communication protocol should be made by qualified technicians.

Host will be used to describe the computer operating as the originator of communications. **Instrument** will be used to describe the process control(2) using this protocol. In the following examples, only **Host** and **Instrument** will be used.



1. The “L” (ASCII 4C hex) is used as a filter character in the examples below. The filter characters are specific. The filter character changes according to the **Instrument’s** address.

(ASCII 4C hex) = **Instrument** addresses 01 through FF

(ASCII 4F hex) = **Instrument** addresses 101 through 1FF

(ASCII 56 hex) = **Instrument** addresses 201 through 2FF

(ASCII 43 hex) = **Instrument** addresses 301 through 3FF

Addresses 00h, 200h and 300h should not be used. These are for Factory Service use only.

2. The checksum generated by the **Host** is obtained by adding all ASCII characters in hex, excluding the <stx>, filter character, and the <etx>. Only the lowest 8 bits are used. The checksum is inserted into the message between the data field and the <etx>.

Example: **Host** checksum calculation

	32h	0100h	26h	
<stx> L	<addr>	<---data--->	<cksm>	<etx>
02 4C	33 32 30 31 30 30		32 36	03
	<-----cksm----->			

$$33+32+30+31+30+30 = 126h \text{ (use only the low byte)}$$

3. The checksum generated by the **Instrument** is obtained by adding all ASCII characters in hex, excluding the <stx> and the <ack>. Only the lowest 8 bits are used. The checksum is inserted between the data field and the <ack>. Note that the filter character is included in the checksum calculation by **Instrument**.

Example: **Instrument** checksum calculation

	32h	0100h	26h	
<stx> L	<addr>	<---data--->	<cksm>	<ack>
02 4C	33 32 30 31 30 30 31 35		44 38 06	
	<-----cksm----->			

$$4C+33+32+30+31+30+30 +31+35 = 1D8h \text{ (use only the low byte)}$$

4. Checksums are generated for all **Host** commands
5. Checksums are generated for all normal **Instrument** responses. A checksum is not sent when errors are reported to the **Host**.



Command And Response Example Notations

1. [nu]: "not used" at present time, (for future expansion). Undefined data, data returned should not be used.
2. <Data>: These are ASCII characters shown in Hex notation. The upper case alpha character set is used for values A through F. (ASCII 46h - F, ASCII 33h - 3). Lower case is not used.

<u>ASCII Control Character</u>	<u>ASCII in hex</u>	<u>Description</u>
<stx>	02	Start of Text
<etx>	03	End of Text
<ack>	06	Acknowledgment
L	4C	Filter Character
00N		Process Variable Value
100N		Read Set Point Value
200H		Write Set Point Value

Error Messages Reported

Example:Checksum error detected by **Instrument** at address 32

Instrument responds to **Host's** last command with Error message

```

<stx>      L      <addr>  N      <error code>  <ack>
                32h  N          02h
02         4C   33 32  4E      30 32          06

```

(Note the absence of Checksum)

N - ASCII character (4Eh) used to denote Error Present

Table Of Error Messages Possible From Instrument

<error code>

- 00 - Not used.
- 01 = Undefined command. Command not within acceptable range.
- 02 = Check-sum error on received data from **Host**.
- 03 = Command not performed by Instrument (option not enabled, restricted read/write menu, check message)
- 04 = Illegal ASCII characters received in command. **Instrument** accepts only ASCII characters 0 through 9. A through F and a through f in data field.
- 05 = Data field error. Not enough, too many, or improper positioning of characters in data field.
- 06 = Undefined command. Command not within acceptable range.



07 = Not used.

08, 09 = Hardware fault. Return to Factory for service.

10 = Undefined command. Command not within acceptable range.

SPI Protocol

The Society of the Plastics Industry (SPI) communication protocol specifies a connection management Protocol, a packetized communication format, and communication error mechanisms passing commands and data between a host computer and a slave. A host computer initiates all communications. The protocol used corresponds to the 3.01 version of the SPI communication protocol specification dated October, 1990. The data is transmitted via a multidrop EIA-485 (half-duplex) hookup. The character format required is 1 start bit, 8 data bits, no parity and 1 stop bit.

The M2B controller will support a number of commands that will allow the host computer to retrieve status and assign set points. The commands correspond to a mold temperature controller device.

Commands

Descriptions

Commands	Descriptions
(CMD1) (CMD2)	
(20H) (20H)	Echo poll — Controller integrity command. Return the 4 bytes of ASCII assigned by the Echo Select command in an open format.
(21H)	Echo Select — Controller integrity command. Supplies 4 bytes of ASCII in an open format that is to be returned when an Echo Poll command is received.
(22H)	Version poll — Returns a version number (AABB = 0101) as 4 bytes of ASCII in an open format where: AA = SPI assigned version level BB = Vendor assigned version level
(30H)	Set point poll — Returns the current process set point value in numeric format.
(31H)	Set point select — Assigns a value to the process set point in numeric format.
(32H)	Alarm, high temperature deviation poll — Return the high temperature deviation set point value in numeric format. This value when added to the process set point gives the temperature at which a high alarm will occur.
(33H)	Alarm, high temperature deviation select — Assigns a value to the high temperature deviation set point in numeric format.
(34H)	Alarm, low temperature deviation poll — Returns the low temperature deviation set point value in numeric format. This value when subtracted from the process set point gives the temperature at which a low alarm will occur.
(40H)	Status process poll — Returns the status of the process as 16 flag bits in open format. The following bits are supported. The rest are set to 0. Bit 0 — Processing Bit 1 — Alarm, System Bit 2 — Alarm, Process



- Bit 3 — Alarm, Machine
 - Bit 4 — Alarm, High Temperature
 - Bit 5 — Alarm, Low Temperature
 - Bit 7 — Alarm, Low Pressure
 - Bit 9— Alarm, Low Flow
- (42H) Status, machine 1 poll —Returns the status of the machine as 16 flag bits in open format. The following bits are supported. The rest are set to 0.
- Bit 0 — Processing
 - Bit 1 — Alarm, System
 - Bit 2 — Alarm, Process
 - Bit 3 — Alarm, Machine
 - Bit 4 — Alarm, High Temperature
 - Bit 5 — Alarm, Low Temperature
 - Bit 7 — Alarm, Low Pressure
 - Bit 14 — Alarm, Phase Reversed or Lost
- (44H) Status, machine 2 poll —Returns the status of the machine as 16 flag bits in open format. The following bits are supported. The rest are set to 0.
- Bit 0 — Processing
 - Bit 1 — Alarm, System
 - Bit 2 — Alarm, Process
 - Bit 3 — Alarm, Machine
 - Bit 4 — Fault, Sensor, Delivery
 - Bit 5 — Fault, Sensor, Return
- (48H) Mode, Machine Poll —Returns the current status of temperature control unit if the machine is On (1) or Off(0).
- (49H) Mode, Machine Select —Commands the temperature control unit to turn On (1) or Off (0)
- Bit 0— Machine On/Off
 - Bit 1 — Alarm Acknowledge
- (70H) Temperature, to process poll —Returns the delivery temperature in numeric format.
- (72H) Temperature, from process poll —Returns the return temperature in numeric format.



Diagnostic Error Messages

DISPLAY	DESCRIPTION	ACTION REQUIRED
Flashing "ARE"	Ambient temperature out of range	Reduce ambient temperature at controller, consult factory.
Flashing* "ERR"	Controller Ram violated, static discharge.	Controller must be reset to factory defaults. Consult factory for causes.
Steady "DEL"	Delivery probe fail.	Check probe connection or replace probe.
Steady "RET"	Return probe fail.	Check probe connection or replace probe.
Steady "L-R" "CHE"	4-20 mA input failed	Check polarity.

* Prior to Jan 1999 this was a flashing "DEL".

Fault Reset Procedure

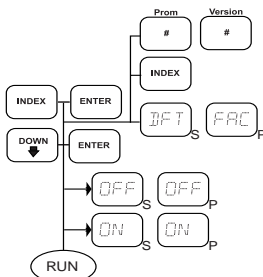
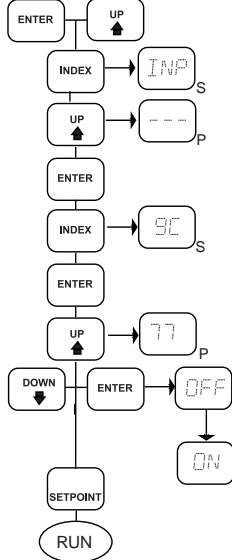
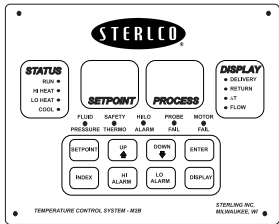

Reset Flashing "ARE"

- Enter Secure 4 menu by pressing **UP** and **ENTER** simultaneously for 3 seconds.
- **INDEX** to "INP"
- **UP** arrow until " --- " right display, press **ENTER**.
- **INDEX** to "9C" left display, press **ENTER**, 9 flashes.
- **UP** arrow until "77" in right display.
- Press **DOWN** and **ENTER** together to accept.
- Display will flash "OFF", then "ON" steady.
- Press **SET POINT** to exit to run.

Reload Factory Default

- Cycle control power to system Off and On.
- While M2B controller is performing the self test, simultaneously depress the **INDEX** and **ENTER** keypads together.
- Index until "DFT" and "FAC" appears in the display.
- Press the **DOWN** and **ENTER** keypads simultaneously to accept the factory default. Both displays will flash "OFF" then "ON" indicating re-boot is complete.
- The controller will automatically return to the run mode.

CAUTION: The M2B controller automatically defaults to a 250 °F (121.1 °C) set-stop limit, water temperature control unit (TCU) configuration. All special configurations. i.e. 4-20 MA scaling, will be lost. Please record menu variables before performing a factory default. If you have an oil TCU, the controller must be re-configured for a high temperature 550 °F (287.7 °C) set-stop limit.

High Temperature Oil Re-configuration

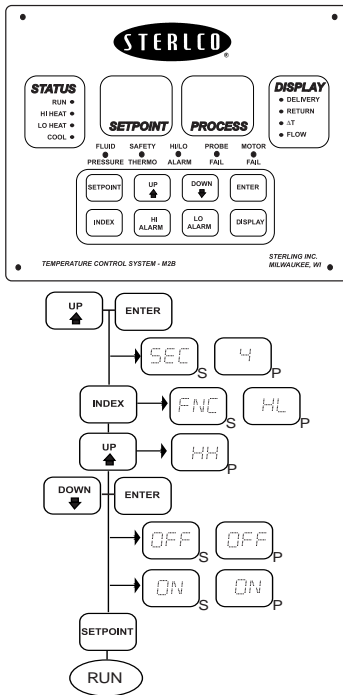

- Depress and hold the **UP** and **ENTER** keypads simultaneously for five (5) seconds to enter the secure menu.
- “SEC” will appear in the left display and “4” will appear in the right display.
- Depress the **INDEX** keypad until “FNC” appears in the left display and “HL” appears in the right display.
- Depress the **UP** arrow until “HH” appears in the right display.
- Depress the **DOWN** and **ENTER** keypads simultaneously to enter the parameter.
- Both the displays will flash “OFF” then “ON “ indicating the re-boot is complete.
- Depress the **SET POINT** keypad for short cut to the run mode, or, wait thirty (30) seconds for auto exit to run mode.



Field Calibration

All Sterlco controllers are pre-calibrated at the factory. Due to the design of our input circuitry, the factory calibration should be valid for the life of the instrument. In the event recalibration is warranted, Sterlco recommends verifying input calibration specifications every twelve (12) months. Follow the calibration procedures outlined in your controller manual.

Audit Temperature Inputs

To audit the temperature probes for accuracy the following procedure should be followed:

Materials supplied by user

1. Input Signal testing
 - a. Millivolt Runup (MVR) with an output impedance of 100 ohms or less. Accuracy should be $\pm 1\%$ or better.
 - b. Resistance decade box (RD) with an accuracy of $\pm 1\%$ or better.
 - c. Frequency counter with an accuracy of $\pm 1\%$ or better (0 to 2.5K mm. range).
 - d. Frequency generator capable of 50 to 200 Hz.
2. 4-1/2 Digit Digital Multimeter (DVM) with an accuracy of $\pm 0.05\%$ or better.
3. Ambient Temperature Indicator with an accuracy of $\pm 0.05\%$ or better.
4. Assortment of test leads.

Procedure

1. Power up Instrument and allow the M2B to warm up for 1 hour.
2. Hold the **ENTER** and **UP** Arrow keys for 5 seconds. The Menu will enter the SECURE MENU. The displays will read "SEC" and "4". If not, set the right display to "111", and press **ENTER**. The right display should blink and return to "4". Press the **INDEX** key until you see "FLO" and change it from "OFF" to "ON" and press **ENTER**. **INDEX** to "TCI" and change it from "OFF" to "ON" and press **ENTER**.
3. Press the **INDEX** key until you reach "INP". Use the **UP** and **DOWN** arrow keys until "--" shows in the right display. Press **ENTER**, and the two left digits of the left display will read "00" (See Figure-3). This is CAL 0. Place the RTD connector into slot D (see Figure-4). Adjust the decade box to 99.114 ohms. The calibration value of the M2B should be between 18CA to 22CF (in hexadecimal - see Table 1). Press the **ENTER** and **DOWN** arrow keys if the value is within the acceptable range.

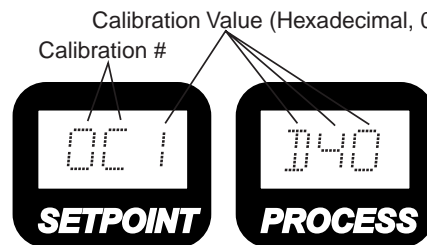
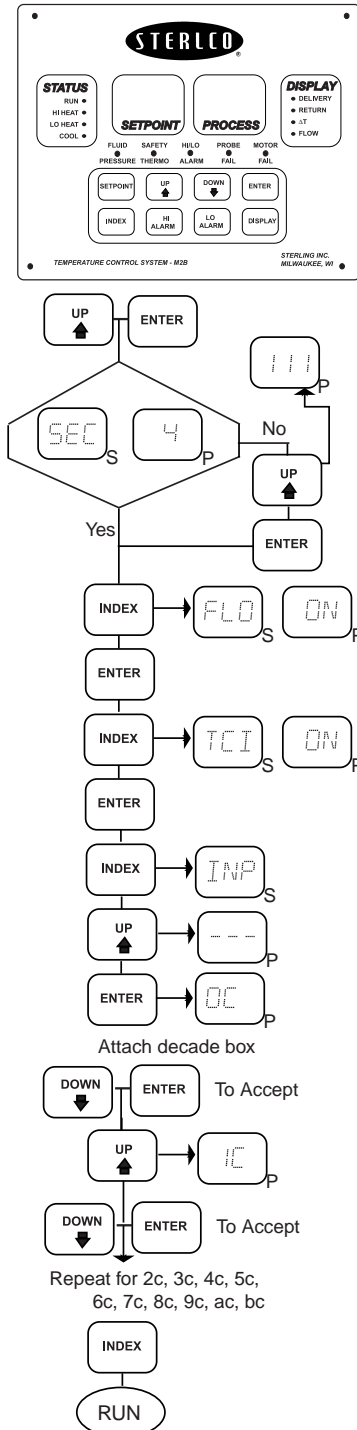

Figure-3

4. Use the **UP** arrow key to go to CAL 1 (“1”). Adjust the input to 2351.38 ohms. Make sure the calibration value is within the acceptable range (See Table 1) and press the **ENTER** and **DOWN** arrow keys simultaneously to accept.
5. Press the **UP** arrow key to go to CAL 2 (“2”). Move the RTD connector from D to E (See Figure-4) and adjust the Input down to 99.114 ohms. Make sure the calibration value is within the acceptable range (See Table 1) and press the **ENTER** and **DOWN** arrow keys simultaneously to accept.
6. Press the **UP** arrow key to go to CAL 3 (“3”). Adjust the input to 2351.38 ohms. Make sure the calibration value is within the acceptable range (see Table 1) and press the **ENTER** and **DOWN** arrow keys simultaneously to accept.

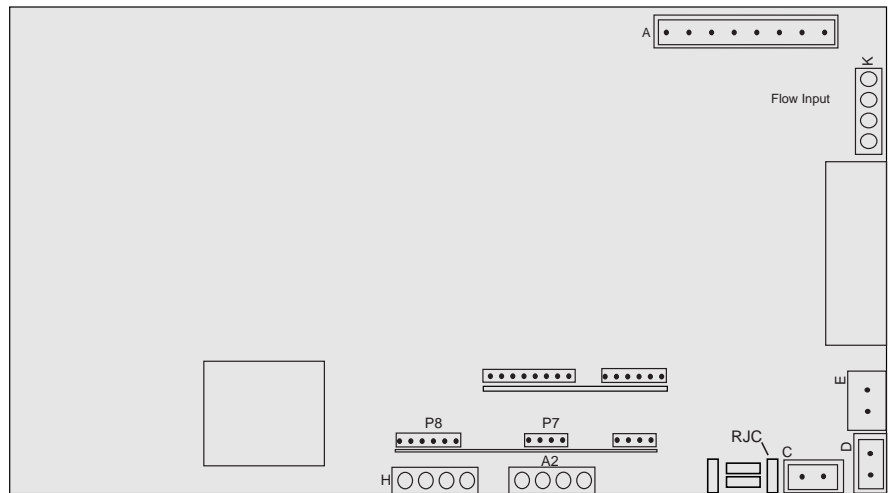

Figure-4

7. Press the **UP** arrow key to go to CAL 4 (“4”). Place the millivolt connection into connector C (see Figure-4). Adjust your millivolt signal to 4.663 mV. Make sure the calibration value is within the acceptable range (see Table 1) and press the **ENTER** and **DOWN** arrow keys simultaneously to accept. Repeat this step for Cal 5 (“5”), adjust the input for 73.953mV.
8. Press the **UP** arrow key to go to Cal 6 (“6”). Place the wires for the remote setpoint input into the last 2 terminals of connector A2. See Figure-4. (+ to terminal 3 and - to terminal 4). Adjust your input to 1.224 mA. Make sure the calibration value is within the acceptable range (see Table 1) and press the **ENTER** and **DOWN** arrow keys simultaneously to accept.
9. Press the **UP** arrow key to go to CAL 7 (“7”). Adjust the remote setpoint input to 19.721 mA. Make sure the calibration value is within the acceptable range (see Table 1) and press **ENTER** and **DOWN** arrow keys simultaneously to accept.



10. Press the **UP** arrow key to go to CAL 8 ("8C"). The left display should read between 5400 and 6400 (hexadecimal).
11. Press the **UP** arrow key to go to CAP 9 ("9C"). Press the **ENTER** key. The right display will blink. Observe the temperature from the Ambient Temperature Indicator. Press the **UP** and **DOWN** arrow keys until you reach the ambient temperature. Press the **ENTER** and **DOWN** arrow keys to retain (display will blink to indicate value is accepted).
12. Press the **UP** arrow key to go to CAL A ("AC"). Place load (1.5K ohm resistor) into terminals 1 and 3 of connector K, see Figure-4. Connect frequency generator and frequency counter across the load. Adjust the input to 50 Hz (41 Hz for 75 GPM). Make sure the calibration value is within the acceptable range (see Table 1) and press the **ENTER** and **DOWN** arrow keys simultaneously to accept.
13. Press the **UP** arrow key to go to CAL B ("BC"). Now adjust the input to 200 Hz (131.5 Hz for 75 GPM). Make sure the calibration value is within the acceptable range (see Table 1) and press the **ENTER** and **DOWN** arrow keys simultaneously to accept. Press the **INDEX** key to exit. The calibration is now complete.

Table-1

Input Type	Cal. #	Input Value	Calibration Value
RTD	0	99.114 ohms	18CA to 22CF
RTD	1	2351.38 ohms	8759 to B228
RTD	2	99.114 ohms	18CA to 33CF
RTD	3	2351.38 ohms	8759 to B228
TC	4	4.663 mV	18CA to 22CF
TC	5	73.953 mV	8759 to B228
Remote Input	6	1.224 mA	18CA to 22CF
Remote Input	7	19.721 mA	8759 to B228
Ambient	8	Ambient	5400 to 6400
Ambient	9	Ambient Temperature	
Flow (30 GPM)	A	50 Hz	18CA to 36D9
Flow (30 GPM)	B	200 Hz	6d48 to 9816
Flow (75 GPM)	A	41 Hz	
Flow (75 GPM)	B	137.5 Hz	



Electrical Specifications

Temperature Inputs

T/C's J, K, E, (Remote Sensing Only)

Input Type	Range
J:	-100 to 1600 °F (-73 to 871 °C)
K:	-200 to 2500 °F (-129 to 1371 °C)
E:	-100 to 1800 °F (-73 to 982 °C)

Impedance 3 Meg ohms min.

RTD's Pt1000 din 0.00385 $\Omega/\Omega/^\circ\text{C}$ Range -328 to 1607 °F (-200 to 875 °C)

Source current 200 μA

Flow Input

Min. sig. 100 mV peak to peak

Impedance 100k min.

20 to 250 Hz.

128 GPM (485 lpm) max.

Temperature/Flow input resolution

Low gain 2.1 μV

Signal Inputs (0.5mA @ 5Vdc Sense)

Phase Relay

Safety Thermo

Low Pressure

Remote Set point Current: 0-20mA across 600OHM

Max., isolated to 500Vac

Outputs

Relay: SPST, 1A @ 250 Vac resistive; 1A @ 250 Vac inductive

Pilot Duty Rating: 125VA

Hi/Lo Heat, Cool, Alarm, Purge, Pump, Vent (adjustable off to 5 min.)

SSR: 1A@250Vac, isolated to 1500 Vac

Hi/Lo Heat, Cool

Current: 0 to 20 mA across 600 ohms max., isolated to 500 Vac

Heat, Cool, Process Output

Communications: RS232, RS485, Half and Full Duplex

RS 485SPI Half Duplex Only

Accuracy Temperature

$\pm 0.25\%$ of span \pm least significant digit

Temperature Stability

4 $\mu\text{V}/^\circ\text{C}$ typical, 8 $\mu\text{V}/^\circ\text{C}$ maximum

Common Mode Rejection

140 db minimum at 60 Hz.

Approvals



Ambient Temperature Range

14 to 131 °F(-10 to 55 °C)

0 to 90% up to 40 °C non-condensing,

0 to 50% at 55 °C non-condensing

**Supply Requirements**

100 to 240 Vac, nominal, +10 to -15%, 50 to 400 Hz, single phase
132 to 240 Vdc, nominal, +10 to -20%

Power Consumption

5VA maximum
DC Supply: +5V @ 30mA

General Specifications**Dimensions**

Front Panel 5 1/2 x 9 inches (13.97 x 22.86 cm)
Depth 3 3/4 in. (8.89 cm)

Weight

20 oz. (622 g)

Displays and Indicators

(2) 3-Digit Red Displays 0.56" (1.42 cm)
Red LED's for alarm functions
Pressure, Thermo, Hi/Lo Temp, Probe Fail, Motor
Green LED's for status and display indication
Run, Hi/Lo Heat, Cool, Delivery, Return, Delta, Flow

Connectors

PCB Interconnects
T and B Jumpers
System Connectors
WAGO 231 Series or equal
Communication and Current Output Connectors
WAGO Screw Pressure Plate



Appendix A

Hard Keys

Set Point	Process		Heat Low	Heat High
SP1	###	Main Set Pt.	175	175
ALO	###	Alarm Low	-100	
AHI	###	Alarm High	200	

Home (Index Keys)

Set Point	Process		Heat Low	Heat High
SYS	On/OFF	System On or Off (Standby)	On	
Prg	run/HLd	note 1	Programmer Run/Hold	
ti	###	note 3	Program Segment Time remaining	
#ti	###	note 3	Program Segment Time	
#SP	###	note 3	Program Segment Set Point	
tun		Tune choice	PID	PID
	SLF	Self Tuning		
	Lrn	YES/No	Start Learn	
	dFa	OFF, 1 to 7	Damping factor 1=less, 7 = more ratio rate to reset	3 3
	Pid	Manual PID tuning		
	PbH	1 to 5000	Proportional Band 1 (deg or counts)	14 14
	PbC	1 to 5000	Proportional Band 2 (deg or counts)	20 10
	rES	0 to 999.9	Reset time in sec	1.5 1.5
	OFS	0 to 99.9	Manual reset value in percent	OFF OFF
	rtE	0 to 99.99	Rate time in minutes	0.05 0.05
	SLO	Slow response process		
	nor	Normal response process		
	FAS	Fast response process		
FPC	0 to 100	Fuzzy intensity in percent 0 = off Impact fuzzy logic has on process	50	50
Fbd	1 to 400	Fuzzy Band in deg. or counts = to PBH	14	14
FrC	0 to 99.9	Fuzzy rate of change in deg. or counts per second	2.5	2.5
PEA	###	Peak PV, ENTER to reset to present PV		
UAL	###	Valley PV, ENTER to reset to present PV		
2SP	###	Auxiliary Set Pt.	0	0
tc	###	Note 4	T/C Monitor Temp	
FAL	0 to 100	Note 4	Flow Alarm Low	0 0
FAH	0 to 100	Note 4	Flow Alarm High	100 100
AUt	OFF, 1 to 5	Auto vent cycle OFF, 1 to 5 min.	1.0	OFF
HiH	On/OFF/AUt	High Heat On/ Off/Auto	AUt	AUt



Secondary Menu (Up and Enter Keys)

Set Point	Process		Heat Low	Heat High
Unt	F/C	Degrees F or C	F	F
AL1	OFF/Lo/Hi/HL/Eut	Alarm (Off, Low, High, Hi.Lo, Event)	OFF	OFF
A1t	AbS/dE	Absolute or Deviation to SP1	dE	dE
A1r	OnF/HOL *	Alarm Reset, auto reset/manual reset	OnF	OnF
A1i	On/Off	Power Interrupt	OFF	OFF
A1H	On/OFF	Power inhibit, suspend alarm until PV enters non-alarm condition	On	On
A1S	CLS/OPE	Contact Closed/Open @ Alarm	CLS	CLS
A1L	O on/oFF	Lamp (on/off) contact closed	Oon	Oon
A1b	On/OFF	Alarm on Loop Break	OFF	OFF
Prg	On/OFF	Programmer ON/OFF (ramp/soak)	OFF	OFF
SEt	On/OFF	Prog, values available for viewing & changing	OFF	OFF
StA	On/OFF note 2	Status of Prog. in Home Position	OFF	OFF
SEC	1 S/6OS note 2	Prog. time base (1 or 60 sec.)	1-S	1-S
#ti	0 to 9999 note 2	Segment time	0	0
#SP	#### note 2	Segment Set Pt.	0	0
#A1	On/OFF note 2	Alarm 1 Event	OFF	OFF
#A2	On/OFF note 2	Alarm 2 Event	OFF	OFF
End	Hld/Oof/LoP/SPt note 2	Programmer End (Hold, Off, Loop, SP)	OFF	OFF
A2L	###	Alarm 2 Low		
A2H	###	Alarm 2 High		
Ato	On/OFF	Auto/Man	OFF	OFF
rUP	On/OFF	Anti-Reset windup	OFF	OFF
Pct	On/OFF	Percent Output in SV display	OFF	OFF
LPb	OFF, 1 to 9999	Loop Break time in sec.	OFF	OFF
POL	###	Process Output Low	0	0
POH	###	Process Output High	250	550
POS	InP/SP1	Process Output Source	InP	InP
rSL	### 4 mA = -62.5 0 mA = 0 20 mA = 250	Remote Set Pt. Low	0	0
rSH	### 250	Remote Set Pt High	250	550
rSP	On/OFF	Remote Set Pt On/OFF	OFF	OFF
L-r	LOC/rE	Comm Local/ Remote	LOC	LOC
Add	1 to 3FF	Comm Address Viewable Only	32	32

* manual reset by simultaneously pressing index & down keys for 5 seconds.



Secure Menu (Up and Enter - 5 seconds)

Set Point	Process		Water Temp. Control Unit Heat Low	Oil Temp. Control Unit Heat High
SEC	####	Security Code	4	4
FnC	HL/HH/L	Function (Lo/Hi heat Chiller)	HL	HL
Sto	0 to 100	Self Tune Offset Percent	0	0
InC	-500 to +500	Input Correction	0	0
Fil	OFF, 1 to 99	digital Filter value 0=off (electrical noise)	OFF	OFF
SP2	###	Second Set Pt (COOLING)	0	0
Pd2	On/OFF	Link the I and D terms to PB2	ON	ON
Art	OFF, 1 to 99.99	Approach Rate outside PB1	OFF	OFF
tci	On/OFF	T/C Monitor On/OFF	OFF	OFF
FLO	On/OFF	Flow Monitor On/OFF	OFF	OFF
FCY	###	Flow in FREQ.		
FSL	0 to 100	Flow Scale Low @ 25 Hz (CAL.)	6	6
FSH	0 to 255	Flow Scale High @ 225 Hz (CAL)	30	30
FLF	0 to 100	Flow Filter	2	2
SAF	On/OFF	Safety Thermo On/OFF	ON	ON
PrS	On/OFF	Pressure Input On/OFF	ON	ON
InP	J-/CA-/E-	T/C Input Type (J, K, E)	J	J
Int	OFF,0.1 to 540.0	Input Fault Timer (min.)	OFF	OFF
Ot1		Output 1 type		
	OnF	On/OFF		
	S1d	#### On/OFF differential		
	1 to 80t	Time proportioning cycle rate in sec.	20	20
	#PuL	1 to 7 Pulse curve value 1 = linear, 7 = most non-linear		
PrP	Voltage/Current proportional output			
Ot2		Output 2 type		
	OnF	ON/Off		
	S2d	#### On/Off differential		
	1 to 80	Time proportioning cycle rate in sec.	15	15
	#PuL	1 to 7 Pulse curve value 1 = linear, 7 = most non-linear		
PrP	Voltage/Current proportional output			
SEn	OFF<1 to 4000	Sensor rate of change (cnts or deg. per sec)	OFF	OFF
SCL	DEFAULTED	Scale low	0	0
SCH	DEFAULTED	Scale high	250	550
SPL	min - SCL	Set Pt. low limit	0	0
SPH	max- SCH	Set Pt. high limit	250	550
S1S	dir/rE	Direct or Reverse Acting	rE	rE
S1L	0 to 90	Output 1 low limit	0	0
S1H	10 to 102	Output 1 high limit	100	100



Set Point	Process		Water Temp. Control Unit Heat Low	Oil Temp. Control Unit Heat High
S1C	O on/off	Lamp (on/off) contact closed	Oon	Oon
S2t	AbS/dE	Absolute of Deviation to SP1	dE	dE
S2S	dir/rE	Direct or Reverse Acting	dir	dir
S2L	0 to 90	Output 1 low limit	0	0
S2H	10 to 102	Output 1 high limit	100	100
S2C	O on/oFF	Lamp (on/off) contact closed	Oon	Oon
AL2	OFF/Lo/Hi/HL/Eut	Alarm (Off. Low, High, Hi/Lo, Event)	OFF	OFF
A2t	AbS/dE	Absolute or Deviation to SP1	dE	dE
A2r	OnF/HOL	Alarm Reset (On/Off, Hold)	OnF	OnF
A2i	On/OFF	Power Interrupt	OFF	OFF
A2H	On/OFF	Power Inhibit	On	On
A2S	CLS/OPE	Contact Closed/Open @ Alarm	CLS	CLS
A2C	O on/oFF	Lamp (on/off) contact closed	Oon	Oon
A2b	On/OFF	Alarm on Loop Break	OFF	OFF
Add	1 to 3FF Note 4	Comm Address Hexadecimal (992/3)	32	32
nAt	OFF, 1 to 99 Note 4	No activity Timer Minutes	OFF	OFF
Bau	300-19.2 K Note 4	Comm baud rate	9.6	9.6

Note 1: Only present when Pro = On

Note 2: Only present when SEt = On

Note 3: Only present when StA = On

Note 4: Only present when the option is active

Appendix B

Mounting

The M2B requires a hole in the panel measuring 8 1/2 inches (21.59 cm) by 4 1/2 in. (11.43 cm) high (see Figure-5). Four mounting holes are spaced 7 in. (17.78 cm) horizontally, and 5 in. (12.7 cm) vertically in a rectangular layout. The mounting holes are 1/4 in. (6.35 mm) diameter and the bolts are size 10 or equivalent.

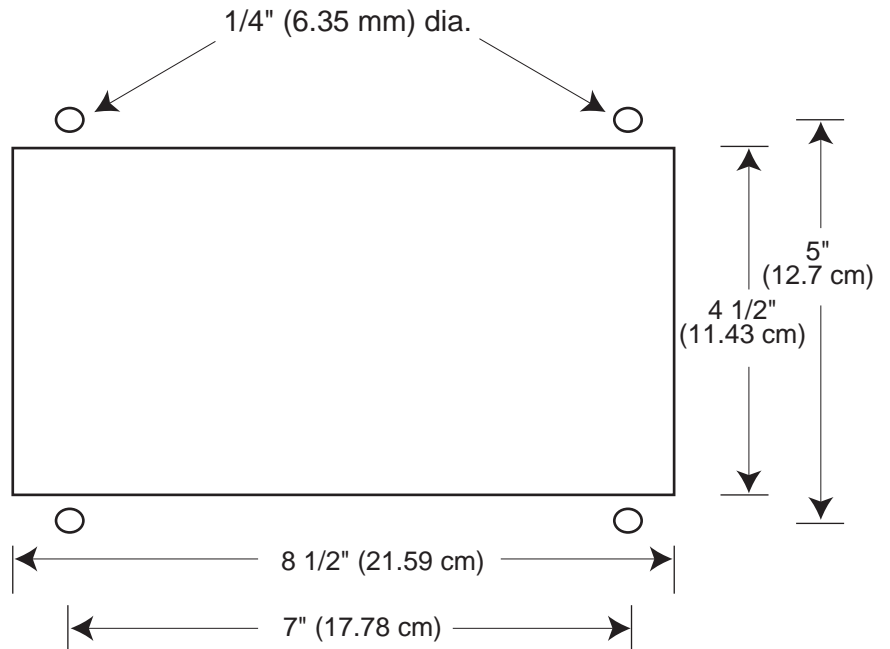

Figure-5 Mounting Dimensions.

Appendix C

Control Modes:

On-Off: Action takes place if any deviation from set point occurs. The output is either full on or full off depending on the direction of deviation. Because the on-off controller can cause rapid cycling around the set point, hysteresis (dead band) is built in to suppress fast control action.

Temp

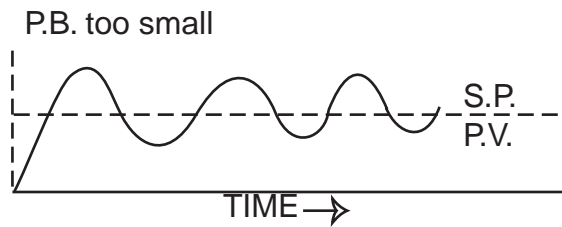

Proportional: Referred to as "P" or GAIN.

The controller switches the output based on the difference between the set point value and the process variable, and controls the output proportional to the deviation. This proportional action is active within a zone around the set point called the proportional band. The output becomes gradually smaller as the process variable nears the set point. Note that the process seldom reached the set point, but stabilizes at some deviation offset.

Temp

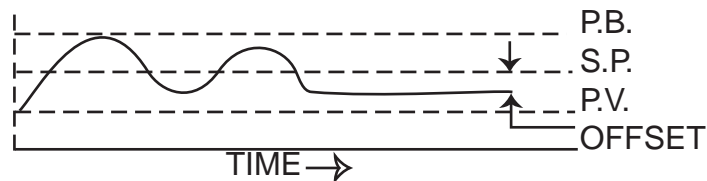

Integral: Referred to as "I" or RESET.

Expressed by integral time in seconds, the purpose of the integral action is to automatically compensate for any offset due to proportional action. The integral moves or resets the proportional band up or down to obtain set point. It is not intended to correct for process disturbances.

Temp

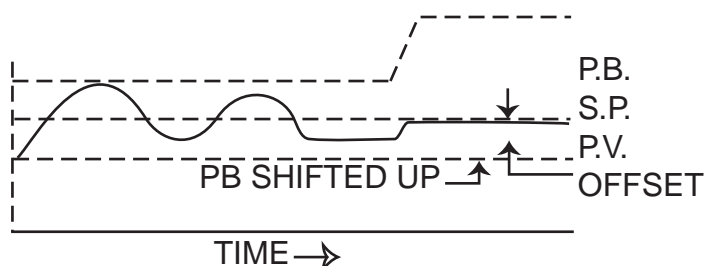

Derivative: Referred to as “D” or RATE.

Expressed as derivative time in seconds. The controller measures the rate of process increase or decrease and moves the proportional band to minimize overshoot. The change in the output is directly proportional to the rate of change in the process value.

Temp

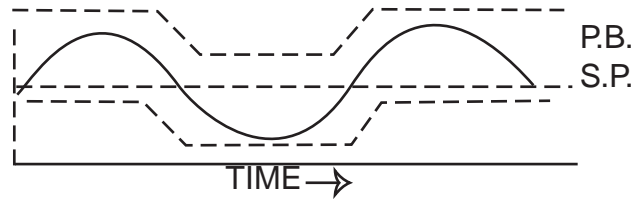

Anti-Reset Windup: This function inhibits the integral action until the process variable is within the proportional band, thus reducing overshoot on start-up.

Direct/Reverse Action: Direct action is used for cooling applications. The output of the controller increases with respect to an increase in the process value.
Reverse action is used for heating applications. The output of the controller decreases with respect to an increase in the process value.

Output

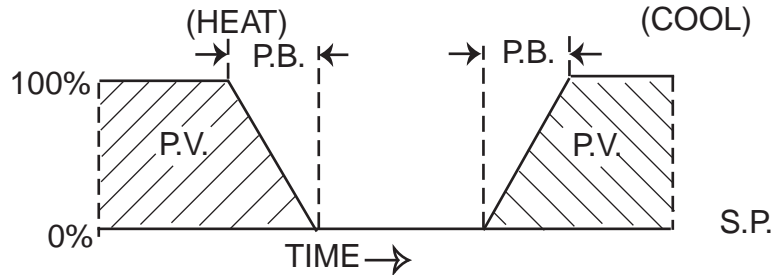



Adjustments:

Proportional

- 1) The lower the gain value (large proportional band), the less reactive the output becomes.

Temp

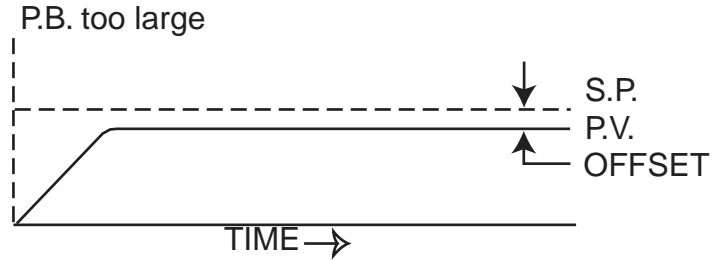

- 2) The larger the gain value (small proportional band) over responsive output, can lead to oscillation.

Temp

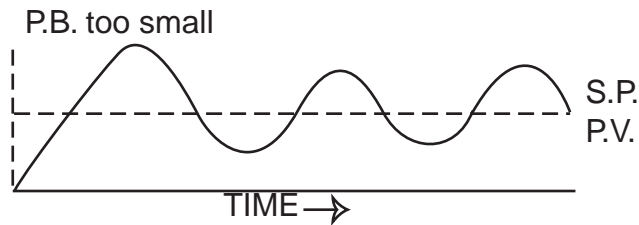

A proportional band which is correct approaches the set point as fast as possible while minimizing overshoot.

If a faster response is desired and process overshoot is not a problem, increase the gain value (over-damped system). If overshoot can't be tolerated, decrease the gain value (under-damped system.)

Integral

Integral action eliminates offset by adding to or subtracting from the output of the proportional action alone.

- 1) Short integral time means the controller corrects for offset quickly. If too short, the controller would react before the effects of previous output shifts, due to dead time or lag, are complete, could cause oscillation.

Temp

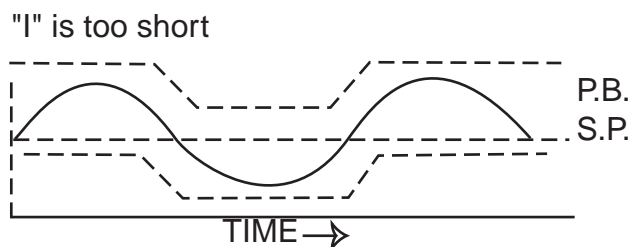

- 2) Long integral time means the controller corrects for offset over a long time. If the integral time is too long, the offset will remain inactive, causing slow response or sluggish control.

Temp

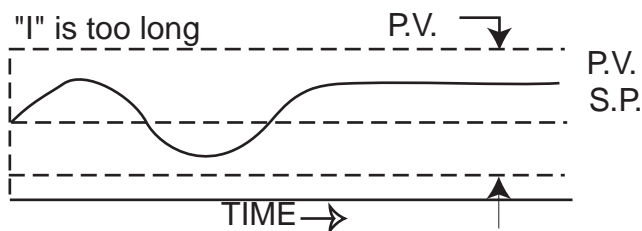

Derivative: Derivative time is the amount of anticipatory action needed to return a process back to set point. In the case of a process upset, proportional only or proportional-integral action alone can't react fast enough in returning a process back to set point without overshoot. Derivative action corrects for disturbances, providing sudden shifts in output which opposes the process disturbance.

Temp

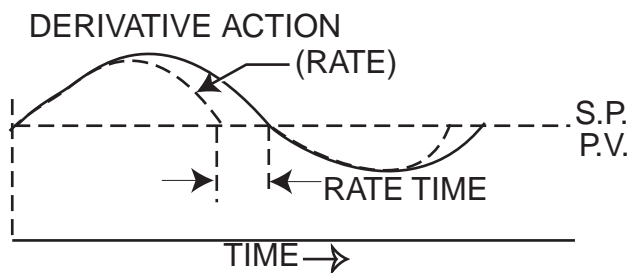

- 1) A short derivative time means little derivative action. If the derivative is too short, the controller would not react quickly to process disturbances and may not attain set point.
- 2) A long derivative time means more derivative action. If the derivative time is too large, the controller would react too dramatically to process disturbances creating rapid process oscillation (alternating heat and cool continuously).

PID COMPONENTS REACTING TO A LOAD CHANGE

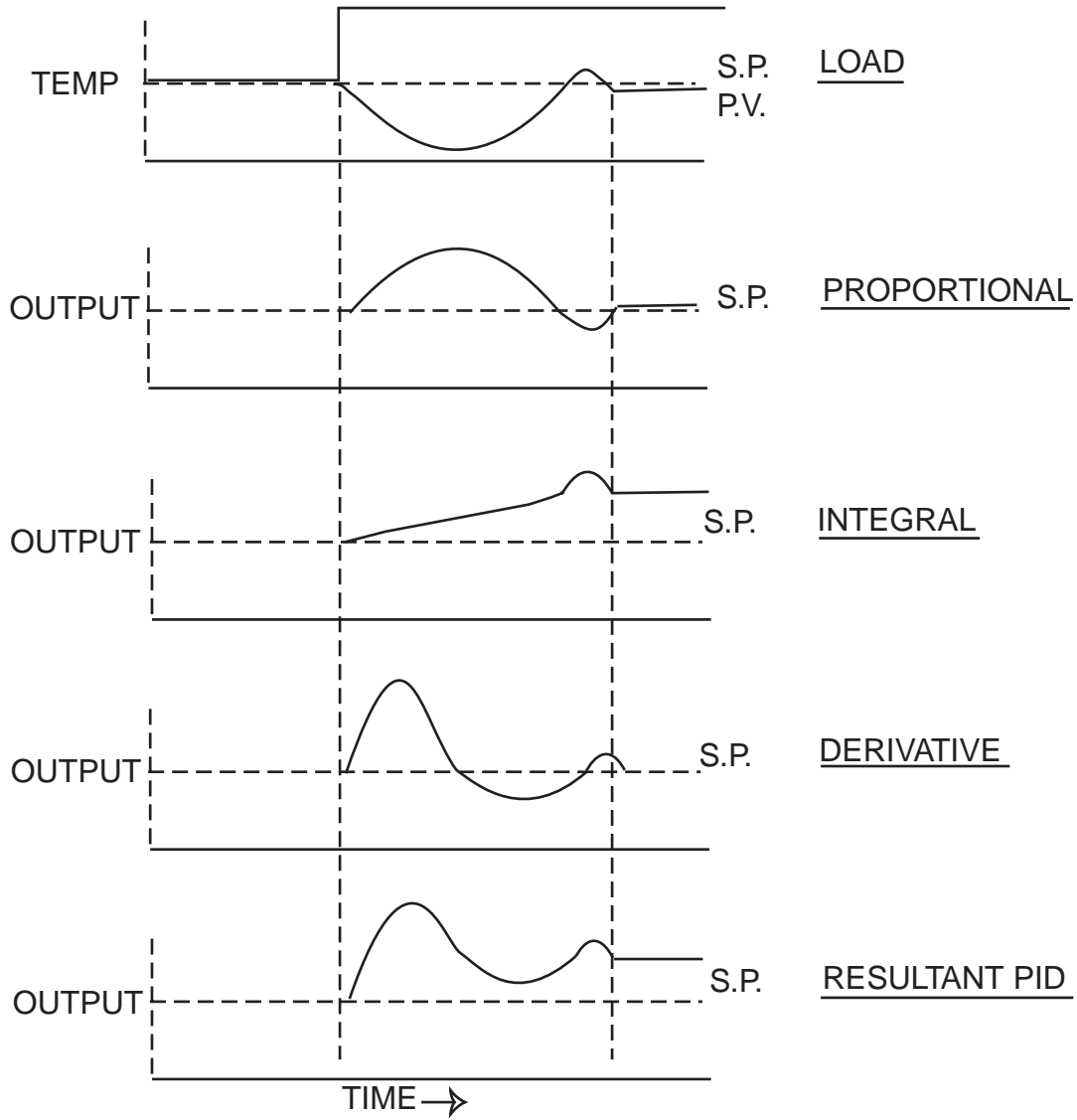



Appendix D

Drawing a Ramp/Soak Profile

Draw your ramp/soak profile on the record sheet below and fill in the associated information in the table below. This will give you a permanent record of your program and will assist you when entering the set point data.

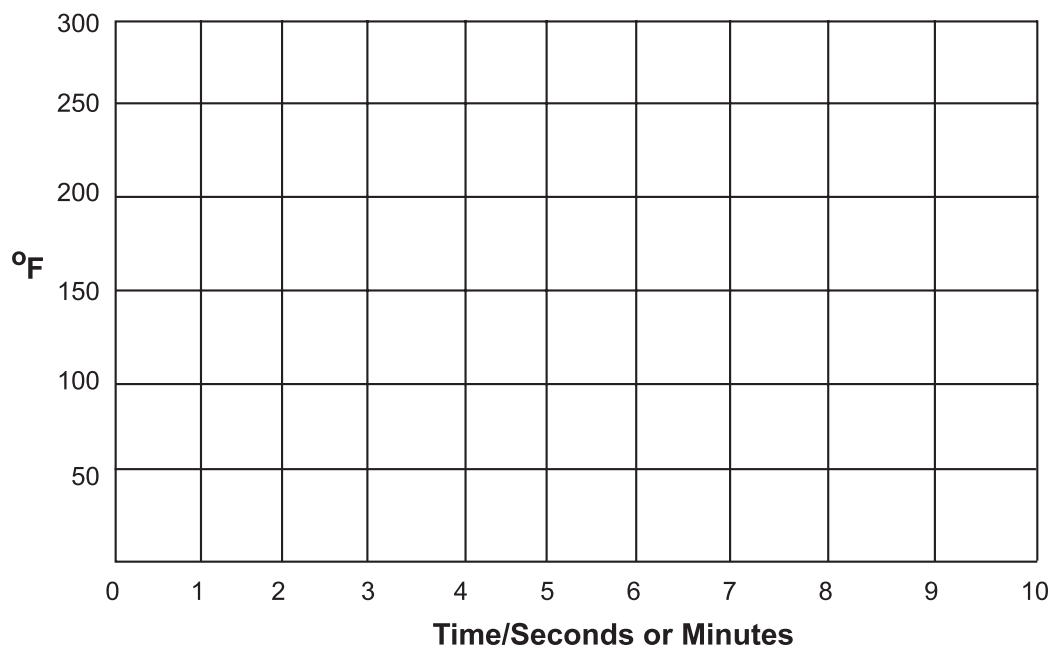

Prompt	Function	Segment	Value	Prompt	Function	Segment	Value
STRT SEG	Start Seg.			SEG7RAMP	Ramp Time	7	
END SEG	End Seg.			SEG8 SP	Soak SP	8	
RECYCLES	Number of Recycles			SEG8TIME	Soak Time	8	
SOAK DEV	Deviation Value			SEG9RAMP	Ramp Time	9	
SEG1RAMP	Ramp Time	1		SG10 SP	Soak SP	10	
SEG2 SP	Soak SP	2		SG10 TIME	Soak Time	10	
SEG2TIME	Soak Time	2		SG11 RAMP	Ramp Time	11	
SEG3RAMP	Ramp Time	3		SG12 SP	Soak SP	12	
SEG4 SP	Soak SP	4		SG12 TIME	Soak Time	12	
SEG4TIME	Soak Time	4		STATE	Program Controller State		
SEG5RAMP	Ramp Time	5		PROG END	Controller Status		
SEG6 SP	Soak SP	6		RAMP UNIT	Engr. Unit for Ramp		
SEG6TIME	Soak Time	6					



Appendix E

Glossary of Terms

Alarm A condition that exists if the process variable exceeds internally stored alarm setpoints. Those setpoints can be:

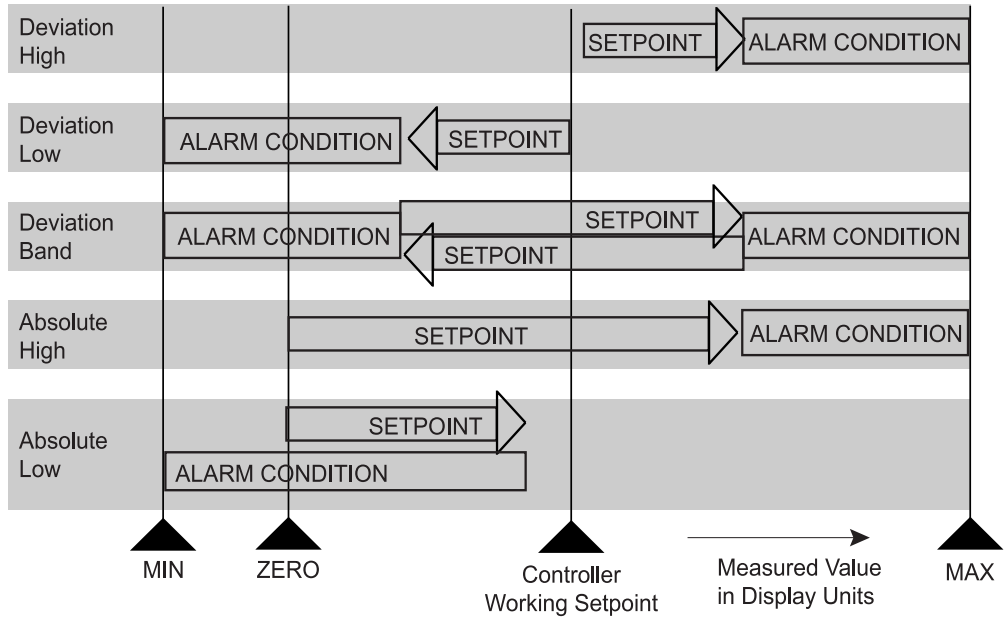

Alarm Inhibit Prevents low setpoint alarm activation during cold startup applications.

Auto/Manual Alternative control conditions that can be selected within the controller.

Manual - An open loop condition, in which the power to the process is manually set and not influenced by the sensor.

Auto-A closed loop condition, in which the power to the process is automatically computed and set by the sensor output relative to the setpoint.

Bias Allows the operator to compensate for any difference between sensor temperature and the point to be measured. The process display and setpoint will be offset by the value entered in the Bias parameter in the input menu. Example: Desired temperature is 150 degrees. Sensor is adjacent to heater and reads 50 degrees higher than the actual process temperature. Enter bias of -50. Enter setpoint of 150. Process will display 150 even though sensor will be measuring 200 degrees.

Cycle Time The period of time in which the controller's output completes an on-off cycle (proportional output type only). Example: Output type = mechanical relay; cycle time = 10 seconds; Output power = 50%; controller output = 5 seconds closed, 5 seconds open.



Deadband	In on/off temperature control, it is the band above or below the setpoint where there is no output action, It has the effect of moving the apparent setpoint.
Derivative (Rate)	Adjusts the controller gain quickly in response to load changes.
Derivative Action	Is normally used to give a fast response to changes in process value and to improve process stability. Alternatively derivative action may be configured to act on the error signal which is useful in ramping applications.
Direct Action	Control action such that the output increases as the process value increases.
Failsafe State	Designates the percentage of power output that the controller defaults to after it detects a loop break condition and after the loop break time has elapsed.
Filter (in Display Menu)	Changes the filtering speed for the process value display only. It does not affect control. This parameter is mainly used to slow down the flickering of the display when the decimal position chosen is greater than zero.
Filtering (in Input Menu)	Sets the time period over which the process value is averaged.
Hysteresis	In on/off temperature control, hysteresis represents the band where the output changes state from deactivated to activated. It prevents chattering around the setpoint and prevents rapid output cycling.
Hold	The freezing of a running program, in time, for the duration of the condition.
Integral (Automatic Reset)	Slowly adjusts the position of the proportional band (range of power output) to eliminate offset error.
Local/Remote	Alternative selections of the working setpoint. Either a value stored within the controller (local) or an analog signal brought into the controllers rear terminal (remote).
Loop Break	A condition where the input is not changing or responding properly to the output action. This could be caused by a thermocouple or input failure, or a heater or load failure.
Loop Break Time	The time interval from when the controller detects a loop break condition and the initiation of the failsafe state.
Manual Reset	An adjustment that moves the proportional band up or down by a fixed percentage so that more or less power is applied at setpoint. It is used to eliminate offset error.



On/Off Output Type	<p>In a heating application, the controller applies 100% output power if the process temperature is below the setpoint and 0% at the setpoint. For a cooling application, the controller applies 100% output power if the process temperature is above the setpoint and 0% output power at the setpoint. There are only two output states: fully on and fully off.</p> <p><i>Applications for On/Off Control:</i> 1. When temperature oscillation is acceptable. 2. When constant cycling of mechanical devices is prohibited (compressors, blowers, etc.). 3. Under-powered processes.</p>
Output Low Limit %	Prohibits the controller's output from going below the specified percentage.
Output High Limit %	Prohibits the controller's output from going above the specified percentage.
Output Relay	Relays that are normally driven by the alarm output condition but can, as an alternative, be driven by segments of the program.
PID Output Type (Proportional - Integral-Derivative)	<p>The controller modulates output power by adjusting the output power percentage within a proportional band. Power is proportionally reduced as the process temperature gets closer to the setpoint temperature. PID control helps reduce overshoot on start-up, enhances stability, and compensates for process lag. The PID parameters are automatically calculated for a particular application during the autotune process.</p> <p><i>Applications for PID Control:</i> 1. Where process temperature lags exist. 2. When load changes are present. 3. When overshoot is prohibited. 4. When very accurate control is required.</p>
Program	A preset profile of the controller setpoint made up of ramps and soaks, together with the sequence of state of the output relays.
Proportional Action	The lower the gain value (large proportional band) the less reactive the output becomes proportionally to the error between setpoint and process value. The proportional band is the range of process value over which this linear gain action occurs before the output saturates at maximum or minimum. This is often expressed as a percentage of the instrument span. The gain of the instrument varies inversely as the proportional band increases. (see Manual Reset)
Proportional Band	The band (expressed in degrees of temperature) in which the controller modulates its power percentage.
Ramp	One segment of a program where the controller setpoint moves from one level to another linearly during a fixed period of time.
Reset	An action which returns a completed or running program to the start condition, i.e. controlling SP1, SP2, or remote SP.
Reverse Action	Control action such that the output decreases as the process value increases.
Run	An action which starts a program running or restarts it from a hold condition.



- Self Tune** A facility which, when enabled, performs a number of 'on' and 'off' sequences of the controller output measuring the influence this has on the measured value. From these results the value of proportional band, integral time and derivative time plus, under certain circumstances, cut back low, cut back high, heat cycle, cool cycle time and relative cool gain, for optimum control, are calculated and written into the commissioning mnemonics.
- Soak** A time entered into a program during which the setpoint remains constant.
- Temperature Lag** The product of thermal resistance and thermal capacity. Also defined as delay of the transmission of heat from the controlled element to the sensor caused by thermal mass of the process material and/or process container, or the distance between the control element and the sensor.
- Upper Setpoint Limit** Prohibits users from adjusting the setpoint higher than the selected value.

