



# SYSTEM ONE

## Parts List



GBC IS AN ACCO BRANDS COMPANY

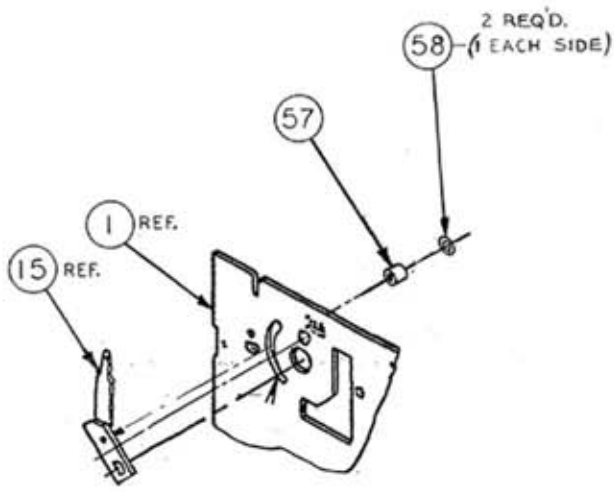

DETAIL "A"

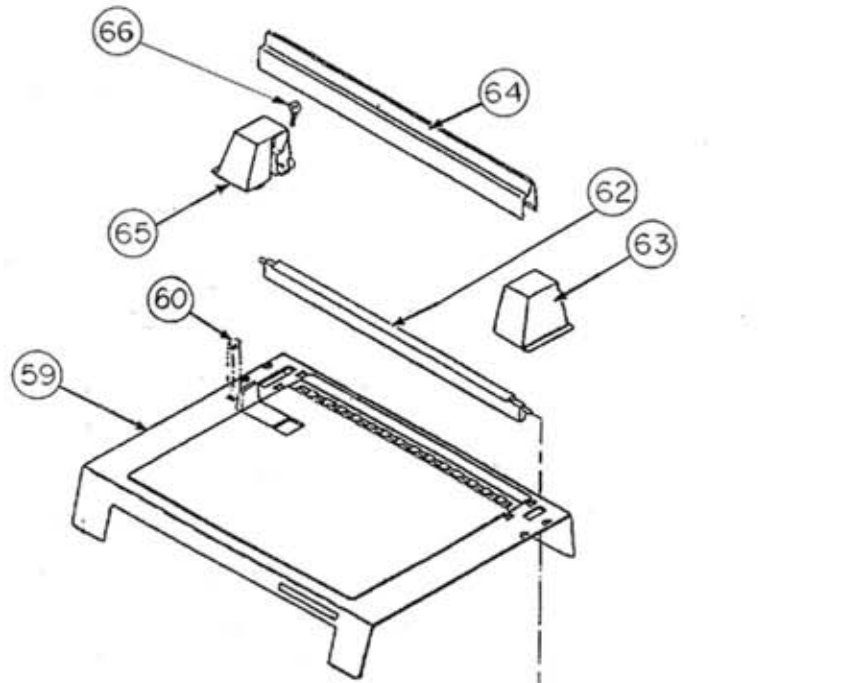

SEE DETAIL "A"

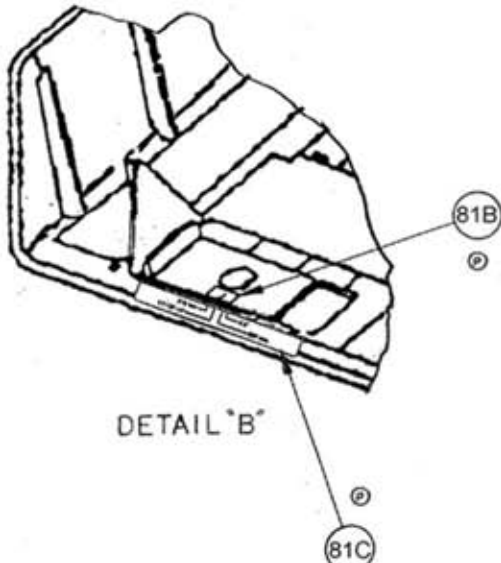
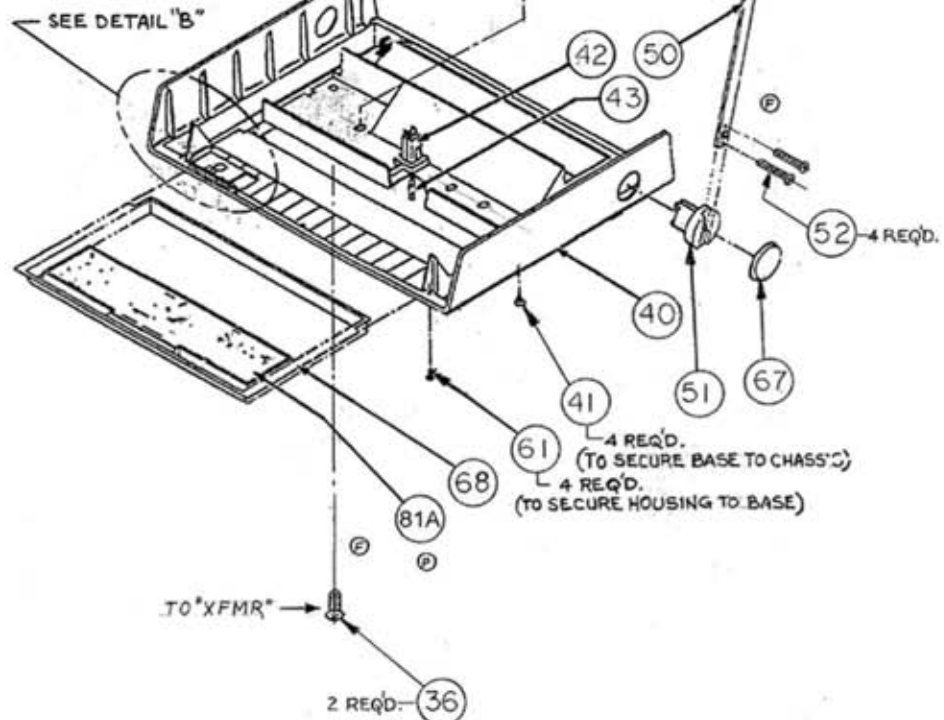
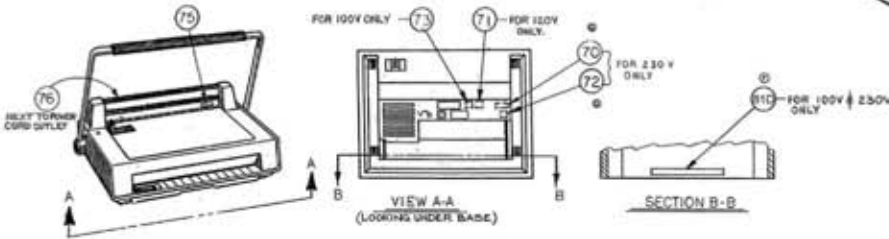
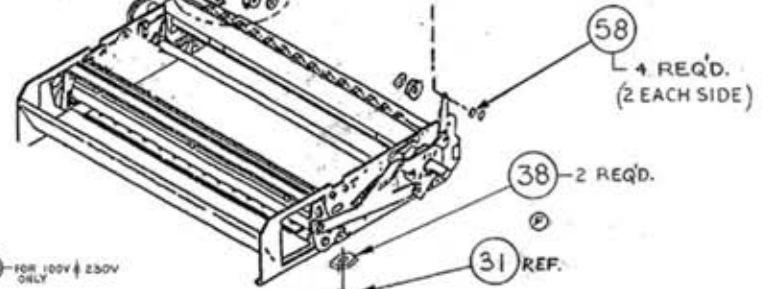

DETAIL "B"

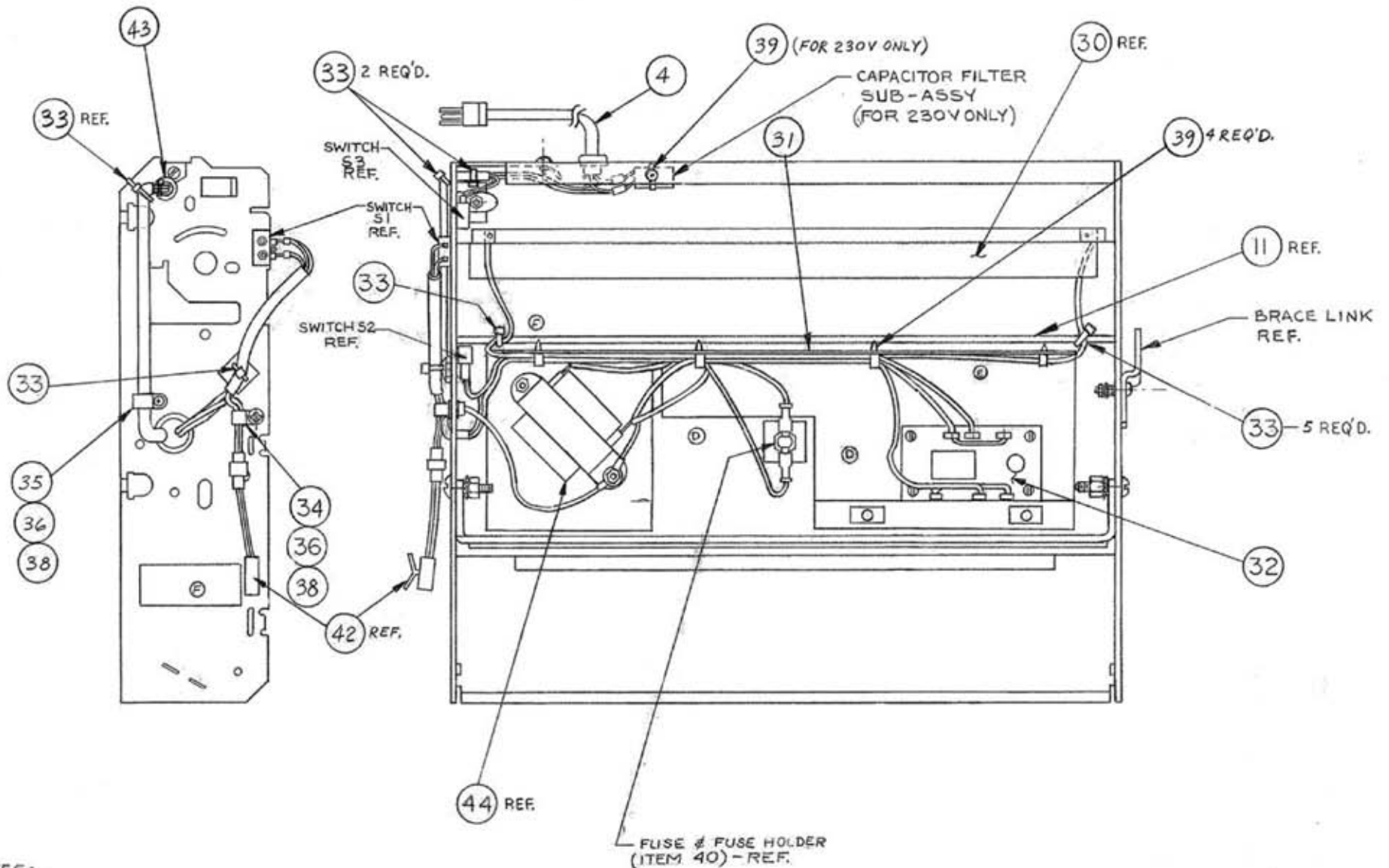

**NOTES:**

1. CONNECT TIME RELAY TO WIRE HARNESS ACCORDING TO WIRING DIAGRAM.  
ATTACH TIME RELAY TO PLATE GUARD USING PCB STAND OFF.
2. GROUND X-FORMER USING ONE OF IT'S MOUNTING SCREW, GROUNDING WIRE  
(PART OF WIRE HARNESS) AND 8-32 PN HEAD SCREW WITH NUT TO LEFT SIDE PLATE.

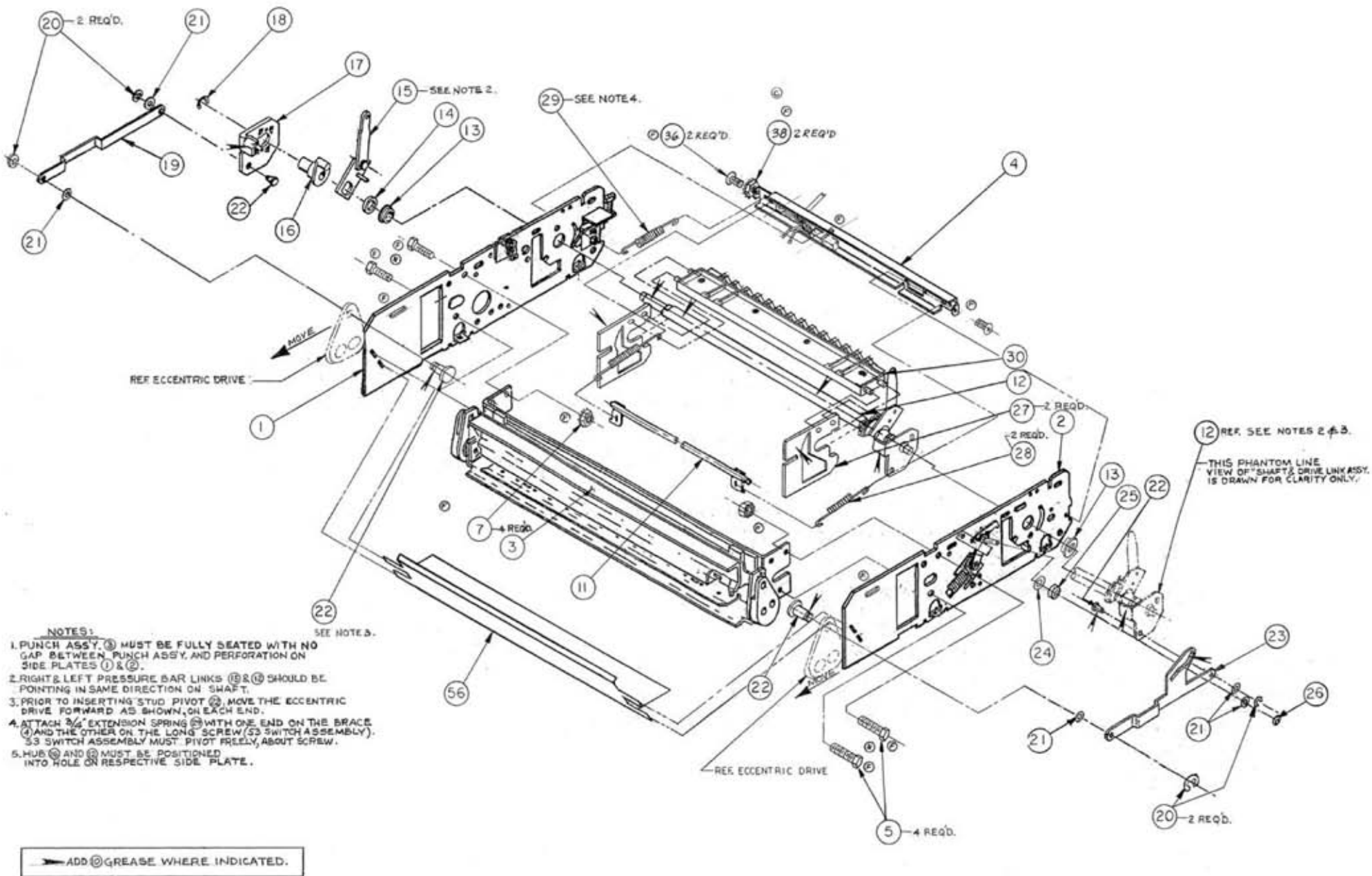

**SYSTEM ONE - FINAL ASSY.**



ITEM	PART DESCRIPTION	QTY	PART NUMBER					
			COMMON	7704951-GRAY SB-JAPAN,100V	7704901-GRAY SB-DOM,120 V	7704891-GRAY VB-INTL,230V	7704941-GRAY SB-INTL,230V	7704881-GRAY VB-DOM,120 V
1	SIDE PLATE & SWITCHES ASY,LH	1	9783569					
2	SIDE PLATE ASSY,RH	1	9781896					
3	PUNCH HOUSING ASSY.COMPL	1		9778711	9778711	9778708	9778711	9778708
4	BRACE& CORD ASSY	1		9783572	9783571	9783570	9783570	9783571
5	SCREW HEX HEAD 1/4-20 X 5/8	4	1951904					
6	NOT USED							
7	NUT HEX 1/4-20 WASHER(KEPS)	4	1926805					
8	NOT USED							
9	NOT USED							
10	GREASE LUBRICATING	A/R	1961503					
11	TIMING SHAFT - SYS 1	1	7704873					
12	SHAFT & DRIVE LINK ASY,RHS-SYS1	1	9783573					
13	BEARING	2	9776609					
14	SPACER	1	1925220					
15	LINK ASY,L.H,P.BAR-SYS 1	1	9780020					
16	HUB	1	9778198					
17	LINK DRIVE LH	1	9778450					
18	RING RETAINING	1	1930544					
19	LINK BIND	1	9781050					
20	RETAINING RING	4	1930510					
21	WASHER FLAT PALSTIC	5	1925208					
22	STUD PIVOT	4	9779351					
23	ACTUATOR	1	9781049					
24	SPRING WASHER	1	1926310					
25	ROLLER CUTTER ARM	1	9779084					
26	E-RING,185 DIA	1	1930530					
27	PLATE DRIVE	2	9778732					
28	SPRING DRIVE	2	9779269					
29	SPRING EXTENSION 3/4"	1	9779271					
30	HEATER ASSY	1		9777072	977072	9776678	9777072	9776678
31	WIRE HARNESS	1	9784036					
32	RELAY 2FROMC ADJ DELAY	1		9784027	9784027	9784028	9784028	9784027
33	TIE WRAP	5	1932121					
34	CABLE CLAMP 1/8 DIA	1	1931015					

ITEM	PART DESCRIPTION	QTY	PART NUMBER					
			COMMON	7704951-GRAY SB-JAPAN,100V	7704901-GRAY SB-DOM,120 V	7704891-GRAY VB-INTL,230V	7704941-GRAY SB-INTL,230V	7704881-GRAY VB-DOM,120 V
35	CABLE CLAMP 5/16 DIA	1	1931013					
36	SCREW PH PAN HD 8-32 X1/2	6	1902809					
37	NOT USED							
38	NUT HEX 8-32 WASHER(KEPS)	6	1926802					
39	TIE WRAP (SNAP)	4	1932123					
40	BASE ASSY.COMPLETE,SYS 1	1		7704874	7704874	7704874	7704874	7704874
41	SCR PAN HD SHT MET 1/4-14X3/48	4	1905017					
42	LIGHT INDICATOR ASSY	1		9784036	9784036	9784037	9784037	9784036
43	OPEN/CLOSE BUSHING,437 DIA	1	1953205					
44	XFMR HEATER POWER	1		9784041	9784039	9784040	9784040	9784039
45	NOT USED							
46	NOT USED							
47	NOT USED							
48	NOT USED							
49	NOT USED							
50	HANDLE ASSY,SYS 1	1		7704882	7704882	7704882	7704882	7704882
51	COUPLING DRIVE	2	9776796					
52	SCREW PH PAN HD 10-32 X2	4	1911136					
53	NOT USED							
54	NOT USED							
55	NOT USED							
56	DEFLECTOR SYSTEM ONE	1	9781272					
57	BUSHING DRIVE PLATE STOP	2	9779908					
58	RING RETAINING	6	1932502					
59	HOUSING ASSY COMPL,SYS 1	1		7707942	7704942	7704875	7704942	7704875
60	LENS INDICATOR,LIGHT	1	9778433					
61	SCREW PHIL FLT HD 8X1/2	4	1904806					
62	PRESSURE BAR ASSY. SYS 1	1		7704876	7704876	7704876	7704876	7704876
63	TURRET RH SYS ONE	1		7704943	7704943	7704877	7704943	7704877
64	BACKSTOP SYSTEM ONE	1		7704945	7704945	7704879	7704945	7704879
65	TURRET LH SYS ONE	1		7704944	7704944	7704878	7704944	7704878
66	SCR #2X3/8 PH PAN HD TYPE B	1	1907835					
67	CAP,HANDLE SYS 1	2		7704884	7704884	7704884	7704884	7704884
68	TRAY WASTER SYSTEM ONE	1		7704885	7704885	7704885	7704885	7704885

ITEM	PART DESCRIPTION	QTY	PART NUMBER					
			COMMON	7704951-GRAY SB-JAPAN,100V	7704901-GRAY SB-DOM,120 V	7704891-GRAY VB-INTL,230V	7704941-GRAY SB-INTL,230V	7704881-GRAY VB-DOM,120 V
69	NOT USED							
70	TUV PRODUCT SERVICE GS LABEL	1				1128417	1128417	
71	CSA NRTL/C LABEL	1			6009413			6009413
72	LBL CE MARK,.875 IN	1				6009178	6009178	
73	LABEL DENTORI SYS ONE	1		9781698				
74	NOT USED	1						
75	LABEL CAUTION HOT SURFACE INTL	1		1154236	9781618	9781617	9781617	9781618
76	CAUTION LABEL	1		6009000	6009000	6009001	6009001	6009000
77	OVERSIZE BLK EQUIPMENT TESTING	2		1132850	1132850	9741170	1132850	9741170
78	1X11 BLK EQUIPMENT TESTING	5		1132830	1132830	9741010	1132830	9741010
79	A4 TEST STOCK PAPER	70	1128331					
80	NOT USED							
81	LABEL KIT	1		7705127	7705127	7705128	7705127	7705128
81A	LABEL, WASTE TRAY	1	9781744					
81B	DECAL EDGE PUNCH SYS 1,2,3	1	9781469					
81C	DECAL PUNCH SYSTEM	1		7704946	7704946	7704886	7704946	7704886
81D	DECAL OPERATING TIME	1		7704966		7704966	7704966	

# HOUSING ASSY COMPLETE

**NOTES:**

1. STRIP COVER, ITEM 2, SHOULD BE INSTALLED TO HOUSING, ITEM 1, WITH HEAT STAKE.

2. ALLOW 24 HOURS DRYING TIME FOR THE ASSEMBLY OF PIN LOCATING, ITEM 3

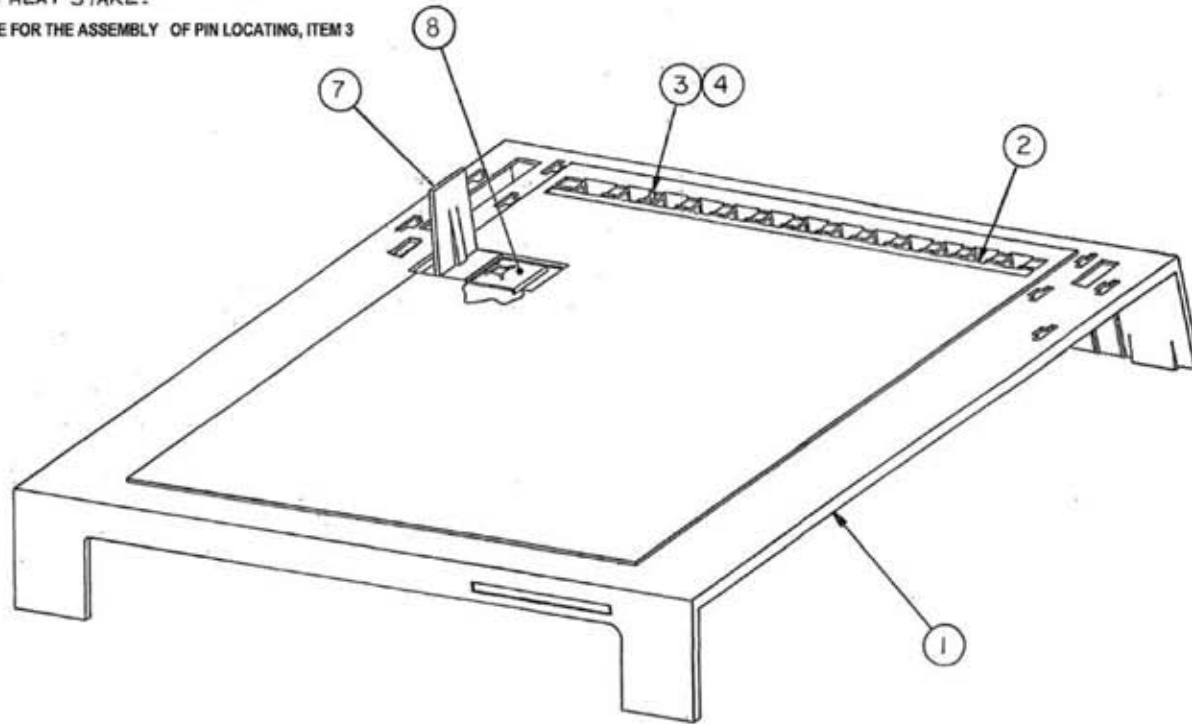

NO	DESCRIPTION	QTY.	COMMON	7704942 SYS1 SB GRAY	9781485 SUREBIND	9781296 VELORIND	7704875 SYS1 VB GRAY
ITEM				PART NUMBER			(C)
8	SPRING PAPER GUIDE	1	9779954				
7	GUIDE PAPER BIND SYS 1	1		7704902	7704902	9781277	7704902
6							
5							
4	LOCTITE 454	A/R	1960569				
3	PIN LOCATING	1	9778682				
2	STRIP COVER	1		9777400	9777400	9779358	9779358
1	HOUSING SYSTEM ONE ASY	1		7704909	7704907	7704906	7704908

**NOTES:**

- 1 THE DRAWING IS FOR ASSEMBLY GUIDELINE ONLY. PLEASE REVIEW INDIVIDUAL PARTS DRAWING FOR DETAILS.
- 2 INSERT SPRING PAPER GUIDE, ITEM 6, ABOUT 1/16" DEEP ON SQUARE STUD BENEATH GUIDE PAPER PUNCH, ITEM 5.
- 3 ASSY ITEM 13 WITH ITEM 2, THAN ATTACH ITEM 2 TO BASE (ITEM 1) USING 2 SPEED NUTS (ITEM12)
- 4 ITEM 8 IS PART OF THE SYSTEM 1 VELOBIND & SYSTEM 1 SUREBIND LABEL KITS PART NUMBERS 7705127 AND 7705128

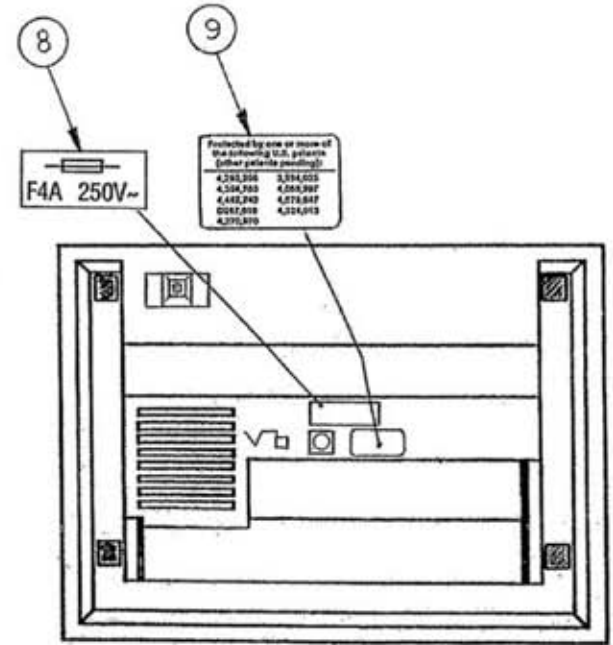
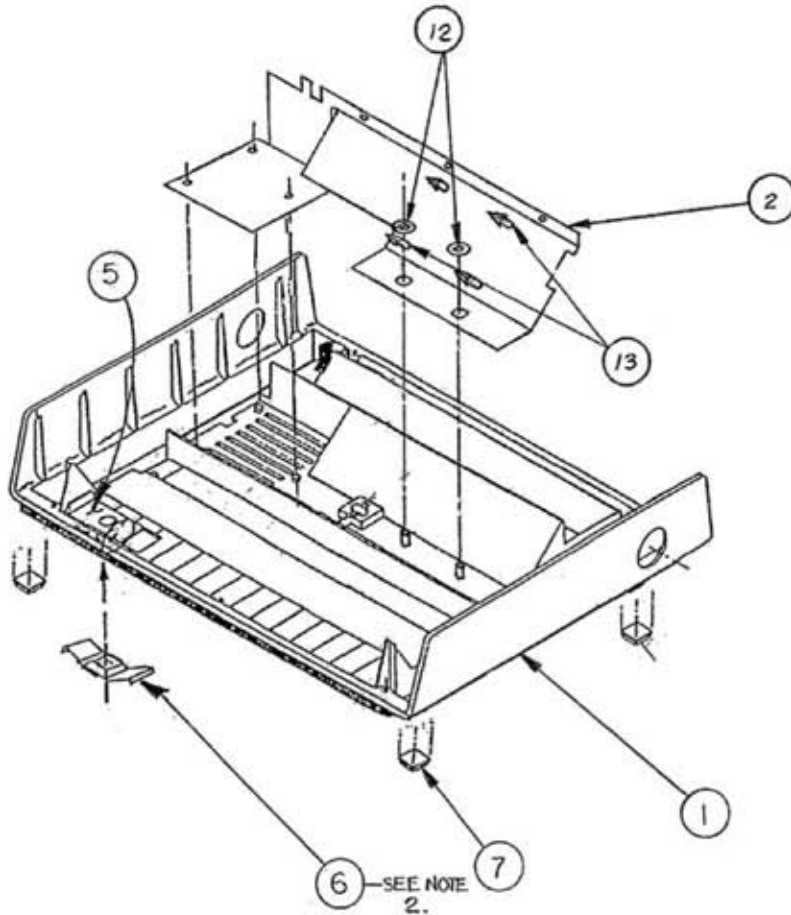

**BASE ASSY.COMPLEATE - SYS 1 - GRAY**

13	1951015	REVERSE LOCKING PCB SUPPORT 5/8"	4
12	1928906	NUT SPEED .5G DIA.	2
11	1970125	FUSE - 250V x 4A	1
10	1132343	FUSE HOLDER	1
9	6009400	PATENT LABEL	1
8	1963914	FUSE LABEL	1
7	1954504	FOOT RUBBER BLACK	4
6	9776954	SPRING PAPER GUIDE	1
5	7704895	GUIDE PAPER PUNCH SYS I	1
4	1960507	ADHESIVE	A/R
3	9776595	DEFLECTOR PLASTIC	1
2	9783896	PLATE GUARD SYSTEM ONE	1
1	7704895	BASE SYSTEM ONE	1
ITEM NO	PART NO	DESCRIPTION	QTY.

## PRESSURE BAR ASSEMBLY - SYS 1 - GRAY

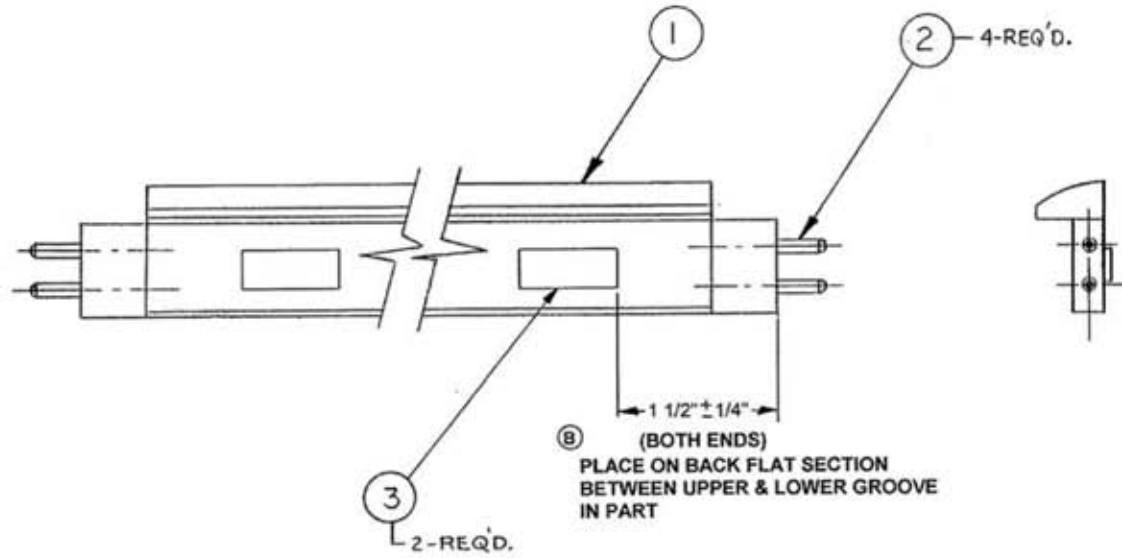

**NOTES**

1. ITEM 3 IS APART OF SYS1 SURE BIND AND VELOBIND LABEL KITS P/N'S 77015127 AND 7705128

3	9781498	SPACER WEAR PAD	2	
2	9776972	PIN, KNURLED	4	
1	7704894	PRESSURE BAR, GRAY	1	
ITEM NO.	PART NO.	DESCRIPTION	QTY.	ZONE

## HANDLE ASSEMBLY - SYS 1 - GRAY

### NOTES:

1. CLEAN MATING SURFACES PRIOR TO ASSEMBLY. ASSEMBLE GRIP (ITEM 3) TO HANDLE (ITEM 2). APPLY ADHESIVE (ITEM 1), INTO RECESSED SLOTS AT INSIDE REAR OF CAVITY TO BOTH GRIPS.

2. NO GAPS SHOULD BE VISIBLE BETWEEN GRIP HANDLES.

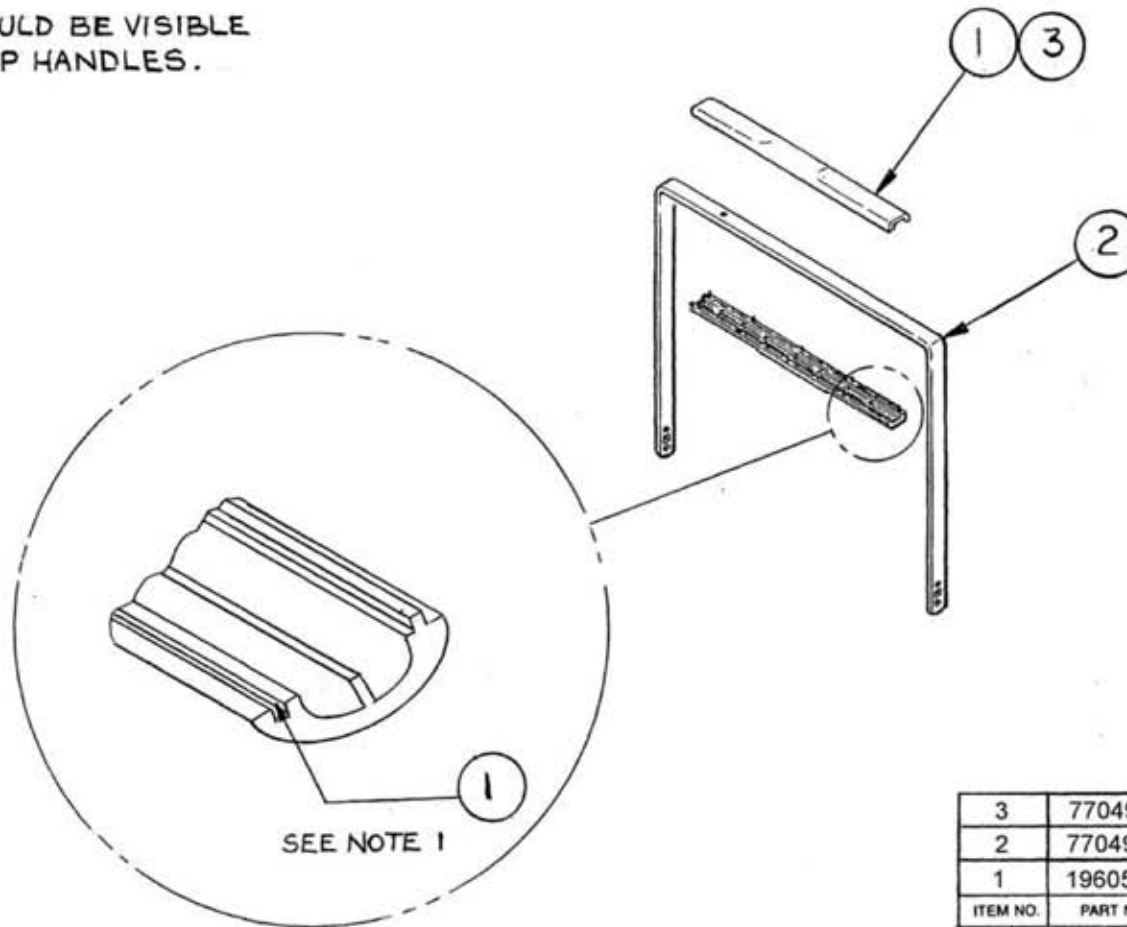

3	7704903	GRIP HANDLE SYS 1	2	
2	7704904	HANDLE PAINTED SYS 1	1	
1	1960506	ADHESIVE SICOMET	0.01	
ITEM NO.	PART NO.	DESCRIPTION	QTY.	ZONE

CROSS REF  
VB # 2400853-01

## SIDE PLATE(R.H)- SUB ASSY SYS ONE

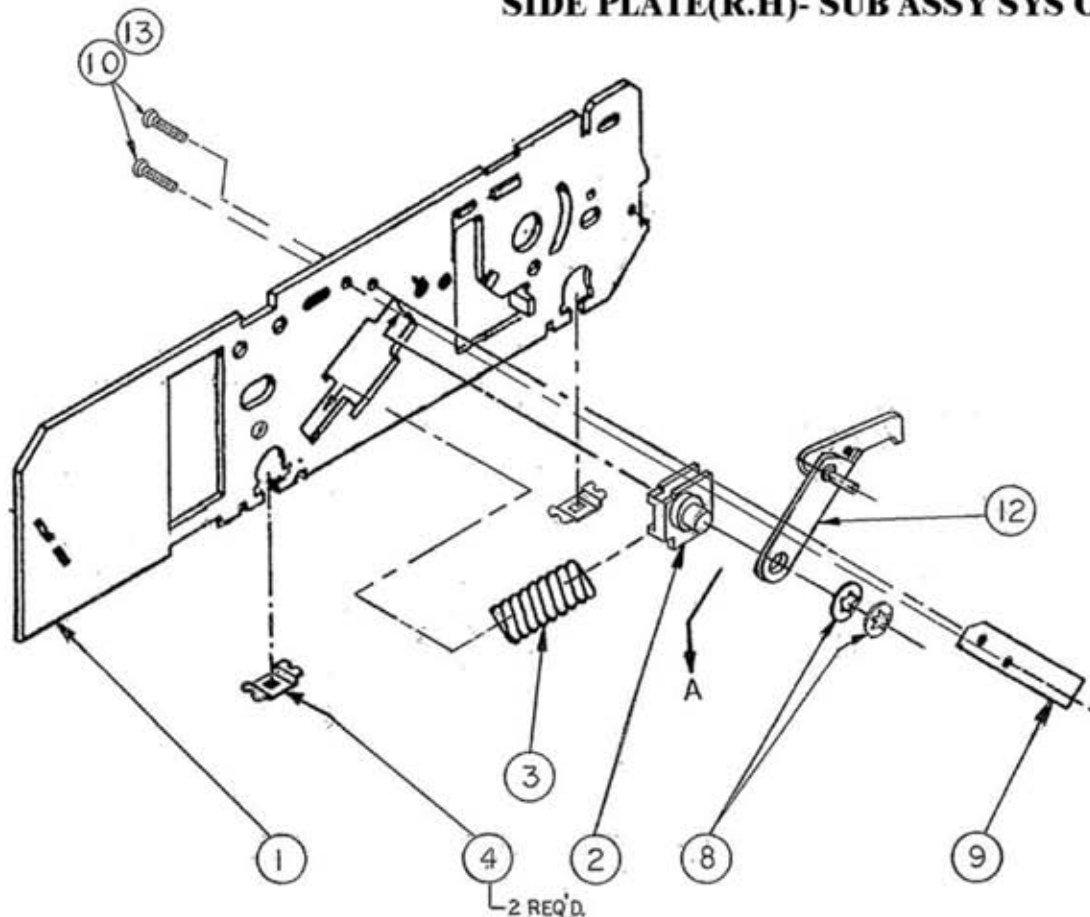

### NOTES:

1. ITEM (7)- PAWL ,MUST ROTATE FREELY IN THE FULL SWING RANGE IN BOTH DIRECTIONS BY ITS OWN WEIGHT.
2. RING STAKED PIN MUST WITHSTAND A 200 LB. FORCE APPLIED PARALLEL TO AXIS OF PIN.

SIDE PLATE (R.H) - SUB ASSY. PARTS LIST			
ITEM NO	PART NO	DESCRIPTION	QTY
1	9784035	SIDE PLATE RH	1
2	9776665	BLOCK PILLOW	1
3	9779270	SPRING COMPRESSION 2-1/2"	1
4	1928031	NUT SPEED 1/4-14	2
5	9781871	PIN DRIVE	1
6	9781868	LINK PAWL	1
7	9781872	PAWL	1
8	1931301	NUT SPEED .312 DIA	2
9	9781892	BRACE SYS 1	1
10	1907321	SCREW 8-32 X3/8 HEX HEAD	2
11			
12	1961532	GREASE WITH TEFLON	0.01
13	1960524	LOCTITE 242	0.01

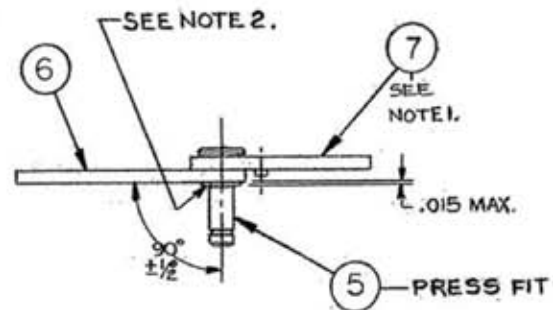

VIEW A-A

PAWL ASS'Y. (REF. ASSY. PART NO. 9778773)

# SIDE PLATE (L.H) SWITCH ASSEMBLY - SYS 1

## NOTES:

- 1 THE DRAWING IS FOR ASSEMBLY GUIDELINE ONLY. PLEASE REVIEW INDIVIDUAL PARTS DRAWING FOR DETAILS.
- 2 ADJUST THE SET SCREW, ITEM 14, DOWN ENOUGH TO HAVE THE FLANGE OF THE SWITCH BRACKET, ITEM 13, PARALLEL TO THE FLANGE ON THE SIDE PLATE, ITEM 1.
- 3 ADJUST SWITCH S1, ITEM 6, UNTIL SWITCH CLICKS WHEN SWITCH ACTUATOR FALLS BELOW FLANGE ON L.H. SIDE PLATE, ITEM 1.
- 4 USE ADHESIVE, ITEM 16, TO SECURE NUT, ITEM 15, TO SCREW, ITEM 14. VISUALLY INSPECT THE SET SCREW TO ASSURE THERE IS A NYLON INSERT ALONG THE LENGTH OF SCREW.

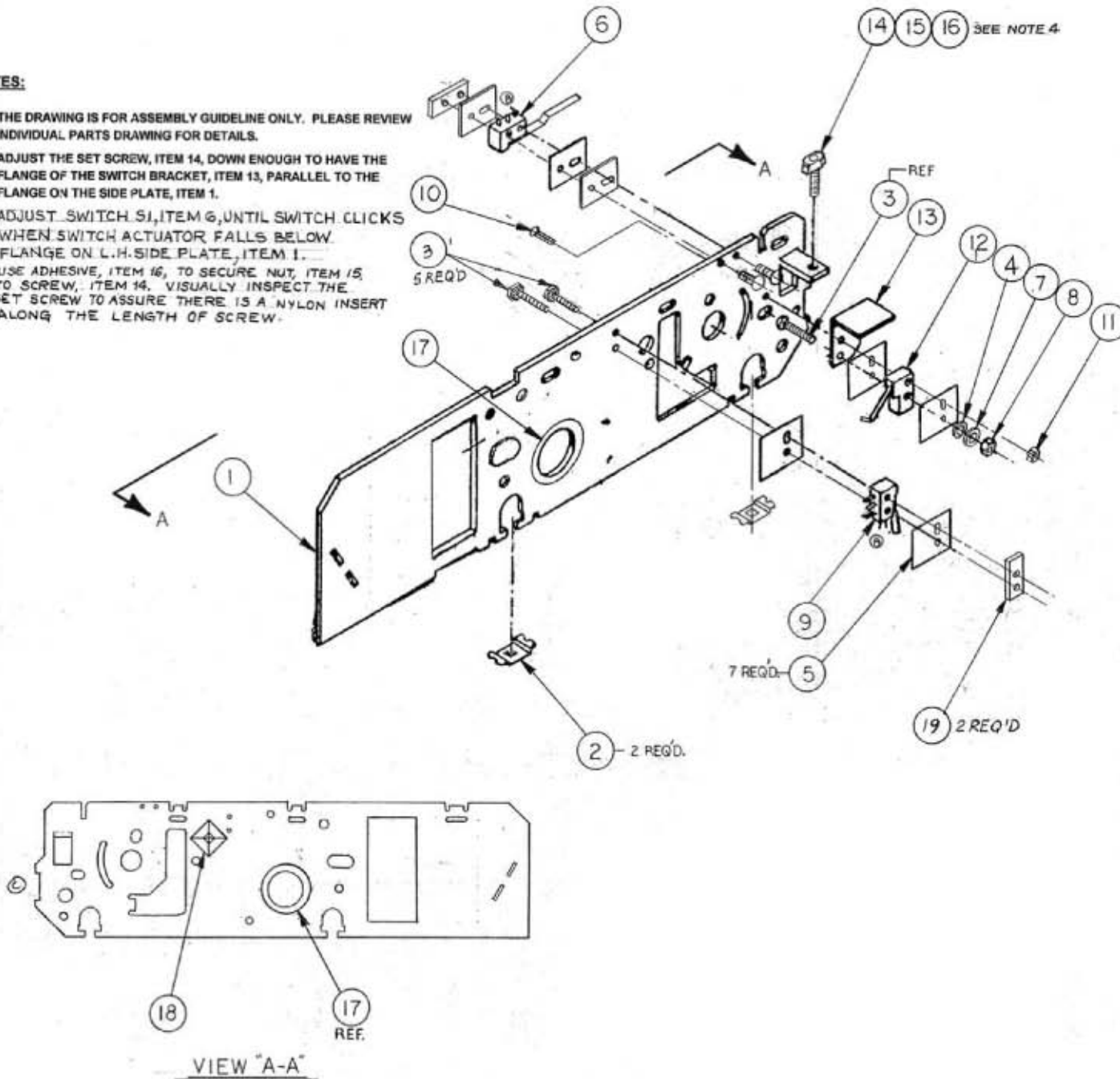

ITEM NO	PART NO	DESCRIPTION	QTY.
19	9778618	2-56 NUT PLATE	2
18	1931049	MOUNT WIRE HARNESS	1
17	1953201	SNAP BUSHING 1.00	1
16	1960512	ADHESIVE	AR
15	1926701	NUT HEX 8-32	1
14	1900022	SCREW SOC SET SELFLK 8-32X7/8	1
13	9776682	BRACKET SWITCH	1
12	9781085	SW SNAP ACTION SPDT S3	1
11	1927401	NUT HEX 2-56 SELF LOCKING	1
10	1902634	SCREW FLT HD PH 2-56X5/8	1
9	9781242	SWITCH SNAP ACTION SPDT S2	1
8	1926714	NUT HEX 2-56	1
7	1925120	WASHER FLAT #2	1
6	9781310	SWITCH SNAP ACTION S1	1
5	9783651	INSULATOR SWITCH	7
4	1925805	WASHER INTERNAL LOCK #2	1
3	1911184	SCREW SAMS PN PH 2-56 X 3/4	5
2	1928031	NUT SPEED 1/4-14	2
1	9784034	SIDE PLATE LH	1

NOTE:

1.-USE TOOL & ARBOR PRESS TO STAKE PIN.

REFER TO P/N 9780019 DWG FOR LINK ASSY, R.H. PR. BAR (MADE OF ITEM 3, 4, 5, & 6)

ITEM 5 MUST ROTATE FREELY IN THE FULL SWING RANGE IN BOTH DIRECTIONS BY ITS OWN WEIGHT. ITEM 4 CONNECTING PIN HEAD, SHOULD FACE TOWARDS RATCHET, 2.

2.-TURN HUB 7 SO THAT IT IS LOCKED WITH R.H.DRIVE LINK, ITEM 8.

3.- POSITION RATCHET 10 TOOTH, ITEM 2 WITH ROUNDED EDGES FACING R.H.DRIVE LINK, ITEM 8.

4.- ▲ LUBRICATE WITH GREASE, ITEM 10 WHEREVER MARKED.

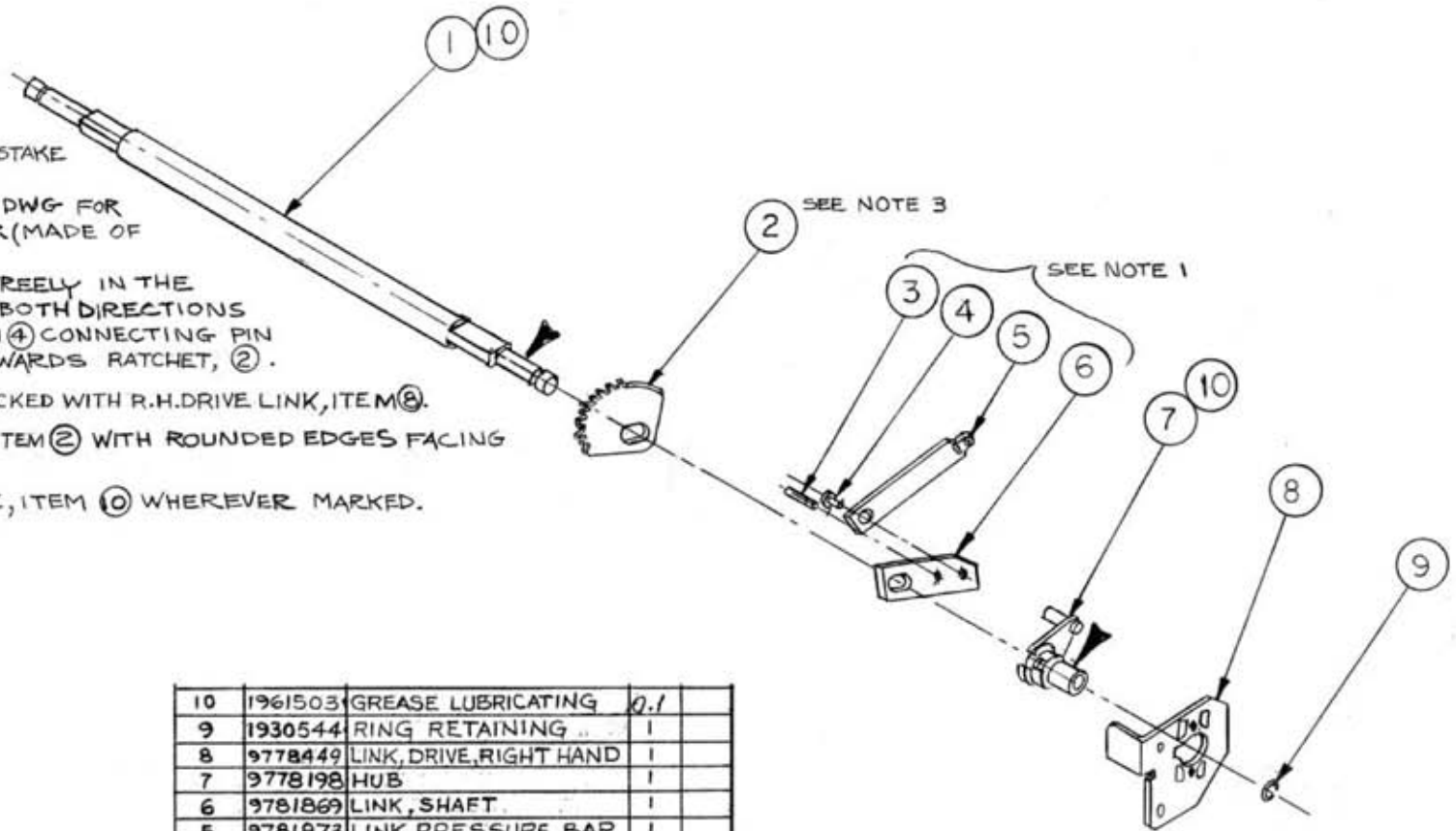

10	1961503	GREASE LUBRICATING	0.1	
9	1930544	RING RETAINING	1	
8	9778449	LINK, DRIVE, RIGHT HAND	1	
7	9778198	HUB	1	
6	9781869	LINK, SHAFT	1	
5	9781873	LINK PRESSURE BAR	1	
4	9781870	PIN CONNECTING	1	
3	1931542	PIN GROOVE .125 DIA X 1.00	1	
2	9779086	RATCHET 10 TOOTH	1	
1	9779233	SHAFT	1	
ITEM NO.	PART NO.	DESCRIPTION	QTY.	ZONE

**SHAFT & DRIVE LINK ASSY. (R.H.S) - SYSTEM ONE**

# BRACE & POWER CORD ASSY.

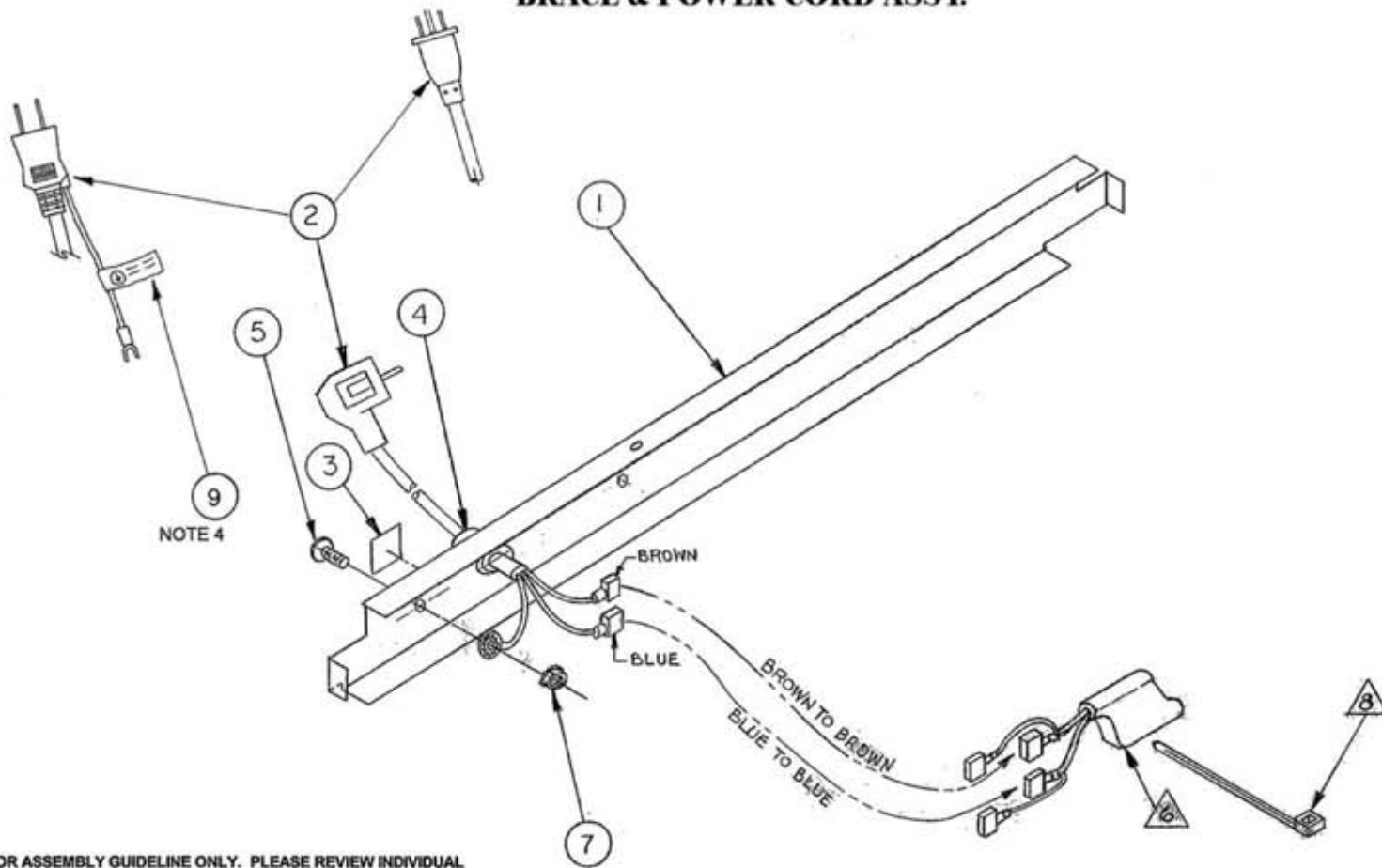

## NOTES:

- 1 THE DRAWING IS FOR ASSEMBLY GUIDELINE ONLY. PLEASE REVIEW INDIVIDUAL PARTS DRAWING FOR DETAILS.
- 2 ITEMS MARKED  $\Delta$  ARE USED IN 230 VOLT ONLY FOR CAPACITOR FILTER ASSEMBLY MOUNTING.
- 3 CAPACITOR FILTER ASSEMBLY INSULATION & MOUNTING (230 VOLT ONLY):  
WRAP WIRE TIE, ITEM 8, AROUND INSULATED CAPACITOR AND FASTEN IT IN BRACE.
- 4 ONLY THE JAPANESE CORD REQUIRES A GROUND WIRE AND GROUND LABEL.

NO	DESCRIPTION	QTY.	COMMON	9783572 100V	9783571 120V	9783570 230V
9	GROUND LABEL, JAPAN	1		6009438	---	---
		1		---	---	9784008
		1		---	---	1926003
		1		---	---	1932123
		1		---	---	1931050
		1		---	---	9781827
		1		---	---	1932123
8	TIE WRAP	1		---	---	1932123
7	NUT & WASHER (KEPS) 8-32	1	1926802			
6	CAPACITOR FILTER ASSY	1				9784004
5	SCREW PH PAN HD 8-32X1/2		1902809	Qty=1	Qty=1	Qty=1
4	BUSHING STRAIN RELIEF	1	1952407			
3	LABEL-GROUND SYMBOL	1	1128416			
2	LINE CORD SET	1		6200066	9781346	9781347
1	BRACE	1	9776683			
			COMMON	9783572	9783571	9783570
				100V	120V	230V
				PART NUMBER		

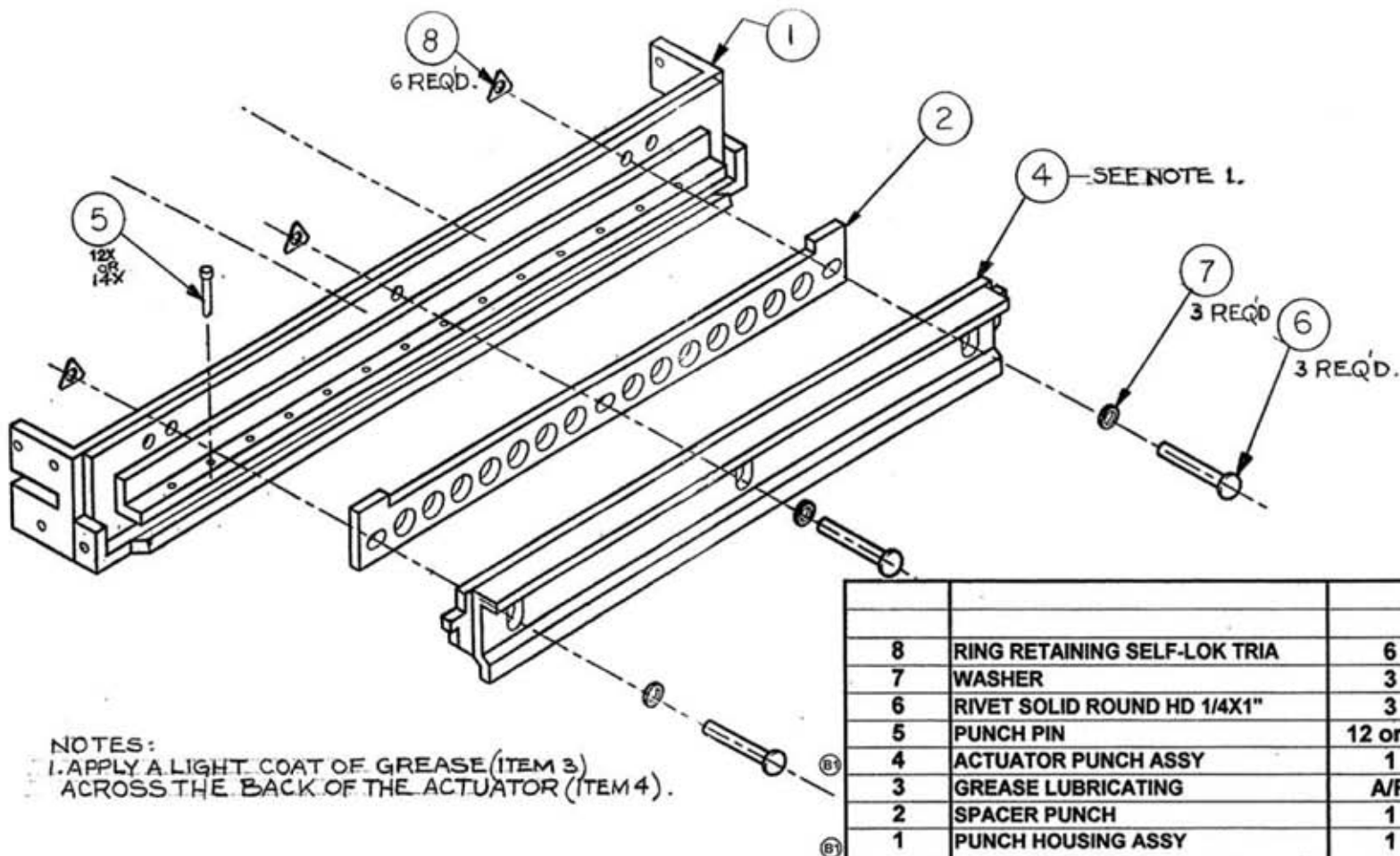

NOTES:  
 1. APPLY A LIGHT COAT OF GREASE (ITEM 3)  
 ACROSS THE BACK OF THE ACTUATOR (ITEM 4).

8	RING RETAINING SELF-LOK TRIA	6	1929105		
7	WASHER	3	1925218		
6	RIVET SOLID ROUND HD 1/4X1"	3	1930011		
5	PUNCH PIN	12 or 14	9778684	Qty=12	Qty=14
4	ACTUATOR PUNCH ASSY	1		9781390	9776365
3	GREASE LUBRICATING	A/R	1961503		
2	SPACER PUNCH	1	9779250		
1	PUNCH HOUSING ASSY	1		9777425	9778194
NO			COMMON	9781814	9781029
ITEM	DESCRIPTION	QTY.		<u>SUREBIND</u>	<u>VELOBIND</u>
				PART NUMBER	

**PUNCH HOUSING ASSY.COMPOSITE**

# PUNCH HOUSING ASSY - SYS 1 & 2

## NOTES:

1. BEND SHOULD BE PERPENDICULAR AT BOTH ENDS.
2. VISUALLY INSPECT PINS ITEM 5 FOR FOLLOWING:  
RADIUS CENTERED  
RADIUS TIP SHARP
3. ROUNDED EDGE OF ITEM 9 TO FACE OUT. (2 PLACES)
4. LUBRICATE SURFACE INDICATED WITH GREASE ITEM 3 (2 PLACES) EACH END.
5. BEND TAB SHOWN IN FIGURE A-A AND B-B IN THE DIRECTION SHOWN. THIS SETS THE BACKGAGE TABS TO MINIMUM SETTING USING A FLAT BLADED SCREWDRIVER.

INSTALL THE PROPER TOOL VELOBIND OR SUREBIND TOOL IN DIE SET THROAT AS SHOWN IN FIGURE A-A AND B-B SO THAT IT IS THE SLOT IN THE TOOL IS LOCATED ON THE PUNCH PIN NEAR ONE OF THE BACK GAGE TABS.

ROTATE THE TOOL UNTIL IT CONTACTS THE ADJACENT PIN. THIS WILL SET THE HEIGHT OF THE BACK GAGE TABS.

REPEAT THIS PROCESS FOR EACH BACK GAGE TAB.

6. THIS DRAWING IS FOR ASSEMBLY GUIDE LINE ONLY. REFER TO INDIVIDUAL PARTS DRAWING FOR DETAILS.

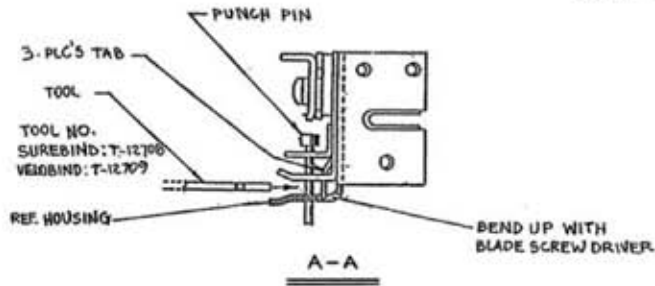
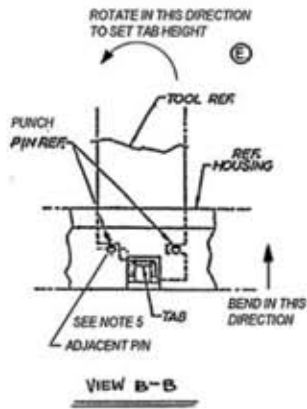
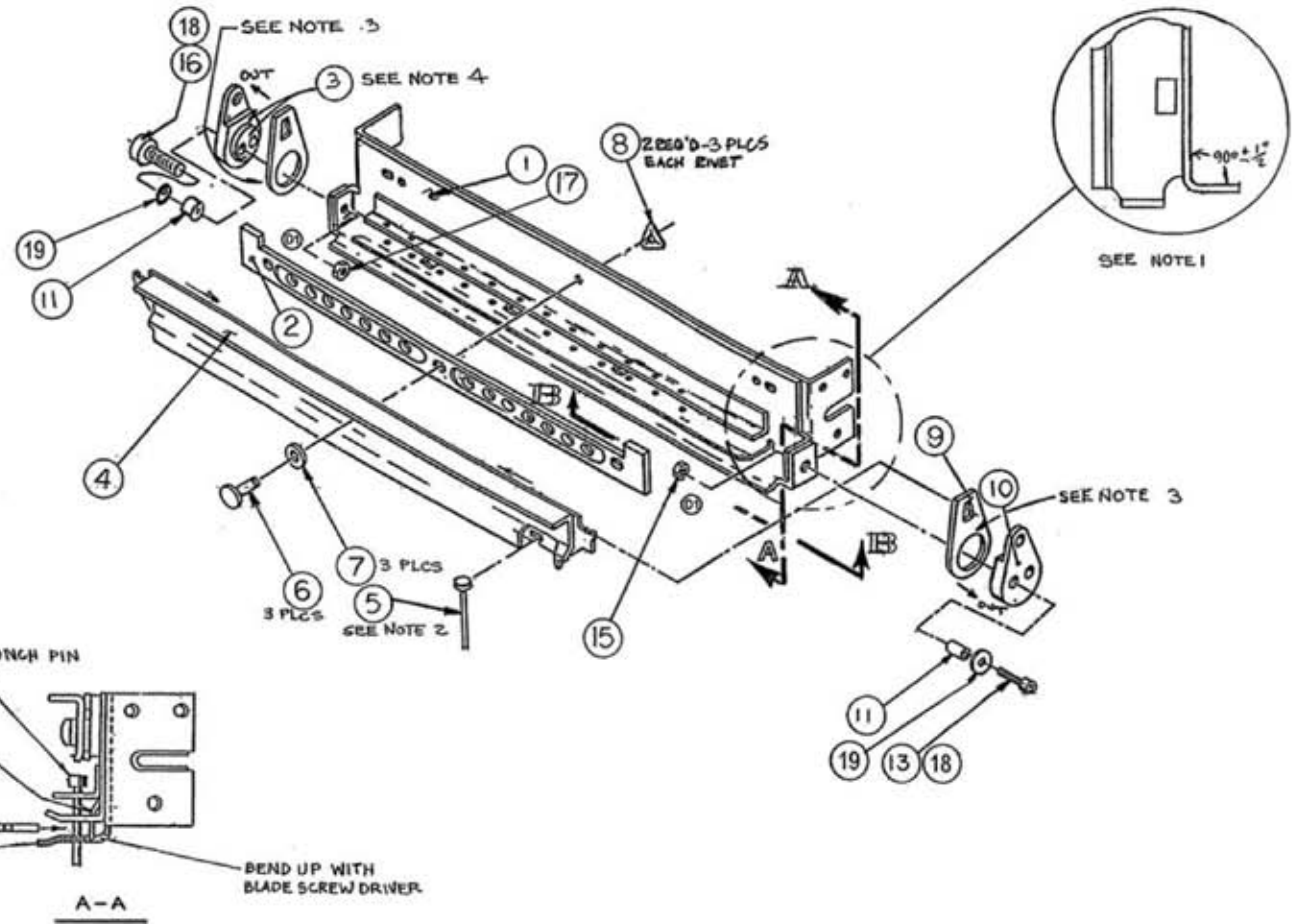

PUNCH HOUSING ASSY. PARTS LIST				
ITEM NO	DESCRIPTION	QTY	PART NUMBER	
			COMMON	9778711 SUREBIND
				9778708 VELOBIND
1	PUNCH HOUSING ASSY COMPLETE	1		9781854 9781029
2				
3	GREASE LUBRICATING	a/r	1961503	
4				
5				
6				
7				
8				
9	LINK PUNCH	2	9776446	
10	DRIVE ECCENTRIC	2	9781095	
11	SPACER	2	9779257	
12				
13	SCREW SOC HD CAP 1/4-28X1-1/8	1	1950591	
14				
15	NUT HEX 1/4- 28	1	1926710	
16	SCREW 1/4-28 x 1x1-8 LH THD SCH	1	1900527	
17	NUT 1/4-28 LH THREAD	1	1926724	
18	LOCTITE 242	0.001	1960512	
19	HARDENED WASHER	2	1925183	

# HEATER ASSEMBLY

- NOTE:  
 1. BEFORE TIGHTENING SCREW ITEM 2,  
 MAKE SURE THAT BLADE SUPPORT  
 ITEM 12, IS CENTERED IN RELATION  
 TO THE SUPPORT BAR, ITEM 7.
2. USE TRAVEL ARRESTOR QTY (1) OR (2) DEPENDING  
 UPON THE TOLERANCE STACKUP, SUREBIND ONLY

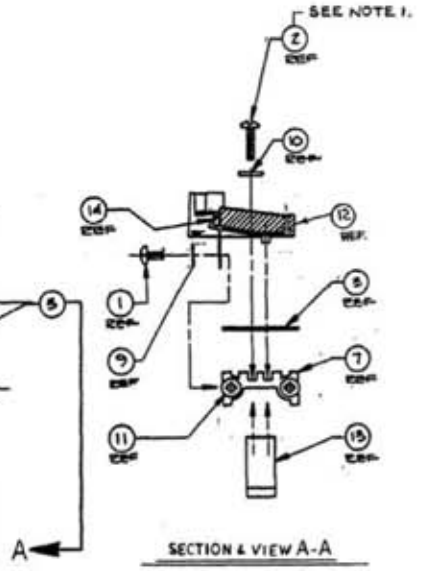
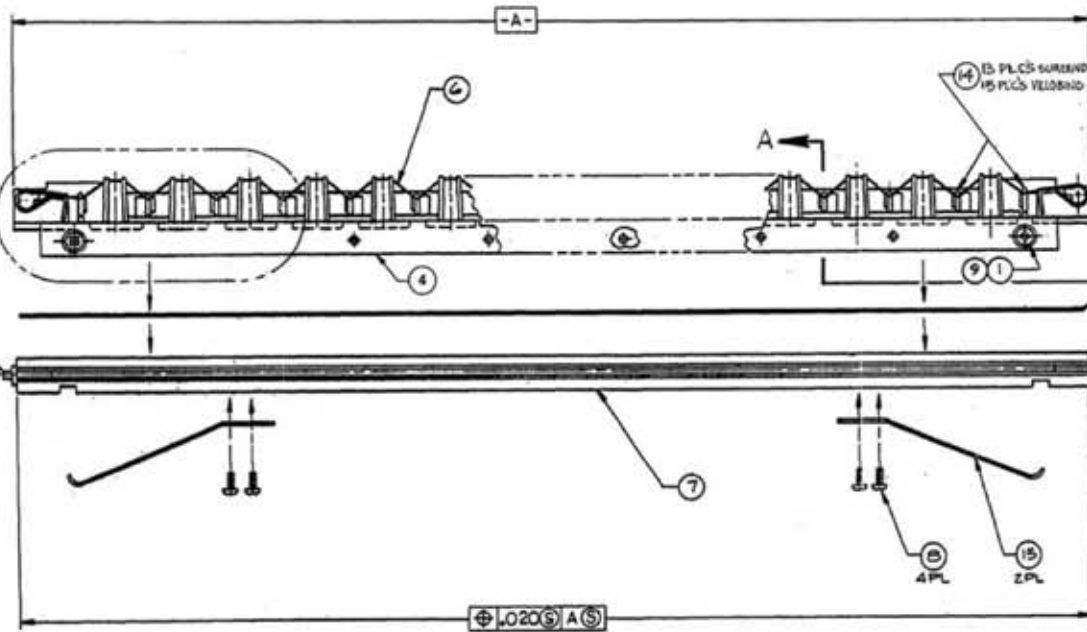
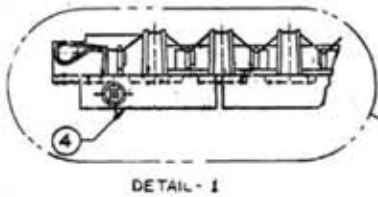
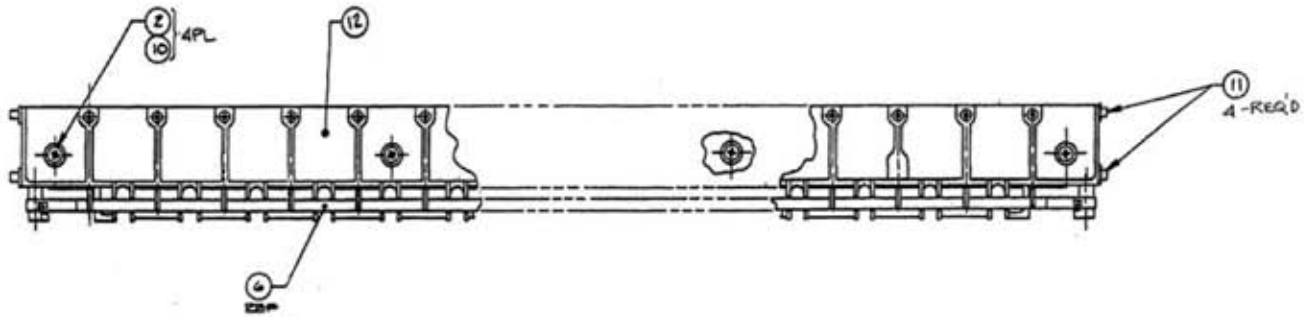

HEATER ASSY. PARTS LIST				
ITEM	DESCRIPTION	QTY	PART NUMBER	
			COMMON	9777072 SUREBIND 9776678 VELOBIND
1	SCR THD CUT PH PAN HD 6-32 X1/4		1907831	QTY-6 QTY-4
2	SCR PH PAN SELF TAP 4-24 X1/2	4	1907834	
3	INSULATOR HEATER ASSY	1		9781572 9778291
4	TRAVEL ARRESTOR			9781153 QTY-2 9780120 QTY -1
5				
6	BLADE STRIP ASSY BLK TEF	1		9781639 9781638
7	BAR SUPPORT ALUM MACHINED	1	9776664	
8	SCR PH PAN HD THD CUT 4-40 X 1/4	4	1907833	
9	WASHER FLAT # 6		1925119	QTY-6 QTY -4
10	WASHER FLAT .125ID	4	1925012	
11	STUD HEATER	4	9779352	
12	SUPPORT BLADE	1		9777029 9779293
13	SPRING SUPPORT	2	9781163	
14	SPRING TENSIONER	13 OR 15	9779268	QTY-13 QTY-15

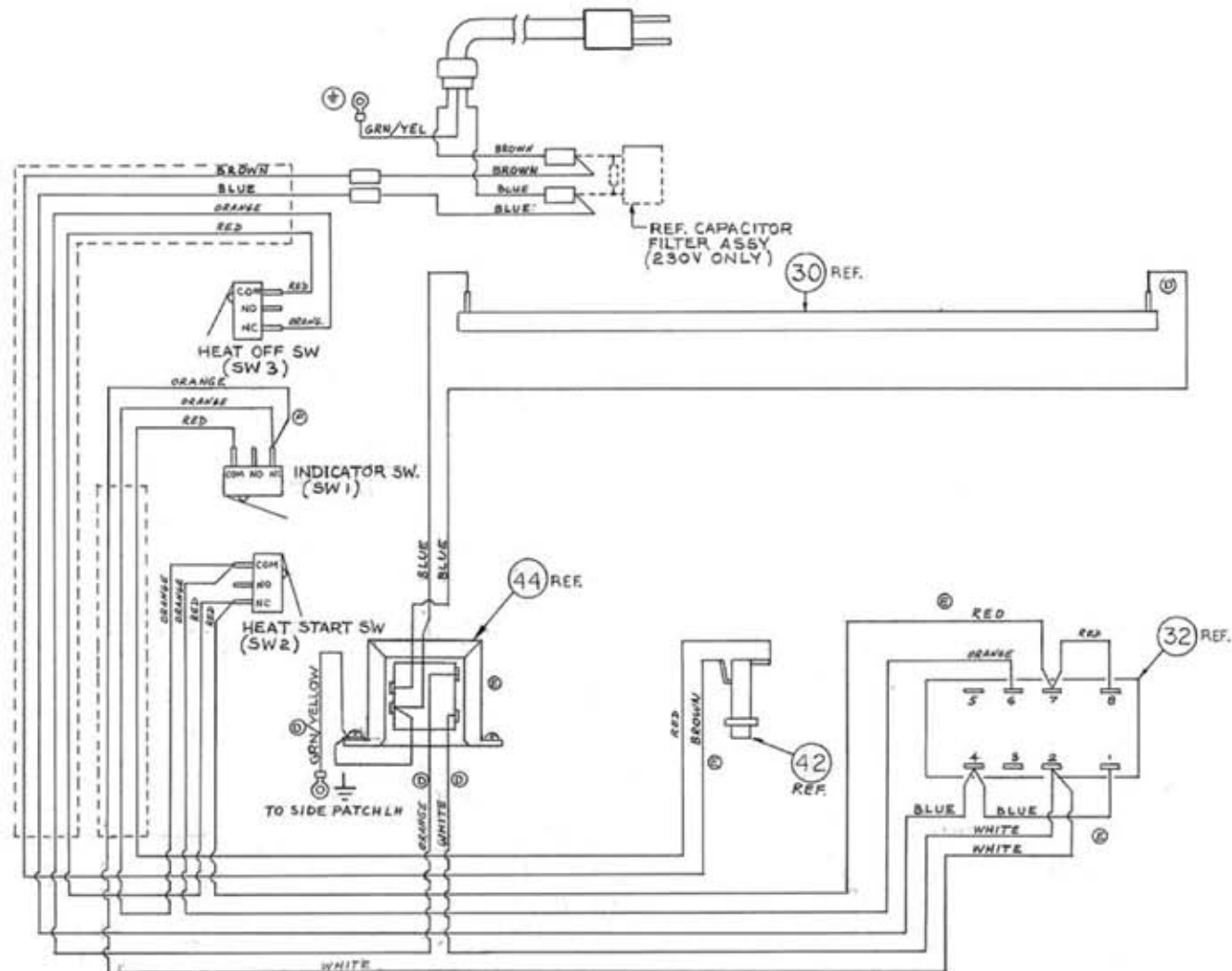

**WIRING DIAGRAM**

**ELECTRICAL SCHEMATIC**

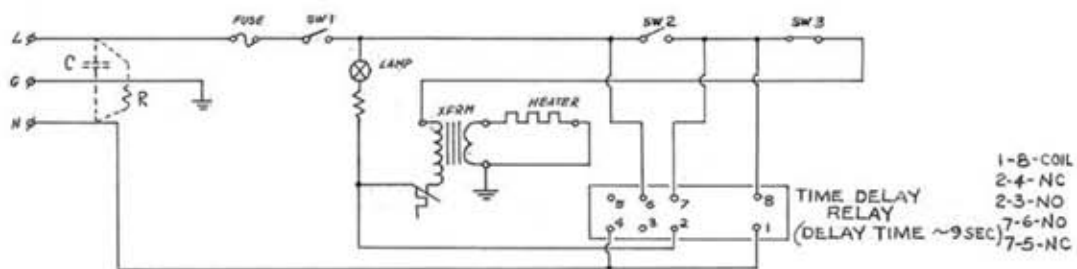

- 1-B-COIL
- 2-4-NC
- 2-3-NO
- 7-6-NO
- 7-5-NC

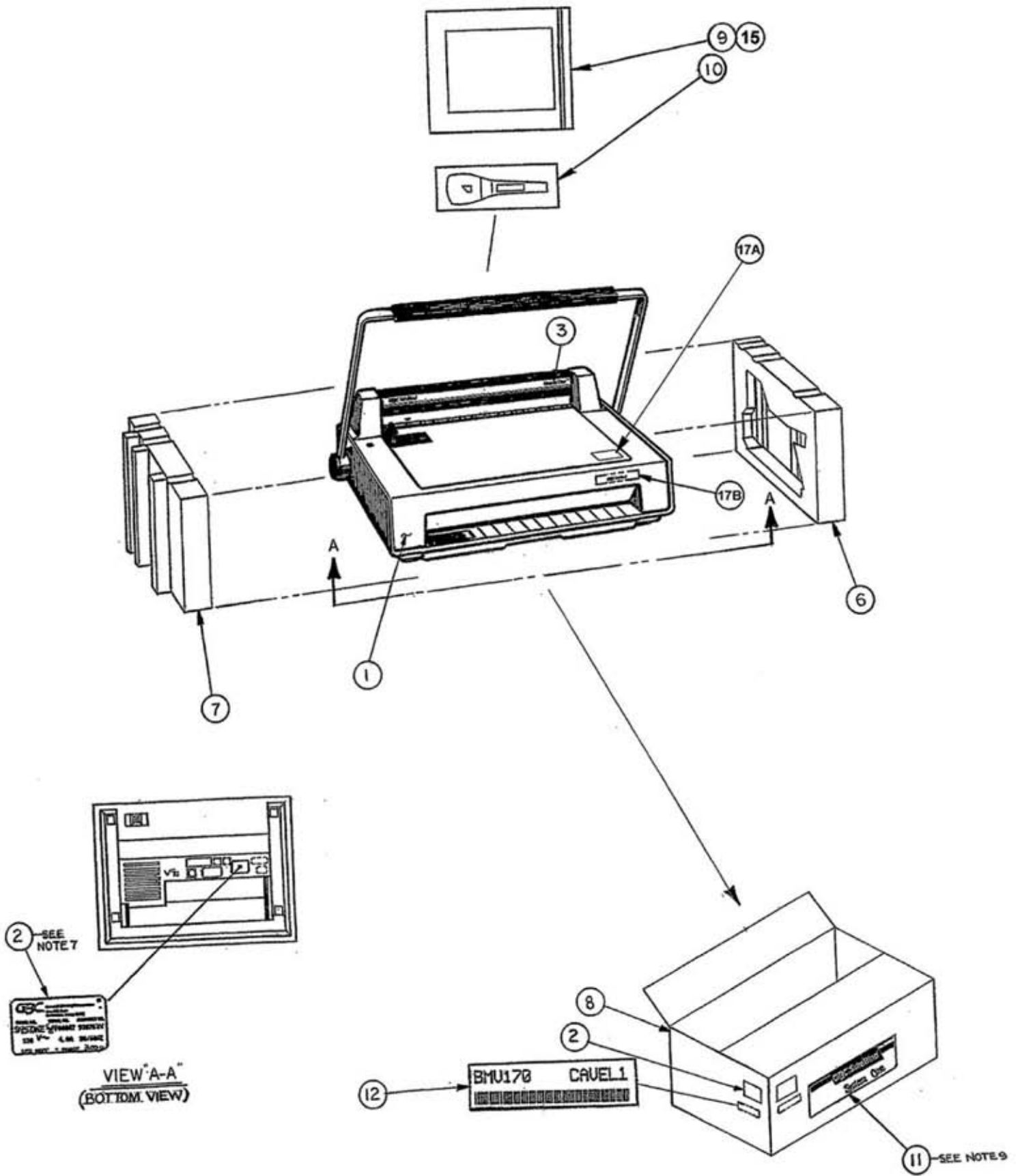

**SYSTEM ONE PACKAGING ASSY**

17B	NAMEPLATE LOGO SYS ONE	1		7704888	---	7704888	---	7704947	7704947	7704947	----
17A	GBC LOGO LABEL - LIGHT GRAY	1	---	7704953	---	7704953	---	7704953	7704953	7704953	----
17	LABEL KIT	1		7705128	7705128 *	7705128	7705128*	7705127	7705127	7705127	7705128 *
15	BROUCHER GBC EMA BENEFITS	1	---	---	---	1630024	---	---	---	1630024	----
14	STAPLE	20	1929306								
13											
12	LABEL GENERIC 2" X 3"	2		---	4020722	---	---	---	---	---	----
11	LABEL CARTON SYSTEM ONE	2		9781298	---	9781298	9781300	9781663	9781663	9781663	----
10	DEBINDER MODEL 31 GENERIC	1	7705047								
9	UTILITY PACK - SYSTEM ONE	1		9783574	7704948	9783574	9783577	9783576	9783576	9783578	7704892
8	CARTON SHIPPING SYS I	1		9781308	9781308	9781308	9781308	9781308	9781308	9781308	7704905
7	END CAP LEFT SYS I	1	9781263								
6	END CAP RIGHT SYS I	1	9781262								
5	POLYBAB 33" X 39"	1		---	9776234	---	---	---	---	---	----
3	LOGO PB SYSTEM ONE	1			---		7704955		---		7704889
2	GBC NAMEPLATE & LABEL	1		1155000	1155011	1155000	1155011	1155000	1155000	1155000	1155018
1	SYSTEM ONE FINAL ASSEMBLY	1		7704891	7704891	7704881	7704881	7704951	7704941	7704901	7704881
			COMMON	9707021	9707160	9707023	9707024	9707049	9707050	9707053	7704870
				<u>VB-INTL</u>	<u>G/N-INTL</u>	<u>VB-DOM</u>	<u>GUSA-DOM</u>	<u>SB-JAPAN</u>	<u>SB-GRAY</u>	<u>SB-DOM</u>	<u>ibico-DOM</u>
				<u>VB-230V</u>	<u>VB, 230V</u>	<u>VB-120V</u>	<u>VB, 120V</u>	<u>SB-100V</u>	<u>230 V</u>	<u>SB, 120V</u>	<u>VB-120V</u>
<b>ITEM #</b>	<b>PART DESCRIPTION</b>	<b>QTY.</b>	<b>PART NUMBER</b>								

