



# PQ9 & PQ12 Parts List



GBC IS AN ACCO BRANDS COMPANY

## 8.0 PARTS

All parts in each illustration are keyed with an index number for reference to the respective part number, part name, and quantity in the parts list.

When ordering service parts, always include the following information:

1. Machine Model Number
2. Machine Assembly Number
3. Machine Serial Number
4. Part Number
5. Part Name
6. Quantity Required

**Note:** The Service Parts Department does not stock hardware items, standard hardware items should be procured locally.

8.0 Parts  
Figure 8.1

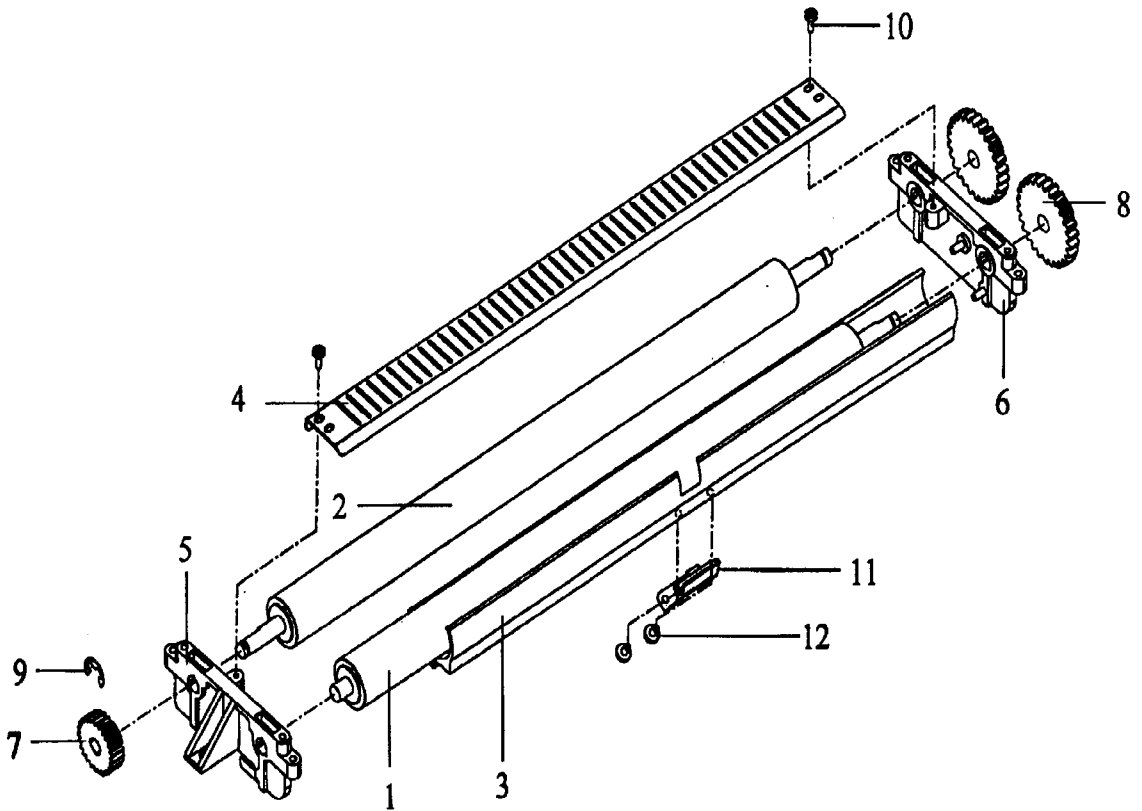

## 8.0 Parts

Figure 8.1

Item No.	Part No.	Description	Qty.
1	607010402	Heat Roller, PQ9	2
1	607010403	Heat Roller, PQ12	2
2	607010412	Pull Roller, PQ9	2
2	607010413	Pull Roller, PQ12	2
3	706021112	Lower Heater Assy.,PQ9	1
3	706021113	Lower Heater Assy.,PQ12	1
4	601160132	Film Guide, PQ9	2
4	601160133	Film Guide, PQ12	2
5	604021351	Left Side Frame	1
6	604021352	Right Side Frame	1
7	703020111	Plastic Spur Gear	2
8	703020132	Roller Spur Gear	2
9	701090605	E-Ring	2
10	70102006	Rnd Head Screw	4
11	705200124	Sensor Ass'y	1
12	701109111	Screw, M/S SAMS M3 ORH	2

8.0 Parts  
Figure 8.2

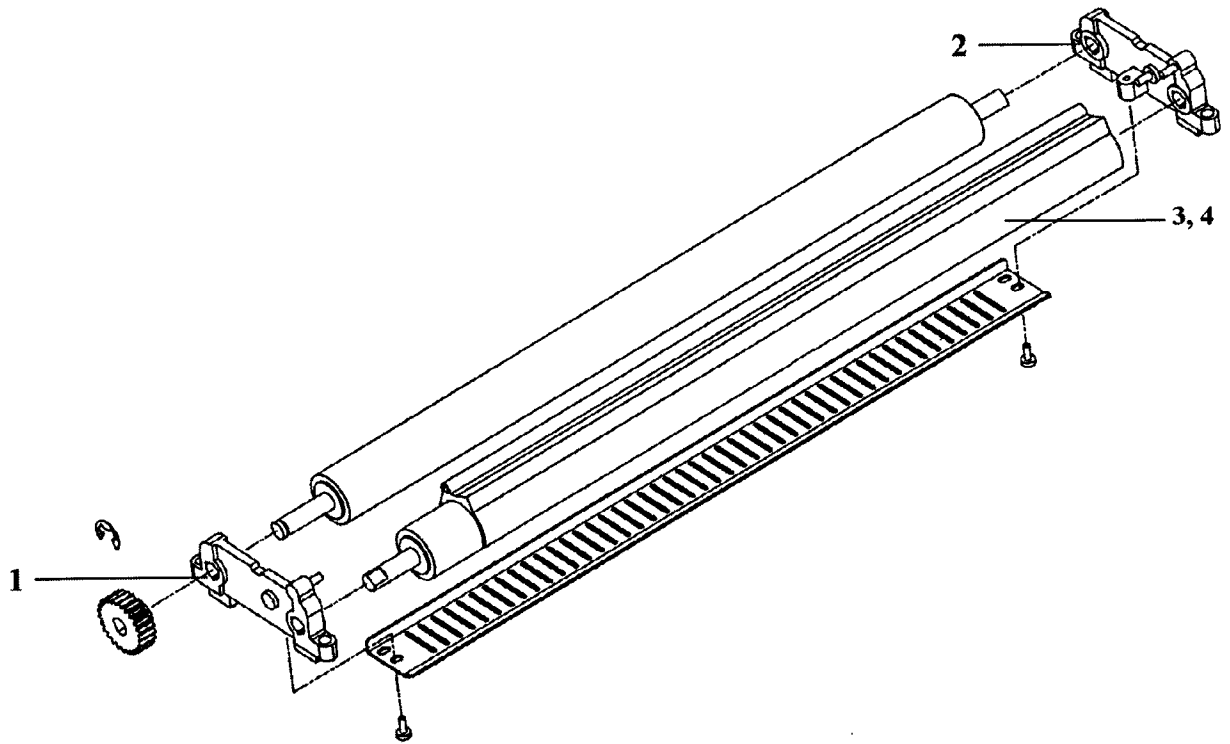

Item No.	Part No.	Description	Qty.
1	604021356	Left Side Tension Arm	1
2	604021357	Right Side Tension Arm	1
3	706021102	Upper Heater Ass'y, PQ9	1
3	706021103	Upper Heater Ass'y, PQ12	1
4	704163643	TCO, PQ9,120v	1
4	704163644	TCO, PQ12,120v	1
4	704163638	TCO, IL 9/12 PQ,230v	1

**8.0 Parts**  
**Figure 8.3**

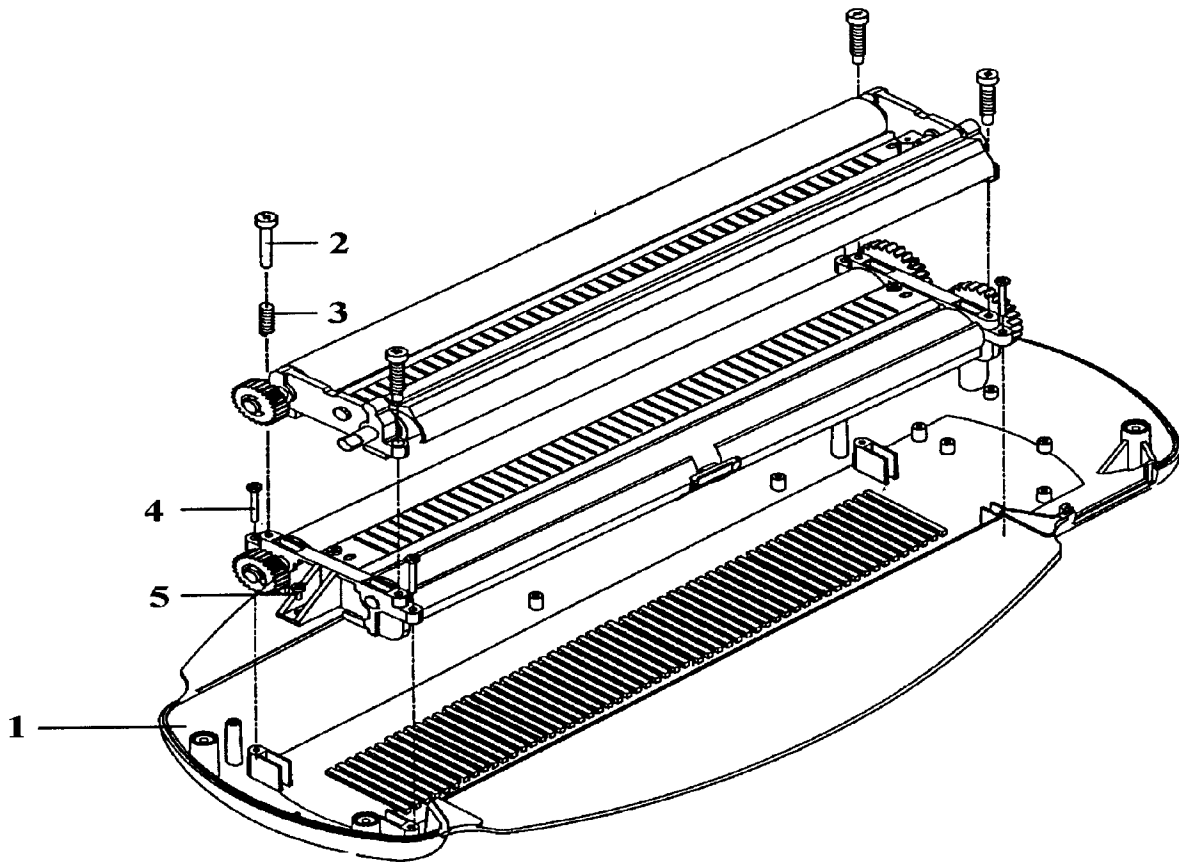

Item No.	Part No.	Description	Qty.
1	604021411	Bottom Housing, PQ9	1
1	604021412	Bottom Housing, PQ12	1
2	701108123	Shoulder Screw	4
3	701090105	Roller Spring	4
4	70102018	Rnd Head Screw	4
5	70102006	Rnd Head Screw	1

8.0 Parts  
Figure 8.4

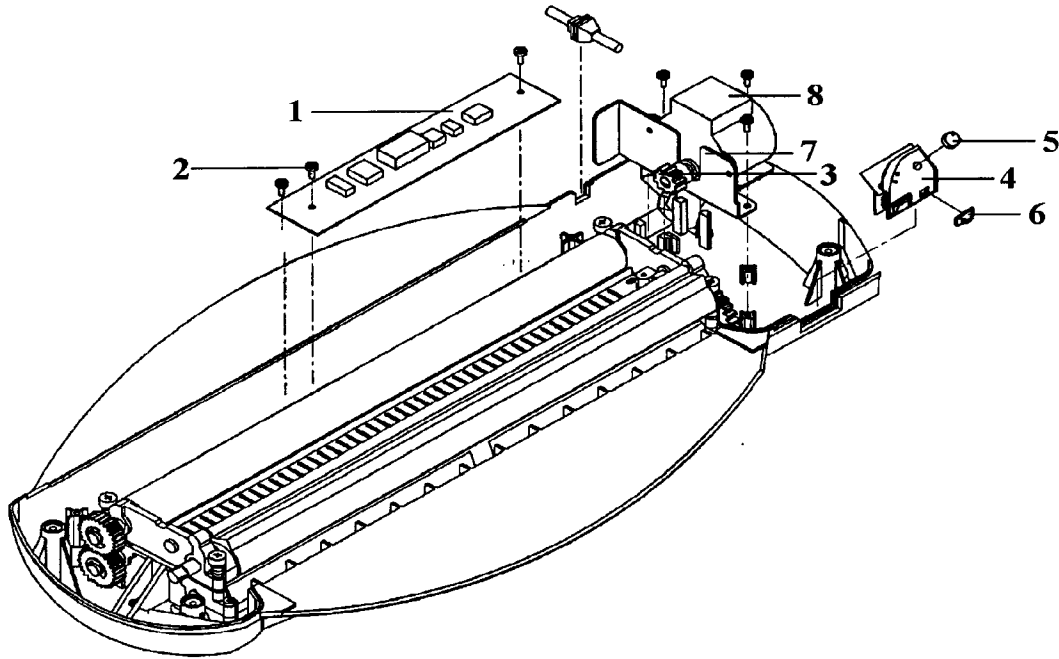

Item No.	Part No.	Description	Qty.
1	706010337	PCB Ass'y PQ	1
2	70102010	Rnd. Head Screw	9
3	703020153	Plastic Spur Gear	1
4	706051905	S/W Plate/PCB Ass'y	1
5	703021013	Plastic Knob	1
6	703021041	Plastic Slide Knob	1
7	609050312	Motor, 120v	1
7	609050311	Motor, 230v	1
8	601160171	Motor Bracket	1

8.0 Parts  
Figure 8.5

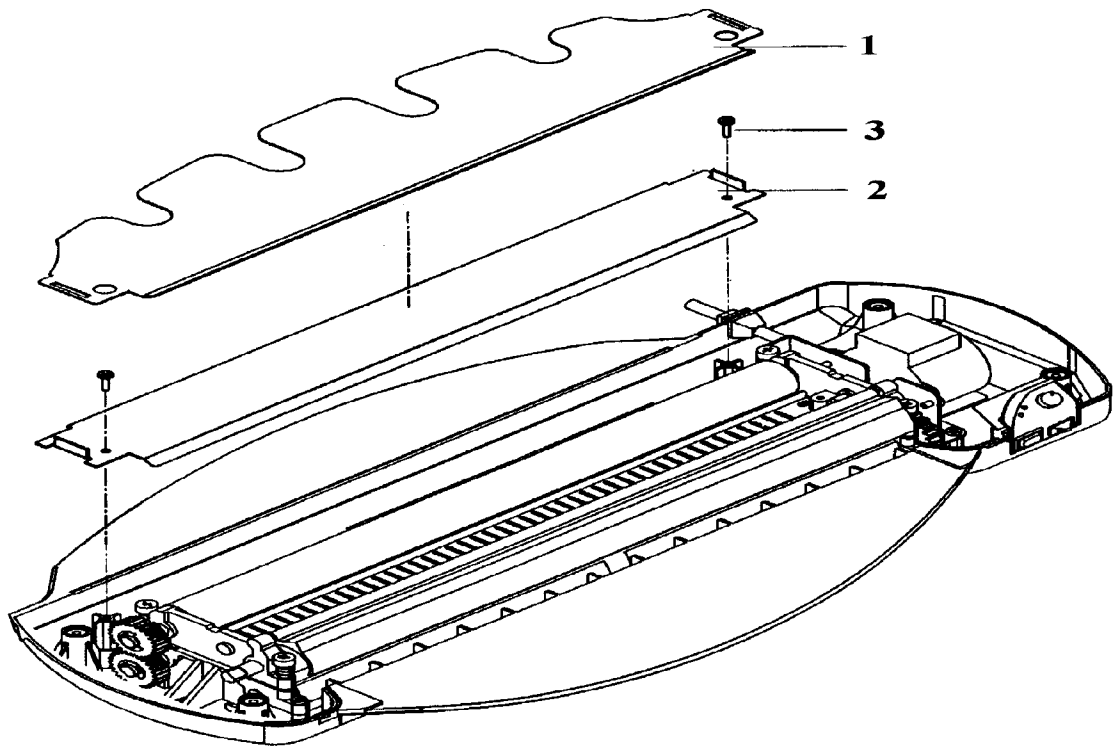

Item No.	Part No.	Description	Qty.
1	601160112	Exit Plate, PQ9	1
1	601160113	Exit Plate, PQ12	1
2	601160102	Rear Table, PQ9	1
2	601160103	Rear Table, PQ12	1
3	701102010	Rnd. Head Screw	2

**8.0 Parts**  
**Figure 8.7**

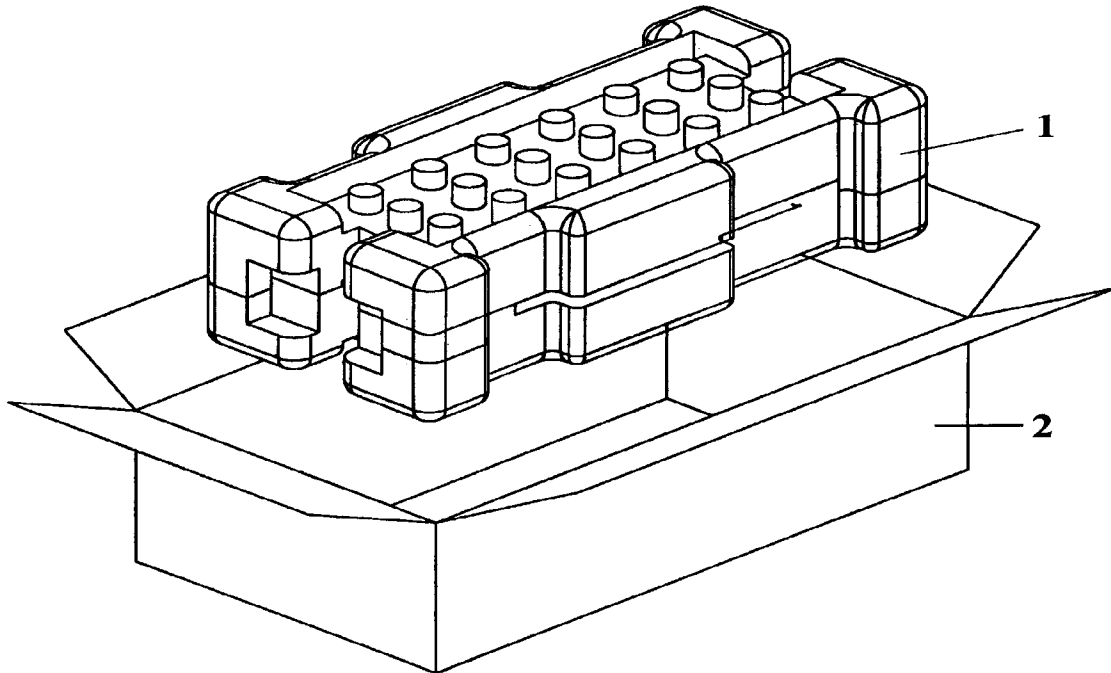

<b>Item No.</b>	<b>Part No.</b>	<b>Description</b>	<b>Qty.</b>
1	801042801	Styrofoam Inserts, PQ9	1
1	801042802	Styrofoam Inserts, PQ12	1
2	801011221	Display Box, PQ9, 120v	1
2	801011223	Display Box, PQ9, 230v	1
2	801011222	Display Box, PQ12, 120v	1
2	801011224	Display Box, PQ12, 230v	1