

ORCA-I SP Operation Manual

© 1998 GBC Pro-Tech
Do not duplicate without written permission

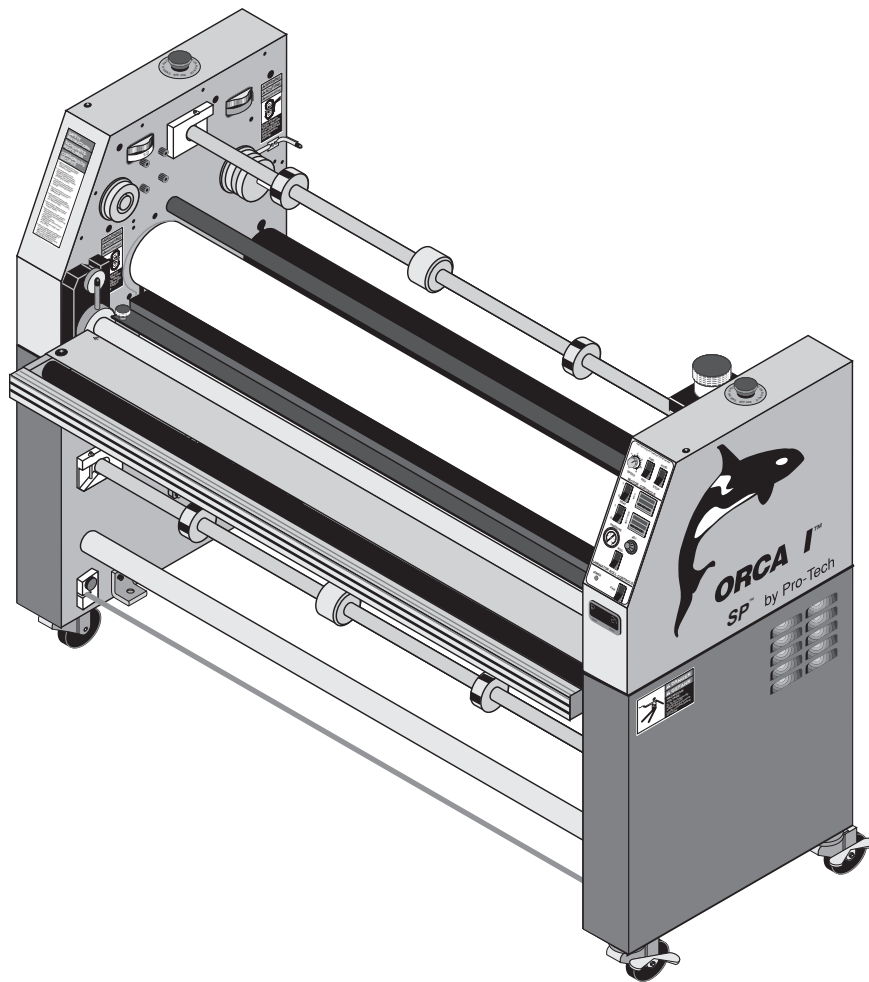

Part Number 930-011

GBC Pro-Tech
4151 Anderson Road
De Forest, Wisconsin 53532
Tel: 608-246-8844
Fax: 608-246-8645

The information in this publication is provided for reference and is believed to be accurate and complete. GBC Pro-Tech is not liable for errors in this publication or for incidental or consequential damage in connection with the furnishing or use of the information in this publication, including, but not limited to, any implied warranty of fitness or merchantability for any particular use.

GBC Pro-Tech reserves the right to make changes to this publication and to the products described in it without notice. All specifications and information concerning products are subject to change without notice.

Reference in this publication to information or products protected by copyright or patent does not convey any license under the rights of GBC Pro-Tech or others. GBC Pro-Tech assumes no liability arising from infringements of patents or any other rights of third parties.

This Manual is Copyrighted ©1998 by GBC Pro-Tech. All rights reserved. The information contained in this manual is proprietary and may not be reproduced, stored, transmitted, or transferred, in whole or in part, in any form without the prior and express written permission of GBC Pro-Tech.

Table of Contents

Section 1 : Safety	1-1
Caution/Warning Label Locations	1-5
Section 2: Installation	2-1
Preinstallation Checklist.....	2-1
Unpacking.....	2-4
Setup	2-5
Startup	2-6
Section 3: Operation.....	3-1
Safety.....	3-1
Operator Controls	3-3
Front Control Panel.....	3-3
.....	3-3
Rear Control Panel	3-4
Setup	3-4
Laminator Roll Pressure	3-4
Loading the Film	3-5
Positioning the Film	3-5
Heating	3-5
Paper Tips.....	3-6
Laminating 51" - 55" Materials	3-6
Process Control Charts.....	3-7
Mounting Only.....	3-7
Setup.....	3-7
Procedure	3-7
Mounting/Laminating	3-7
Setup.....	3-7
Procedure	3-7
Encapsulation	3-8
Setup.....	3-8
Procedure	3-8
Two-Pass Mount and Laminate (Hot and Cold).....	3-8
Setup.....	3-8
Procedure, Pass 1	3-8
Procedure, Pass 2	3-8

Vinyl Transfer	3-9
Setup	3-9
Procedure, Pass 1	3-9
Procedure, Pass 2	3-9
Section 4: Maintenance and Troubleshooting	4-1
Cleaning	4-1
Adjusting the Nip	4-3
Adjusting the Pressure Booster	4-4
Chain Tensioning	4-5
Adjusting the Air Cylinder Rate	4-6
Lubrication	4-7
Contacting Technical Support	4-7
Output Troubleshooting Guide	4-8
Section 5: Warranty	5-1
Limited Warranty	5-1
Exclusions to the Warranty	5-1
Section 6: Specifications	6-1
Section 7: Index	7-1

Section 1 : Safety

DO NOT ATTEMPT TO OPERATE YOUR ORCA-I SP LAMINATOR UNTIL YOU HAVE READ THIS SECTION CAREFULLY!

Your safety, as well as the safety of others, is important to GBC Pro-Tech. This section contains important safety information.

The following symbols are used throughout this manual to indicate warnings and cautions.



DANGER

Indicates an imminently hazardous situation which, if not avoided, will result in death or serious injury.



WARNING

Indicates a potentially hazardous situation which, if not avoided, could result in death or serious injury.



CAUTION

Indicates a potentially hazardous situation which, if not avoided, could result in minor or moderate injury, or alerts against unsafe practices, or alerts against actions which could damage the product.

The ORCA-I SP Laminator has been designed with safety as a primary consideration; however, you must become thoroughly familiar with the controls, proper operation, proper service procedures, and safety features of the laminator before using or servicing the unit.

GBC Pro-Tech laminators are powerful machines that are designed to mount, laminate and encapsulate. The forces required to accomplish these tasks can vary from negligible to very large.

The air-cylinder system used to provide downward pressure on the top roll is capable of producing forces greater than 1000 pounds (454kg). This force is applied to any object presented in the opening (called the nip) between the two rolls.

Use care in lowering the top laminating roll and know how to react quickly in an emergency. The laminator roll **UP-DOWN** switch is located on the instrument panel labeled **Laminator Roll Controls** on the upper right side of the machine. This switch controls the up and down motion of the top laminator roll. Before turning this switch to the **DOWN** position, ensure that nothing is in the nip area.

In addition, the laminating rolls of the ORCA-I SP can reach temperatures of over 200°F (100°C). At these temperatures there is a danger of a severe burn if the rolls are touched during set-up, operation or servicing.

An important feature of the laminator is the photoelectric eye system that stops the machine when objects move into the nip area. Once the blocking object is removed and the light beam reestablished, the rolls resume turning. However, this system is overridden if you use the footswitch.



WARNING

Use extreme caution when operating the laminator with the footswitch. The photoelectric eye system is overridden and your fingers can get caught in the nip. You can be crushed or burned.

The ORCA-I SP Laminator has a steel cabinet that is bolted closed to isolate the electrical and drive system components for the safety of the operator. Only a qualified service technician should open these cabinets.

The laminator is equipped with two emergency stop buttons located on the top of either side of the laminator. Either of these, if engaged, stops the laminator and raises both the main roll and pull roll. To continue operation, return both emergency stop buttons to the up position and turn the main roll **UP-DOWN** switch to the **UP** position to reset the laminator. The laminator roll **UP-DOWN** switch is located on the instrument panel labeled **Laminator Roll Controls** on the upper right side of the machine. This switch controls the up and down motion of the top laminator roll. Before turning this switch to the **DOWN** position, ensure that nothing is in the nip area.

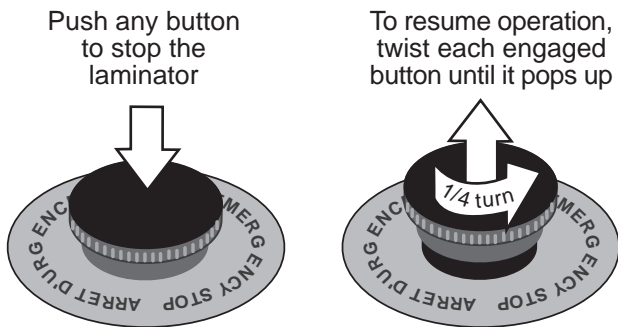

Figure 1-1: Using the Emergency Stop Buttons

In addition, the ORCA-I SP is equipped with two emergency stop kick cables located at the lower front and back of the laminator. Either of these, if stepped on or kicked, stops the laminator and raises the rolls. To continue operation, turn the main roll **UP-DOWN** switch to the **UP** position to reset the laminator. Before turning this switch to the **DOWN** position, ensure that nothing is in the nip area.

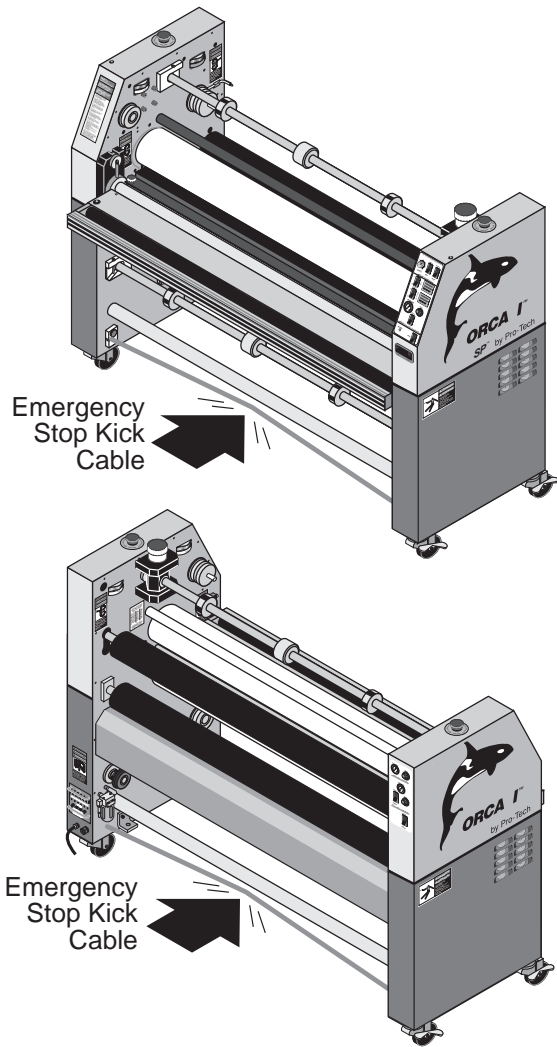

Figure 1-2: Using the Emergency Stop Kick Cables

Despite the safety features built into the ORCA-I SP Laminator, extreme caution must be used when operating or servicing the unit. **READ THE FOLLOWING WARNINGS AND CAUTIONS BEFORE YOU ATTEMPT TO OPERATE OR SERVICE THE ORCA-I SP LAMINATOR.**

**DANGER**

Never place fingers or arms between the rolls when they are turning or when the rolls are in the closed position. You can be crushed or burned.

**DANGER**

Secure long hair so that it cannot get caught in the machinery. Do not wear ties, loose fitting clothing or dangling jewelry while operating or servicing the laminator. These items can get caught in the nip, and choke you or you can be crushed or burned.

**DANGER**

Remove power from the laminator before servicing. You can be severely shocked, electrocuted or cause a fire.

**WARNING**

Do not attempt to move the laminator across anything other than a flat, level surface without trained and qualified riggers. You can be crushed or seriously injured.

The ORCA-I SP Laminator is a large and heavy piece of equipment. It is necessary to employ **LICENSED RIGGERS ONLY** to move the machine. The laminator is not designed to be tipped up or sideways in any way. Such action disturbs the exact alignment of the rolling parts of the machine and requires extensive realignment. GBC Pro-Tech's warranty does not cover malfunction of the equipment due to mishandling and/or tipping.

GBC Pro-Tech bears no responsibility for personal injury or damage due to moving the laminator improperly.

**WARNING**

Do not operate the laminator near water. You can be severely shocked, electrocuted or cause a fire.

**WARNING**

Only a qualified electrician should connect power to the laminator. You can be severely shocked, electrocuted or cause a fire if power is improperly applied.

**WARNING**

Do not operate the laminator if the power cord is damaged or frayed. You can be severely shocked, electrocuted or cause a fire. Contact a qualified electrician to replace the cord.

**WARNING**

Use extreme caution when operating the laminator with the footswitch. The photoelectric eye system is overridden and your fingers can get caught in the nip. You can be crushed or burned.

**WARNING**

Do not allow anything to rest on the power cord. Do not locate the cord where people can walk on it. You or others can be severely shocked, electrocuted or cause a fire.

**WARNING**

Always use care in lowering the top laminating roll. You can be crushed or burned.

**WARNING**

The operating environment must be free of dust, flammable liquids and vapors. You can be injured by inhaling chemical vapors. Vapor build up or stored flammable liquids can cause a fire. Excessive dust can damage the laminator.

**WARNING**

The blades in the slitters are razor sharp. You can cut yourself severely.

**WARNING**

If the air supply pressure exceeds the typical 100 psi (700 kPa) and is less than 120 psi (825 kPa), the pressure booster on the ORCA-I SP must be adjusted to avoid damage to the machine and possible injury to service technicians. During this adjustment, do not allow the main roll pressure gauge to exceed 150 psi (1030 kPa) at any point. Main roll pressures over 150 psi can damage the electric air valves.

Do not exceed 120 psi (825 kPa) for the incoming air pressure.

**WARNING**

Never insert objects of any kind through any of the slots on the laminator. You can touch dangerous voltage points or short out parts. You can be severely shocked, be electrocuted, or cause a fire.

**WARNING**

Do not use liquid or aerosol cleaners on the laminator. Do not spill liquid of any kind on the laminator. You can be severely shocked, electrocuted or cause a fire. Use only a damp cloth for cleaning the exterior.

**WARNING**

Exercise care when cleaning the rolls with 80% isopropyl alcohol:

- Use only in a well ventilated area.
 - Wear rubber gloves.
 - Use only on cool rolls.

Cleaning heated rolls can ignite the fumes.

**WARNING**

Use only 80% isopropyl alcohol or a rubber cement eraser to clean the laminating rolls. Harsh chemicals like toluene, acetone or MEK destroy the rolls' silicone covering.

**CAUTION**

Raise the upper main roll when the laminator is not in operation. Prolonged contact can damage the rolls.

**CAUTION**

Excess pressure can damage the laminating rolls. Always select the minimum roll pressure necessary to complete the task.

**CAUTION**

If silicone adhesive contacts the upper or lower roll, remove it **IMMEDIATELY** using 80% isopropyl alcohol. It can harden within an hour and ruin the roll.

**CAUTION**

Do not use a knife or other sharp instrument during installation or while servicing the laminator. You can cause irreparable damage to the rolls.

**CAUTION**

Do not block infrared temperature sensors. Main rolls could be damaged from overheating.

ALWAYS USE GOOD SAFETY PRACTICES WHEN OPERATING OR SERVICING THE LAMINATOR AND KNOW HOW TO REACT QUICKLY IN AN EMERGENCY.

Caution/Warning Label Locations

Posted at various locations on your ORCA-I SP Laminator are important safety labels. **PAY CAREFUL ATTENTION TO THESE LABELS AT ALL TIMES!** Figure 1-3 shows the location of each of these labels.

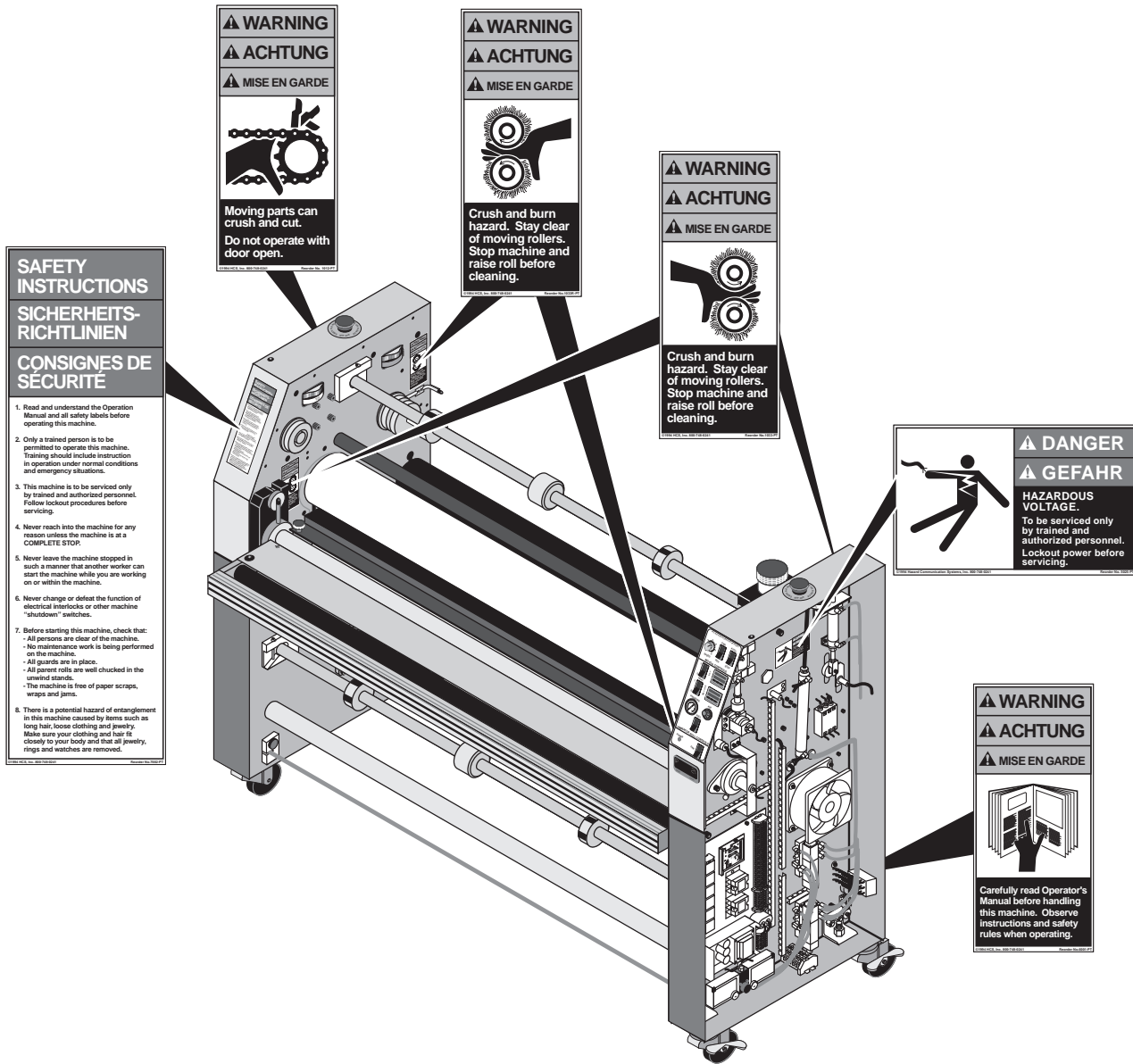

Figure 1-3: Locations of Safety Labels

Section 2: Installation

Before an ORCA-I SP Laminator can be installed there are a few requirements that must be met. Make certain that each of the requirements listed in the following preinstallation checklist are met before beginning installation.



CAUTION

Failure to follow the preinstallation checklist can result in damage to the laminator.

Preinstallation Checklist

- Are doorways and hallways wide enough for the laminator to be moved to the installation site?
- Is there ample room for the laminator?
A work area must be established that allows for operation in both the front and the rear of the machine and provides space for efficient material flow. Figure 2-1 shows a typical machine area layout.
- Is the environment appropriate for the laminator?
The laminator requires a clean, dust and vapor free office environment to operate properly. It must not be located where there is air blowing directly on the machine. Provide an environment that does not have major temperature and humidity fluctuations.



WARNING

The operating environment must be free of dust, flammable liquids and vapors. You can be injured by inhaling chemical vapors. Vapor build up or stored flammable liquids can cause a fire. Excessive dust can damage the laminator.



WARNING

The machine is not designed for use in an industrial environment.



CAUTION

Do not locate the laminator where air is blowing directly on the machine. The air flow can cool the rolls unevenly and result in poor quality output.

- Has a certified electrician been contacted to both wire the laminator and ensure that an adequate power supply is available with the appropriate capacity, over-current protection, and safety lock-outs?
The laminator requires 220 to 240 VAC, 50/60 Hz, 55A, single phase 3 wire. Or, in Europe only, 3-N phase 230/400 VAC, 50 Hz, 25A per phase.

USA - For single phase 3 wire, L1, L2, and L3 are tied together with a jumper bar on the main terminal block.

Europe - For 3-N phase, L1, L2, and L3 are each separate phases. The jumper bar must be removed on the main terminal block.



WARNING

Do not operate the laminator if the power cord is damaged or frayed. You can be severely shocked, be electrocuted, or cause a fire. Contact a qualified electrician to replace the cord immediately.



WARNING

Do not allow anything to rest on the power cord. Do not locate the cord where people can walk on it. You or others can be severely shocked, be electrocuted, or cause a fire.

- Is there an appropriate filtered air supply available?

The laminator requires filtered air at 2 cubic feet per minute (cfm), at a pressure of 100 pounds per square inch (psi) (700 kPa). The air supply must be clean (free of dirt) and dry. Moisture causes corrosion and particles block pneumatic controls. Either problem can cause the laminator to malfunction.

**WARNING**

Do not exceed 120 psi (825kPa) for the incoming air supply pressure.

If the air supply exceeds the typical 100 psi (700kPa) and is less than 120 psi (825kPa), the pressure booster on the ORCA-I SP must be adjusted to avoid damage to the machine and possible injury to service technicians.

If the air supply is greater than 100 psi and less than 120 psi (825 kPa), complete *Adjusting the Pressure Booster* under *Section 4: Maintenance and Troubleshooting*.

It is the customer's responsibility to provide appropriate filters and water traps for the air hose before the air is routed to the laminator. GBC Pro-Tech suggests that the best approach to the air requirement is to provide a dedicated small compressor for the laminator. A standard light-duty $\frac{1}{2}$ to $\frac{3}{4}$ horse power (1kW) electric air compressor with 2.0 to 2.5 cfm output with a 2.5 gallon (20 liter) storage tank is appropriate.

**CAUTION**

The air supply to the laminator must be clean and dry to avoid damaging the machine.

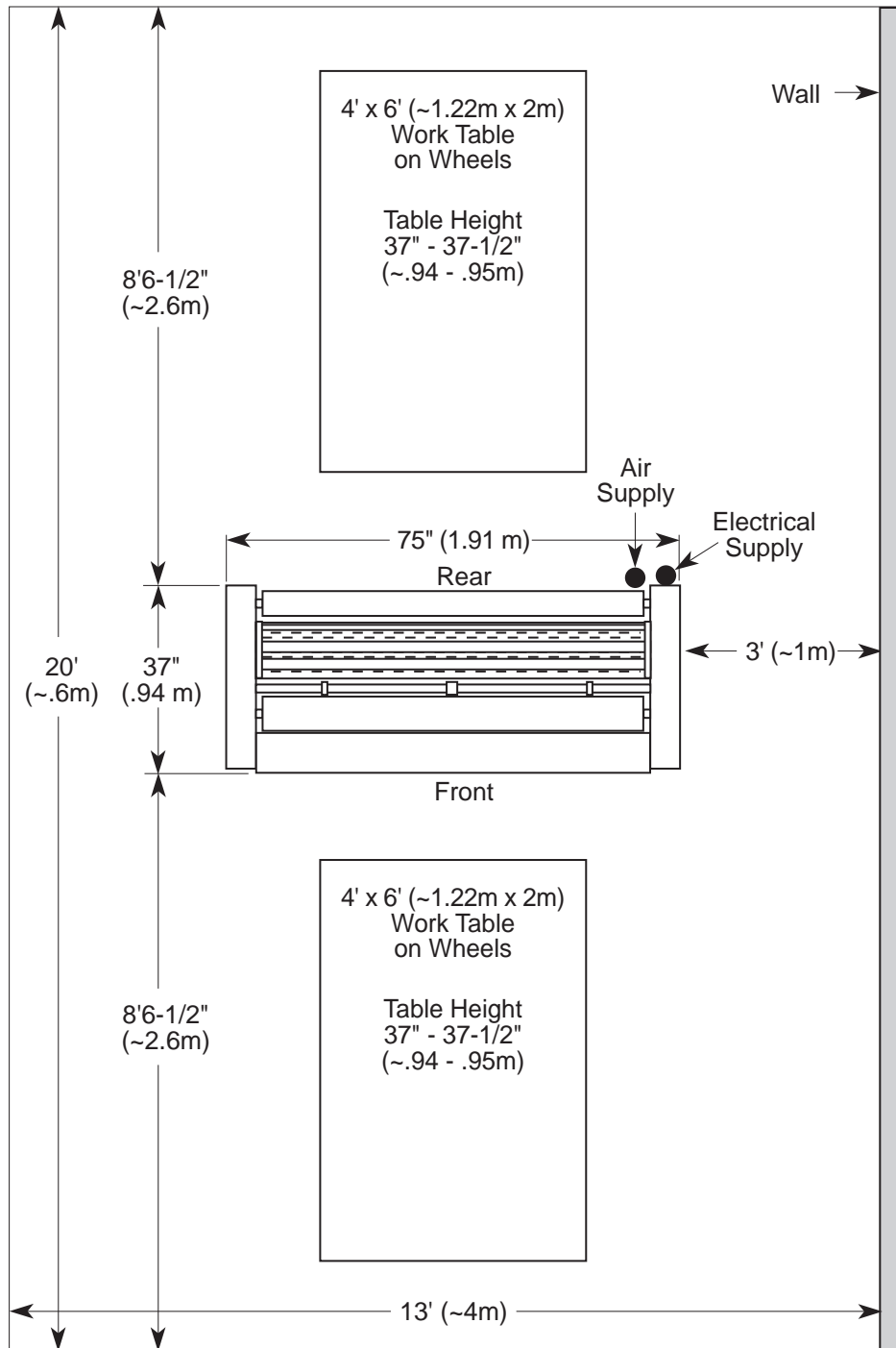

Figure 2-1: Laminator Space Requirements

Unpacking

NOTE

ALL SHIPMENTS ARE EX- WORKS. At our dock, title passes to the buyer. Please review your insurance coverage prior to shipment, as you are responsible for all subsequent freight charges and risks. Before signing the Bill of Lading, be sure to inspect the crate and/or pallet for signs of damage or missing items; if applicable, make a note of this on the Bill of Lading.



WARNING

The unpacking process requires at least two people. You can be severely injured or crushed.

Tools required:

- Phillips head screwdriver
- 7/8" open end wrench or adjustable wrench

To uncrate the laminator:

1. Remove the top of the crate and then the sides in the order shown in Figure 2-2.



CAUTION

Do not allow the top to fall into the crate. It can damage the laminator.

Do not put packing screws on the floor. They can cause problems when trying to roll the machine into position.

A second person must support the side labeled 5 in Figure 2-2. It can fall and damage the laminator.

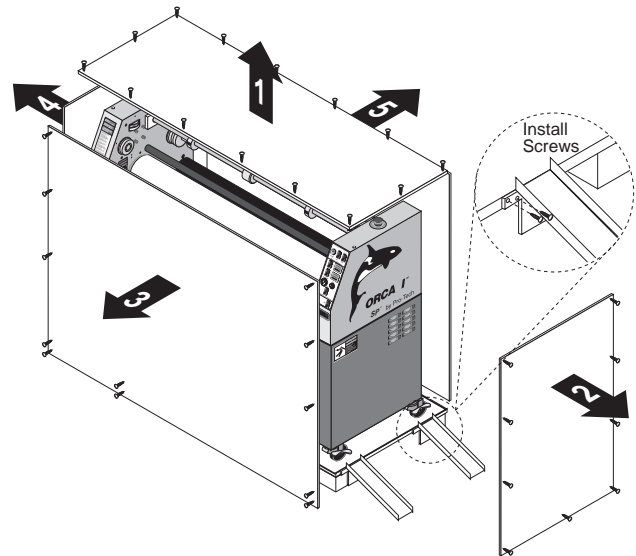

Figure 2-2: Removing the Crate

2. Gently unwrap the shrink wrap from around the laminator.



CAUTION

Do not use a knife or other sharp instrument during installation or while servicing the laminator. You can cause irreparable damage to the rolls.

3. Carefully remove any accessories packed with the laminator. The accessory pack should contain:
 - 1 Set of hex wrenches
 - 1 Slitting knife
 - 1 Manual
 - 1 Set of spare fuses
 - 1 Tape measure
 - 1 Roll of masking tape
 - 1 Rubber cement eraser
 - 1 Air line quick-couple female connector
 - 4 Leveling pads
4. Have the laminator lifted off the skid and placed on the floor by licensed riggers. The ramps included with the laminator can be secured to the edge of the crate bottom using the screws left over from the crate disassembly (see Figure 2-2).

**WARNING**

Do not attempt to move the laminator across anything other than a flat, level surface without trained and qualified riggers. You can be crushed or seriously injured.

The ORCA-I SP is a large and heavy piece of equipment. It is necessary to employ LICENSED RIGGERS ONLY to move the machine. The laminator is not designed to be tipped up or sideways in any way. Such action disturbs the exact alignment of the rolling parts of the machine and requires extensive realignment.

GBC Pro-Tech's warranty does not cover malfunction of the equipment due to mishandling and/or tipping.

GBC Pro-Tech bears no responsibility for personal injury or damage due to moving the laminator improperly.

5. Remove any plastic strapping and packing paper taped to the rolls.

**CAUTION**

Do not use a knife or other sharp instrument during installation or while servicing the laminator. You can cause irreparable damage to the rolls.

6. Remove all packing materials to a safe distance from the laminator.

 **A NOTE ABOUT RECYCLING**

The crate components can be reused for shipping the machine again, or can be disassembled and the wood and screws can be recycled. The shrink wrap is not recyclable, however, so it must be discarded.

 **NOTE**

A word about international shipments: As these are heavy pieces of equipment, GBC Pro-Tech takes every precaution to ensure that our laminators are properly crated to the highest standards.

Before machines leave our loading dock, they are pre-treated with a VCI protective film to provide total corrosion protection. This protective film is wrapped around the machine and completely sealed. In addition, moisture absorbing silicone desiccite packs are packed inside the crate and machine cabinets.

Prior to start up of the machine, you must remove the desiccite packs from each cabinet and discard. DO NOT operate the machine with the desiccite packs inside the cabinets.

Setup

Once the ORCA-I SP Laminator has been unpacked and moved into final position check each of the following items.

Tools required:

- 1/8" hex wrench
- Adjustable wrench

Setup Procedure

1. Inspect the laminator for any obvious shipping damage.
2. Remove the drive and control side cabinet covers with the 1/8" hex wrench by removing the upper six screws holding each cover in place and then loosening, but not removing, the lower two screws and lifting each panel off the lower screws.
3. Inspect all the bolts and tighten any that were loosened during shipping.
4. Have a certified electrician wire the laminator directly to a power source.
5. Set the nip. (See *Section 4: Maintenance and Troubleshooting* for the procedure.)
6. Verify that infrared sensors are clean and have an uninterrupted view of the rolls.

**WARNING**

ALWAYS CHECK THE INFRARED SENSORS PRIOR TO OPERATION! The sensors must be clean and have free view of the roll to maintain proper roll operating temperatures. The rolls can overheat and cause a fire or seriously damage the laminator.

7. Verify that the photoelectric eyes are working properly. (See *Section 5: Adjustments* for the procedure.)
8. If the rolls do not go up and down evenly, adjust the air cylinder rate. (See *Section 4: Maintenance and Troubleshooting* for the procedure.)
9. Replace both cabinet covers.

Startup

The first time the laminator is started and every time it is serviced you should use the following checklist to confirm that the unit is operating properly and that all safety mechanisms are functioning.

Startup Checklist

Start the laminator and go through the following checklist.

- Are the emergency stop buttons working?
Push down on one of the emergency stop buttons. The laminator should stop and both the upper main roll and upper pull roll should rise, if they are lowered. Twist the button until it pops up. If the main roll **UP-DOWN** switch is in the **UP** position, the machine is reset once the emergency stop button is released. If the switch is in the **DOWN** position, it must be set to the **UP** position to reset the machine. Always check both buttons.

**WARNING**

Never operate the laminator unless both of the emergency stop buttons are functioning properly. You can be crushed or burned.

- Are the emergency stop kick cables working?
With the laminator running, step on or kick the

front emergency stop kick cable. The rolls should stop turning and rise, if they are lowered. If the main roll **UP-DOWN** switch is in the **UP** position, the machine is reset once tension is released from the kick cable. If the switch is in the **DOWN** position, it must be set to the **UP** position to reset the machine. Repeat the test for the back emergency stop kick cable.

**WARNING**

Never operate the laminator unless both of the emergency stop kick cables are functioning properly. You can be crushed or burned.

- Is the photoelectric eye system working?
With the laminator running, place an object approximately the size of your hand just in front of the nip to confirm that the photoelectric eye system is functioning. The rolls should stop. Move the object away from the nip. The laminator should resume operation.

**WARNING**

Never operate the laminator unless the photoelectric eye system is functioning properly. You can be crushed or burned.

- Is the motor functioning?
Test the motor at various speeds ranging from 0-14 fpm (feet per minute) (0-4.25 m/min). At 0 fpm, the rolls should stop turning. Run the motor in both forward and reverse.
- Are the heaters working?
Verify that the top heater controller heats the top roll and the bottom heater controller heats the bottom roll.
- Is the footswitch operating?
Test the footswitch for both forward and reverse operation. Verify that the footswitch overrides the photoelectric eye by pressing the footswitch and pushing an object as large as your hand into the nip area.

Once you have completed the startup checklist, you can safely run a test sample.

Section 3: Operation

Safety

GBC Pro-Tech laminators are powerful machines that are designed to mount, laminate and encapsulate. The forces required to accomplish these tasks can vary from negligible to very large.

The air-cylinder system used to provide downward pressure on the top roll is capable of producing forces greater than 1000 pounds (454kg). This force is applied to any object presented in the opening (called the nip) between the two rolls.

Use care in lowering the top laminating roll and know how to react quickly in an emergency. The laminator roll **UP-DOWN** switch is located on the instrument panel labeled **Laminator Roll Controls** on the upper right side of the machine. This switch controls the up and down motion of the top laminator roll. Before turning this switch to the **DOWN** position, ensure that nothing is in the nip area.

The laminating rolls of the ORCA-I SP can reach temperatures of over 200°F (100°C). At these temperatures there is a danger of a severe burn if the rolls are touched during set-up, operation, or servicing.

An important feature of the laminator is the photoelectric eye system that stops the machine when objects move into the nip area. Once the blocking object is removed and the light beam is reestablished, the rolls resume turning. However, this system is overridden if you use the footswitch.



WARNING

Use extreme caution when operating the laminator with the footswitch. The photoelectric eye system is overridden and your fingers can get caught in the nip. You can be crushed or burned.

The ORCA-I SP Laminator has a steel cabinet that is bolted closed to isolate the electrical and drive system components for the safety of the operator. Only a qualified service technician should open these cabinets.

The laminator is equipped with two emergency stop buttons located on the top of either side of the laminator. Either of these, if engaged, stops the laminator and raises both the main roll and pull roll. To continue operation, return both emergency stop buttons to the up position and turn the main roll **UP-DOWN** switch to the **UP** position to reset the laminator. The laminator roll **UP-DOWN** switch is located on the instrument panel labeled **Laminator Roll Controls** on the upper right side of the machine. This switch controls the up and down motion of the top laminator roll. Before turning this switch to the **DOWN** position, ensure that nothing is in the nip area.

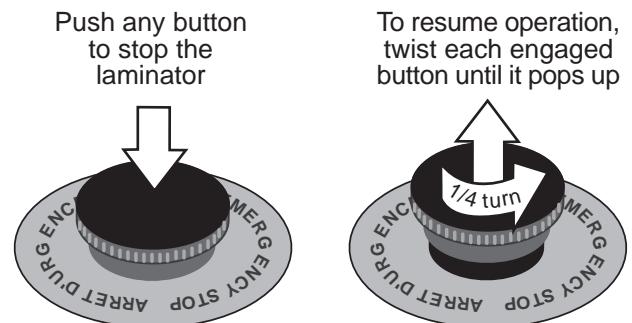

Figure 3-1: Using the Emergency Stop Buttons

In addition, the ORCA-I SP is equipped with two emergency stop kick cables located at the lower front and back of the laminator. Either of these, if stepped on or kicked, stops the laminator and raises the rolls. To continue operation, turn the main roll **UP-DOWN** switch to the **UP** position to reset the laminator. Before turning this switch to the **DOWN** position, ensure that nothing is in the nip area.

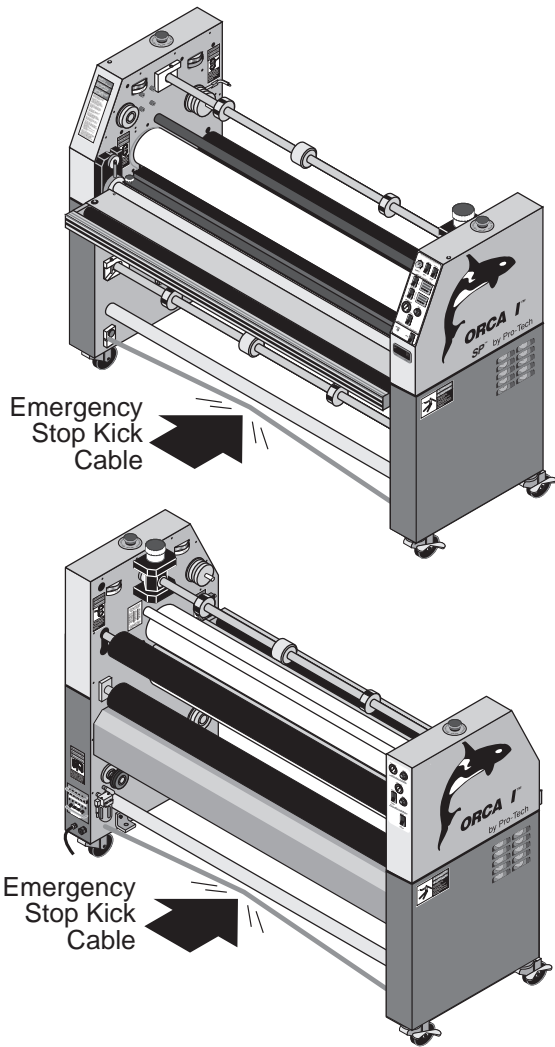

Figure 3-2: Using the Emergency Stop Kick Cables

In addition to the safety features built into the ORCA-I SP Laminator, extreme caution must be used when operating or servicing the unit.

Operator Controls

The operator controls for the ORCA-I SP Laminator are located on the front and rear of the unit, to the right of the operator position. The names and functions of these controls are as follows:

Front Control Panel

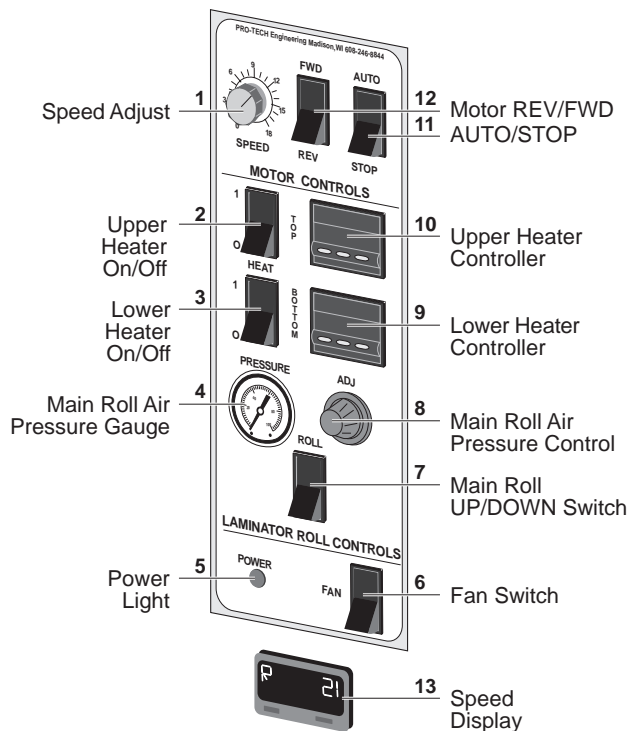

Figure 3-3: Front Control Panel

1. **SPEED ADJUST** - Adjusts the speed of the machine from zero to maximum as the control is turned clockwise.
2. **UPPER HEATER ON/OFF** - Turns the heater controller for the top laminating roll on or off.
3. **LOWER HEATER ON/OFF** - Turns the heater controller for the bottom laminating roll on or off.
4. **MAIN ROLL AIR PRESSURE GAUGE** - Displays the air pressure pushing the main laminating roll down.
5. **POWER LIGHT** - Indicates when the main power is being applied to the machine.
6. **COOLING FAN ON/OFF** - Turns the cooling fan on or off.

7. **MAIN ROLL UP/DOWN** - Sets the main roll to the up (load) or down (operate) position.
8. **MAIN ROLL AIR PRESSURE CONTROL** - Varies the air pressure fed to the cylinders that drive the top laminating roll down.
9. **LOWER HEATER CONTROLLER** - Provides a readout of the temperature of the bottom laminating roll and the set-point for the desired temperature. Both heaters must be on for either heater to function.
10. **UPPER HEATER CONTROLLER** - Provides a readout of the temperature of the upper laminating roll and the set-point for the desired temperature.
11. **AUTO/STOP** - Starts machine for continuous run. Stops machine when in Auto Run mode.
12. **MOTION CONTROL FORWARD/STOP REVERSE** - Sets the direction of the drive system - forward, stop, or reverse.
13. **SPEED DISPLAY** - Provides digital readout of the machine speed and total throughput in either metric or standard units.

Rear Control Panel

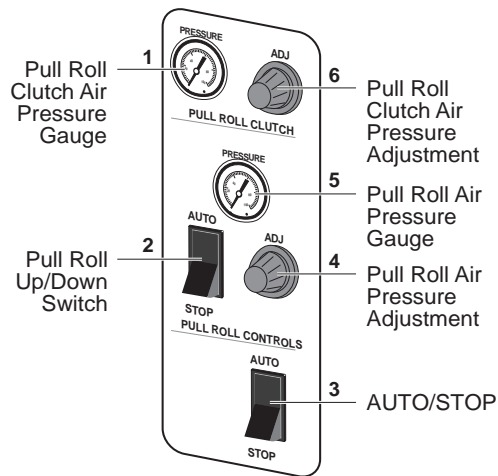

Figure 3-4: Rear Control Panel

- PULL ROLL CLUTCH AIR PRESSURE GAUGE** - Measures and displays the air pressure driving the pull roll clutch.
- PULL ROLL UP/DOWN** - Sets the pull roll to the up (load) or down (operate) position.
- AUTO/STOP** - Starts machine for continuous run. Stops machine when in Auto Run mode.
- PULL ROLL AIR PRESSURE ADJUSTMENT**- Varies the air pressure fed to the cylinders that drive the pull roll down.
- PULL ROLL AIR PRESSURE GAUGE** - Measures and displays the air pressure pushing the pull roll down.
- PULL ROLL CLUTCH AIR PRESSURE ADJUSTMENT** - Adjusts the pull roll clutch air pressure from zero to maximum as the control is turned clockwise.

Setup

Setup of the ORCA-I SP Laminator is quick and straightforward when instructions are followed exactly.



Always use the same shim settings on the left and right side of the laminator.

To adjust the nip, please see *Section 4: Maintenance and Troubleshooting*.

Laminator Roll Pressure

Use only the minimum amount of roll pressure needed to accomplish the task. While higher pressure can make the adhesive bond faster, excess pressure can damage the rolls. Wrinkles and bubbles have causes that generally cannot be cured by applying more pressure.



Excess pressure can damage the laminating rolls. Minimum laminator roll pressure is consistent with good results.

A typical roll pressure for soft substrates such as Foam-core is between 20 to 30 pounds per square inch (psi) or 140 to 205 kPa.

The range of typical values for hard substrates is 25 to 50 psi or 170 to 345 kPa.



The blades on the slitters are razor sharp. If caution is not used while loading materials, you can cut yourself severely.

Loading the Film

Film is loaded on the appropriate unwinds. Loading and aligning the film are discussed later in this section. For applications such as encapsulation, film is fed from both the top and bottom feed unwinds.

The process of loading and aligning film is the same for both the top and bottom unwinds. There are two important points to remember when loading film:

1. The adhesive side of the film must be oriented away (on the outside) from the laminating roll. Otherwise it immediately bonds to the roll, creating a major clean-up project.

Films have a shiny side and a dull side. The dull side is the one with the adhesive. The dull side should **ALWAYS** face outward from the laminating roll.



CAUTION

Always mount the film so that the adhesive side faces outward from the laminating roll. This prevents hours of roll cleaning.

2. The film must be centered on the unwind for best performance. This is vital when two films are fed together. If the two films are not aligned, feed problems, wrinkles and other problems occur.

NOTE

55" wide material must be slightly off-center for it to clear the unwind brake mounting brackets.



CAUTION

Carefully align the two films being fed into the nip. Misaligned films can result in poor quality.

Positioning the Film

The following procedure is applicable to both the top and bottom feed unwinds.

1. Open the top unwind by removing the pin and swinging the arm out.
2. Load the film.
3. Return the arm to its locked position and reinsert the locking pin.
4. Center the film on the unwind arm by measuring the distance from the ends of the film to the sides of the machine using a tape measure.

Heating

Use the following instructions when heating one or both of the laminating rolls. The procedure is the same for the top and bottom heaters.

1. Set the heater switch to ON. Both controllers must be on for either roll to heat. To heat only one roll, adjust the set point for the other roll to a value that does not call for heat (e.g. 32).
2. Adjust the temperature controller for the desired operating temperature using the temperature controller push buttons.
3. When heating the rolls, keep the top roll down and turning at a moderate speed to prevent uneven heating.

It takes approximately 30 minutes for the laminating roll(s) to reach operating temperature. When the preset operating temperature has been reached, the machine is ready to use.

The ORCA-I SP can be used for cold mounting while maintaining the temperature of the main laminating rolls by using the pull rolls as a laminator (by feeding prints from the rear) for a quick change-over between hot and cold laminating.

Paper Tips

Always feed prints perpendicular to the laminating rolls.

Laminating 51" - 55" Materials

When installing or moving 51" - 55" rolls of film, the hinge side of the roll could be damaged unless the following steps are followed (see Figure 3-5):

1. Lock core support to middle of the shaft. Lock two core chucks on shaft ends, located to support material a few inches from ends of the roll.

Note

The paper unwind might require two evenly spaced core supports.

2. Place the roll on the unwind shaft.
3. Carefully close the unwind shaft, holding the roll away from the hinge (to prevent pinching the end of wide rolls).
4. When the shaft is in the saddle, push in the locking pin.
5. Center the roll of material.

Note

Position 55" rolls slightly off-center as needed to clear the brake support bracket.

6. Web and tension the film according to the selected process control chart and diagram.

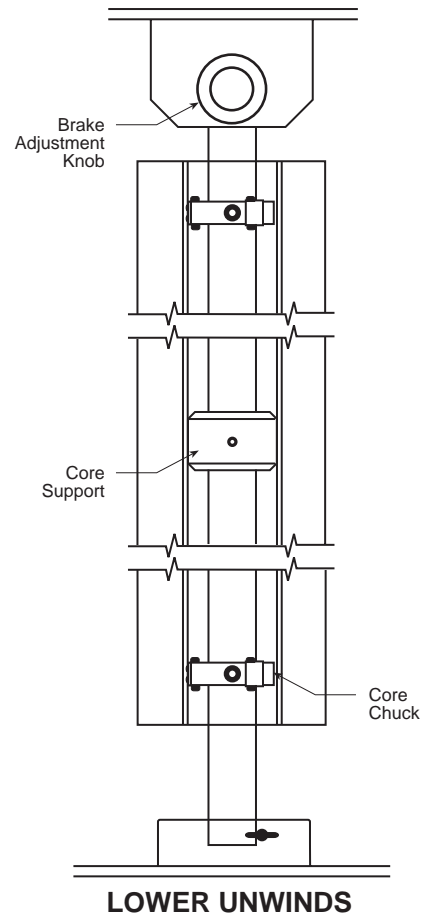

Figure 3-5: Brake Configuration

Process Control Charts

Process control charts allow you to record the way you thread film through the machine's rolls and idlers (called webbing) and the control settings for each product and process. Process control charts are an excellent tool for training new operators. They provide a "road map" for correct machine setup and operation.

This section contains a blank process control chart and diagram for the ORCA-I SP and completed charts for the basic operations of the laminator.

GBC Pro-Tech laminators respond in a very accurate and repeatable manner. The charts provide a way to set up each time, every time for repeatable performance by assuring that all controls are set to optimum.

The process control charts should be kept in this manual or in a book close to the laminator. Use the machine to encapsulate the popular charts to protect them.

NOTE

When trying new products and processes, remember that GBC Pro-Tech's customer service representatives are only a phone call away. In North America, please call 1-800-236-8843.

The completed process control charts included in this section are based on Orca-Film and typical prints.



WARNING

The blades on the slitters are razor sharp. You can cut yourself severely.

Mounting Only

Setup

1. See process charts 3-1 and diagram 3-1a.
2. Set the controls as follows:
 - Shims: Set to the thickness of the material being used for mounting.
 - Main Roll Air Pressure: 40 psi (275 kPa).
 - Speed Adjust: 3 fpm (1 m/min).
 - Upper Heater Controller: 220°F (104 °C).

Procedure

1. Lay the print on the board. Using a tack iron, tack the leading edge of the print down onto the board so it is held in place.
2. Put a piece of contact/release paper over the print and board to protect the laminating roll from contact with the adhesive, which can cause damage, and to prevent deposits of electrostatic print ink on the roll.
3. Feed the print/board package through the nip.

Mounting/Laminating

The following procedure is for one-step mounting and heat-activated laminating using mounting board with one adhesive side.

Setup

1. See process chart 3-2 and diagram 3-2a.
2. Mount the film and web as shown in diagram 3-2a.
3. Set the controls as follows:
 - Shims: Set the two front shim dials to the substrate thickness.
 - Main Roll Air Pressure: 40 psi (275 kPa).
 - Speed Adjust: 3 fpm (1 m/min).
 - Upper Heater Controller: 220°F (104 °C).

Procedure

1. Lay the print on the board. Using a tack iron, tack the leading edge of the print down onto the board so it is held in place.
2. Feed the print/board package through the nip.

Encapsulation

Setup

1. See process chart 3-3 and diagram 3-3a.
2. Set the controls as follows:
 - Shims: 0
 - Main Roll Air Pressure: 60-80 psi (413-550 kPa).
 - Pull Roll Clutch Air Pressure: 60-80 psi (413-550 kPa).
 - Pull Roll Up/Down: Down
 - Pull Roll Air Pressure: 60-80 psi (413-550 kPa).
 - Speed Adjust: 3-8 fpm (0.9-2.4 m/min).
 - Upper Heater Controller: 220 °F (104 °C).
 - Lower Heater Controller: 220 °F (104 °C).
 - Cooling Fan: Off.
 - Use of the rear wind-up roll for the finished material is optional. It is a good procedure for long runs.

Procedure

Feed the work into the nip with the leading edge tight and entering the nip evenly from side to side. For thin paper from electrostatic printers in roll form, it is best to fold over the leading edge approximately 6 inches to create a square leading edge.

Two-Pass Mount and Laminate (Hot and Cold)

There are several approaches to the mount/laminate task. It can be accomplished with either hot or cold laminate film on the top. Also, the second pass for mounting can be done by feeding from either the front or back of the laminator.

Setup

See process charts 3-4, 3-5, 3-6, 3-7 and diagrams 3-4a, 3-5a, 3-6a, and 3-7a for film mounting instructions and machine adjustments.

Be sure that the mounting film from the bottom side has the sticky (adhesive) side riding up around the outside of the bottom laminating roll.

Procedure, Pass 1

1. Run the print through to apply adhesive and laminate.
2. Trim to slightly larger than the desired finished size.

Procedure, Pass 2

1. Prepare to put the print through a second time to mount the print to the substrate such as wood, Masinote, Gator foam, or similar materials. Start by setting the shims to the appropriate spacing for the material used.
2. Trim the board to the size of the print.
3. Align the work to the board and ensure an exact fit. Place weights on the center of the print to make sure that it does not move relative to the board during the next steps.
4. Raise one end of the print and peel back approximately two inches of the liner to expose the adhesive that was applied to the print in the first pass. Fold it under.
5. Lay the print back down evenly and extremely flat. From the center outward, tack the exposed adhesive to the substrate.
6. Position the piece so that the end with the liner peeled back is facing the nip. Insert the first one inch of the board into the nip. Very carefully wrap the print back and over the top laminating roll. Be sure there are no wrinkles in the nip area. Carefully peel off the liner as the board progresses through the laminator.
7. Trim the piece to the finished size.

Vinyl Transfer

Setup

1. See process charts 3-8 and 3-9 and diagrams 3-8a and 3-9a.
2. Set the controls as follows:
 - Shims: 0
 - Main Roll Air Pressure: 90-120 psi (619-825 kPa).
 - Pull Roll Clutch Air Pressure: 50-80 psi (345-550 kPa).
 - Pull Roll Up/Down: Down
 - Pull Roll Air Pressure: 50-80 psi (345-550 kPa).
 - Speed Adjust: 1-3 fpm (.3-.9 m/min).
 - Upper Heater Controller: 290 °F (143 °C).
 - Lower Heater Controller: - 32 °F (0 °C).
 - Cooling Fan: Off.

Procedure, Pass 1

1. See process chart 3-8 and diagram 3-8a for material mounting instructions and machine adjustments.
2. Web the vinyl up around the bottom main roll and over to the pull roll. Make sure the material is webbed straight and lower the pull roll to hold the vinyl.
3. Web the paper through as shown in diagram 3-8a.

Often, when paper is not on a core, hand tension must be applied to the paper in order to maintain transfer quality until the end of the transferred image.

Procedure, Pass 2

1. See process chart 3-9 and diagram 3-9a for film mounting instructions and machine adjustments.
2. Trim the piece to the finished size.

PROCESS CONTROL CHART

Product: _____ Process: _____ Date: _____

Material Top: _____ Material Bottom: _____

Other Material: _____

CONTROL SETTINGS	
Speed:	Reverse/Forward:
Main Roll Up/Down:	Main Roll Pressure:
Top Heater On/Off:	Top Temp. Set:
Bottom Heater On/Off	Bottom Temp. Set:
Main Roll Shim Dials:	
Pull Roll Clutch On/Off:	Pull Roll Clutch Pressure:
Pull Roll Up/Down:	Pull Roll Pressure:
Pull Roll Shim Dials:	Cooling:

Special Instructions: _____

PROCESS CONTROL DIAGRAM

Identification Diagram

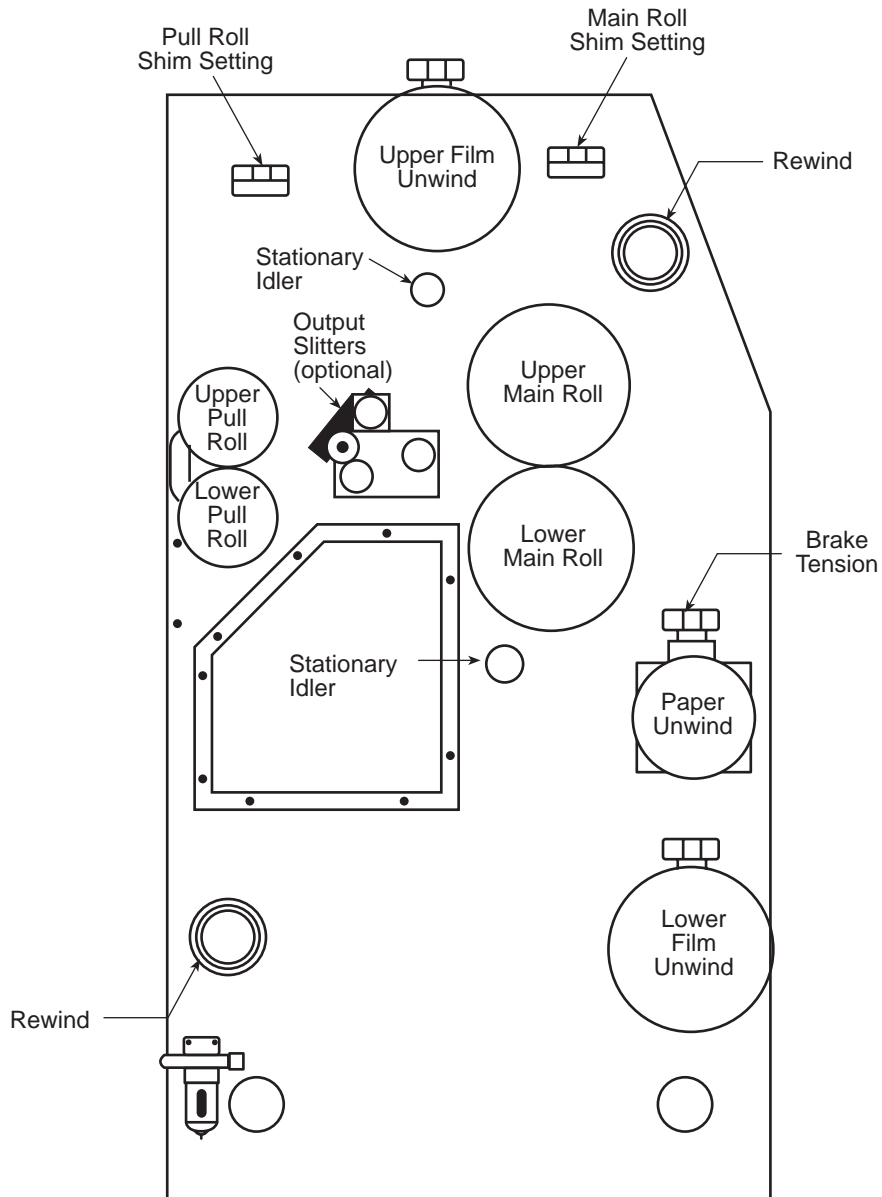

PROCESS CONTROL CHART 3-1

One Pass Mounting

Product: _____ Process: 1-Pass Mounting Date: _____

Material Top: _____ Material Bottom: 3/16 Inch Orca Board

Other Material: _____

CONTROL SETTINGS	
Speed: 3 ft/min (1 m/min)	Reverse/Forward: Forward
Main Roll Up/Down: Down	Main Roll Pressure: 40 psi (275 kPa)
Top Heater On/Off: On	Top Temp. Set: 220 °F (104 °C)
Bottom Heater On/Off: On	Bottom Temp. Set: 32 °F (0 °C)
Main Roll Shim Dials: Set to board thickness	
Pull Roll Clutch On/Off: --	Pull Roll Clutch Pressure: --
Pull Roll Up/Down: Up	Pull Roll Pressure: --
Pull Roll Shim Dials: __	Cooling: --
See Diagram 3-1A for Webbing Outline	

Special Instructions: _____

PROCESS CONTROL DIAGRAM 3-1A

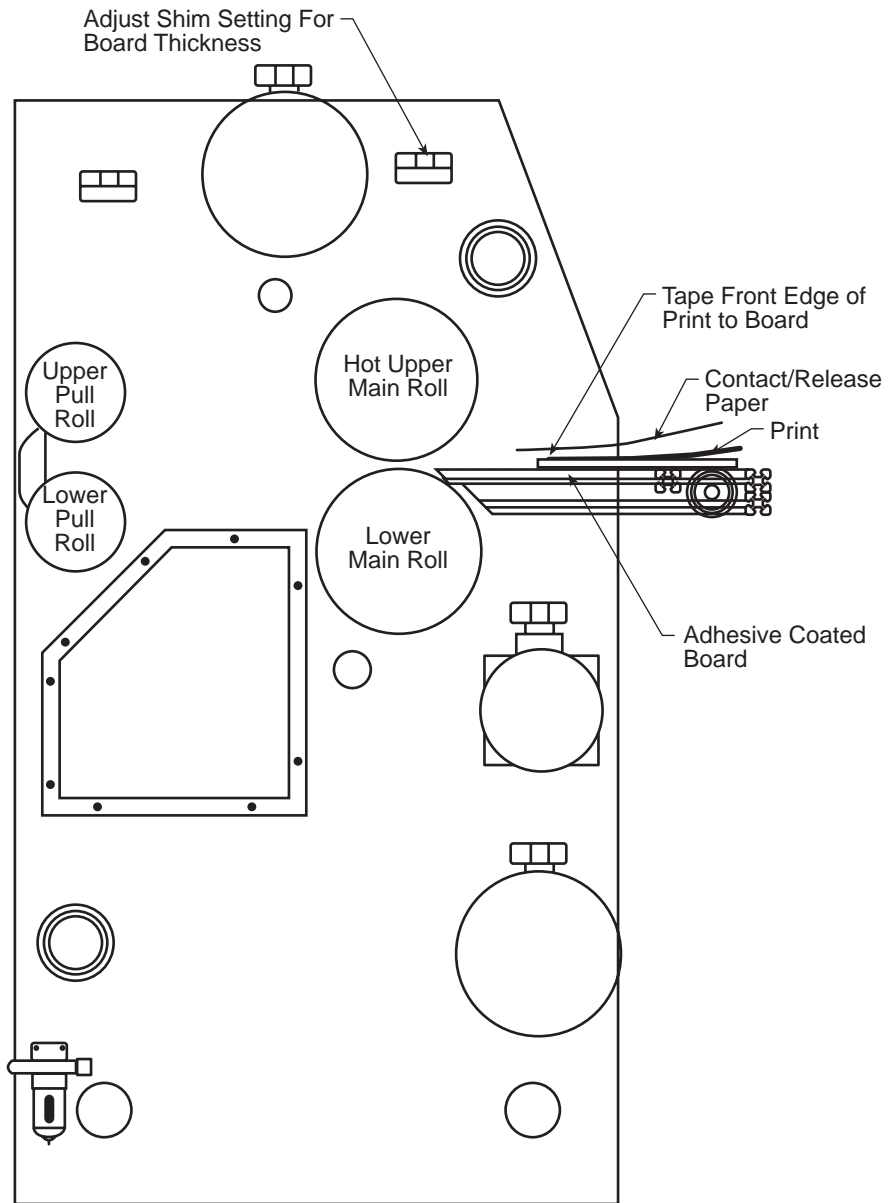

PROCESS CONTROL CHART 3-2

One Pass Mounting/Laminating

Product: _____ Process: 1-Pass Mounting/Laminating _____ Date: _____

Material Top: 3 Mil Gloss _____ Material Bottom: 3/16 Inch Orca Board _____

Other Material: _____

CONTROL SETTINGS	
Speed: 3 ft/min (1 m/min)	Reverse/Forward: Forward
Main Roll Up/Down: Down	Main Roll Pressure: 40 psi (275 kPa)
Top Heater On/Off: On	Top Temp. Set: 220 °F (104 °C)
Bottom Heater On/Off: On	Bottom Temp. Set: 32 °F (0 °C)
Main Roll Shim Dials: Set to board thickness	
Pull Roll Clutch On/Off: --	Pull Roll Clutch Pressure: --
Pull Roll Up/Down: Up	Pull Roll Pressure: --
Pull Roll Shim Dials: --	Cooling: --
See Diagram 3-2A for Webbing Outline	

Special Instructions: _____

PROCESS CONTROL DIAGRAM 3-2A

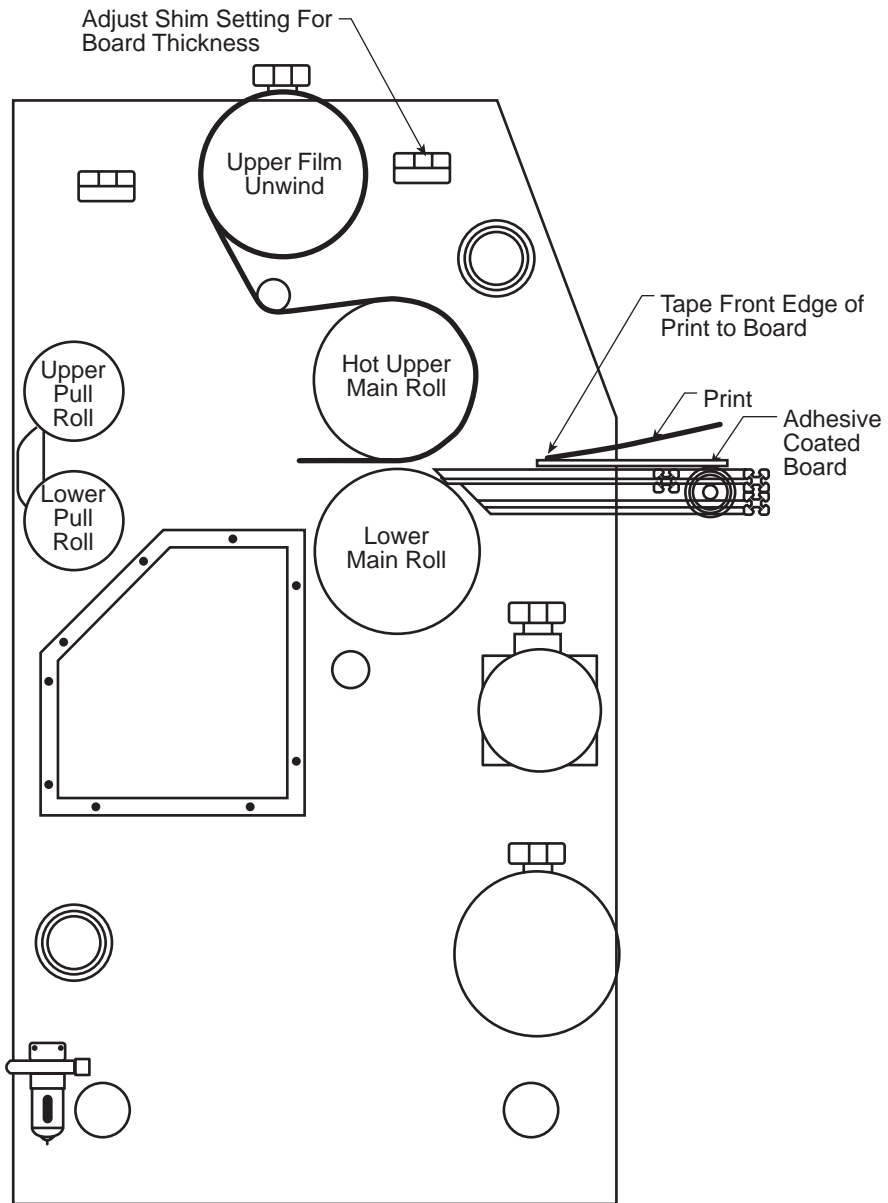

PROCESS CONTROL CHART 3-3

Encapsulation

Product: _____ Process: Encapsulation _____ Date: _____

Material Top: 3 Mil Gloss _____ Material Bottom: 3 Mil Gloss _____

Other Material: _____

CONTROL SETTINGS	
Speed: 3-8 ft/min (0.9-2.5 m/min)	Reverse/Forward: Forward
Main Roll Up/Down: Down	Main Roll Pressure: 60-80 psi (413-550 kPa)
Top Heater On/Off: On	Top Temp. Set: 220 °F (104 °C)
Bottom Heater On/Off: On	Bottom Temp. Set: 220 °F (104 °C)
Main Roll Shim Dials: 0	
Pull Roll Clutch On/Off: On	Pull Roll Clutch Pressure: 60-80 psi (413-550 kPa)
Pull Roll Up/Down: Down	Pull Roll Pressure: 60-80 psi (413-550 kPa)
Pull Roll Shim Dials: 0	Cooling: Optional
See Diagram 3-3A for Webbing Outline	

Special Instructions: _____

PROCESS CONTROL DIAGRAM 3-3A

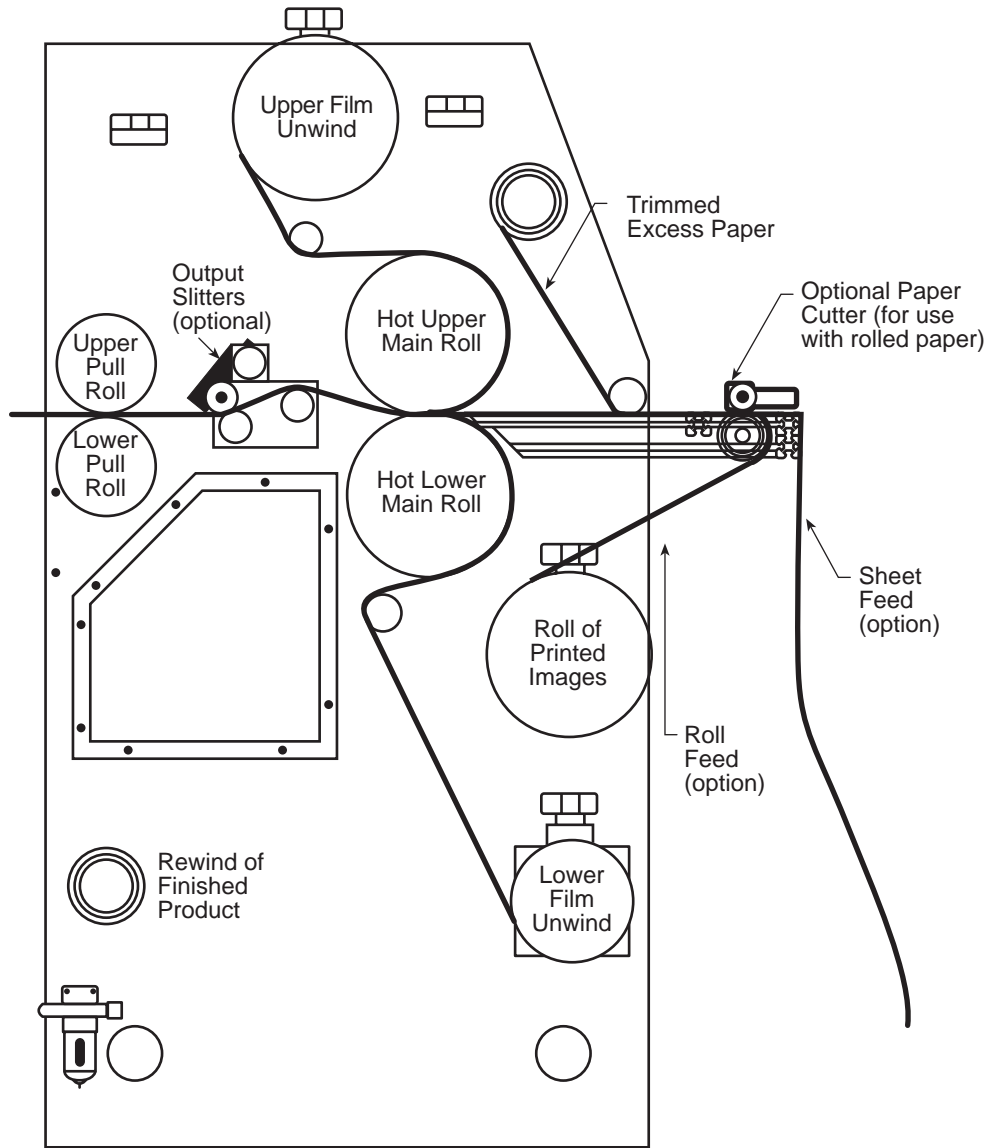

PROCESS CONTROL CHART 3-4

Two Pass Hot Laminate/Cold Mount (First Pass)

Product: _____ Process: 2-Pass Hot Laminate/Cold Mount (1st Pass) Date: _____

Material Top: 3 Mil Gloss _____ Material Bottom: Pro-Mount _____

Other Material: _____

CONTROL SETTINGS	
Speed: 4-6 ft/min (1.2-2 m/min)	Reverse/Forward: Forward
Main Roll Up/Down: Down	Main Roll Pressure: 60-80 psi (413-550 kPa)
Top Heater On/Off: On	Top Temp. Set: 220 °F (104 °C)
Bottom Heater On/Off: On	Bottom Temp. Set: 32 °F (0 °C)
Main Roll Shim Dials: 0	
Pull Roll Clutch On/Off: On	Pull Roll Clutch Pressure: 60-80 psi (413-550 kPa)
Pull Roll Up/Down: Down	Pull Roll Pressure: 60-80 psi (413-550 kPa)
Pull Roll Shim Dials: 0	Cooling: Optional
See Diagram 3-4A for Webbing Outline	

Special Instructions: _____

PROCESS CONTROL DIAGRAM 3-4A

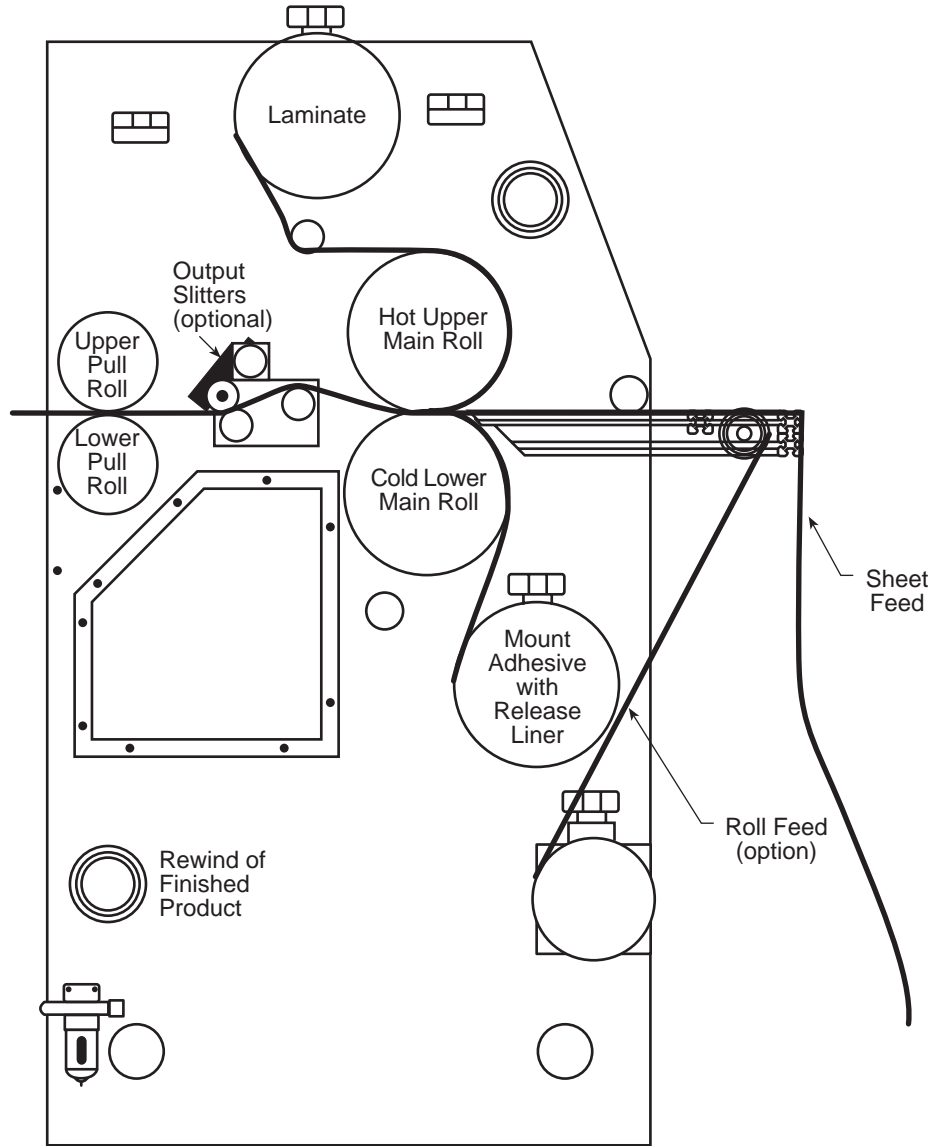

PROCESS CONTROL CHART 3-5

Two Pass Hot Laminate/Cold Mount (Second Pass)

Product: _____ Process: 2-Pass Hot Laminate/Cold Mount (2nd Pass) Date: _____

Material Top: 3 Mil Gloss _____ Material Bottom: 3/16 Foamcore _____

Other Material: _____

CONTROL SETTINGS	
Speed: 3-4 ft/min (1-1.2 m/min)	Reverse/Forward: Reverse
Main Roll Up/Down: Up	Main Roll Pressure: --
Top Heater On/Off: On or Off*	Top Temp. Set: --
Bottom Heater On/Off: On or Off*	Bottom Temp. Set: --
Main Roll Shim Dials: --	
Pull Roll Clutch On/Off: On	Pull Roll Clutch Pressure: 80 psi (550 kPa)
Pull Roll Up/Down: Down	Pull Roll Pressure: 60 psi (413 kPa)
Pull Roll Shim Dials: 3/16	Cooling: Off
See Diagram 3-5A for Webbing Outline	

Special Instructions: *For mounting with pull rolls, main rolls can remain hot _____

PROCESS CONTROL DIAGRAM 3-5A

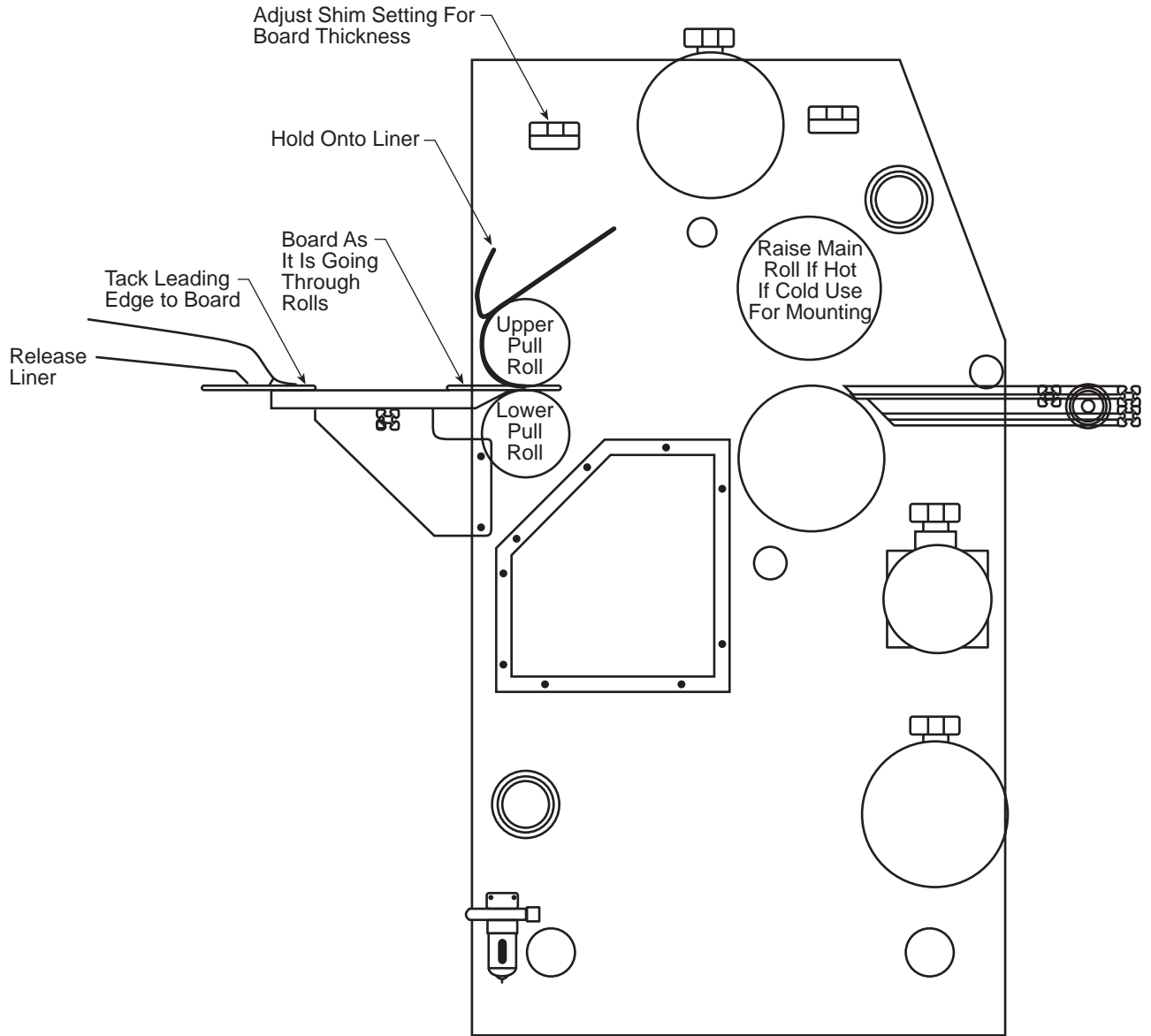

PROCESS CONTROL CHART 3-6

Two Pass Cold Mount/Cold Laminate (First Pass)

Product: _____ Process: 2-Pass Cold Mount/Cold Laminate (First Pass) Date: _____

Material Top: Pro-Gloss _____ Material Bottom: Pro-Mount _____

Other Material: _____

CONTROL SETTINGS	
Speed: 4-6 ft/min (1.2-2 m/min)	Reverse/Forward: Forward
Main Roll Up/Down: Down	Main Roll Pressure: 80 psi (550 kPa)
Top Heater On/Off: Off*	Top Temp. Set: --
Bottom Heater On/Off: Off*	Bottom Temp. Set: --
Main Roll Shim Dials: --	
Pull Roll Clutch On/Off: On	Pull Roll Clutch Pressure: 80 psi (550 kPa)
Pull Roll Up/Down: Down	Pull Roll Pressure: 60 psi (413 kPa)
Pull Roll Shim Dials: 3/16	Cooling: Off
See Diagram 3-6A for Webbing Outline	

Special Instructions: *For cold laminating, rolls can be cold or warmed to 100° F.

PROCESS CONTROL DIAGRAM 3-6A

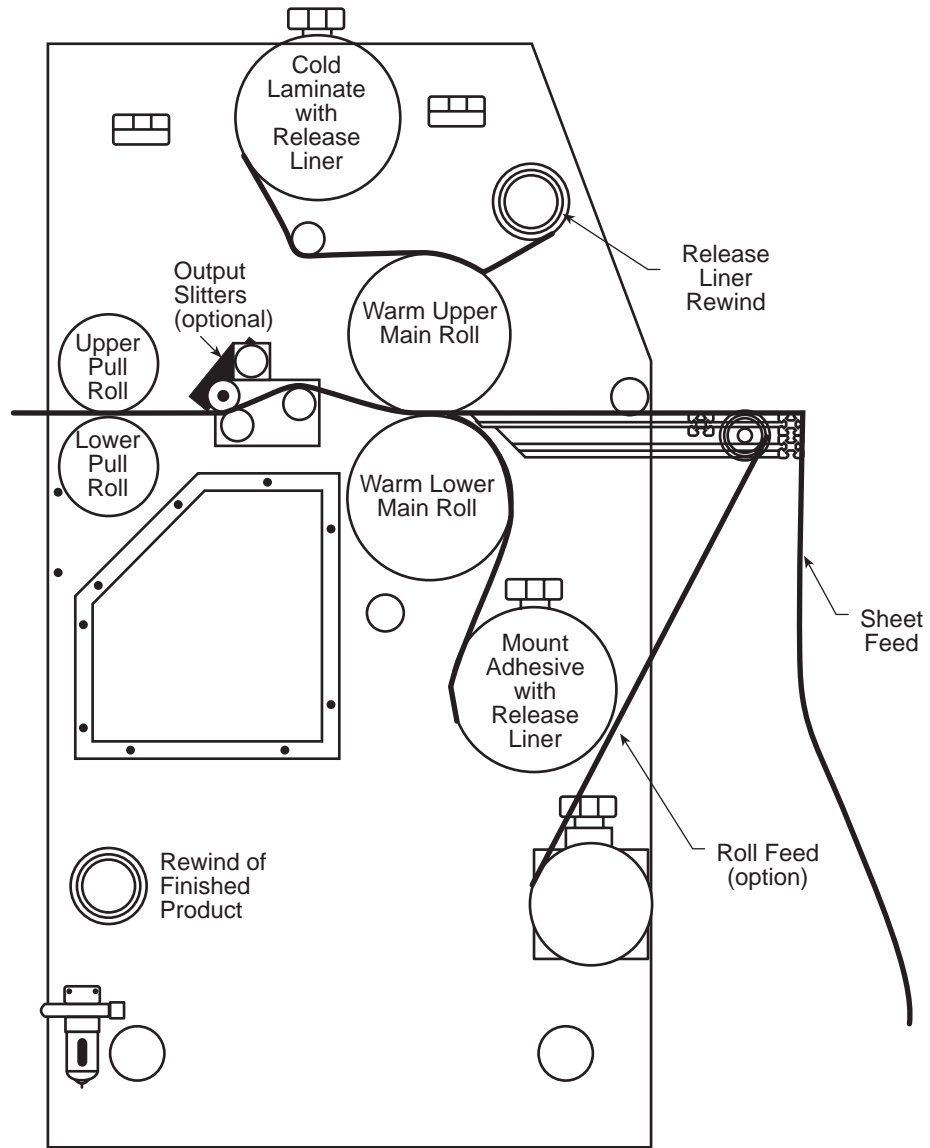

PROCESS CONTROL CHART 3-7

Product: _____ Process: 2-Pass Cold Mount/Cold Laminate (2nd Pass) Date: _____
 Material Top: _____ Material Bottom: 3/16 Foamcore _____
 Other Material: _____

CONTROL SETTINGS	
Speed: 3-4 ft/min (1-1.2 m/min)	Reverse/Forward: Reverse
Main Roll Up/Down: Up	Main Roll Pressure: --
Top Heater On/Off: Off	Top Temp. Set: --
Bottom Heater On/Off: Off	Bottom Temp. Set: --
Main Roll Shim Dials: --	
Pull Roll Clutch On/Off: On	Pull Roll Clutch Pressure: 80 psi (550 kPa)
Pull Roll Up/Down: Up	Pull Roll Pressure: 60 psi (413 kPa)
Pull Roll Shim Dials: 3/16	Cooling: Off
See Diagram 3-7A for Webbing Outline	

Special Instructions: _____

PROCESS CONTROL DIAGRAM 3-7A

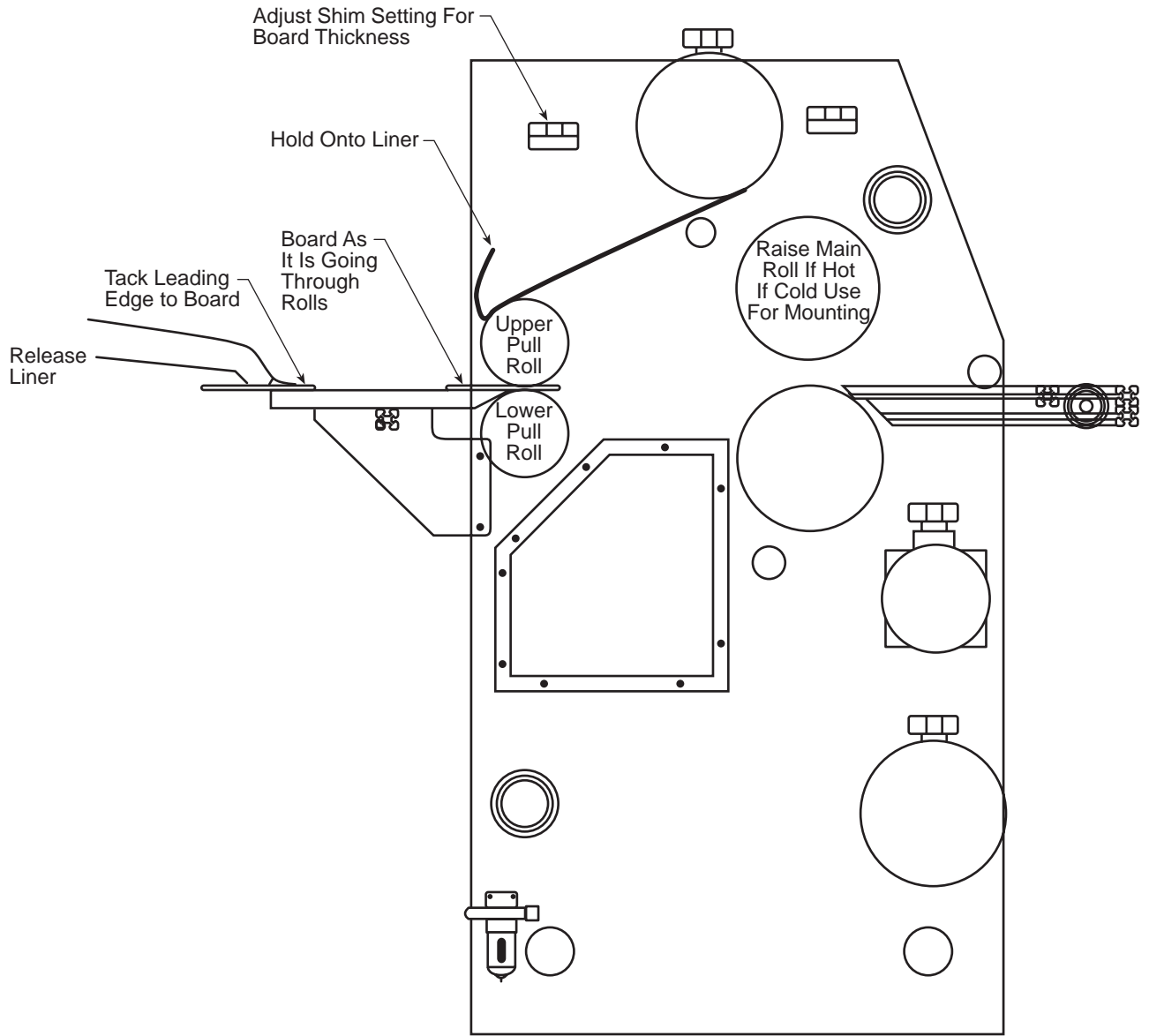

PROCESS CONTROL CHART 3-8

Vinyl Transfer (First Pass)

Product: _____ Process: Vinyl Transfer (1st Pass) _____ Date: _____

Material Top: _____ Material Bottom: _____

Other Material: _____

CONTROL SETTINGS	
Speed: 1-3 fpm (0.3-0.9 m/min)	Reverse/Forward: Forward
Main Roll Up/Down: Down	Main Roll Pressure: 90-120 psi (619-825 kPa)
Top Heater On/Off: On	Top Temp. Set: 290 °F (143 °C)
Bottom Heater On/Off: On	Bottom Temp. Set: 32 °F (0 °C)
Main Roll Shim Dials: 0	
Pull Roll Clutch On/Off: On	Pull Roll Clutch Pressure: 50-60 psi (344-413 kPa)
Pull Roll Up/Down: Down	Pull Roll Pressure: 70 psi (481 kPa)
Pull Roll Shim Dials: 0	Cooling: On
See Diagram 3-8A for Webbing Outline	

Special Instructions: _____

PROCESS CONTROL DIAGRAM 3-8A

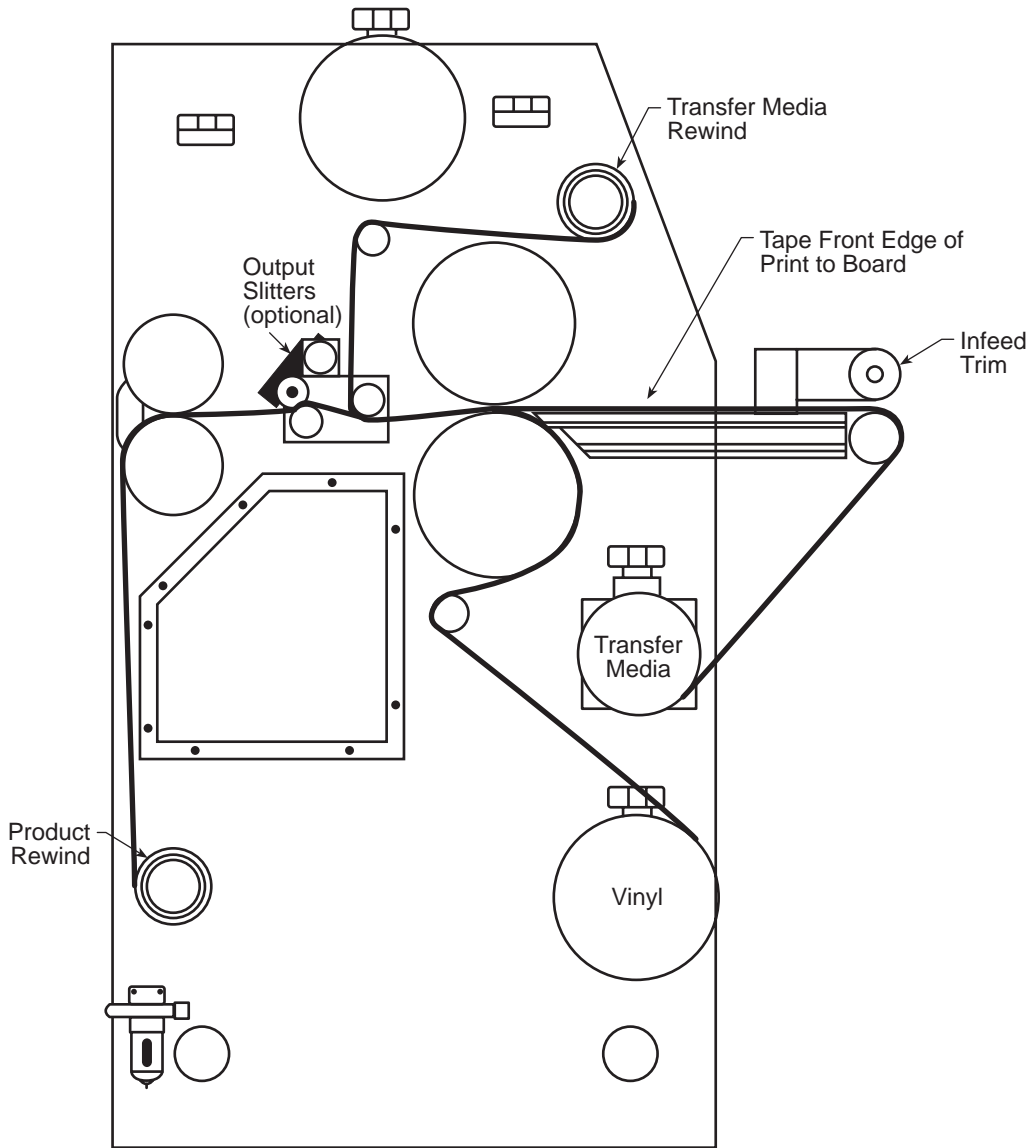

PROCESS CONTROL CHART 3-9

Product: _____ Process: Vinyl Transfer-Second Pass & Overlamine Date: _____

Material Top: _____ Material Bottom: _____

Other Material: _____

CONTROL SETTINGS	
Speed: 1-8 ft/min (0.3-2.5 m/min)	Reverse/Forward: Forward
Main Roll Up/Down: Down	Main Roll Pressure: 70-90 psi (481-825 kPa)
Top Heater On/Off: Off	Top Temp. Set: 32 °F (0 °C)
Bottom Heater On/Off: Off	Bottom Temp. Set: 32 °F (0 °C)
Main Roll Shim Dials: 0	
Pull Roll Clutch On/Off: On	Pull Roll Clutch Pressure: 50-80 psi (344-550 kPa)
Pull Roll Up/Down: Down	Pull Roll Pressure: 50-80 psi (344-550 kPa)
Pull Roll Shim Dials: 0	Cooling: No
See Diagram 3-9A for Webbing Outline	

Special Instructions: _____

PROCESS CONTROL DIAGRAM 3-9A

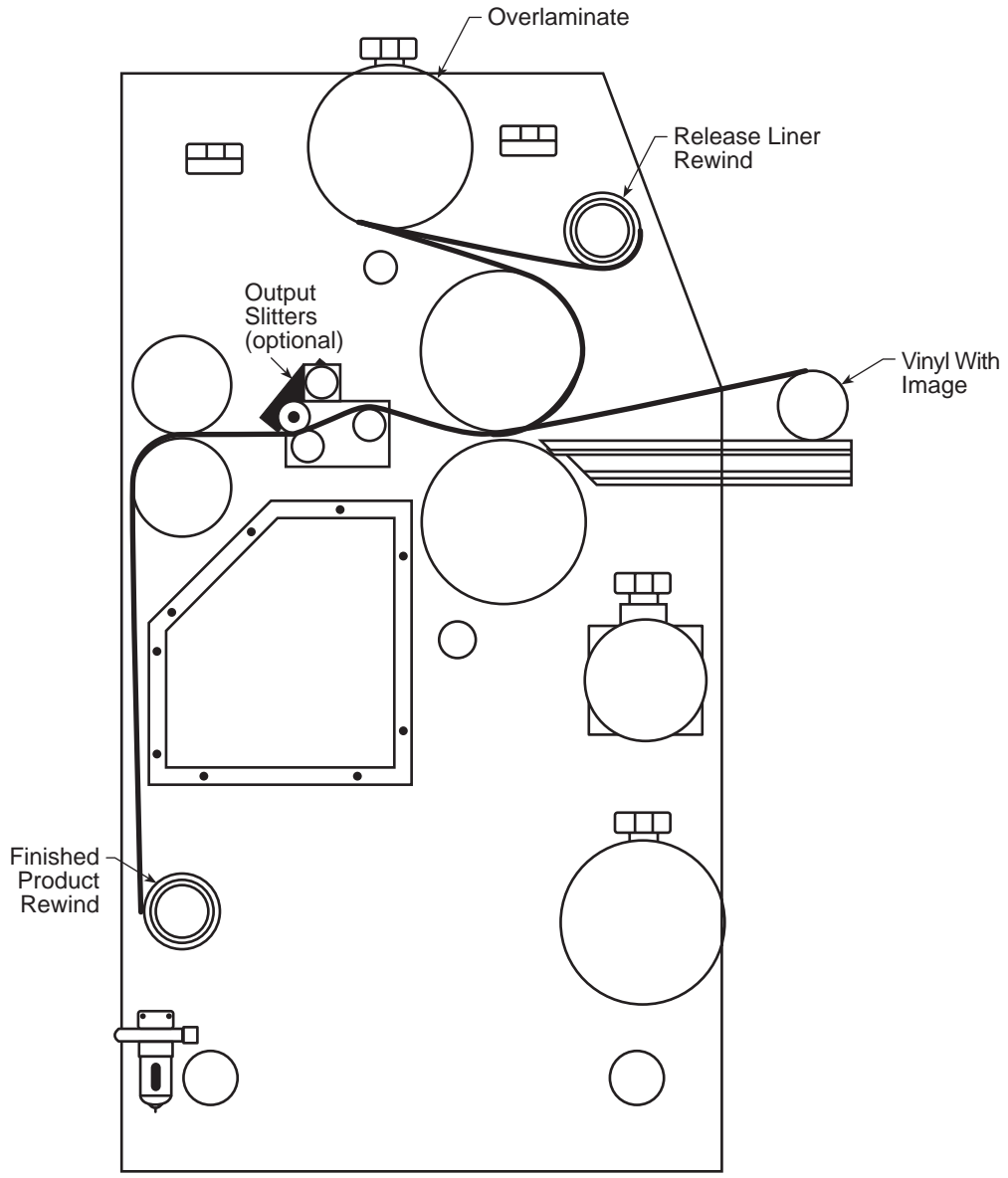

Blank page.

Section 4: Maintenance and Troubleshooting

Performing regular maintenance on the ORCA-I SP Laminator is critical to the proper operation of the machine. A maintenance schedule and a section of procedures for disassembling and reassembling the serviceable areas of the laminator are included in this section.

Table 4-1: Maintenance Schedule

Daily	<ul style="list-style-type: none"> • Clean the rolls • Check to be sure nothing is blocking the infrared sensors from reading the roll temperature • Inspect the electrical cord for damage • Inspect the footswitch cord for damage
Monthly	<ul style="list-style-type: none"> • Adjust the nip • Align/adjust the IR sensors, if necessary • Check the chain tension • Inspect the area around the laminator for possible hazards (dust buildup, combustible items stored too close, etc.) • Adjust the air cylinder rates
Every Six Months	<ul style="list-style-type: none"> • Lubricate the grease fittings and chain • Check wire termination tightness



Do not adjust or otherwise tamper with any controls, settings, trim pots, locknuts, etc., other than for the procedures described in this section. these devices are carefully pre-set at the factory and the proper procedures require specialized training and equipment.

Cleaning

Tools required:

- Adhesive coated board
- 80% isopropyl alcohol
- Rubber cement eraser
- Several lint free 100% cotton terry cloths
- Protective rubber gloves

To clean the laminator rolls:

1. Lower the infeed table and infeed pressure plate to gain access to the rolls.



Exercise extreme caution while cleaning the laminator. You can be caught in the turning rolls and crushed or burned.



The blades the slitters are razor sharp. You can cut yourself severely.

2. While the laminator is at normal operating temperature, put on the rubber gloves and use a rubber cement eraser to remove any heat activated adhesive from the rolls.



If silicone adhesive contacts the upper or lower roll, remove it IMMEDIATELY using a rubber cement eraser. It can harden within an hour and ruin the roll.



Do not use compressed air to clean the machine. Compressed air forces dust/debris into places that can damage machine operation.

**CAUTION**

Do NOT pick or pull heat activated adhesive off the rolls when they are cold. You can cause irreparable damage to the laminating rolls.

To clean beads of adhesive, dust and dirt from the rolls:

1. Allow the laminator to cool slightly to no lower than 110°F (43°C).
2. Set the FWD/REV switch to the REV position and use the footswitch to move the rolls as you clean them. Set the Speed Control to 1.5 fpm (0.5 m/min).
3. Clean the rolls using a moderate amount of 80% isopropyl alcohol on a cotton terry cloth.

**CAUTION**

Use the minimum amount of pressure necessary to clean the rolls. You can destroy the silicone layer on the rolls by pressing too hard or scrubbing too long in one spot.

**WARNING**

Exercise care when cleaning the rolls with 80% isopropyl alcohol:

- Use only in a well ventilated area.
 - Wear rubber gloves.
 - Use only on cool rolls.

Cleaning heated rolls can ignite the fumes.

**CAUTION**

Use only 80% isopropyl alcohol or a rubber cement eraser to clean the laminating rolls. Harsh chemicals like toluene, acetone or MEK destroy the silicone covering of the rolls.

4. With the laminator rolls no hotter than 110°F (43°C), remove dust and dirt from the silicone laminating rolls by running an adhesive-coated board through the laminator. Be sure to set the nip for the thickness of the board used.
5. Allow the laminator to cool.

To clean the cabinet and covers:**WARNING**

Remove power from the laminator and make sure it cannot be reapplied while you are performing this procedure. You could be severely shocked, be electrocuted, or get your fingers caught in the drive mechanisms.

Using a damp cotton terry cloth (water only), clean the exterior of the laminator.

**WARNING**

Do not use liquid or aerosol cleaners on the laminator. Do not spill liquid of any kind on the laminator. You can be severely shocked, be electrocuted, or cause a fire. Use only a damp cloth for cleaning the exterior.

Adjusting the Nip

The gap between the two main rolls is called the nip. The purpose of adjusting the nip is to ensure continuous contact between the laminating rolls as the media is drawn through the machine. This procedure must be done regularly.

Tools required:

- 1/8" hex wrench
- 7/64" hex wrench

To adjust the main roll nip:



DANGER

EXERCISE EXTREME CAUTION WHEN REMOVING THE CABINET COVERS WHILE THE LAMINATOR IS OPERATIONAL! You can be severely shocked or electrocuted.

1. Remove the drive and control side cabinet covers by removing the screws with the 1/8" hex wrench.
2. Turn the **UP-DOWN** switch on the front control panel to the **UP** position to raise the main roll.
3. Loosen the 7/64" screw in the upper black lock collar located at the top of the cylinder shaft on the control side of the laminator.

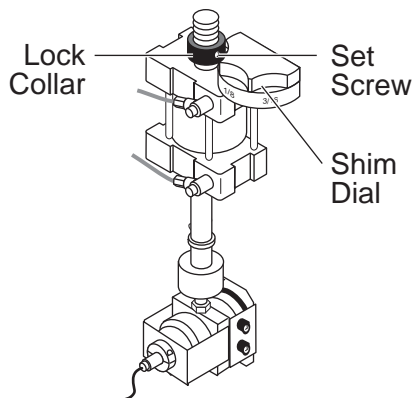

Figure 4-1: Adjusting the Nip

4. Turn the lock collar up several turns to allow the upper main roll to rest on the lower main roll when lowered.
5. Set the shim dial to zero (0).
6. Repeat steps 3-5 for the laminator's drive side.
7. Set the main roll pressure to 30-40 psi (205-275 kPa).
8. Turn the **UP-DOWN** switch on the front control panel to the **DOWN** position to lower the upper main roll. Allow it to settle for approximately 10 seconds.



CAUTION

The nip area must be clear of obstructions before you lower the upper main roll to ensure that the rolls contact properly.

9. Spin both lock collars down until they are just touching the shim dials. The dials should not be able to move up or down when each collar is tight.
10. Tighten the set screw in each lock collar.
11. Replace both cabinet covers.

To adjust the pull roll nip

1. Remove the drive and control side cabinet covers by removing the screws with a 1/8" hex wrench.
2. Turn the **PULL ROLL UP-DOWN** switch on the rear control panel to the **UP** position to raise the upper pull roll.
3. Loosen the 7/64" screw in the upper black lock collar located at the top of the pull roll cylinder shaft on the control side of the laminator.

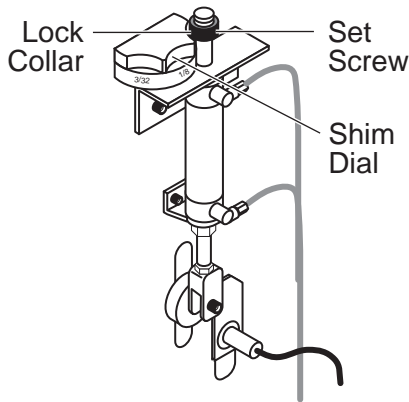

Figure 4-2: Adjusting the Pull Roll Nip

4. Turn the lock collar up several turns to allow the upper pull roll to rest on the lower pull roll when lowered.
5. Set the shim dial to zero (0).
6. Repeat steps 3-5 for the pull roll cylinder shaft on the laminator's drive side.
7. Set the pull roll pressure to 40 psi.
8. Turn the **UP-DOWN** switch on the rear control panel to the **DOWN** position to lower the upper pull roll. Allow it to settle for approximately 10 seconds.



CAUTION

The nip area must be clear of obstructions before you lower the upper pull roll to ensure that the rolls contact properly.

9. Spin both lock collars down until they are just touching the shim disks. The disks should not be able to move up or down when each collar is tight.
10. Tighten the set screw in each lock collar.
11. Replace both cabinet covers.

Adjusting the Pressure Booster



WARNING

If the air supply pressure exceeds the typical 100 psi (700 kPa), the pressure booster must be adjusted when the air supply is installed to avoid damage to the machine and possible injury to service technicians.

Do not perform this adjustment if the air supply pressure is the typical 100 psi.

Do not use an incoming air supply that exceeds 120 psi (825 kPa).

1. Before installing an incoming air supply that is greater than 100 psi (700 kPa) and less than 120 psi (825 kPa), close the pressure booster by gently pulling out on the pressure booster regulator knob and rotating it counterclockwise as far as possible. See the figure below for the location of the knob.

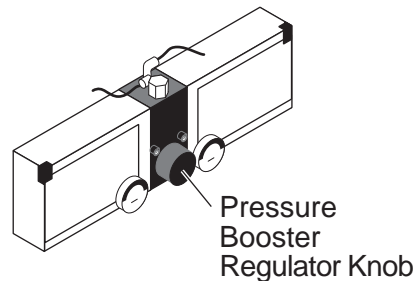

Figure 4-3: Pressure Booster Adjustment

2. Pull out the main roll air pressure control knob and rotate it fully clockwise.
3. Install the incoming air supply to the filter outside the electrical end cabinet.

4. Turn the pressure booster regulator knob clockwise until the main roll air pressure gauge reaches 150 psi (1030 kPa).
5. Use the main roll air pressure control to set the air pressure to the required level.

**WARNING**

The pressure booster cycles several times during this process. Make sure that the main roll pressure gauge does not exceed 150 psi (1030 kPa) at any point. Pressures over 150 psi can damage the electric air valves.

Chain Tensioning

Smaller chain tensioning adjustments on the ORCA-I SP laminator are handled by the automatic and secondary chain tensioners; however, when installing a new chain or when the chain tension is more seriously out of adjustment, use the following procedure to adjust the chain tension.

Tools required:

- 1/8" hex wrench
- 3/16" hex wrench
- Screwdriver

To adjust the primary chain tension:**WARNING**

Remove power from the laminator and make sure it cannot be reappplied while you are performing this procedure. You could be severely shocked, be electrocuted, or get your fingers caught in the drive mechanisms.

1. Remove the drive side cabinet cover by removing the screws with the 1/8" hex wrench.
2. Move the automatic chain tensioner off the chain.
3. Loosen but do not remove all four motor mount bolts using the 3/16" hex wrench as shown in the figure below. The motor should just move freely within the slots.

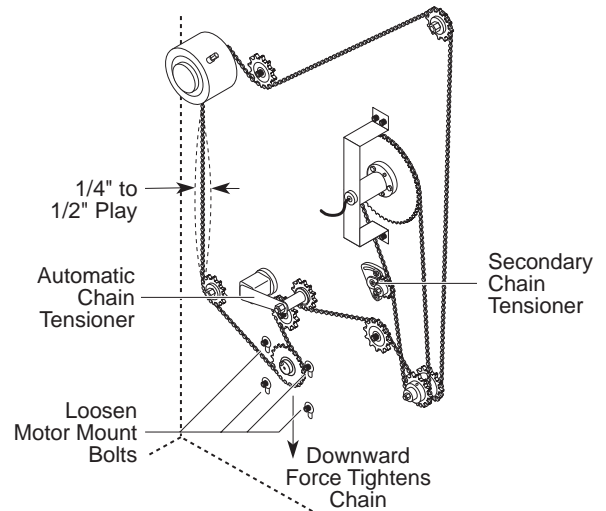

Figure 4-4: Adjusting the Chain Tension

4. Using a screwdriver, apply a small amount of downward pressure on the motor by prying against the inside of the side frame until there is 1/4" to 1/2" play in the chain.
5. Tighten the mounting bolts while maintaining the downward pressure on the motor.
6. Move the automatic chain tensioner back onto the chain.
7. Replace the cabinet cover and reapply power to the laminator.

To adjust the secondary chain tension:**WARNING**

Remove power from the laminator and make sure it cannot be reapplied while you are performing this procedure. You could be severely shocked, be electrocuted, or get your fingers caught in the drive mechanisms.

Adjust the secondary chain tensioner (see Figure 4-4) so that there is ¼" to ½" play in the secondary chain.

Adjusting the Air Cylinder Rate

If the top main roll or top pull roll move up or down unevenly, the air cylinder flow controls need to be adjusted (see Figure 4-5).

To adjust the air cylinder rate for the main rolls:

1. Make sure there is both air and power to the machine.
2. Remove both cabinet covers.
3. Loosen the large knurled locking rings.
4. Turn the main roll air cylinder adjustment valve knobs on both sides to their fully in position and mark them with a permanent marker to provide an indicator. Do not jam shut; finger tight is sufficient.
5. Rotate the upper main air cylinder adjustment knobs out 5 turns. Rotate the lower main air cylinder adjustment knobs out 3 turns.
6. The upper knob adjusts the up rate of the roll and the lower knob adjusts the down rate of the roll. Turn clockwise to reduce the rate of travel and counterclockwise to increase the rate of travel.
7. Lower and raise the roll. The roll should fall and rise evenly. If not, adjust the appropriate knobs until the rates are even.
8. Lock settings in place by tightening the large knurled locking rings.
9. Replace the cabinet covers if no further adjustments are needed.

To adjust the air cylinder rate for the pull rolls:

The adjustment procedure for the pull rolls is similar to the adjustment procedure for the main rolls.

1. Make sure there is both air and power to the machine.
2. If necessary, remove both cabinet covers.
3. Loosen the large knurled locking rings.
4. Turn the pull roll air cylinder adjustment valve knobs on both sides to their fully in position and mark them with a permanent marker to provide an indicator. Do not jam shut, finger tight is sufficient.
5. Rotate the pull roll air cylinder adjustment knobs out 3 turns. Rotate the lower pull roll cylinder adjustment knobs out 2 turns.
6. As with the main rolls, the pull roll should rise and fall evenly. If it does not, adjust accordingly.
7. Lock settings in place by tightening the large knurled locking rings.
8. Replace the cabinet covers if no further adjustments are needed.

**WARNING**

Do not adjust or otherwise tamper with any controls, settings, trim pots, locknuts, etc., other than for the procedures described in this section. These devices are carefully pre-set at the factory and the proper procedures require specialized training and equipment.

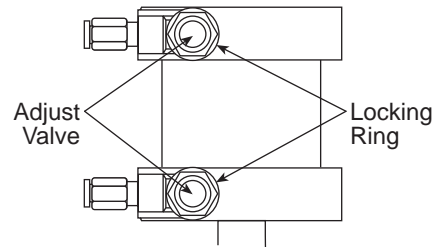

Figure 4-5: Adjusting the Air Cylinder Flow Controls

Lubrication

Tools required:

- 1/8" hex wrench
- High temperature grease or lithium grease
- Grease gun
- Soft cloth
- Automotive oil

To lubricate the laminator:



WARNING

Do not lubricate the laminator when it is hot. You can be burned.



WARNING

Remove power from the laminator and make sure it cannot be reapplied while you are performing this procedure. You could be severely shocked, electrocuted, or get your fingers caught in the drive mechanisms.

1. Remove the drive and control side cabinet covers using the 1/8" hex wrench by removing the screws that hold the cover in place.
2. Using the grease gun, lubricate each grease fitting (shown in Figure 4-5) with one squirt of high temperature grease.

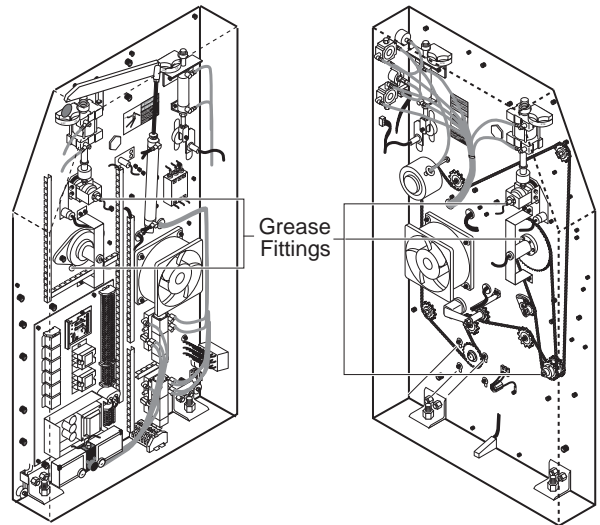

Figure 4-6: Grease Fittings

3. Lubricate the chain using a soft cloth and automotive oil.
4. Replace the cabinet covers and reapply power to the laminator.

Contacting Technical Support

For machine parts and technical service in North America, please call: 1-800-790-7787. **Please provide serial number when calling for service.** In Europe, please call: +44 (0) 1844 202 440 or fax: +44 (0) 1844 202 441.

For film and application questions in North America, please call 1-800-236-8843. In Europe, please call: +44 (0) 1844 202 440 or fax: +44 (0) 1844 202 441.

Output Troubleshooting Guide

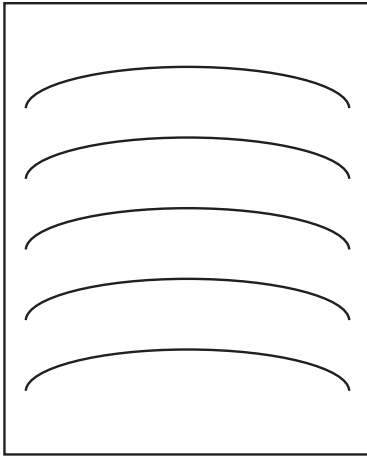

Problem:
D waves in the image, not in the laminate.

Hints:

- Check paper tension.
- Check relative moisture content of the paper.

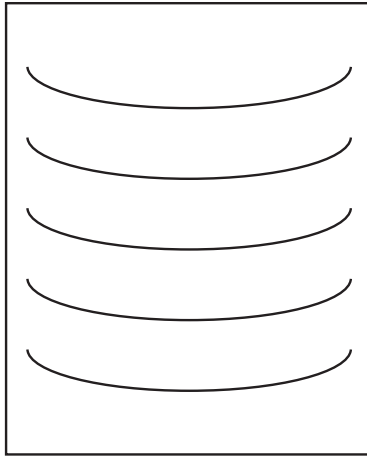

Problem:
D waves in the laminate.

Hints:

- Increase clutch tension.
- Check roll pressures.
- Check nip settings.

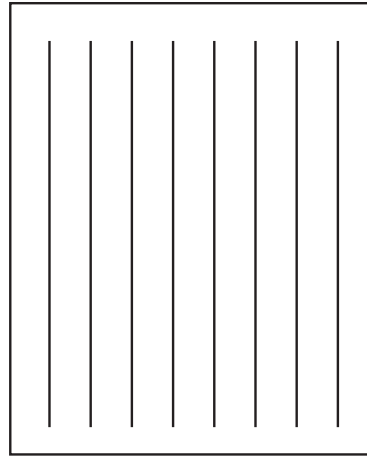

Problem:
Straight waves in the output.

Hints:

- Decrease clutch tension.
- Check operational settings for materials being used.

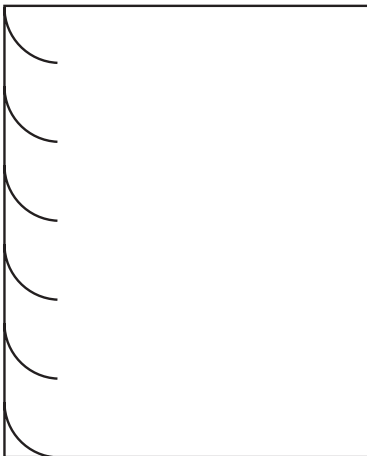

Problem:
Waves on only one side of the output.

Hints:

- Check nip settings.
- Check for even paper tension.

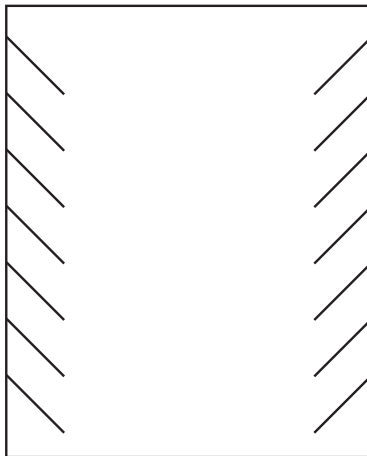

Problem:
Angled waves on the output.

Hints:

- Check for insufficient clutch tension.
- Check for insufficient main roll pressure



Other Common Problems:

Problem:
Blistering in the image.

Hints:

- Increase speed or lower the operating temperature.

Problem:
Coiling of encapsulated images.

Hints:

- Balance the upper and lower unwind brake tension. Make sure main roll temperatures are the same. Adjust cooling fans.

Problem:
Longitudinal waves or stuttering, jerking, or excessive noise from the drive side of the laminator.

Hints:

- Increase chain tension, decrease unwind brake tension.

Section 5: Warranty

Limited Warranty

GBC Pro-Tech Engineering Company, Inc. warrants the equipment sold is free from defects in material and workmanship for a period of one year **from the date of delivery** to the customer. This warranty is the only warranty made by GBC Pro-Tech and cannot be modified or amended.

GBC Pro-Tech's sole and exclusive liability and the customer's sole and exclusive remedy under this warranty shall be, at GBC Pro-Tech's option, to repair or replace any such defective part or product. These remedies are only available if GBC Pro-Tech's examination of the product discloses to GBC Pro-Tech's satisfaction that such defects actually exist and were not caused by misuse, neglect, attempt to repair, unauthorized alteration or modification, incorrect line voltage, contaminated air supply, or by fire, accident, flood, or other hazard.

This warranty specifically does not cover damage to the laminating rollers caused by knives, razor blades, other sharp objects, failure caused by adhesives or improper use of the machine. Warranty repair or replacement does not extend the warranty beyond the initial period from the date of delivery.



CAUTION

Unauthorized customer alterations will void this warranty.

THE WARRANTY MADE HEREIN IS IN LIEU OF ALL OTHER WARRANTIES, EXPRESS OR IMPLIED, INCLUDING ANY WARRANTY OR MERCHANTABILITY OR FITNESS FOR A PARTICULAR PURPOSE. GBC PRO-TECH WILL NOT BE LIABLE FOR PROPERTY DAMAGE OR PERSONAL INJURY (UNLESS PRIMARILY CAUSED BY ITS NEGLIGENCE), LOSS OF PROFIT OR OTHER INCIDENTAL OR CONSEQUENTIAL DAMAGES ARISING OUT OF THE USE OR INABILITY TO USE THE EQUIPMENT.

Exclusions to the Warranty

This warranty specifically does not cover:

1. Damage to the laminating rollers caused by knives, razor blades, other objects that contact the rollers, neglecting to clean the laminator, overheating the rolls, and failure caused by adhesives.
2. Damage to the machine caused by lifting, tilting, and/or any attempt to position the machine other than rolling on the installed casters on even surfaces.
3. Damage to the machine caused by improper use of the machine.
4. Damage to the machine caused by improper pressure booster adjustment or failure to adjust the pressure booster for an incoming air pressure that exceeds 100 psi as directed in *Adjusting the Pressure Booster* under Section 4: Maintenance and Troubleshooting.
5. Damage to the machine caused by exceeding the specifications for maximum incoming air pressure, 120 psi (825 kPa).

Blank page.

Section 6: Specifications

Table 6-1: ORCA-I SP Laminator Specifications

Characteristic	Specifications
Dimensions (L x D x H)	75" x 37" x 56" (1.91 x .94 x 1.42 m)
Weight	Uncrated: 1425 lbs (646 kg) Crated: 1775 lbs (805 kg)
Laminating Rolls	61" (155 cm) roll face with high release surface, upper and lower rolls internally heated
Laminating Opening	1.5" (3.8 cm) maximum opening
Laminating Material	Uses heat activated and pressure-sensitive materials 0 - 55" (0 - 140 cm) wide on a 3" (7.6 cm) ID core, 10" (25.4 cm) maximum diameter
Laminating Speeds	0 to 14 fmp (0 to 4.3 mpm) with variable speed, reversible action, start and stop controlled either through the instrument panel or with the footswitch
Encapsulating Features	Pull rolls and cooling fans for uniform flat cooling
Safety Features	<ul style="list-style-type: none"> • Photoelectric eyes prevent laminating roll movement if objects are in the nip area • All electrical and moving mechanical parts are located in bolted cabinets • 2 emergency stop buttons • 2 emergency kick cables
Standard Features	Outfeed Slitters
Options	Outfeed Table
Installation Requirements	USA: 220-240 VAC, 50/60 Hz, 55A, single phase 3 wire. Europe: 230/400 VAC, 3-N phase, 50 Hz, 25A per phase. Max. Air Pressure: 120 psi (825 kPa). Min. Air Pressure: 2 cfm at 100 psi (0.5 m ³ at 700 kPa). Warning: if air supply exceeds 100 psi and is less than 120 psi, the pressure booster must be adjusted.

Blank page.

Section 7: Index**A**

Air cylinder rate
Main roll 4-6
Pull roll 4-6

C

Chain
Lubrication 4-7
Tensioning 4-5
Cleaning 4-1
Clutch
Common problems 4-8
Controls
Front control panel 3-3

E

Emergency stop buttons 1-2, 2-6, 3-1
Encapsulating 6-1
Environment 2-1

F

Foot bolt 2-4
Footswitch 1-1, 2-6, 3-1, 4-1, 6-1

G

Grease fittings 4-7

H

Heater 2-6
Controller 2-6

I

Infrared sensors 2-5, 2-6, 4-1
Installation requirements 2-1, 6-1
Isopropyl alcohol 4-1

L

Laminating material 6-1
Laminating opening 6-1
Laminating rolls 6-1
Laminating speeds 6-1
Lubrication 4-7

M

Main rolls 4-3

Maintenance schedule 4-1
Motor 2-6

N

Nip 1-1, 2-5, 2-6, 3-1, 4-1, 4-3, 6-1
Main roll, adjusting 4-3

O

Outfeed slitters 6-1
Outfeed table 6-1

P

Photoelectric eye 1-1, 2-6, 3-1
Power cord 2-1
Preinstallation checklist 2-1
Pressure Booster 4-4
Pull rolls 4-4

R

Riggers 1-3, 2-4, 2-5
Roll to roll transfer 3-9
Rubber cement eraser 4-1

S

Safety features 6-1
Safety information 1-1
Safety labels 1-5
Setup procedure 2-5
Specifications
Dimensions 6-1
Encapsulating 6-1
Laminating material 6-1
Laminating opening 6-1
Laminating rolls 6-1
Laminating speeds 6-1
Weight 6-1

T

Technical support
Call 1-800-236-8843 4-7

U

Unpacking 2-4
Crate 2-4
Upper main roll 4-3
Upper pull roll 4-4

V

Vacuum table 6-1

W

Warnings and cautions 1-1

Warranty 5-1