



FALCON 60+(-1) CE

INSTALLATION & OPERATION MANUAL

Document Number: 930-108 REV DATE: 06-9-04

©2004 GENERAL BINDING CORPORATION ALL RIGHTS RESERVED.

Do not duplicate without written permission.

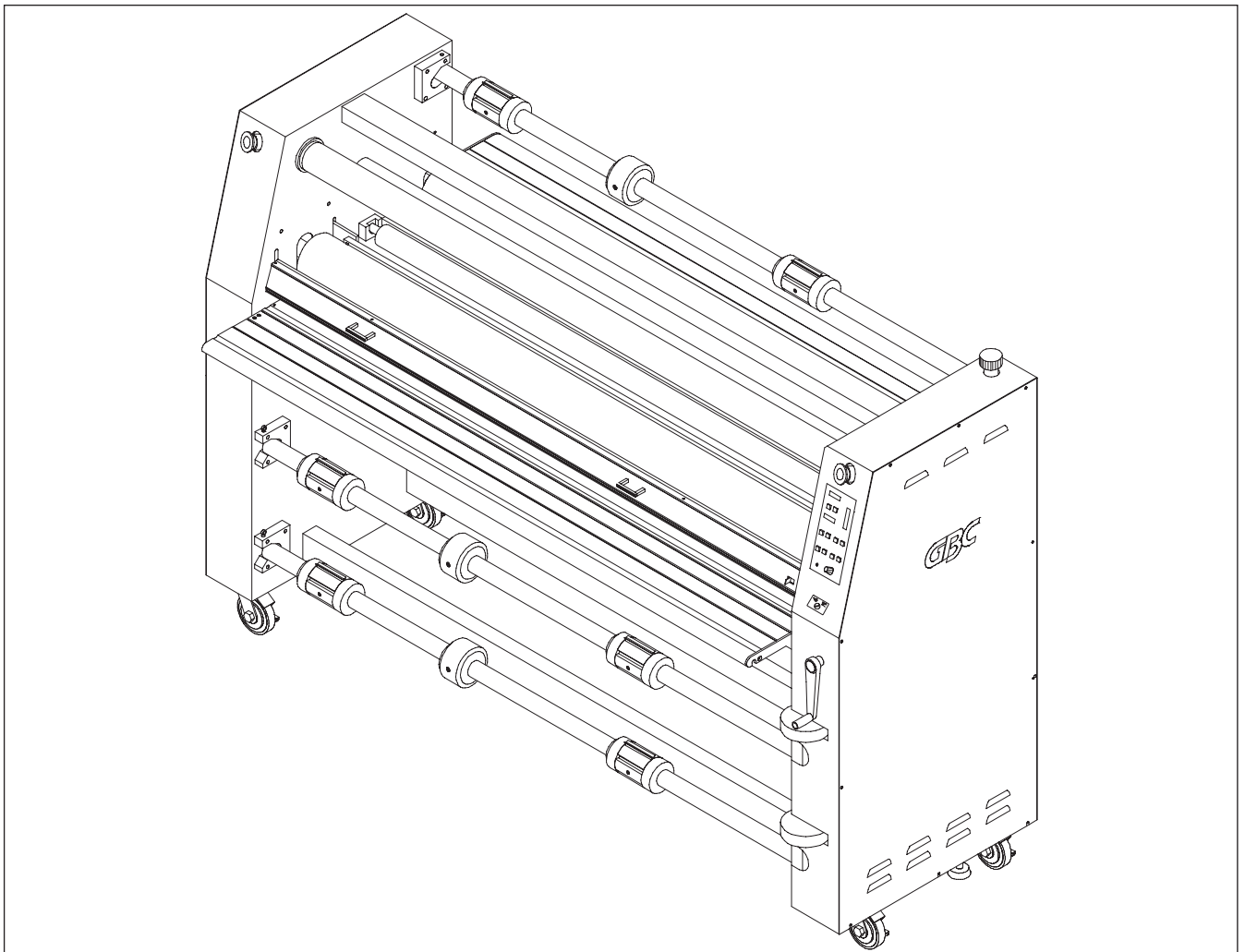

Table of content

Cover	1	Nip Point.....	21
Table of Content	3	Rear Slitter	21
Important Safety Instructions	5	Separator Bar.....	21
Important Safeguards	7	Operating Instructions	23
General	7	Film Loading and Threading	23
Electrical	7	Webbing Thermal Film	24
Service	7	Webbing PSA Film	25
Warranty	9	Start Laminating.....	26
Specifications	11	Tacking New Film.....	27
Pre-Installation	13	Unweb the Laminator.....	28
Installation	15	Clearing a Film Jam	28
Features Guide	17	Applications	29
Power Switch	17	Mounting Pre-Coated Boards	29
Control Panel Indicators.....	17	Single Sided Lamination	29
Control Panel Buttons	17	Accushield.....	31
E-Stop	18	Custom Application #1	31
Safety Shield Interlock Latch	18	Custom Application #2.....	31
Safety Shield.....	19	The Art Of Lamination	33
Feed Table	19	Basic Rules	33
Chill Idler	19	Film Tension.....	33
Film Shaft.....	19	Heat	34
Main Rollers	19	Output	34
Idler Bar	19	Maintenance	35
Pull Rollers	19	Caring for the Falcon 60+ (-1).....	35
Rewind Tube	19	Troubleshooting Guide	37
Film Shaft Brake	20	Service Agreement	37
Core Adapters.....	20		
Center Core Support.....	20		
Rewind Brake.....	20		
Main Roller Crank Handle.....	20		
Pull Roller Crank Handle.....	20		
Cooling Fans	20		
Clutch	20		
Accelerator Footswitch.....	21		
Rear Table Latches	21		
Rear Table.....	21		
Rear Run/ Stop Switch.....	21		
Film Web	21		

Important Safety Instructions

YOUR SAFETY AS WELL AS THE SAFETY OF OTHERS IS IMPORTANT TO GBC. IN THIS INSTRUCTION MANUAL AND ON THE PRODUCT, YOU WILL FIND IMPORTANT SAFETY MESSAGES REGARDING THE PRODUCT. READ THESE MESSAGES CAREFULLY. READ ALL OF THE INSTRUCTIONS AND SAVE THESE INSTRUCTIONS FOR LATER USE.



THE SAFETY ALERT SYMBOL PRECEDES EACH SAFETY MESSAGE IN THIS INSTRUCTION MANUAL. THE SYMBOL INDICATES A POTENTIAL PERSONAL SAFETY HAZARD TO YOU OR OTHERS.

THE FOLLOWING WARNINGS ARE FOUND UPON THIS PRODUCT.

⚠ ADVERTENCIA	⚠ ATTENTION		⚠ WARNING
Riesgo de choque eléctrico. No abra. Adentro no hay piezas reparables por el usuario. Mantenimiento solamente por personal calificado.	Risque de secousse électrique. Ne pas ouvrir. Pas de pièces réparables par l'utilisateur. Entretien seulement par personnel qualifié.		Electrical shock hazard. Do not open. No user serviceable parts inside. Refer servicing to qualified service personnel.

THIS SAFETY MESSAGE MEANS THAT YOU COULD BE SERIOUSLY HURT OR KILLED IF YOU OPEN THE PRODUCT AND EXPOSE YOURSELF TO HAZARDOUS VOLTAGE.

⚠ ADVERTENCIA	⚠ ATTENTION		⚠ CAUTION
RODILLOS CALIENTES. PUNTO DE PINCHAMIENTO. Mantener manos y ropa a distancia.	ROULEAUX CHAUDS. POINT DE PINCEMENT. Tenir mains et vêtements à l'écart.		HOT ROLLS. PINCH POINT. Keep hands and clothing away.

THIS SAFETY MESSAGE MEANS THAT YOU COULD BE BURNED AND YOUR FINGERS AND HANDS COULD BE TRAPPED AND CRUSHED IN THE HOT ROLLERS. CLOTHING, JEWELRY AND LONG HAIR COULD BE CAUGHT IN THE ROLLERS AND PULL YOU INTO THEM.

⚠ ADVERTENCIA	⚠ ATTENTION		⚠ CAUTION
NAVAJA FILOSA. Mantener manos y dedos a distancia.	LAME COUPANTE. Tenir mains et doigts à l'écart.		SHARP BLADE. Keep hands and clothing away.

THIS SAFETY MESSAGE MEANS THAT YOU COULD CUT YOURSELF IF YOU ARE NOT CAREFUL.



WARNING: THE SAFETY ALERT SYMBOL PRECEDES EACH SAFETY MESSAGE IN THIS INSTRUCTION MANUAL. THE SYMBOL INDICATES A POTENTIAL PERSONAL SAFETY HAZARD TO YOU OR OTHERS.



WARNING: DO NOT ATTEMPT TO SERVICE OR REPAIR THE FALCON 60+ (-1) LAMINATOR.



WARNING: DO NOT CONNECT THE LAMINATOR TO AN ELECTRICAL SUPPLY OR ATTEMPT TO OPERATE THE LAMINATOR UNTIL YOU HAVE COMPLETELY READ THESE INSTRUCTIONS. MAINTAIN THESE INSTRUCTIONS IN A CONVENIENT LOCATION FOR FUTURE REFERENCE.

⚠ CUIDADO
⚠ ATTENTION
⚠ CAUTION
Hot surface.
Surface chaude.
Superficie caliente.

HOT SURFACE. USE CAUTION AS HOT SURFACE COULD CAUSE BURNS.

Important Safeguards



WARNING: TO GUARD AGAINST INJURY, THE FOLLOWING SAFETY PRECAUTIONS MUST BE OBSERVED IN THE INSTALLATION AND USE OF THE LAMINATOR.

General

Keep hands, long hair, loose clothing, and articles such as necklaces or ties away from the front of the heat and pull rollers to avoid entanglement and entrapment.

The heat rollers can reach temperatures over 300° F (150° C). Avoid contact with the heat rollers during operation or shortly after power has been removed from the laminator.

Keep hands and fingers away from the path of the sharp film cutter blade located at the film exit.

Do not use the laminator for other than its intended purpose.

Avoid moving the laminator on uneven floor surfaces. Never tilt the laminator.

Do not defeat or remove electrical and mechanical safety equipment such as interlocks, shields and guards.

Do not insert objects unsuitable for lamination or expose the equipment to liquids.

Electrical

The laminator should be connected only to a source of power as indicated in these instructions and on the serial plate located on the rear of the laminator. Contact an electrician should the attachment plug provided with the laminator not match the receptacles at your location.



CAUTION: The receptacle must be located near the equipment and easily accessible.

Do not operate the laminator with a damaged power supply cord or attachment plug, upon occurrence of a malfunction, or after the laminator has been damaged. Contact GBC's Technical Service Department or your dealer/distributor for assistance.

Service

Perform only the routine maintenance procedures referred to in these instructions.



WARNING: Do not attempt to service or repair the laminator.

Disconnect the plug from the receptacle and contact GBC's Technical Department or your dealer/distributor when one or more of the following has occurred.

- The power supply cord or attachment plug is damaged.
- Liquid has been spilled into the laminator.
- The laminator is malfunctioning.
- The laminator does not operate as described in these instructions.

Limited 90-Day Warranty

GBC warrants to the original purchaser for a period of ninety days on labor and one year on parts after installation that this laminator is free from defects in workmanship and material under normal use and service. GBC's obligation under this limited warranty is limited to replacement or repair, at GBC's option, of any part found defective by GBC without charge for material or labor.

THIS LIMITED WARRANTY IS IN LIEU OF ALL OTHER WARRANTIES EXPRESSED OR IMPLIED. WARRANTIES OF MERCHANTABILITY OR FITNESS FOR A PARTICULAR PURPOSE ARE EXPRESSLY EXCLUDED. ANY REPRESENTATIONS OR PROMISES INCONSISTENT WITH, OR IN ADDITION TO, THIS LIMITED WARRANTY ARE UNAUTHORIZED AND SHALL NOT BE BINDING UPON GBC. IN NO EVENT SHALL GBC BE LIABLE FOR ANY SPECIAL, INCIDENTAL, OR CONSEQUENTIAL DAMAGES, WHETHER OR NOT FORESEEABLE.

This limited warranty shall be void if the laminator has been misused; mishandled; damaged by negligence, by accident, during shipment, or due to exposure to extreme conditions; repaired, altered, moved, or installed by anyone other than GBC or its authorized agents; or if incompatible film was used. GBC's obligation under this limited warranty does not include routine maintenance, cleaning, adjustment, normal cosmetic or mechanical wear, or freight charges.

Without limiting the generality of the previous paragraph, GBC's obligation under this limited warranty does not include:

1. Damage to the rollers caused by knives, razors, or other sharp tools; by any foreign objects falling into the working area of the laminator; or by cleaning the laminator with solutions or materials that harm its surfaces;
2. Damage caused by adhesives; nor
3. Damage caused by lifting, tilting or attempting to position the laminator other than rolling it on its castors across even surfaces.

FOR EUROPEAN UNION RESIDENTS ONLY: This guarantee does not affect the legal rights which consumers have under applicable national legislation governing the sale of consumer goods.

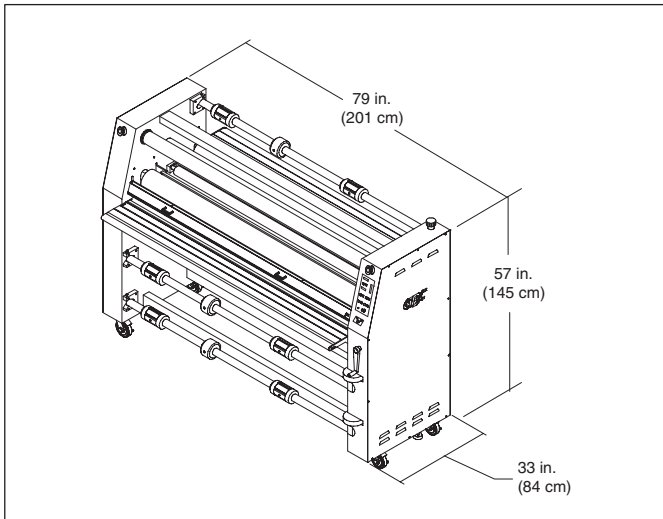

Fig 1

Specifications

Operating Speed:

0 fpm to 18 fpm (5 mpm)

Maximum Film Width:

60 in. (152 cm)

Maximum Mounting Gap:

1 in. (2.54 cm)

Maximum Temperature:

300°F (150° C) Top + Bottom

Dimensions (W x L x H):

Unit alone: (Figure 1)

79 in. x 33 in. x 57 in.

(201 cm x 84 cm x 145 cm)

Shipping:

85 in. x 44.5 in. x 78 in.

(216 cm x 113 cm x 198 cm)

Weight:

Unit alone: 1498 lb. (679 kg.)

Shipping: 1900 lb. (862 kg.)

Noise Rating:

LpA: 66dB A (Sound Pressure Level) Fans OFF

LpA: 67dB A (Sound Pressure Level) Fan ON

Electrical Requirements:

Refer to the serial plate located on the rear of the laminator for the specific electrical rating applicable to the unit.

Voltage: 400V~50 Hz

Current: 13A

Power: 7,500 W

Phase: 3

Interrupting Capacity: 1500A

Ambient Air Temperature: 5-40 °C (41-104 °F)

Humidity Rating: 30-95% non-condensing

Altitude Rating: Up to 1000 Meters Min. (2540 Feet)

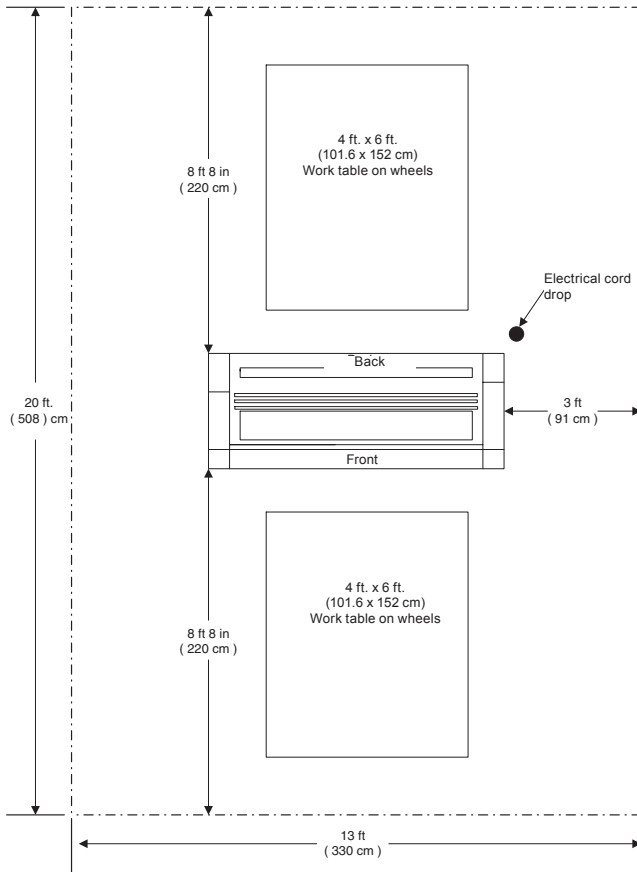

Fig 2

Pre- Installation

Before a Falcon 60+ (-1) Laminator can be installed, ensure the following requirements are met;

1. Are door ways and hallways wide enough for the laminator to be moved to the installation site?
2. Is there ample room for the laminator?
 - A work area must be established that allows for operation in both the front and rear of the laminator and provides space for efficient material flow. (Figure 2)
3. Is the environment appropriate for the laminator?
 - The laminator requires a clean, dust and vapor free environment to operate properly.
 - Avoid locating the laminator near sources of heat or cold. Avoid locating the laminator in the direct path of forced, heated or cooled air.

CAUTION: Air flow can cause uneven heating/ cooling of the rollers and result in poor output quality

4. Have you contacted a certified electrician to wire the receptacle and ensure that adequate power is being supplied, having the appropriate capacity, over current protection and safety lockouts available?
 - 400V 50 Hz, 3 phase 5 wire service required.

Machine is supplied with:

Cord

- manufacturer: SCAME PARRE
 - type: 211.3237
 - rating: 346V-415V, 32A, 3P+N+E
- Plug
- manufacturer: LAPP KABEL
 - type: OLFLEX CLASSIC-110
 - rating: 5 × 4.0 mm²

Installation

1. **Shipping damage should be brought to the immediate attention of the delivering carrier.**
2. With assistance, carefully roll the laminator into position over flat and even surfaces.
3. The laminator should be positioned to allow exiting film to flow freely to the floor (Figure 3) or a work table. Accumulation of laminate immediately behind the laminator as it exits the equipment may cause the film to wrap around the pull rollers, resulting in a “jammed” condition.
4. Avoid locating the laminator near sources of heat or cold. Avoid locating the laminator in the direct path of forced, heated or cooled air.
5. Leveling of the machine is a customer option. If you choose not to level the laminator and encounter output problems, please level the machine and try your application again before calling for technical support. Resting the laminator on the leveling pads prevent the machine from rolling during set up, operation or servicing. (Figure 4)
6. Connect the attachment plug provided with the laminator to a suitably grounded outlet. **AVOID CONNECTING OTHER EQUIPMENT TO THE SAME BRANCH CIRCUIT TO WHICH THE LAMINATOR IS CONNECTED, AS THIS MAY RESULT IN NUISANCE TRIPPING OF CIRCUIT BREAKERS OR BLOWING FUSES.**

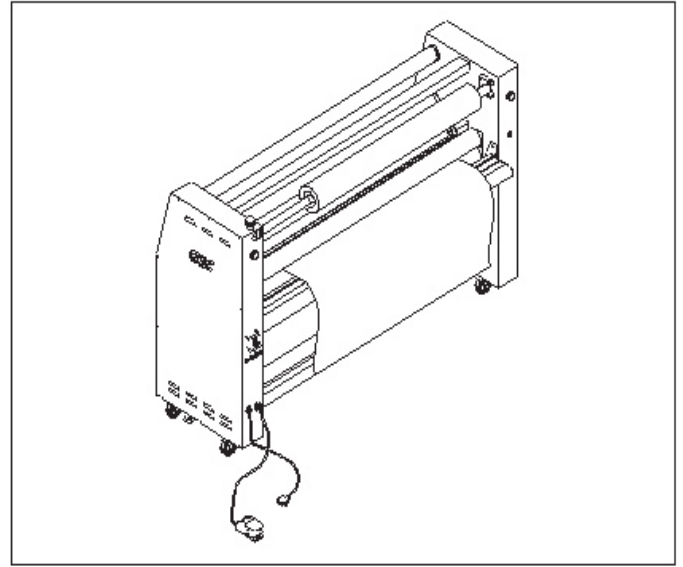

Fig 3

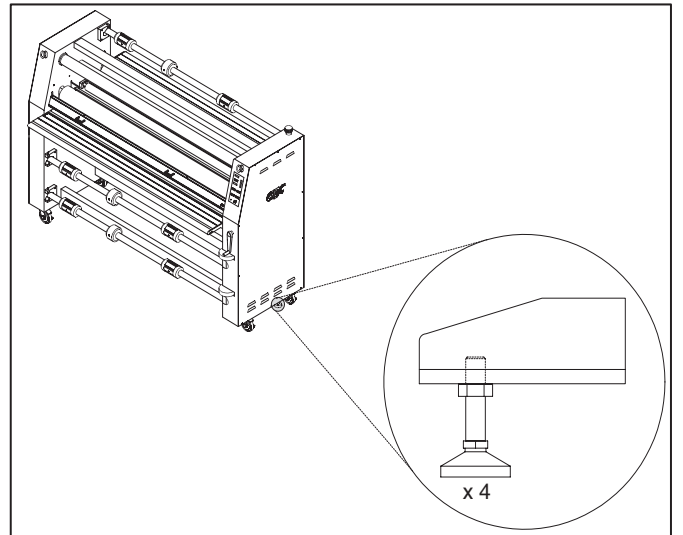

Fig 4

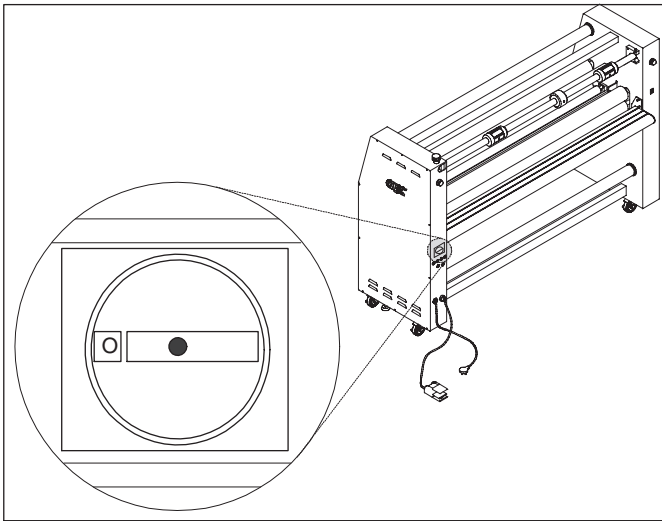

Fig 5

Features Guide

A. POWER ON/ OFF: (Figure 5) Located at the back left of the machine applies power to the laminator. The control panel will illuminate when the switch is rotated to the “I” position. The off position, marked “O”, removes power from the laminator.

B. CONTROL PANEL INDICATORS: (Figure 6)

1. **POWER INDICATOR** : Illuminates when the laminator is plugged in and **POWER ON/ OFF** is in the on, (I), position.
2. **PRESSURE INDICATOR** : Illuminates in increments to correspond with the amount of pressure at the main roller nip. Pressure is represented by percent from 0 (minimal) to 100 (maximum).
3. **READY INDICATOR:** “READY” Illuminates when the actual temperature is equal to (+/- 5) set temperature.
4. **°C INDICATOR:** “°C” Illuminates indicating the displayed value is in degrees Celsius.
5. **°F INDICATOR:** “°F” Illuminates indicating the displayed value is in degrees Fahrenheit.
6. **ON INDICATORS** : Located near the heater and cooling fan on buttons. Illuminates when the related on button is pressed.
7. **SELECTION INDICATORS** : Located near the start/stop and forward/ reverse buttons. Illuminates when the selected button is pressed.

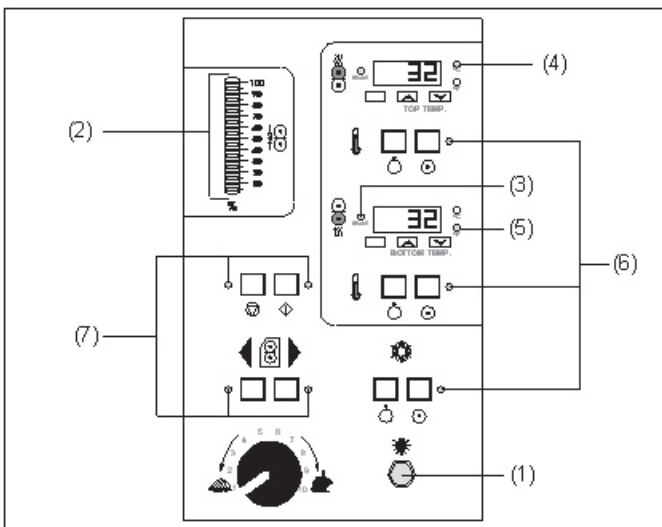

Fig 6

C. CONTROL PANEL BUTTONS: (Figure 7)

1. **START** : When pressed, indicator illuminates and activates rollers for normal operation.
2. **STOP** : When pressed, indicator illuminates and stops the movement of the rollers.
3. **REVERSE** : When pressed, indicator illuminates and sets the motor direction for reverse roller movement to clear film jams and wrap-ups.
4. **FORWARD** : When pressed, indicator illuminates and sets the motor direction for forward roller movement to run in normal operation mode.

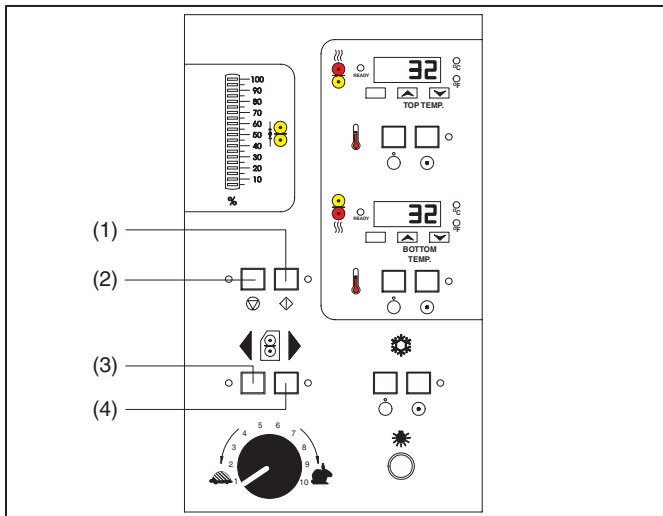











Fig 7

For items 5 -13, refer to Figure 8.

- 5. **SPEED** : This means machine roller speed. Turn clockwise to increase speed or counterclockwise to decrease speed. Speed range is 1 - 10.
- 6. **TEMPERATURE CONTROLS:** The upper and lower heaters have identical controls, on, off, increase, decrease and measure. The top set of controls relate to the upper heater () and the lower set of controls relate to the lower heater ().
- 7. **TEMPERATURE CONTROL ON** : When pressed, indicator illuminates and turns power on to the temperature controller unit.
- 8. **TEMPERATURE CONTROL OFF** : When pressed, turns power off to the temperature controller unit.
- 9. **TEMPERATURE INCREASE** : When pressed, increases the temperature set point value.
- 10. **TEMPERATURE DECREASE** : When pressed, decreases the temperature set point value.
- 11. **TEMPERATURE MEASURE:** When pressed, flashes the actual temperature of the roller.
- 12. **COOLING ON** : When pressed, indicator illuminates and turns on the cooling fans.
- 13. **COOLING OFF** : When pressed, turns off the cooling fans.

D. E-STOP: Four emergency stop buttons exist on the laminator. Two located on the left and right front and two on the left and right rear of the laminator. (Figure 9)
To engage, push (1) any emergency stop push button. Power to the motor is removed. To disengage, turn (2) the push button 1/4 turn counterclockwise.

E. SAFETY SHIELD INTERLOCK LATCH: (Figure 10)
Used to lock the safety shield into position and activate an interlock switch. The interlock latch is located on the left side of the safety shield. When pushed to the full left (1), the safety shield is locked. When pushed to the full right (2), the safety shield is unlocked.

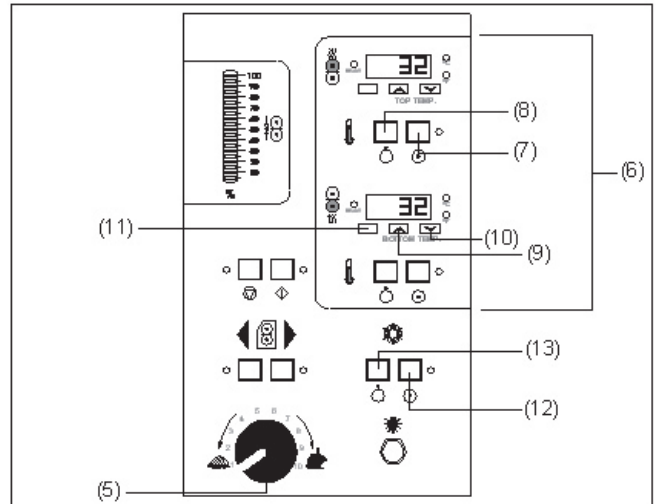

Fig 8

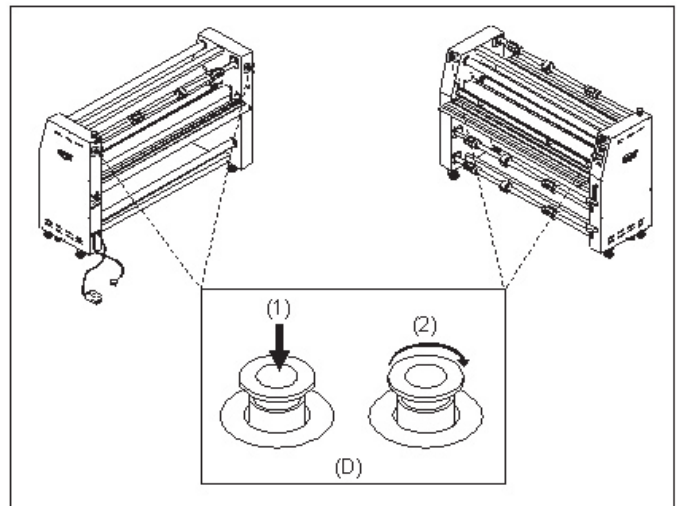

Fig 9

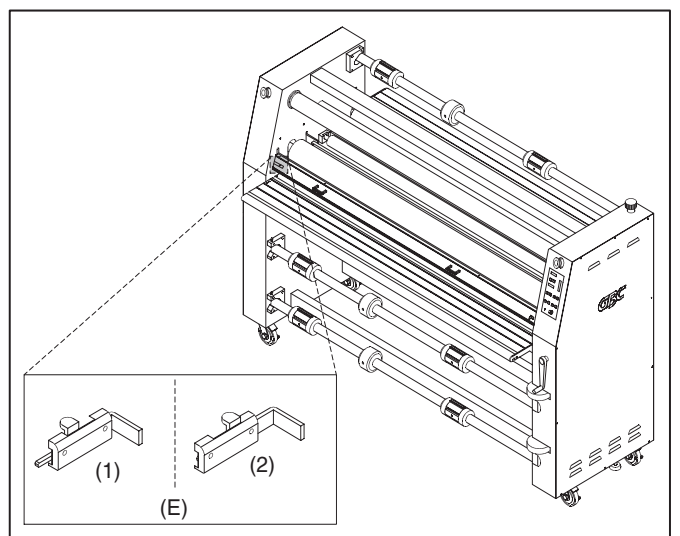

Fig 10

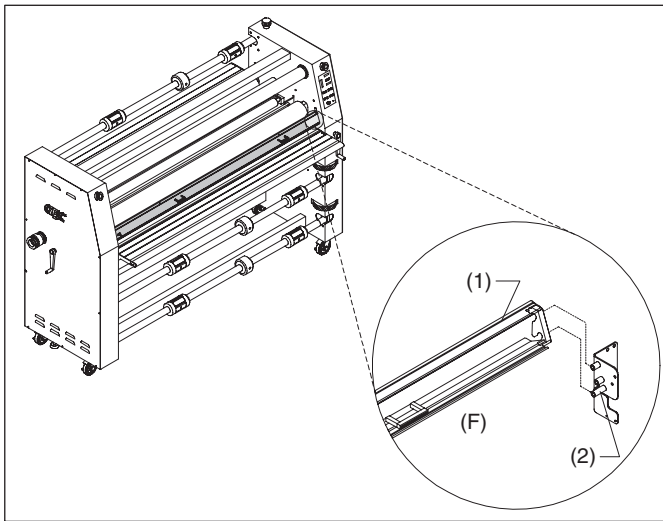

Fig 11

F. SAFETY SHIELD: (Figure 11) Prevents entanglement, entrapment and inadvertent contact with the heat rollers. **The laminator will operate normally only when the Safety Shield is located in the fully locked and closed position. When shield is open, the laminator will only run at 1 mpm (approximately 3.25 ft/m).**

To remove the safety shield, unlock the safety shield interlock latch and lift the safety shield (1) up and away from the safety shield mounting pins (2).

G. FEED TABLE: (Figure 12) The Feed Table is used to position items for lamination. To pivot the feed table, remove the safety shield, lift up on the feed table, pull back, then carefully lower. The laminator will operate only when the Feed Table is properly installed.

NOTE: You can not raise or lower the main roller with the table pivoted.

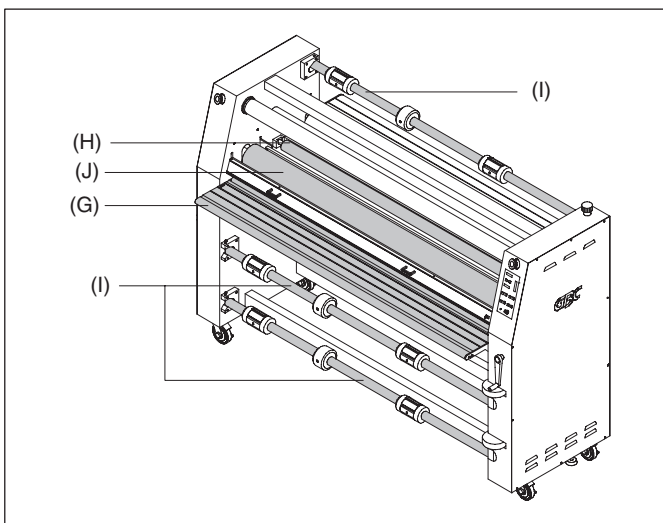

Fig 12

H. CHILL IDLER: (Figure 12) Assist in the cooling process of the web material as it exits the heat rollers.

To remove the chill idler, lift the chill idler straight up and out from the chill idler brackets.

I. FILM SHAFT: (Figure 12) The film shaft holds the film supply on the machine.

J. MAIN ROLLERS: (Figure 12) Silicone rubber coated steel tubes heat the laminating film and compress the heated film to the items being laminated. Heat is provided by an internal heating element. The heat rollers are motor driven for ease of loading new film.

K. IDLER BAR: (Figure 13) The idler bars, located near each heat roller, are used to direct the film to the heat roller nip. The bottom Idler Bar is movable to ease film loading.

L. PULL ROLLERS: (Figure 13) The pull rollers, located at the back of the laminator, are motor driven. They simultaneously pull the film and improve the quality of the laminated item.

M. REWIND TUBE: (Figure 13) The front rewind tube is used to rewind release liner while the rear bottom rewind tube is used to rewind finished product. To remove the rewind tube, push the tube against the rewind brake and remove the tube from the rewind support side.

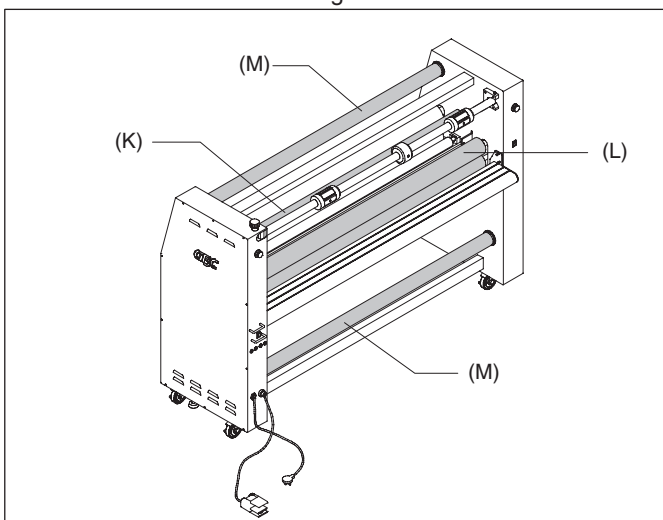

Fig 13

N. FILM SHAFT BRAKE: (Figure 14) Used to apply resistance to the film shaft. One for the upper unwind and one for each of the lower unwinds.

To increase film shaft brake, turn the film shaft brake dial clockwise. Counter clockwise will decrease film shaft brake tension.

O. CORE ADAPTERS: (Figure 14) Hold and lock the rolls of film on the shafts to prevent side to side shifting.

P. CENTER CORE SUPPORT: (Figure 14) Supports the center of the film cores when placed onto the unwind shafts.

Q. REWIND BRAKE: (Figure 15) Located on the right side from the front operating position.

Turn in a forward roller direction to increase rewind brake tension. Reverse roller direction will decrease rewind brake tension.

R. MAIN ROLLER CRANK HANDLE: (Figure 15) Used to raise or lower the upper main roller. Turning the handle clockwise will lower the roller. Counterclockwise will raise the roller.

NOTE: You can not raise or lower the main roller if the feed table is in the tilted position.

S. PULL ROLLER CRANK HANDLE: (Figure 15) Used to raise or lower the upper pull roller. Turning the handle clockwise will raise the roller. Counterclockwise will lower the roller.

T. COOLING FANS: Assist in the cooling process by pushing unheated air onto the web material as it exits the heated rollers. This feature can be controlled from the control panel (Not Shown).

U. CLUTCH: (Figure 16) Used to increase or decrease pull roller clutch tension. Clockwise rotation will increase clutch tension while counterclockwise rotation decreases clutch tension.

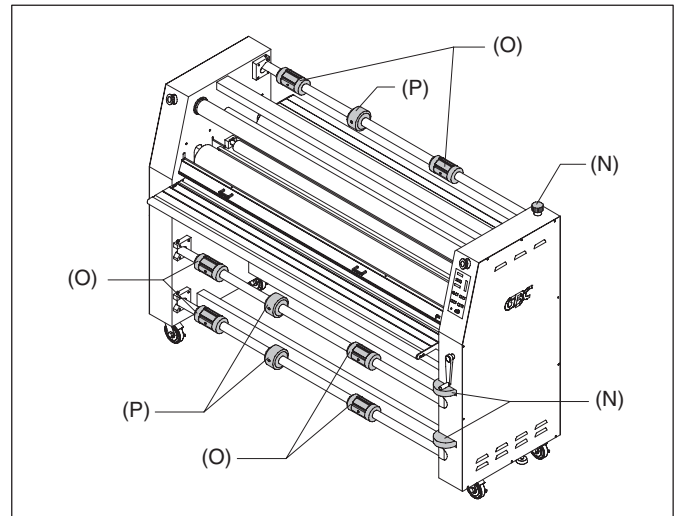

Fig 14

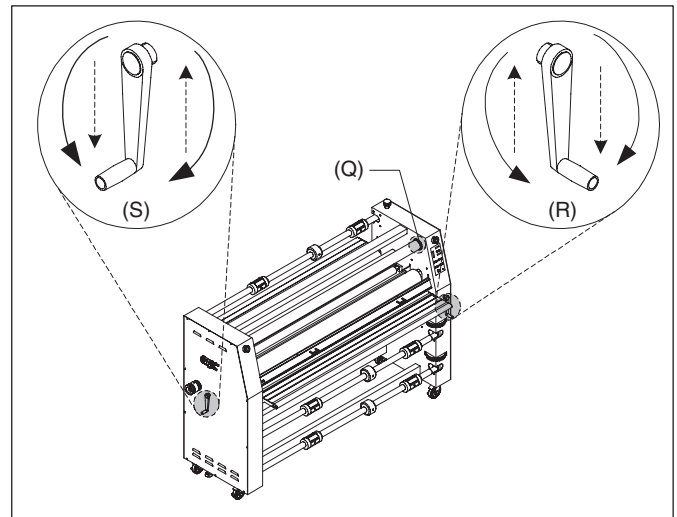

Fig 15

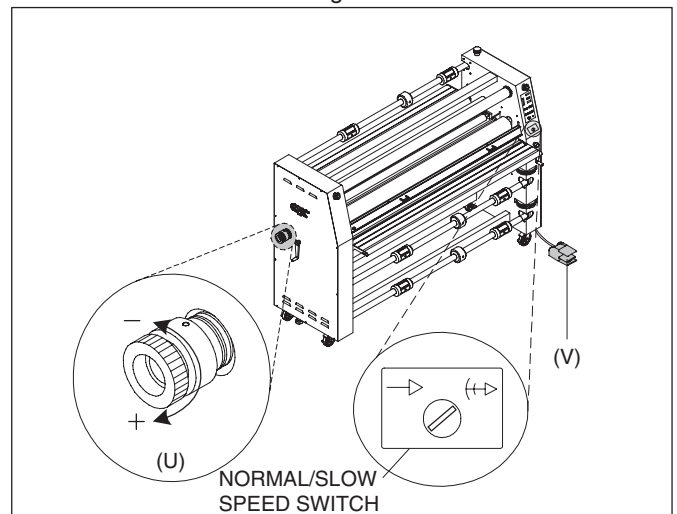

Fig 16

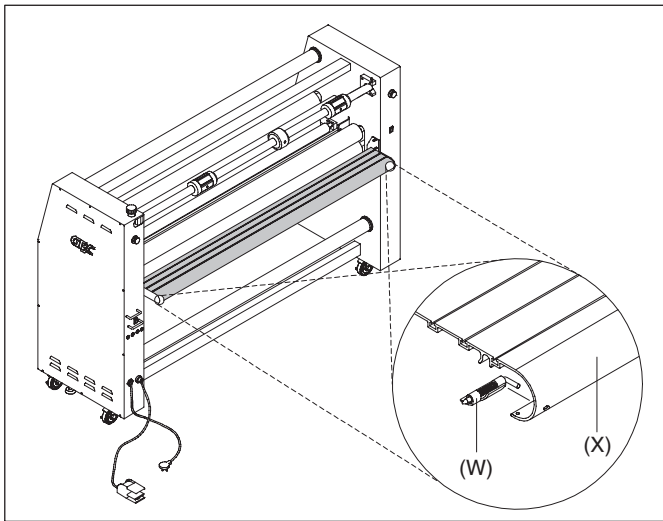

Fig 17

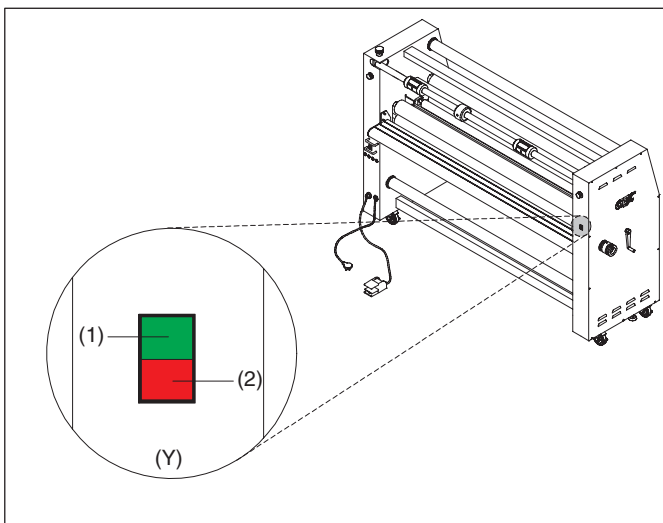

Fig 18

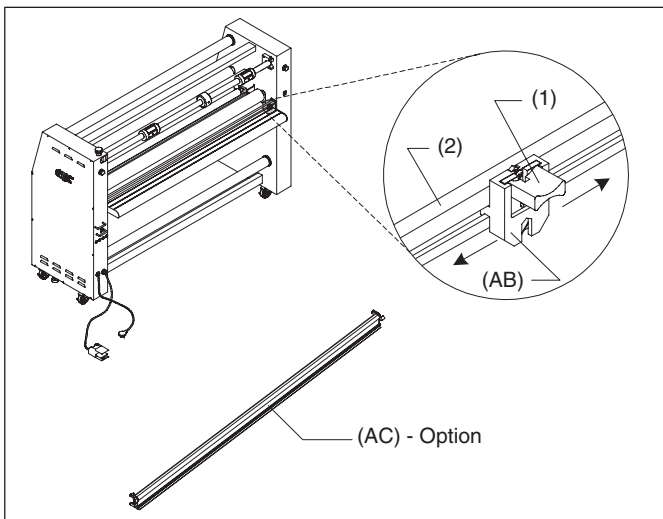

Fig 19

V. FOOTSWITCH: To operate using the footswitch, there are a number of factors that determine how the machine runs based on the position of the key on the Hand – Foot-switch Control and if the safety shields are in place or not. Refer to the chart below for settings and speeds.

Selector key position	Safety shield on (Latch locked)	Safety shield off (Latch Unlocked)
Clockwise ↻	Foot –Pedal: Limited speed of 3f/m or 1m/m	Foot –Pedal: Limited speed of 3f/m or 1m/m.
	Control panel run switch: Limited speed of 3f/m or 1m/m.	Control panel run switch: Limited speed of 3f/m or 1m/m.
Counter Clockwise ↺	Foot –Pedal: Up to Max speed.	Foot –Pedal: No function.
	Control panel run switch: Up to Max. speed.	Control panel run switch: No function.
Selector key removed (Key removed when turned counterclockwise)	Foot –Pedal: Up to Max speed.	Foot –Pedal: No function.
	Control panel run switch: Up to Max. speed.	Control panel run switch: No function.

W.REAR TABLE LATCHES: (Figure 17) Located under the left and right sides of the rear table.

X. REAR TABLE: (Figure 17) Provides a working surface when operating the machine from the rear. This table may also be lowered when webbing for roll to roll applications. To lower, pull the left and right side rear table latches in and lower the rear table.

Y. REAR RUN/ STOP SWITCH: (Figure 18) Located on the right side of the laminator from the rear operating position. This switch permits run (1) / stop (2) control of the motor from the rear operating position.

Z. FILM WEB: Laminating film loaded into the machine (Not Shown).

AA. NIP POINT: The point at which the top and bottom rollers come into contact. The Nip Point of the heat rollers is the place at which the items for lamination are introduced into the laminator (Not Shown).

AB. REAR SLITTER: (Figure 19) Used to cut off the laminated web. To use, push down on the blade engage lever (1) and slide across the rear slitler rail (2) to the opposite side.

AC. SEPARATOR BAR: (Option) (Figure 19) Required if running Accushield™ material. To install, remove the rear slitler and position the separator bar in it's place. **(Falcon 60+ (-1) Part # 2020577)**

Operating Instructions

Film Loading & Threading

The top and bottom rolls of laminating film must be of the same width and be present simultaneously. A small amount of adhesive will “squeeze out” during lamination. Hardened adhesive deposits can damage the heat rollers. To avoid any damage, select “Low-Prs LAMI.” for job mode (), rotate the rollers at slowest speed with heat on. Refer to the section entitled **CARING FOR THE FALCON 60+ (-1) LAMINATOR** for instructions regarding removal of the accumulated adhesive.

Adhesive will deposit on the rollers if:

- The rolls are misaligned.
- Only one roll is used.
- Different widths of rolls are loaded together.
- Either roll is loaded adhesive side against a heat roller.
- One or both rolls of film are allowed to run completely off its core.

The adhesive side of the film is on the inner side of the web (Figure 20). The shiny side of clear film must contact the heat rollers. The dull side of the film contains the adhesive. Use extreme caution when loading delustered (matte) film as both sides appear dull.

Always change the top and bottom supply rolls at the same time. Near the end of each roll of GBC laminating film is a label stating “Warning-End of Roll”. The appearance of this label on either the top or bottom roll requires that new rolls of film be installed as soon as the item presently being laminated completely exits the rear of the laminator. Do not introduce any additional items into the laminator when the warning label is visible.

To load a roll of film; (Figure 21)

1. Pull the clevis pin up.
2. Swing shaft outward.
3. Slide the roll of film onto the film shaft ensuring adhesive side is out.
4. Push the film shaft back into the film shaft support saddle.
5. Push the clevis pin down.
6. Center the roll of film.

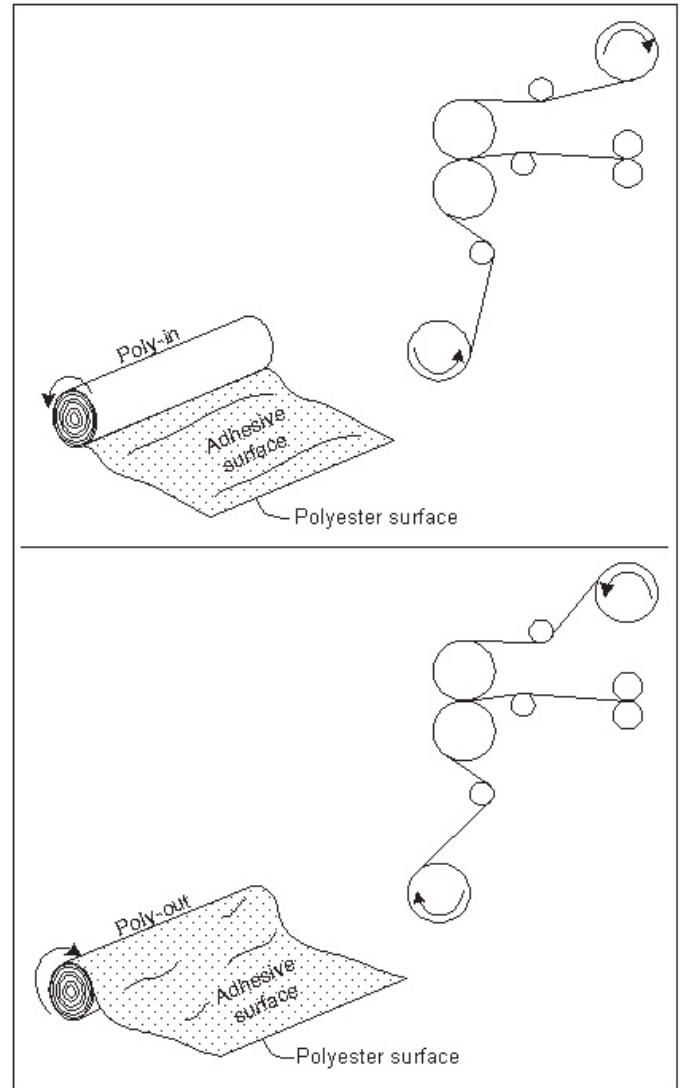

Fig 20

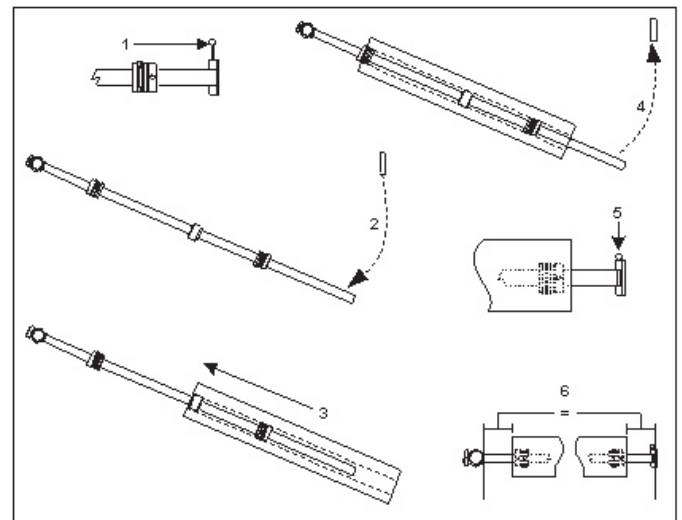

Fig 21

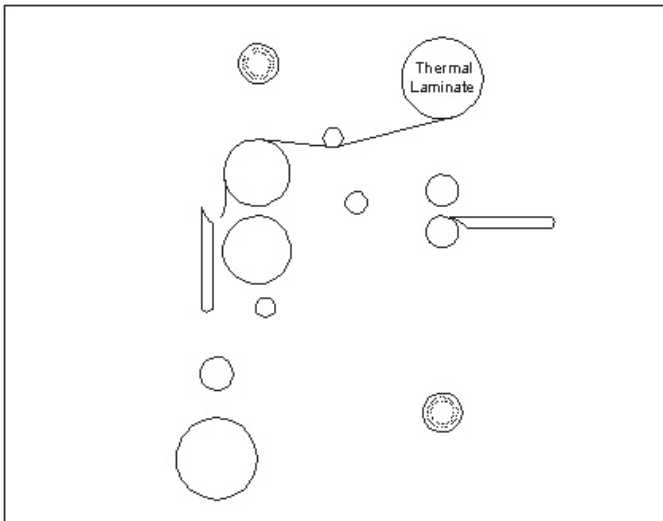

Fig 22

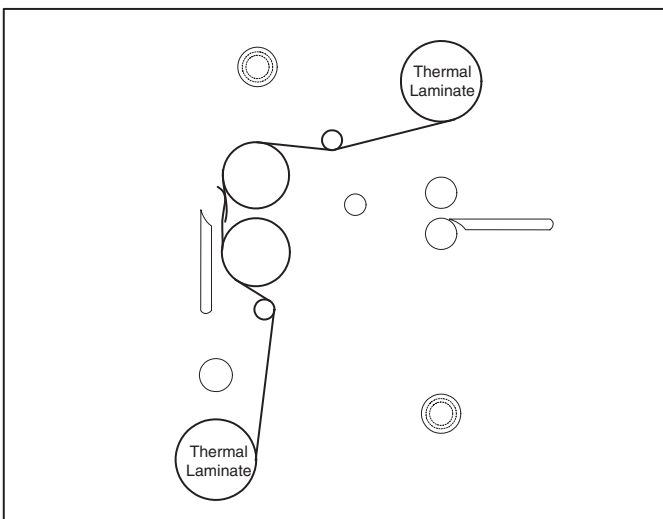

Fig 23

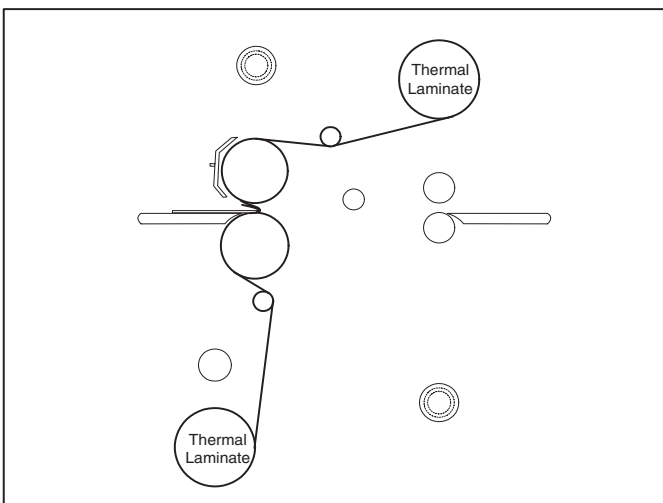

Fig 24

Webbing Thermal Film Using Threading Card

The following procedure uses the film threading card provided with new rolls of GBC film. The laminator rollers will be hot for this procedure. For pressure sensitive film (PSA), refer to the section entitled **WEBBING USING FILM THREADING CARD FOR PSA FILM**.

1. Turn the Power **ON/OFF** to on (I).
2. Set top and bottom temperature with regards to the film type used.
3. Ensure no brake tension is applied to the film shafts.
4. Remove the safety shield and pivot the feed table down.
5. Pull the top roll of film down under the upper idler bar and allow to drape over the top heat roller (Figure 22).
6. Pull the lower film behind the lower idler bar and up towards the film draped over the top heat roller (Figure 23).
7. Use a threading card to push the two materials into the heat roller nip.
8. Pivot the table back to its feeding position while ensuring the threading card is on top of the feed table (Figure 24).
9. Use the main roller pressure handle to bring the main roller to initial contact with the threading card.
10. Replace the safety shield.
11. Set speed to 3 or less.
12. Ensure forward (▶) is selected for motor direction and press the start (◊) button.
13. From the rear of the machine, guide the web over the chill idler, if installed, and through the pull rollers.
14. Once the web has entered the pull roller nip, use the pull roller pressure handle to close the pull roller nip.
15. Once the threading card has completely exited the pull rollers, press the stop (▽) button.
16. **Open the main roller nip.**
17. Now refer to the section entitled **START LAMINATING**.

Webbing PSA Film/Mount Adhesive Using Threading Card

The laminator should be cool to the touch before proceeding.

1. Turn the Power **ON/OFF** to on (I).
2. Load the rolls of film as illustrated in Figure 25. Ensure no brake tension is applied to the film shafts.
3. Remove the safety shield and pivot the feed table down.
4. Pull the top roll of film down under the idler bar and up to the upper front rewind tube.
5. Place one piece of masking tape in the center of the film and secure to the rewind tube.
6. Make two full wraps around the rewind tube, then carefully score the laminate without cutting the release liner. Pull the laminate down allowing it to drape over the upper heat roller (Figure 25).
7. Pull the mount adhesive up towards the film draped over the upper heat roller (Figure 26).
8. Use a threading card to push the two materials through the heat roller nip.
9. Pivot the table back to it's feeding position while ensuring the threading card is on top of the feed table (Figure 27).
10. Replace the safety shield.
11. Use the main roller pressure handle to bring the main roller to initial contact with the threading card. Set speed to 3 or less.
12. Set speed to 3 or less. Ensure forward (▶) is selected and press the start (◀▶) button.
13. From the rear of the machine, guide the web over the chill idler, if installed, and through the pull rollers.
14. Once the web has entered the pull roller nip, use the pull roller pressure handle to close the pull roller nip.
15. Press the stop (◻) button Once the threading card has completely exited the pull rollers,.
16. Open the main roller nip.
17. Now refer to the section entitled **START LAMINATING**.

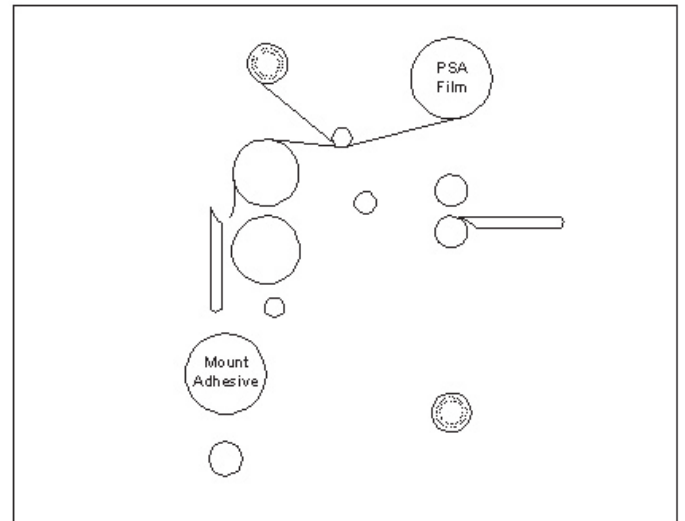

Fig 25

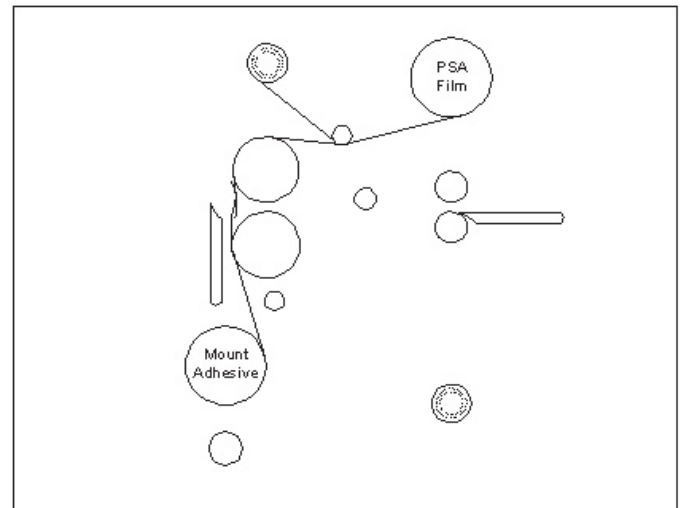

Fig 26

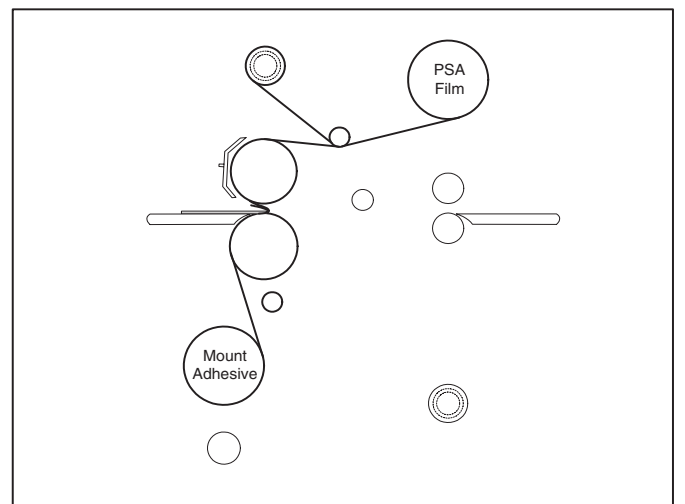

Fig 27

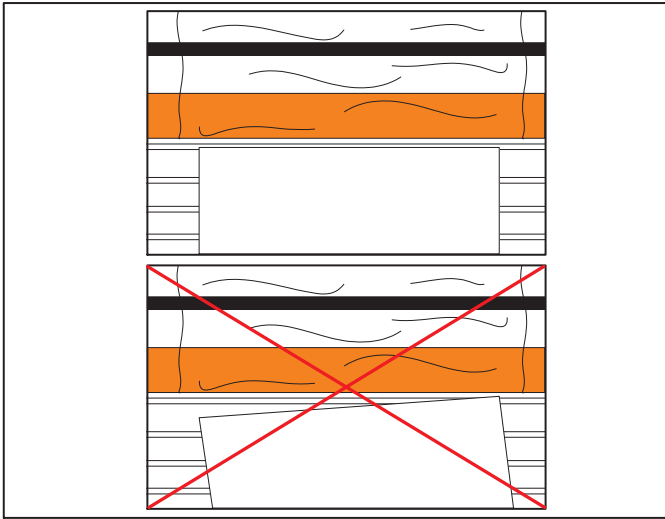

Fig 28

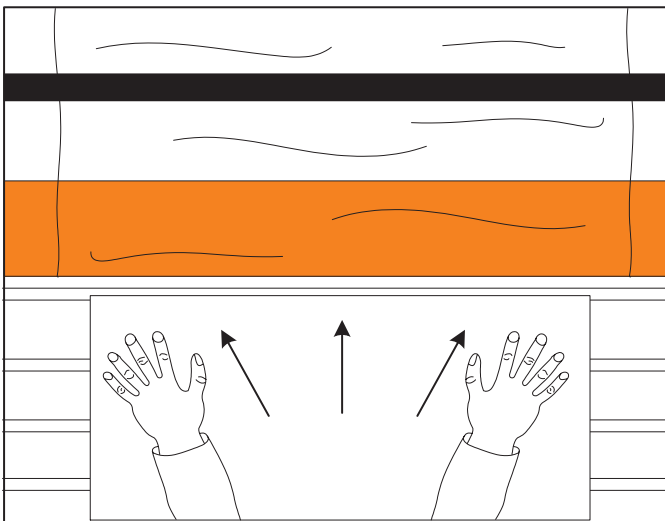

Fig 29

Start Laminating

1. At this point you should have your laminator webbed with the appropriate material for your application.
2. The safety shield and feed table should be in the normal operating position.
3. The main rollers should be open and the pull rollers should be closed.
4. Speed is set to 3 or less and forward () motor direction is selected.
5. Press the start () button.
6. Set main roller pressure between 40 - 50% for laminating.

CAUTION: If using PSA film, an air pocket may result between the main rollers and pull rollers. Raise the pull rollers to allow the air pocket to pass.

7. Make any necessary film brake tension, pull/ main roller pressure, clutch and/ or rewind brake tension adjustments.
8. Position the item to be laminated on the feed table.
9. Align the leading edge of the item square to the heat roller nip (Figure 28).
10. With both hands and an outward force push the image slower than the speed of the rollers into the nip of the heat rollers (Figure 29).

CAUTION: Avoid forcing the image into the main roller nip as this action will cause the corners of the leading edge to buckle and create a wave.

Method For Tacking New Film To Existing Film

The following describes a method for loading film whereby the existing film present on the heat rollers may be used in place of the threading card to draw the new film through the laminator. The adhesive of the existing film must be tacky or liquefied. Leading edges of the new film will be overlapped onto the tacky adhesive of the old film. The existing film and the new film will be pulled through the laminator together.

1. Cut (1) remaining top film web between the idler bar and heat roller. Cut (2) the film web between the lower film supply and the idler bar (Figure 30).

CAUTION: Be careful not to cut any of the rollers!

2. Remove the safety shield and tilt the feed table down.
3. Do not allow the adhesive side of the film to contact the heat or pull rollers. Liquefied or tacky adhesive deposited on heat rollers will require the rollers to be cleaned per the section entitled **CARING FOR THE FALCON 60+(-1) LAMINATOR.**
4. Replace both the top and bottom rolls of film with new rolls. Ensure the adhesive side is facing out.
5. Pull the film around the idler bars, with the exception of PSA mounting adhesives without a release liner.
6. Tack the new film to the existing film on the heat rollers. For PSA film, attach the release liner to the rewind tube (Figure 31).
7. Use the footswitch to advance the film into the heat roller nip.
8. Observe the film being pulled through the laminator to assure that the remaining existing film and the new film are advancing concurrently. Any separation between the films will require stopping the motor immediately and the situation corrected.
9. Press **STOP** (⏹) once the newly threaded film has completely exited the pull rollers.

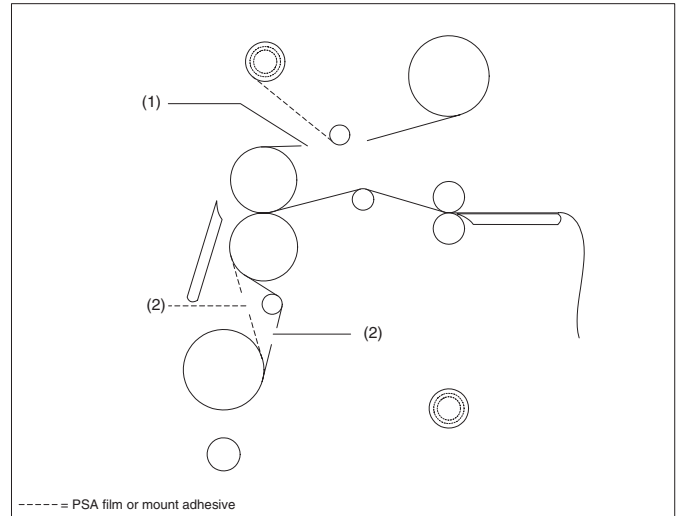

Fig 30

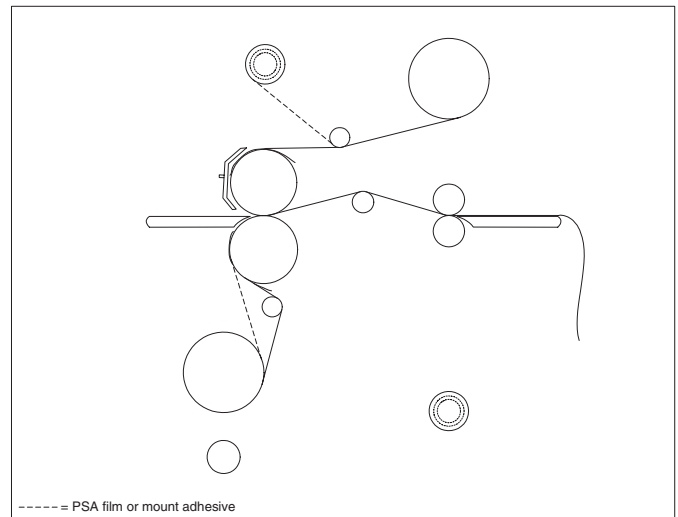

Fig 31

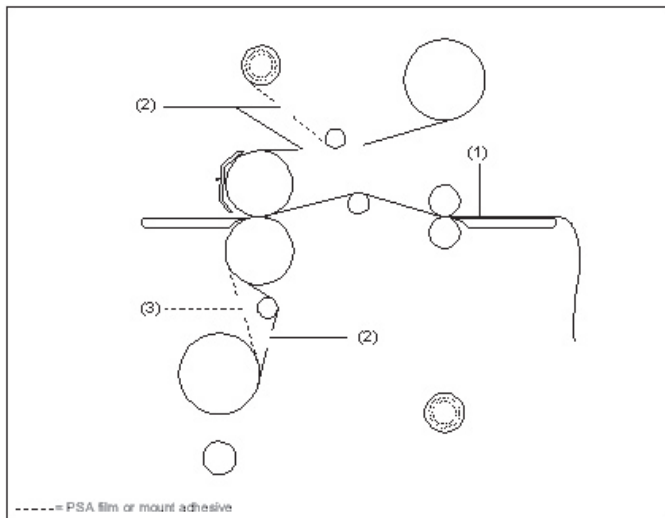

Fig 32

To Unweb the laminator

Unweb the laminator if you are changing film widths, cleaning the rollers or have finished using the machine for the day.

1. Using the rear slit, cut (1) the output from the web (Figure 32).
2. Cut (2) remaining top film web between the idler bar and heat roller. PSA film, cut the release liner too.
3. Cut (3) the film web between the lower film supply and the idler bar (Figure 32).

CAUTION: Be careful not to cut any of the rollers!

4. Remove the safety shield and tilt the feed table.
5. Gap the main rollers and pull rollers.
6. Carefully grab hold of the web (top and bottom film), from the front operating position and pull towards you (Figure 33).
7. Do not allow the adhesive side of the film to contact the heat or pull rollers.

Clearing a Film Jam (Wrap-up)

Film jams (wrap-ups) may occur if the film is loaded backwards or if the area at which film exits the equipment is blocked. The film, when jammed, wraps around the heat rollers during webbing if a threading card is not used or pull rollers are not used during operation.

To clear a jam:

1. Immediately stop the laminator by pressing **STOP** (⏏).
2. Remove the safety shield and tilt the feed table.
3. Set motor direction to reverse and key switch to foot.
4. Use the footswitch to reverse the web until the wrap up is clear.
5. Raise the main roller and pull rollers.
6. Manually guide the web from the main rollers and pull rollers.
7. Once the film jam has been cleared, lower the main roller and pull rollers.
8. Refer to the section titled **START LAMINATING**.

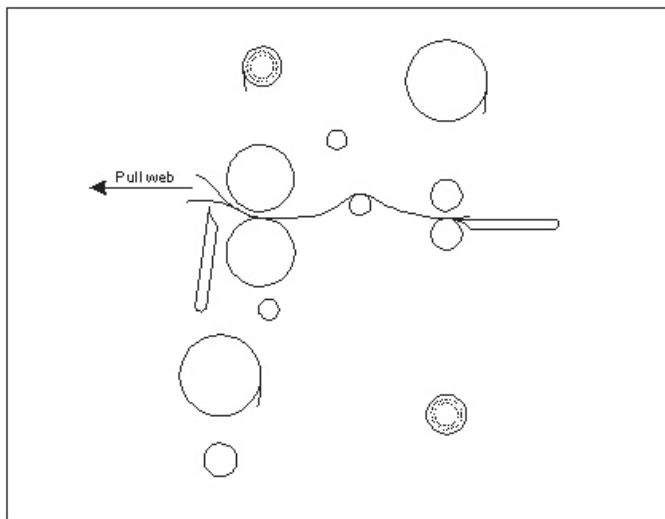

Fig 33

Applications

Tips For Pre Coating Boards (Figure 34)

1. Load the laminator as illustrated in Figure 34. Remove chill idler.
2. The width of the roll should not exceed the width of the board by more than 1/2 in. (1.3 cm).
3. Use a leader board to set the main roller and pull roller pressure prior to webbing.
4. Use a leader board to start the run and a trailer board to finish the run.
5. Using the pull rollers will allow you to leave gaps between boards.
6. If not using the pull rollers, have the boards nearby to butt end to end during feeding.

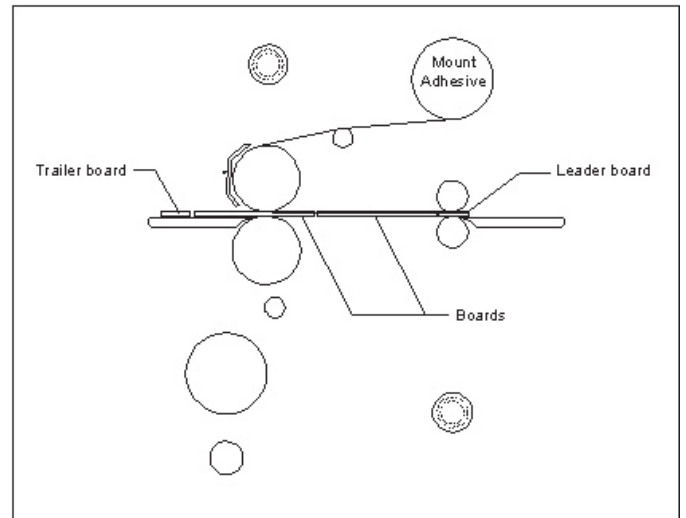

Fig 34

Tips For Mounting Pre Coated Boards (Figure 35)

1. This application can also be performed from the rear operating position.
2. Use a leader board to set the main roller pressure prior to mounting the image.
3. Ensure the chill idler is removed and the rear slitter is to one side.
4. Heat, 125°F (52°C), may assist the process and increase output quality.
5. Do not stop once you have started the mounting process through the machine.

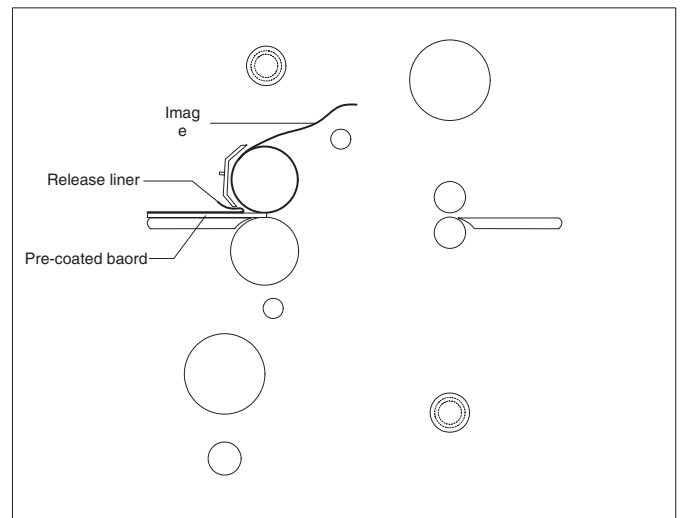

Fig 35

Tips For Single Sided lamination (Figure 36)

1. Load the laminator as illustrated in Figure 36.
2. Use kraft paper for one-sided lamination whenever the items to be laminated are narrower than the film you are using.
3. If not using kraft paper, use a scrap piece to finish the run or you will have adhesive on your rollers.
4. For high volume runs, use Kraft paper and the lower rear rewind for roll to roll operation.
5. Running the web over the chill idler may improve the flatness of the output.
6. A little heat, 125°F (52°C), may help eliminate silvering effects associated with PSA films.

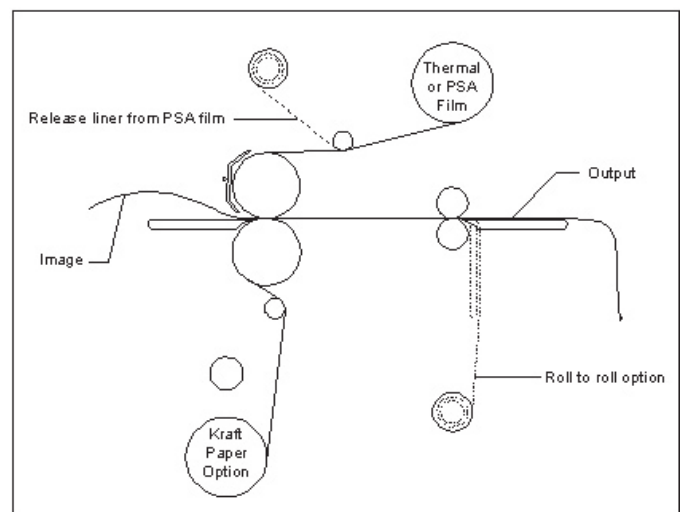

Fig 36

**Tips for ACCUSHIELD
(Figure 40)**

1. Load the laminator as illustrated in Figure 40.
2. You must have the Separator bar option to accurately run this material.
3. Set Top Temp. to 265°F (129°C) and a speed setting no greater than 4.
4. Liner rewind tension will be greater than normal operating standards.
5. To prevent some adhesive adhering to the rollers, you may choose to use a roll of kraft paper for a carrier.

Use the blank space below and blank diagrams to note your tips and web paths for your special applications.

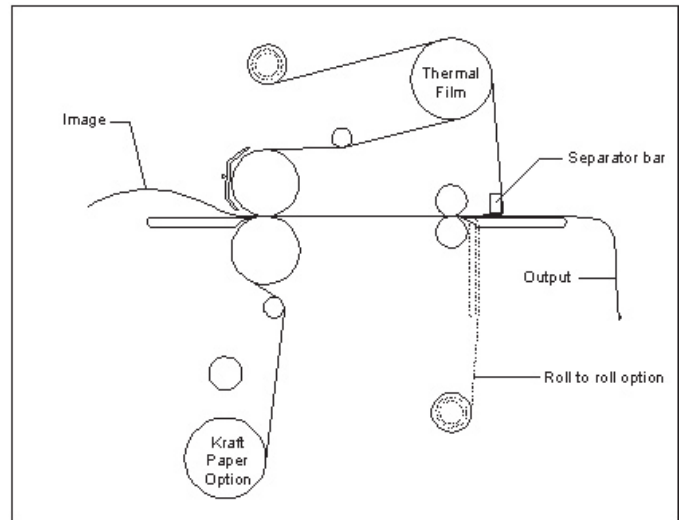

Fig 40

TIPS FOR CUSTOM APPLICATION #1 (Figure 41)

1.

2.

3.

4.

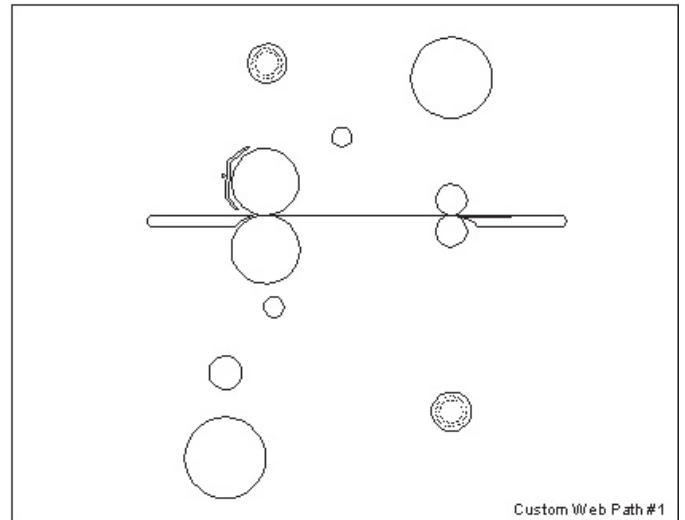

Fig 41

TIPS FOR CUSTOM APPLICATION #2 (Figure 42)

1.

2.

3.

4.

5.

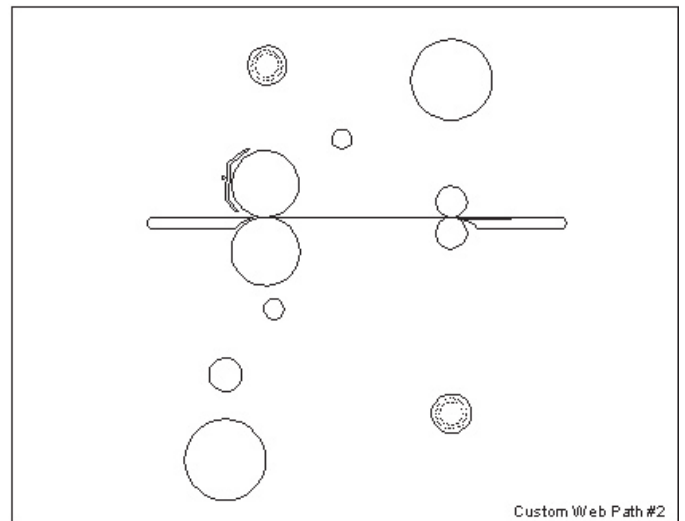

The Art of lamination

Basic Rules

Do not attempt to laminate abrasive or metal objects such as staples, paper clips and glitter, as they may damage the heat or pull rollers.

Do not force items into the nip area of the heat rollers. An item that is not easily drawn into the laminator by the heat rollers is probably too thick to laminate.

Wrinkles may result if an attempt is made to reposition an item once it has been grasped by the heat rollers.

Do not stop the laminator before an item has completely exited the pull rollers. Even a momentary stop will cause a mark (heat line) on the laminated item.

Good, consistent lamination is a result of combining proper heat, tension and dwell time. Dwell time is controlled by the speed of the motor and is defined as the amount of time the material to be laminated is compressed between the heat rollers.

As a general rule, thicker items and film need to run at slower speeds because they extract more heat from the rollers at a quicker rate. Setting the speed control at slower settings gives the laminator longer dwell time thus allowing proper lamination of thick items. Thinner items, such as standard copier paper (20 lb. bond) and tissue paper, extract less heat from the rollers and can be run at faster speeds.

FILM TENSION

Proper film tension, known as brake tension, is the minimum amount required to eliminate wrinkles in the finished item. The film should be taut. A properly adjusted roll of film should not require excessive force to turn by hand.

Film tension should be enough to introduce a minor amount of drag as the film unrolls. Insufficient tension causes wrinkles, while too much tension causes stretching (necking). Uneven tension between the top and bottom rolls create curl. Too much upper tension creates upward curl while too much bottom tension causes downward curl.

Adjustment of the pull roller clutch may be necessary if after adjusting unwind and rewind brake tensions do not improve your output quality.

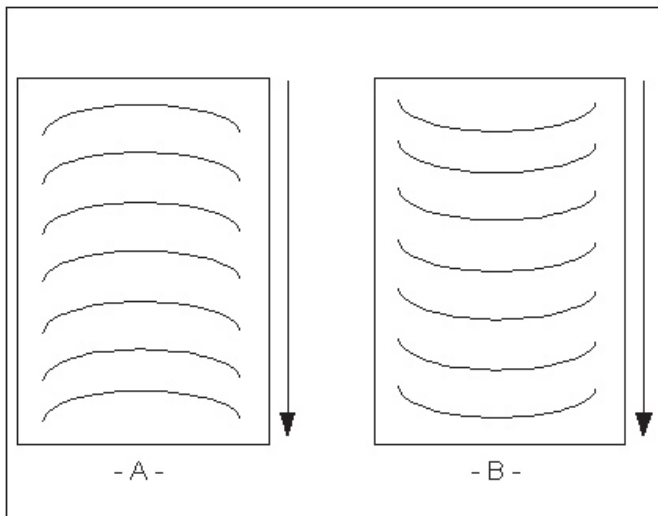

Fig 45

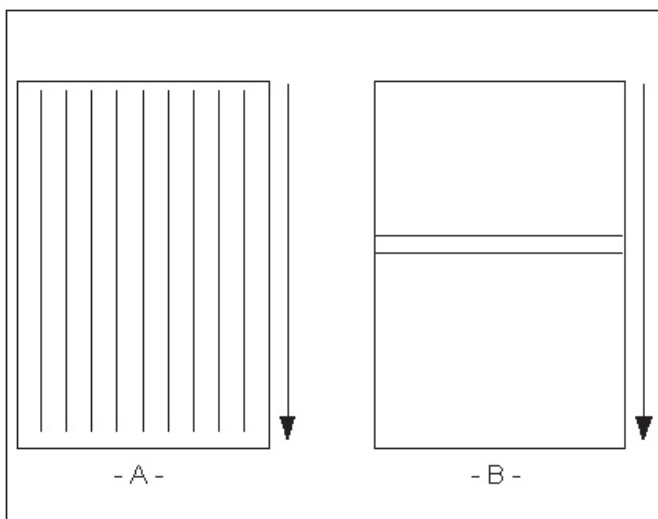
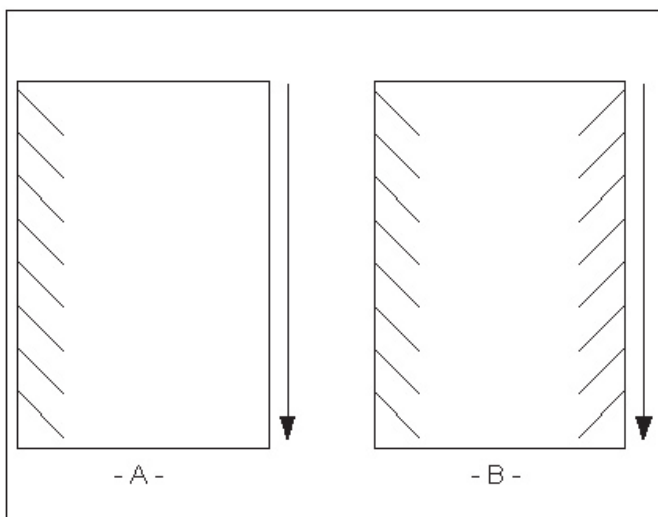

Fig 46



Heat

The "READY" indicator may extinguish if the speed is set too fast for the material being laminated. Either lower the speed setting or press STOP (⏹) and wait until the "READY" indicator illuminates.

Operation of the laminator for more than thirty minutes at a time may necessitate a lower speed setting. It is recommended that, during periods of long runs, the items being laminated are alternated between thick and thin. Do not combine thick and thin items at the same time, as this will result in a poor edge seal around the thinner material. If you are unsure that the laminator is set at the proper speed for the item to be laminated, run a test piece (scrap) of the same or similar material through the laminator. This procedure is recommended because rotating the heat roller prior to lamination will more evenly distribute the heat. Make speed adjustments if necessary.

Output

1. "D" waves in the image (Figure 45 A).

- Check paper tension.
- Paper may be damp or not dry.

2. "D" waves in the laminate (Figure 45 B).

- Check main roller pressure.
- Check pull roller pressure.

3. Straight waves in output (Figure 46 A).

- Check operational settings for materials being used.
- Check clutch tension.

4. Indent waves in output after pull rollers (Figure 46B).

- Insufficient cooling time.
- Output was handled prior to cooling.
- Use cooling feature if not on.
- Machine was stopped on print.

5. Angled waves in the output (Figure 47 A & B).

- Check main roller pressure.
- Check pull roller pressure.
- Check for even paper tension. (Figure 49 A only)

Maintenance

Caring For The GBC Falcon 60+ (-1) Laminator

GBC offers Cleaning kits as well as Extended Maintenance Agreements.

Contact your local GBC Service Representative or your dealer/distributor for additional information.

The only maintenance required by the operator is to periodically clean the heat rollers and schedule semi annual maintenance checks.

The following procedure will help keep the heat rollers free of adhesive that has been deposited along the edge of the laminating film. Proper alignment of the rolls of film reduces the amount of "squeeze out".



WARNING: Do not attempt to laminate adhesives marked "Flammable".

- Do not laminate glitter and/ or metallic items. Damage to the rollers may result.



WARNING: Do not apply any cleaning fluids or solvents to the rollers. Some solvents and fluids could ignite on heated rollers.

- Never clean rollers with sharp or pointed objects.
- Hardened adhesive deposits on the rollers can cause damage to the rollers. Rotate the rollers at the lowest speed setting on the control panel.



CAUTION: THE FOLLOWING PROCEDURE IS PERFORMED WHILE THE LAMINATOR IS HOT. USE EXTREME CAUTION.

1. Remove the film from the laminator following the procedure outlined in steps 1 through 6 of the section entitled **TO UNWEB THE LAMINATOR**.
2. Preheat the laminator until the "READY" indicator illuminates.
3. Remove the safety shield and tilt the feed table.
4. Rub the top and bottom heat rollers with a 3M™ Scotch-Brite™ pad. **DO NOT USE METAL SCOURING PADS!**
5. Use the footswitch to rotate the lower heat/ pull roller to an unclean portion. The upper heat/ pull roller are free spinning. Continue this process until the complete surface of both rollers are clean.
6. Refer to the beginning of the section entitled **OPERATING INSTRUCTIONS** to web your laminator.

***NOTE:** Do not use metal scouring pads to clean the rollers.

Troubleshooting Guide

SYMPTOM	POSSIBLE CAUSE	CORRECTIVE ACTION
<ul style="list-style-type: none"> The control panel display does not illuminate when POWER ON/OFF is in the ON, marked "I", position. 	Laminator not connected to electrical supply.	Insert attachment plug into receptacle.
<ul style="list-style-type: none"> Heat rollers do not turn when I press the START (◊) button. 	Safety shield is not properly installed.	Remove safety shield and properly replace it.
	Feed table not properly installed	Tilt feed table and properly replace it.
	E-STOP is engaged	Pull out on the E-STOP push button.
<ul style="list-style-type: none"> Heat rollers only turn if I use the "footswitch. 	Laminator is in footswitch mode.	Disengage the footswitch mode.
<ul style="list-style-type: none"> Rear controls do not operate. 	Safety shield is not installed in rear position.	Remove the rear slit and install the safety shield.
<ul style="list-style-type: none"> Laminated items exhibit curling. 	Tension between the top and bottom film roll is unequal.	Adjust tension per section FILM TENSION .
	Tension on top or bottom roll of film is too loose.	Adjust tension per section FILM TENSION .
	Bottom film roll may be improperly loaded.	Make sure bottom roll of film is around idler bar and the it is in the normal operating position.
<ul style="list-style-type: none"> Adhesive deposited on heat rollers. 	Top and bottom film webs not aligned.	Release heat and pull roller pressure, align the rolls of film.
	Laminate improperly loaded.	Adhesive (matte) side of laminate film may be against the heat rollers. Unweb and reload the film properly.
<ul style="list-style-type: none"> Unsatisfactory adhesion of laminate. 	Speed setting too fast for type of material being laminated.	Lower speed setting by pressing SLOW button to slower speed
	Insufficient heat.	Wait for " READY " indicator to appear in the control panel display.
	Laminate improperly loaded.	Adhesive side of film must be facing away from the heat rollers.
	Heat rollers require cleaning.	Bottom roll of film not threaded behind the idle bar. Clean heat rollers per procedure in section CARING FOR THE GBC FALCON 60+(-1) LAMINATOR .
	Laminated item unsuitable for adhesion.	Item may be dirty or may have nonporous surface that is extremely difficult to laminate.
<ul style="list-style-type: none"> Waves in my output 	See sub section OUTPUT.	Under section titled THE ART OF LAMINATION.
	Nips may be out of calibration.	Place a service call for calibration check.

SERVICE AGREEMENT

GBC's Equipment Maintenance Agreement will insure the quality performance and long life built into your laminator.

A service charge for travel time, labor and parts may be incurred for each out of warranty service call. GBC's Equipment Maintenance Agreement decreases these expenses and protects your valuable investment. GBC offers several types of agreements to suit your needs and budget. To contact GBC write to:

GBC NATIONAL SERVICE
ONE GBC PLAZA
NORTHBROOK, IL 60062 U.S.A.
1.847.272.3700

EUROPE: GBC FILM GROUP EUROPE
MERCURIUSSTRAAT 9
6468 ES KERKRADE
THE NETHERLANDS

PHONE: +31 (0) 45 535 7651
FAX: +31 (0) 45 535 7878
E-MAIL: info@gbcfilms.com
INTERNETS: www.gbcfilm.com



General Binding Corporation
One GBC Plaza
Northbrook, IL 60062-4195