

---

# FALCON 60 H

# OPERATION & MAINTENANCE

# MANUAL

© APRIL 2001 GENERAL BINDING CORPORATION. ALL RIGHTS RESERVED.

Do not duplicate without written permission.

---

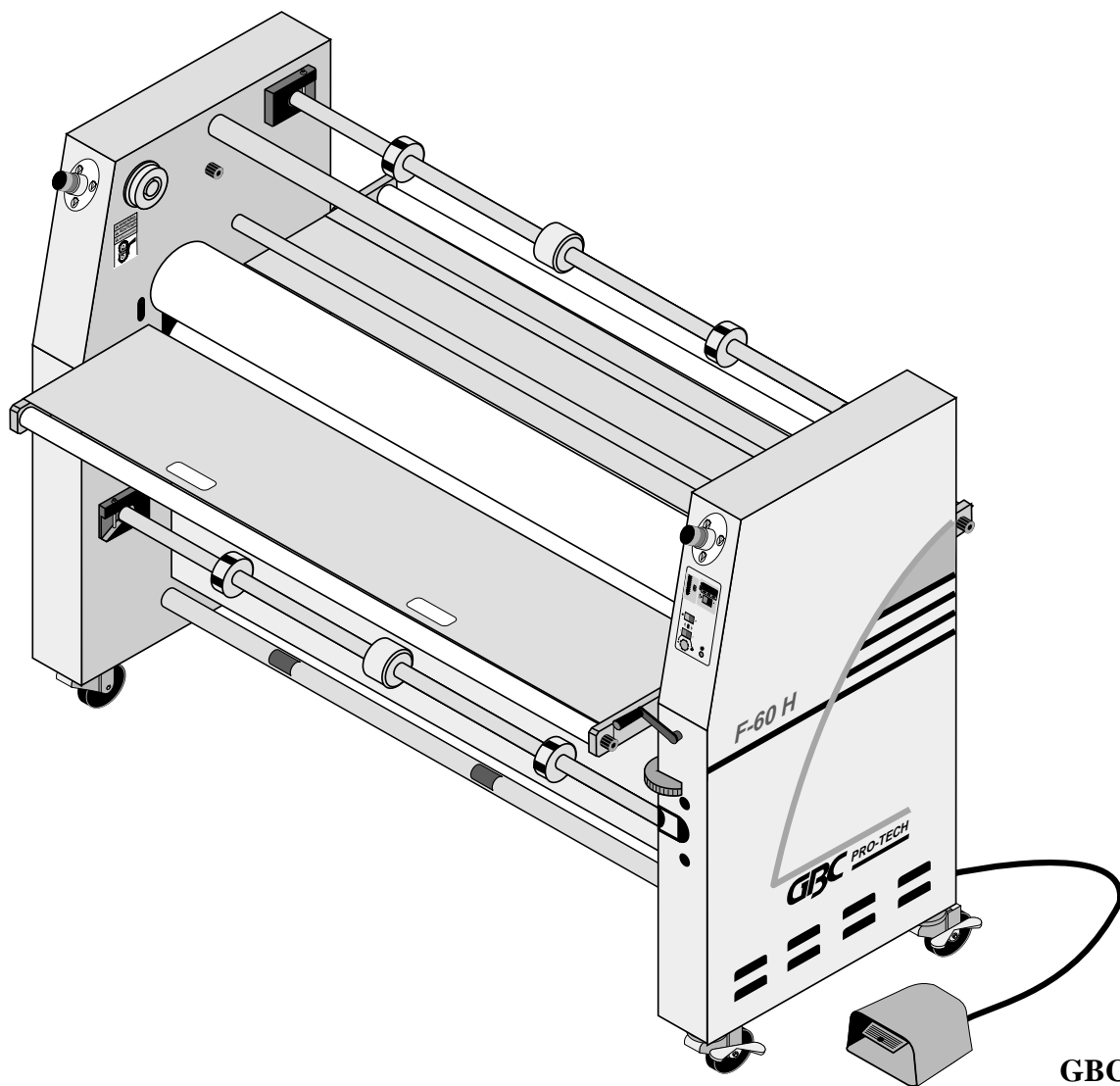

Revision : A  
Part number : 930 - 063

GBC Pro - Tech  
4151 Anderson Road  
DeForest, WI 53532  
Ph: ( 608 ) 246 - 8844  
Fx: ( 608 ) 246 - 8645







## Read Me File . . . . .

The information in this publication is provided for reference and is believed to be accurate and complete. General Binding Corporation is not liable for errors in this publication or for incidental or consequential damage in connection with the furnishing or use of the information in this publication, including, but not limited to, any implied warranty of fitness or merchantability for any particular use.

General Binding Corporation reserves the right to make changes to this publication and to the products described in it without notice. All specifications and information concerning products are subject to change without notice.

Reference in this publication to information or products protected by copyright or patent does not convey any license under the rights of General Binding Corporation or others. General Binding Corporation assumes no liability arising from infringements of patents or any other rights of third parties.

This publication is copyrighted © 2001 by General Binding Corporation. All rights reserved. The information contained in this publication is proprietary and may not be reproduced, stored, transmitted, or transferred, in whole or in part, in any form without the prior and express written permission of the General Binding Corporation.

The following information will explain how to move around within the electronic version of this publication. The hand will change to a pointer finger identifying hyperlinked areas. When moving from page to page, use  to return to the **first PAGE**, use  to advance to the **last PAGE**, use  to **go back one PAGE** and use  to **advance one PAGE**. When moving from view to view, use  to **return** to a previous **VIEW** and use  to **advance** to the next **VIEW**.

Should you find an error within this publication or would like to make a suggestion, please utilize the fax correspondence sheet following this read me file and fax it to the number provided. Your comments and help will ensure up to date information. Thank you.

*This page intentionally left blank.*

# Fax Correspondence

**Fax number :** ( 608 ) 246 - 8645

**Date :** \_\_\_\_\_

**To :** Technical Coordinator at GBC Protech  
4151 Anderson Road  
DeForest, WI 53532

**From :** \_\_\_\_\_

**Company :** \_\_\_\_\_

**Address :** \_\_\_\_\_

**Phone number :** ( \_\_\_\_\_ ) \_\_\_\_\_ **Fax number :** ( \_\_\_\_\_ ) \_\_\_\_\_

**Re :** F 60 H Operations and Maintenance Manual ( 930063A )

---

**Section #:** \_\_\_\_\_ **Page #:** \_\_\_\_\_

**Correction (s):** \_\_\_\_\_

\_\_\_\_\_  
\_\_\_\_\_  
\_\_\_\_\_  
\_\_\_\_\_

**Additional comments:** \_\_\_\_\_

\_\_\_\_\_  
\_\_\_\_\_  
\_\_\_\_\_  
\_\_\_\_\_  
\_\_\_\_\_  
\_\_\_\_\_

*This page intentionally left blank.*

---

# Table of Contents

## 1.0 Safety

|   |        |
|---|--------|
| 1.1 Symbols .....                         | 1 - 1  |
| 1.2 Safety precautions .....              | 1 - 2  |
| 1.3 Safety features .....                 | 1 - 3  |
| 1.4 Installation .....                    | 1 - 4  |
| 1.5 Operations .....                      | 1 - 7  |
| 1.6 Applications .....                    | 1 - 9  |
| 1.7 Troubleshooting .....                 | 1 - 10 |
| 1.8 Maintenance .....                     | 1 - 10 |
| 1.9 Decal explanation .....               | 1 - 12 |
| Figure 1.9.1 Safety label locations ..... | 1 - 14 |

## 2.0 Warranty

|  |       |
|--|-------|
| 2.1 Limited warranty information ..... | 2 - 1 |
| 2.2 Exclusions to the warranty .....   | 2 - 1 |

---

## 3.0 Specifications

|                               |       |
|-------------------------------|-------|
| 3.1 General .....             | 3 - 1 |
| 3.2 Consumables .....         | 3 - 2 |
| 3.3 Function .....            | 3 - 3 |
| 3.4 Electrical .....          | 3 - 4 |
| 3.5 Dimensions .....          | 3 - 5 |
| Figure 3.5.1 Dimensions ..... | 3 - 6 |

## 4.0 Installation

|   |       |
|---|-------|
| 4.1 Pre-installation check list .....     | 4 - 1 |
| Figure 4.1.1 Suggested floor layout ..... | 4 - 3 |
| 4.2 Know your machine .....               | 4 - 4 |
| 4.3 Unpacking .....                       | 4 - 5 |
| 4.4 Shrink wrapped .....                  | 4 - 5 |
| 4.5 Crated .....                          | 4 - 6 |
| 4.6 Accessory pack content .....          | 4 - 8 |

4.7 Installing levelers .....4 - 9

4.8 Leveling .....4 - 9

4.9 Connecting power .....4 - 11

4.10 Safety check .....4 - 13

## 5.0 Operations

5.1 Power ON/ OFF .....5 - 2

5.2 Control panel .....5 - 3

    Figure 5.2.1 Front control panel .....5 - 4

5.3 Set temperature .....5 - 5

5.4 Load/ unload film .....5 - 6

5.5 Unwind brake tension .....5 - 9

5.6 Rewind brake tension .....5 - 9

5.7 Setting the nip .....5 - 10

5.8 Footswitch .....5 - 12

---

## 6.0 Applications

|  |        |
|--|--------|
| 6.1 Helpful hints .....                              | 6 - 1  |
| 6.2 Temperature conversion chart .....               | 6 - 3  |
| 6.3 Charts and diagrams .....                        | 6 - 5  |
| Blank chart .....                                    | 6 - 6  |
| Blank diagram .....                                  | 6 - 7  |
| Blank diagram w/ roll to roll option .....           | 6 - 9  |
| Chart - Pre-coating substrates .....                 | 6 - 10 |
| Diagram - Pre-coating substrates .....               | 6 - 11 |
| Chart - Mounting an image .....                      | 6 - 12 |
| Diagram - Mounting an image .....                    | 6 - 13 |
| Chart - PSA decaling .....                           | 6 - 14 |
| Diagram - PSA decaling .....                         | 6 - 15 |
| Diagram - PSA decaling w/ roll to roll options ..... | 6 - 17 |
| Chart - Lo-Melt decaling .....                       | 6 - 18 |

---

|  |               |
|--|---------------|
| <b>Diagram - Lo-Melt decaling .....</b>  | <b>6 - 19</b> |
| <b>Diagram - Lo-Melt decaling w/ roll to roll options .....</b>                        | <b>6 - 21</b> |
| <b>Chart - Mounting a decal .....</b>  | <b>6 - 22</b> |
| <b>Diagram - Mounting a decal .....</b>  | <b>6 - 23</b> |
| <b>Chart - PSA single sided lamination ( sled ) .....</b>                              | <b>6 - 24</b> |
| <b>Diagram - PSA single sided lamination ( sled ) .....</b>                            | <b>6 - 25</b> |
| <b>Chart - PSA single sided lamination ( craft paper ).....</b>                        | <b>6 - 26</b> |
| <b>Diagram - PSA single sided lamination ( craft paper ) .....</b>                     | <b>6 - 27</b> |
| <b>Diagram - PSA single sided lamination ( craft paper ) w/ roll to roll option ..</b> | <b>6 - 29</b> |
| <b>Chart - PSA over-lamination of a mounted image .....</b>                            | <b>6 - 30</b> |
| <b>Diagram - PSA over-lamination of a mounted image .....</b>                          | <b>6 - 31</b> |
| <b>Chart - Lo-Melt over-lamination of a mounted image .....</b>                        | <b>6 - 32</b> |
| <b>Diagram - Lo-Melt over-lamination of a mounted image .....</b>                      | <b>6 - 33</b> |

## 7.0 Troubleshooting

7.1 Wave problems .....7 - 1

7.2 Film problems .....7 - 3

7.3 Machine problems .....7 - 4

7.4 Glossary .....7 - 5

## 8.0 Maintenance

8.1 Maintenance schedule .....8 - 1

8.2 Cleaning the rollers .....8 - 2

8.3 Clean cabinets and covers .....8 - 4

8.4 Clean the control panel .....8 - 4

8.5 Chain tensioning .....8 - 5

## 1.0 Safety



### CAUTION

Do not attempt to operate your Falcon 60 H laminator until you have read this section carefully!

Your safety, as well as the safety of others, is important to GBC Films Group. This section contains important safety information.

The following symbols are used throughout this manual to indicate **Information**, **Caution**, **Warning**, **Danger** and **Electrical Shock** conditions.

## 1.1 Symbols



### INFORMATION

Indicates helpful information that should be considered before, during, or after an action, step or procedure is given.



### CAUTION

Indicates a potentially hazardous situation which, if not avoided, could result in minor or moderate injury, or alerts against unsafe practices or alerts against actions which could damage the product.



### WARNING

Indicates a potentially hazardous situation which, if not avoided, could result in serious injury.



### DANGER

Indicates an imminently hazardous situation which, if not avoided, could result in death or serious injury.



### ELECTRICAL SHOCK

Indicates an electrical shock situation which, if not avoided, could result in serious paralysis of the body or death.

## 1.2 Safety precautions

The Falcon 60 H laminator has been designed with safety as a primary consideration; however, you must become thoroughly familiar with the controls, proper operation, proper service procedures and safety features of the laminator before using or servicing the unit.

The manual main roller lift mechanism used to provide downward pressure on the upper main roller is capable of producing forces greater than 400 pounds. This force is applied to any object presented in the opening ( called the nip ) between the two rollers.

Use care in lowering the upper laminating roller and know how to react quickly in an emergency. The main laminator roll up / down control is located on the right side of the machine within the front. Before turning the crank handle to set the **GAP** down, ensure that nothing is in the nip area.



### WARNING

**Keep hands and fingers clear of the laminator roller nip when adjusting nip. You can be CRUSHED or BURNED!**

In addition, the main laminating rollers of the Falcon 60 H can reach temperatures up to 200°F (100°C).



### DANGER

**At these temperatures there is a danger of severe burn if the rolls are touched during setup, operation or servicing.**

**The word qualified is defined below;**

## Qualified;

- Any engineer that has experience with electrical and mechanical design of lamination equipment. The engineers should be fully aware of all aspects of safety with regards to lamination equipment.

- Any commissioning or service engineer must be of competent nature, trained and qualified to GBC Films Group standards to fulfill that job. This person will have completed and passed the full service training course from GBC Pro-Tech.

- Any GBC Technician, GBC Specialist, and / or GBC Films Group Technician that has been through the GBC Pro-Tech service training course.

# 1.3 Safety features

The laminator is equipped with four emergency stops ( **E-STOP** ). Two are located at the front of the cabinets and two are at the rear of the cabinets.

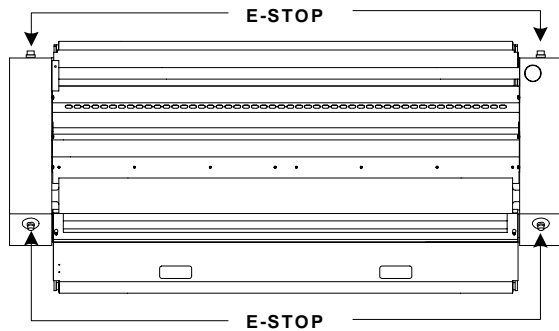

To engage an **E-STOP**, press down on any of the four. Any **E-STOP**, when engaged, removes power to the laminator.

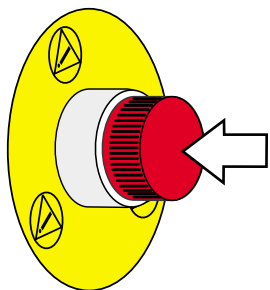

**INFORMATION**

The machine will only operate if all four **E-STOPS** are in the unlatched position.

To continue operation, all **E-STOPS** must be in the unlatched position. To reset, twist the **E-STOP** 1/4 turn counter clockwise.

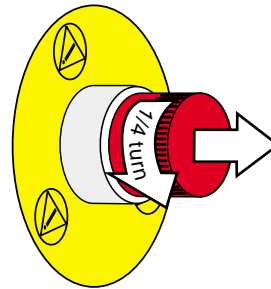

Press **RESET** located on the control side cabinet at the rear of the machine just above the main power on/off.

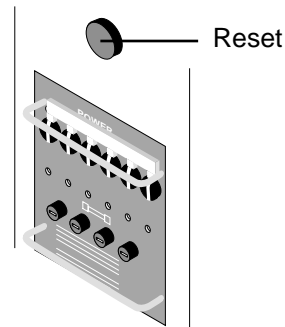

The nip area is protected by an electric photo-eye which shoots a beam in front of the nip across the width of the rollers. When this beam is broken, power to the drive motor is removed. The object must be removed to clear the photo-eye. The motor engage switch must be pressed again to continue motor operation.

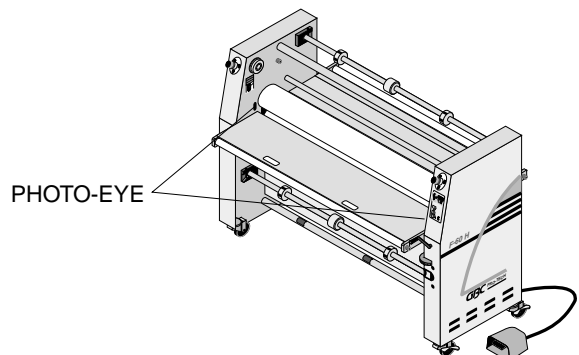

## 1.4 Installation

The following symbols are positioned at various points in **Section 4 Installation**.



### CAUTION

Failure to follow the pre-installation check list can result in damage to the laminator.



### WARNING

The operating environment must be free of dust, flammable liquids and vapors. You can be injured by inhaling chemical vapors.



### WARNING

Vapor build up or stored flammable liquids can cause a fire. Excessive dust can damage the laminator.



### CAUTION

Do not locate the Falcon 60 H where air is blowing directly on the machine. The air flow can cool the rolls unevenly and result in poor output quality.



### WARNING

The Falcon 60 H Laminator is a large and heavy piece of equipment. It is necessary to employ **LICENSED RIGGERS ONLY** to move the laminator. The laminator is not designed to be tipped up or sideways in any way. Such action disturbs the exact alignment of the rolling parts of the machine and requires extensive realignment. You can be crushed or seriously injured.



### INFORMATION

*ALL SHIPMENTS ARE EX-WORKS.* At our dock, title passes to the buyer. Please review your insurance coverage prior to shipment, as you are responsible for all subsequent freight charges and risks.



### INFORMATION

Before signing the Bill of Lading, you should be sure to inspect the crate and / or pallet for signs of damage or missing items; if applicable, make note of this on the Bill of Lading.



### WARNING

The unpacking process requires at least two people. You can be severely injured, crushed or cause damage to the laminator.

**INFORMATION**

Depending on the destination and customer preference, your machine may be shipped in various ways. The laminator may arrive shrink wrapped or in a plywood crate on a skid. Please follow the unpacking procedure that pertains to your method of shipment.

**CAUTION**

Do not allow the top to fall into the crate. It can damage the laminator.

**CAUTION**

Do not use a knife or other sharp object to remove the shrink wrap from around the laminator. You can cause irreparable damage to the rollers.

**INFORMATION**

Do not put packing screws on the floor. They can cause problems when trying to roll the laminator into position or you can become injured if stepped on.

**WARNING**

Do not attempt to move the laminator across anything other than a flat level surface without trained and qualified riggers. You can be crushed or seriously injured.

**CAUTION**

A second person must support the side labeled 5 in Figure 4.5.1 It can fall and damage the laminator or cause harm to you and others.

**INFORMATION**

GBC Film Group's warranty does not cover malfunction of the equipment due to mishandling and / or tipping. GBC Films Group bears no responsibility for personal injury or damage due to moving the laminator improperly.

**WARNING**

Do not attempt to use the ramps if they are not secured to the pallet. Ensure the pallet is on a flat even surface before attempting to roll the machine off.



**INFORMATION**

About recycling: The crate components can be reused for shipping the laminator again or can be disassembled and the wood and screws recycled. The shrink wrap is not recyclable, so it must be discarded.



**WARNING**

Follow the correct wiring diagram when supplying power to the laminator. If improperly connected, you can be seriously injured or cause damage to the laminator.



**CAUTION**

Do not move the leveling nut when securing the inside nut to the cabinet.



**WARNING**

Do not wear ties, loose fit clothing or dangling jewelry while operating or servicing the laminator. These items can get caught in the nip and choke you or you can be crushed or burned.



**INFORMATION**

You will need the control side cabinet cover off to connect the electrical power.



**WARNING**

If a safety feature is not working properly, contact your local service representative immediately.



**ELECTRICAL SHOCK**

Only a qualified electrician should connect power to the laminator. You can be severely shocked, electrocuted or cause a fire if power is improperly applied.



**CAUTION**

Do not use a hard substrate or a substrate with sharp edges. You may cause damage to the laminating rollers!

## 1.5 Operations

The following symbols are positioned at various points in **Section 5 Operations**.



**WARNING**

When the laminator rollers are in motion, keep hands and fingers away from the nip of the rollers. You may be **CRUSHED** or **BURNED**!



**WARNING**

Do not wear ties, loose fit clothing or dangling jewelry while operating or servicing the laminator. These items can get caught in the nip and choke you or you can be crushed or burned.



**WARNING**

When operating the laminator using the footswitch, keep hands and fingers away from the nip of the rollers. You may be **CRUSHED** or **BURNED**!



**INFORMATION**

The machine will only operate if all four emergency stops are unlatched and **RESET** has been pressed.



**WARNING**

Do not operate the laminator, except during web set up, without the front and rear feed tables in position.



**WARNING**

It is unsafe to sheet feed without the pressure plate properly placed on the front feed table.



**CAUTION**

Ensure the roll of laminate is loaded properly on the unwind shaft. Exposed adhesive should be facing away from the rollers. This will prevent hours of roll cleaning!



**WARNING**

Keep hands and fingers clear of the laminator roller nip when changing **GAP**. You can be **CRUSHED** or **BURNED**!



**INFORMATION**

The Poly-in/ Poly-out diagrams refer to the upper rolls of film only. The mount adhesive and craft papers are for reference only.



**WARNING**

Never leave the unwind shaft out of the unwind support saddle unless loading or unloading film.



**CAUTION**

Excess pressure can damage the laminating rollers. Always use the minimum roll pressure necessary to complete the task.



**CAUTION**

When using two rolls on the machine, ensure the film widths are identical. Exposed adhesive can cause complications.



**CAUTION**

Objects other than media, film or approved substrates, will cause irreparable damage to the rollers if caught in the nip.



**CAUTION**

Never use an open blade near the laminating rollers. You may cut the rollers or your self.



**CAUTION**

Sharp edges on a substrate should be filed smooth. Sharp edges can CUT the rollers!



**INFORMATION**

Always use the minimum amount of brake for the job.



**INFORMATION**

Excessive pressure will cause the substrate to bow or flatten.



**INFORMATION**

If more brake is needed, add an O-ring to the brake side of the rewind.



**INFORMATION**

Density of the substrate will determine the amount of pressure you may use.

## 1.6 Applications

The following symbols are positioned at various points in **Section 6 Applications**.



### WARNING

Do not wear ties, loose fit clothing or dangling jewelry while operating or servicing the laminator. These items can get caught in the nip and choke you or you can be crushed or burned.



### INFORMATION

Use film brake tension to control the separation point of the release liner.



### INFORMATION

Speeds and temperatures will affect the bond strength of Lo-Melt adhesives.



### INFORMATION

The mount adhesive must not exceed 1 in. the width of the substrate. If it does, you will experience complications with this application.



### INFORMATION

Excessive pressure will cause the substrate to bow or flatten.



### INFORMATION

Excessive brake tension may cause the image to curl. Always use the minimum amount of brake for the job.



### CAUTION

Excess pressure can damage the laminating rollers. Always use the minimum roll pressure necessary to complete the task.



### INFORMATION

Never stop the laminator when an image is within the nip of the rollers.



### INFORMATION

Laminates and papers should always be stored in a controlled environment.

## 1.7 Troubleshooting

The following symbols are positioned at various points in **Section 7 Troubleshooting**.



**WARNING**

Do not wear ties, loose fitting clothing or dangling jewelry while operating or servicing the laminator. These items can get caught in the nip and choke you or you can be crushed or burned.



**INFORMATION**

For optimal temperature settings of various laminates, contact your supplier or sales representative.

## 1.8 Maintenance

The following symbols are positioned at various points in **Section 8 Maintenance**.



**WARNING**

Do not wear ties, loose fit clothing or dangling jewelry while operating or servicing the laminator. These items can get caught in the nip and choke you or you can be crushed or burned.



**INFORMATION**

Improper maintenance, can result in poor output quality.



**ELECTRICAL SHOCK**

Remove power from the laminator before servicing. You can be severely shocked, electrocuted or cause a fire.



**INFORMATION**

Below is a recommended maintenance schedule. Before performing any of the steps listed, read through the procedures first. Please follow the instructions pertaining to the step you are performing.



**CAUTION**

Excessive pressure can destroy the silicone layer by pressing to hard or scrubbing too long in one spot.



**ELECTRICAL SHOCK**

Remove power from the laminator before cleaning. You can be severely shocked, electrocuted or cause a fire.



**CAUTION**

Exercise care when cleaning the laminating rollers with 80% isopropyl alcohol:

- Use only in a well ventilated area
  - Wear rubber gloves
  - Use only on cool rolls



**ELECTRICAL SHOCK**

Do not use liquid or aerosol cleaners on the laminator. Do not spill liquid of any kind on the laminator. You can be severely shocked, electrocuted or cause a fire. Use only a damp cloth for cleaning unless other wise specified.

**CLEANING HEATED ROLLERS CAN IGNITE THE FUMES!**



**WARNING**

Remove ALL power to the laminator before removing any cabinet covers. You may be shocked or electrocuted!



**CAUTION**

Do NOT pick or pull heat activated adhesive off the rolls when they are cold. You can cause irreparable damage to the laminating rolls.



**WARNING**

Always practice lock out/ tag out procedures when performing any type of service or maintenance work on the machine.



**WARNING**

When operating the laminator using the footswitch, keep hands and fingers away from the nip of the rollers. You may be CRUSHED or BURNED!



**INFORMATION**

The motor controls the tension of the both chains. If one chain is still too loose, a half link may be removed.

# 1.9 Label locations

Posted at various locations on the Falcon 60 H Laminator are important safety labels. **Pay careful attention to these labels at all times!** Figure 1.12.1 illustrates the location of each of these labels.



**Hazardous Voltage:** Do not open these cabinets. This machine is to be serviced only by trained and authorized personnel.

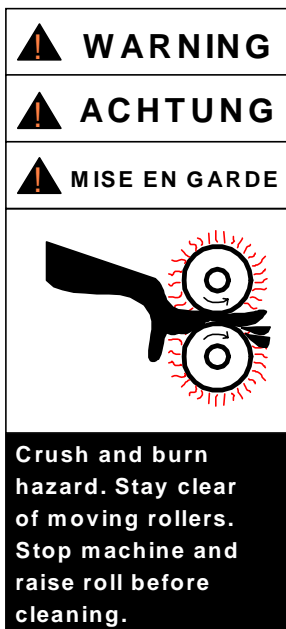

**Roller Pinch Point:** Keep hands and fingers away. You may be crushed and/ or burned.



**Moving Parts:** Keep hands and fingers away. You may be crushed and/ or cut.



**Read Manual:** Read and understand the Operations Manual before attempting to run this machine.

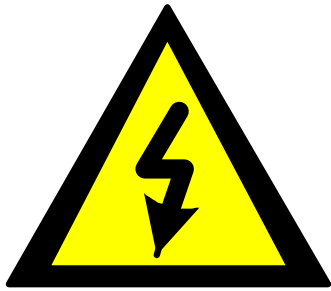

Refer to Figure 1.9.1 Label Placement illustrates the location of each of these labels.

**Electrical Shock:** Live voltage present. Exercise extreme caution. You may be electrocuted!

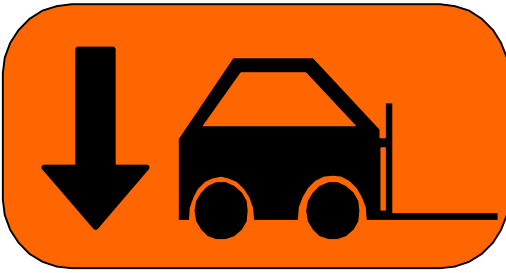

**Lift Here:** This point may be used as a lifting point. If ignored, damage will occur to the laminator.

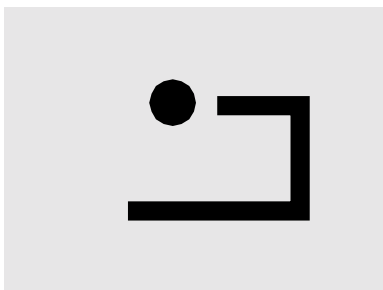

**Reset:** Machine reset. Press after initiating power to the laminator or after an E-STOP or E-CABLE has been engaged then reset.

Figure 1.9.1 Safety label locations

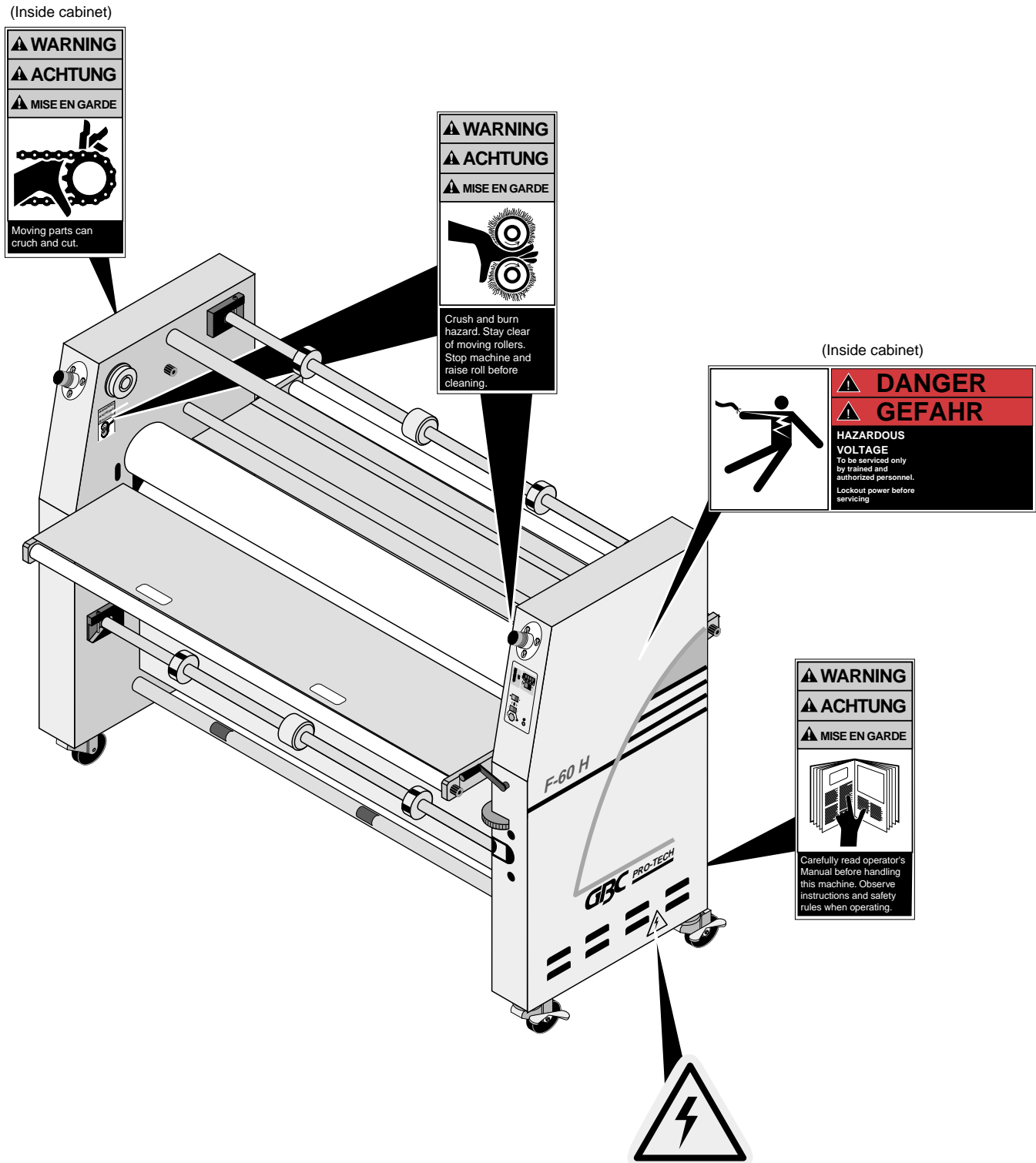

## 2.0 Warranty

GBC Films Group warrants the equipment sold is free from defects in material and workmanship for a period of **one ( 1 ) year parts ( excludes normal wear items ) and 90 days labor** from the date of installation. This warranty is the only warranty made by GBC Films Group and cannot be modified or amended.

GBC Films Group's sole and exclusive liability and the customer's sole and exclusive remedy under this warranty shall be, at GBC Films Group's option, to repair or replace any such defective part or product. These remedies are only available if GBC Films Group's examination of the product discloses to GBC Films Group's satisfaction that such defects actually exist and were not caused by misuse, neglect, attempt to repair, unauthorized alteration or modification, incorrect line voltage, fire, accident, flood, or other hazard.

### 2.1 Limited Warranty

This warranty specifically does not cover damage to the laminating rollers caused by knives, razor blades, other sharp objects, failure caused by adhesives or improper use of the machine. Warranty repair or replacement does not extend the warranty beyond the initial one year period from the date of delivery.



**CAUTION**

Unauthorized customer alterations will void this warranty.

**THE WARRANTY MADE HEREIN IS IN LIEU OF ALL OTHER WARRANTIES, EXPRESS OR IMPLIED, INCLUDING ANY WARRANTY OR MERCHANTABILITY OR FITNESS FOR A PARTICULAR PURPOSE. GBC FILMS GROUP WILL NOT BE LIABLE FOR PROPERTY DAMAGE OR PERSONAL INJURY ( UNLESS PRIMARILY CAUSED BY ITS NEGLIGENCE ), LOSS OF PROFIT OR OTHER INCIDENTAL OR CONSEQUENTIAL DAMAGES ARISING OUT OF THE USE OR INABILITY TO USE THE EQUIPMENT.**

### 2.2 Exclusions to the Warranty

**This warranty specifically does not cover;**

1. Damage to the laminating rollers caused by knives, razor blades, other sharp objects or failure caused by adhesives.
2. Damage to the machine caused by lifting, tilting and / or any attempt to position the machine other than rolling on the installed castors on even surfaces.
3. Improper use of the machine.
4. Damage due from unqualified person(s) servicing the machine.

## *Qualified*

- Any engineer that has experience with electrical and mechanical design of lamination equipment. The engineers should be fully aware of all aspects of safety with regards to lamination equipment.

- Any commissioning or service engineer must be of competent nature, trained and qualified to GBC Films Group standards to fulfill that job. This person will have completed and passed the full service training course from GBC Pro-Tech.

- Any GBC Technician, GBC Specialist, and / or GBC Films Group Technician that has been through the GBC Pro-Tech service training course.

## 3.0 Specifications

Specifications provide all of the technical data for the Falcon 60 H Laminator.

### 3.1 General

**Description:**

- Cost efficient, wide format color finisher for the sheet fed ink jet market. The Falcon 60 H is a self standing, bi-directional cold mounter and laminator with the ability to run Lo-Melt overlaminate.

**Features:**

- Two unwinds ( 1 upper, 1 center/ front )
- One rewind ( upper front )
- Infeed and oufeed tables
- Footswitch
- Front and rear table idlers
- Bi-directional system
- Four E-STOPS
- Photo-eye nip protection
- Roll to roll capability ( option)

**Applications:**

- Single sided lamination
- Mounting
- Decaling
- Low melt film

## 3.2 Consumable

**Film types:**

- Pressure sensitive laminates
- Pressure sensitive adhesives
- Low melt laminates

**Film diameters:**

- Up to a 8 in. roll diameter ( 20.3 cm )

**Core size:**

- 3 in. core standard ( 7.62 cm )
- 2-1/4 in. optional ( must have optional core adapters )  
( 5.72 cm )

**Film widths:**

- 62 in. Pressure sensitive ( 162.6 cm )
- 60 in. Low Melt ( 157.8 cm )

**Paper widths:**

- 62 in. maximum paper width ( 157.8 cm )

**Mounting thickness:**

- Up to 1 in. thick ( 2.54 cm ) either direction

**Safety:**

- Designed to UL safety standards

### 3.3 Function

**Speed:** • 0 - 16 ft / min ( 0 - 4.6 m / min )

**Motor:** • 2-1/4 horse power drive motor  
• Bi-directional D.C. motor

**Heating capabilities:** • 68°F - 200°F ( 20°C - 93°C )

**Controls:** • Front control panel  
• Footswitch

**Roll design:** • High release silicone rollers

## 3.4 Electrical

**United States and Canada:** • 230 ~ 240 VAC, 50/60 Hz, single phase, 40 amps

**B.T.U. output:** • 18,520 B.T.U. / hour

**Heater wattages:** • 5429 watts per heater @ 240 vac

**Amperage draw:** • No heat, motor only : 1 - 3 amps  
• Top heat and motor : 25 - 30 amps

**D/C voltage used:** • 24 vdc

**A/C voltage used:** • 230~ 240 vac ( minimum )

## 3.5 Dimensions

### Weight:

**Uncrated:** • 1350 lbs. ( 612 kg. )

**Crated:** • 1625 lbs. ( 737 kg. )

### Dimensions

**Uncrated:** • 80 in. (L) x 38.5 in. (W) x 57 in. (H)  
( 203 cm (H) x 98 cm (W) x 145 cm (L) )  
Refer to **Figure 3.5.1 Dimensions**

**Crated** • 90 in. (L) x 44 in. (W) x 68 in. (H)  
( 229 cm (H) x 112 cm (W) x 173 cm (L) )

**Nip Height:** • 38 in. ( 96.5 cm )

Figure 3.5.1 Dimensions

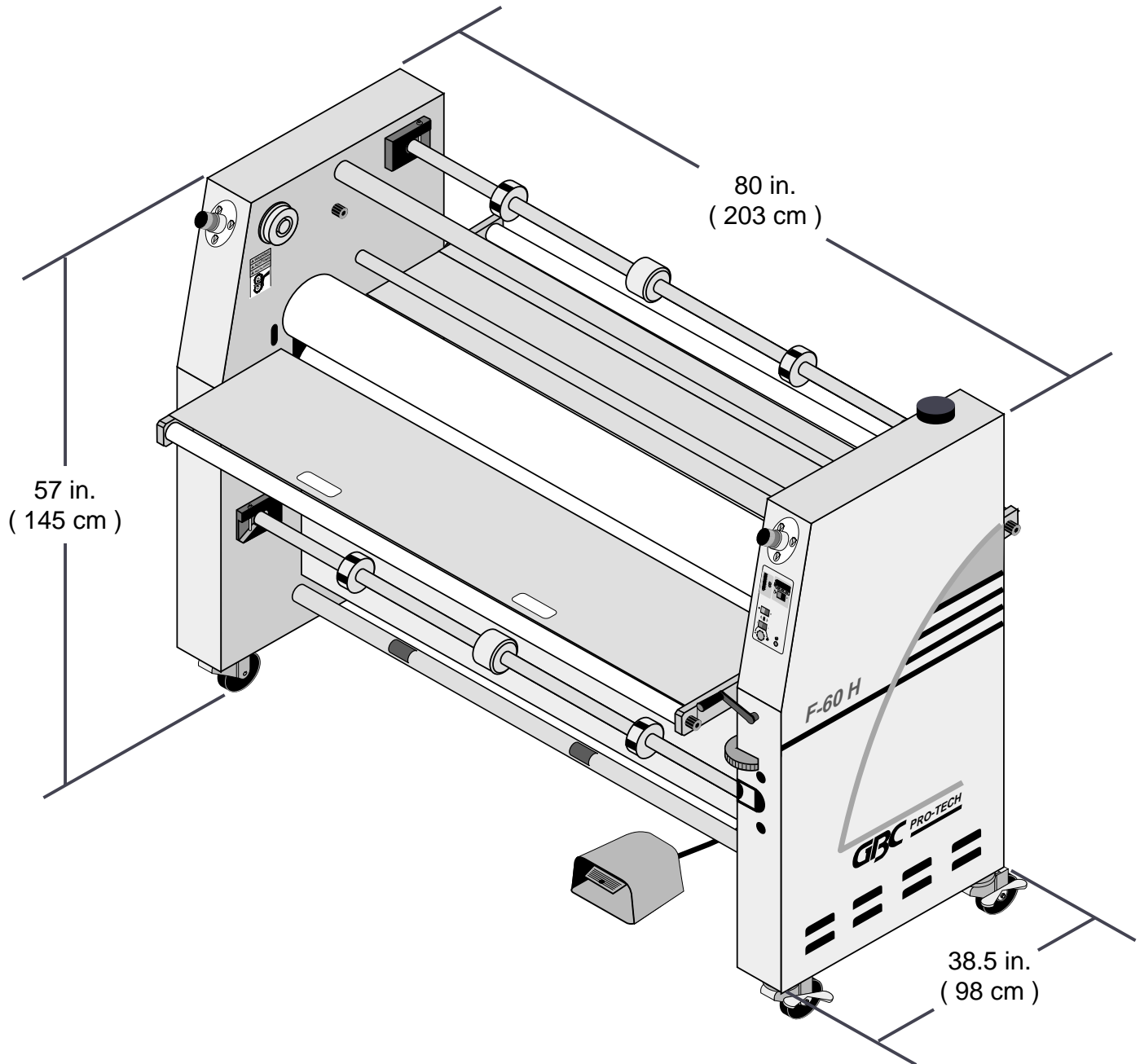

## 4.0 Installation

GBC Films Group is committed to a program of ongoing product improvement. As a result, we are providing these instructions so you can insure that your new Falcon 60 H Laminator is properly and securely unpacked, moved, and installed. Installation should be performed by a qualified technician.

Before a Falcon 60 H Laminator can be installed, there are a few requirements that must be met. Make certain that each of the requirements listed in the following pre-installation checklist are met before beginning installation.



### CAUTION

Failure to follow the pre-installation check list can result in damage to the laminator.

### 4.1 Pre-installation

- Are doorways and hallways wide enough for the laminator to be moved to the installation site?
- Is there ample room for the laminator?
- A work area must be established that allows for operation in both the front and rear of the laminator and provides space for efficient material flow. **Figure 4.1.1** illustrates a typical machine area layout.



Is the environment appropriate for the laminator? The laminator requires a clean, dust and vapor free environment to operate properly. Do not locate it where there is air blowing directly on the machine.



Have you contacted a certified electrician to both wire the laminator and ensure that adequate power is being supplied, having the appropriate capacity, over current protection and safety lockouts are available?



### WARNING

The operating environment must be free of dust, flammable liquids and vapors. You can be injured by inhaling chemical vapors.



### WARNING

Vapor build up or stored flammable liquids can cause a fire. Excessive dust can damage the laminator.



### CAUTION

Do not locate the Falcon 60 H where air is blowing directly on the machine. The air flow can cool the rolls unevenly and result in poor output quality.

- The Falcon 60 H requires single phase, 230 to 240 vac, 50/ 60 Hz, 40 amp service. No other type of connection is permitted.

**WARNING**

**The Falcon 60 H Laminator is a large and heavy piece of equipment. It is necessary to employ LICENSED RIGGERS ONLY to move the laminator. The laminator is not designed to be tipped up or sideways in any way. Such action disturbs the exact alignment of the rolling parts of the machine and requires extensive realignment. You can be crushed or seriously injured.**

For instructions on how to connect power, proceed to **4.9 Connecting power** in this section.

Figure 4.1.1 Suggested Floor Layout

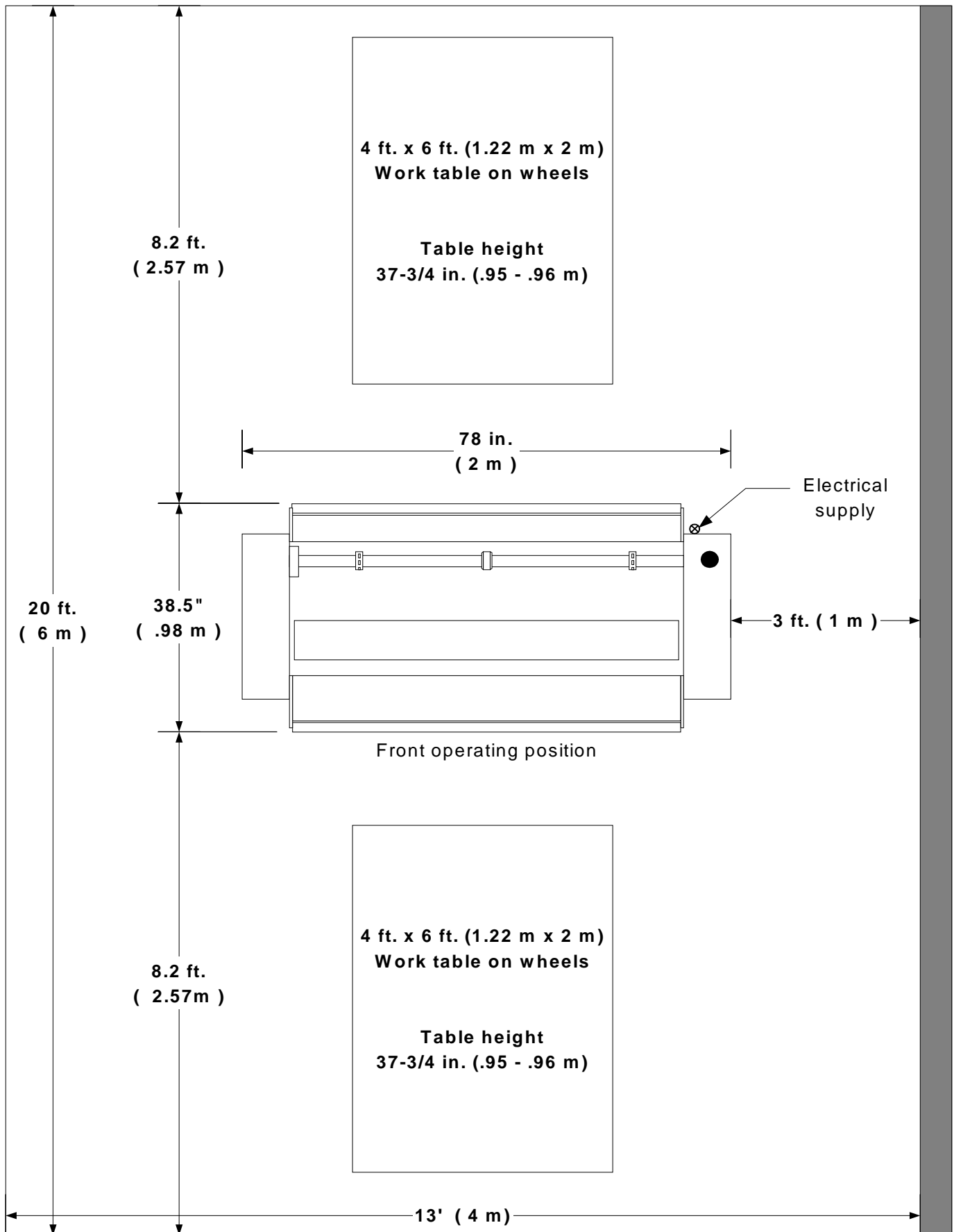

## 4.2 Know your machine

Before performing any procedure within this manual, it is recommended that you take time to know the parts of your new machine.

**Figure 4.2.1 The laminator**

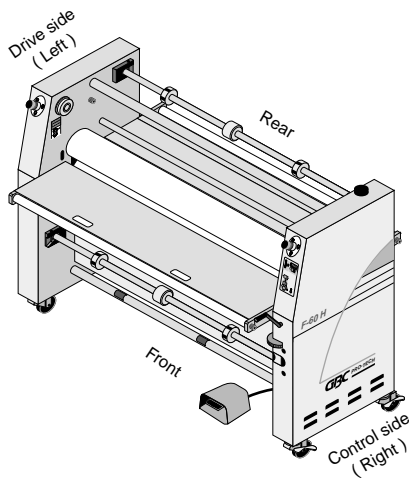

**Figure 4.2.2 Safety and controls**

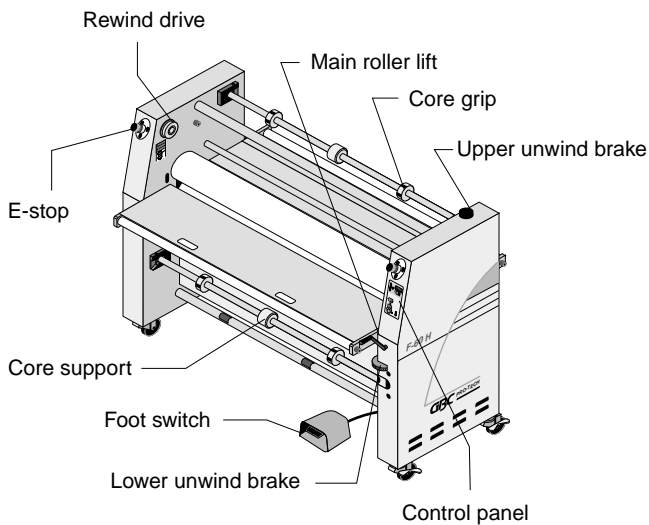

**Figure 4.2.3 Idlers and unwinds**

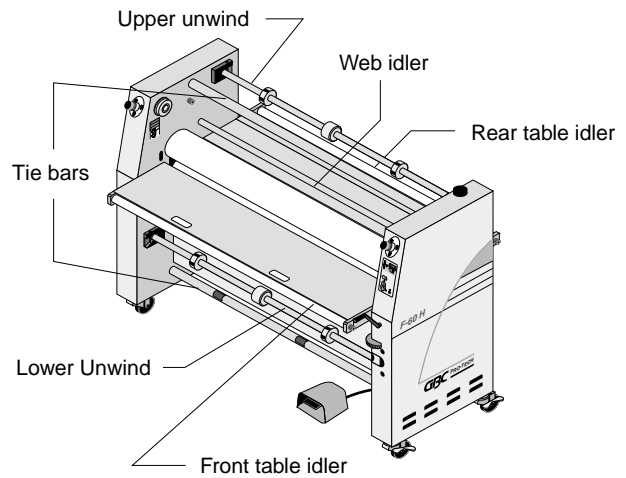

**Figure 4.2.4 Misc.**

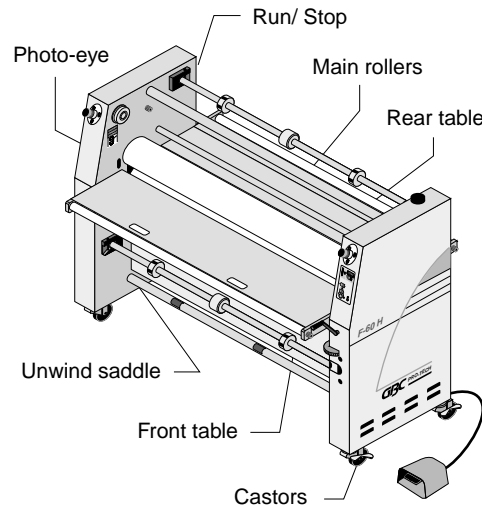

**Figure 4.2.5 Power**

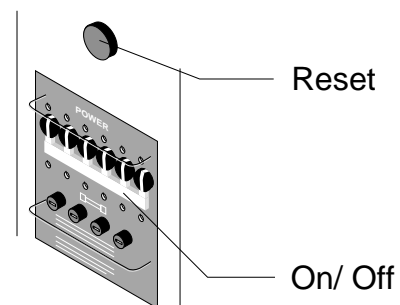

## 4.3 Unpacking



### INFORMATION

**ALL SHIPMENTS ARE EX-WORKS.** At our dock, title passes to the buyer. Please review your insurance coverage prior to shipment, as you are responsible for all subsequent freight charges and risks.



### INFORMATION

Before signing the Bill of Lading, you should be sure to inspect the crate and / or pallet for signs of damage or missing items; if applicable, make note of this on the Bill of Lading.



### INFORMATION

Depending on the destination and customer preference, your machine may be shipped in various ways. The laminator may arrive shrink wrapped or in a plywood crate on a skid. Please follow the unpacking procedure that pertains to your method of shipment.



### WARNING

The unpacking process requires at least two people. You can be severely injured, crushed or cause damage to the laminator.

With regards to your shipping methods, use one of the following procedure described to safely and properly unwrap / uncrate your laminator.

## 4.4 Shrink Wrapped

a) Inspect the machine for any obvious shipping damages upon receipt. Report any damage to your carrier.

b) Carefully unwrap the shrink wrap from around the laminator.



### CAUTION

Do not use a knife or other sharp object to remove the shrink wrap from around the laminator. You can cause irreparable damage to the rollers.

c) Carefully wheel your Falcon 60 H Laminator with a second person to the installation site.



### WARNING

Do not attempt to move the laminator across anything other than a flat level surface without trained and qualified riggers. You can be crushed or seriously injured.

## 4.5 Crated

## *To uncrate the laminator*



### WARNING

The Falcon 60 H Laminator is a large and heavy piece of equipment. It is necessary to employ **LICENSED RIGGERS ONLY** to move the laminator. The laminator is not designed to be tipped up or sideways in any way. Such action disturbs the exact alignment of the rolling parts of the machine and requires extensive realignment. You can be crushed or seriously injured.

- a) Remove the top of the crate and then the sides in the order shown in **Figure 4.5.1**



### CAUTION

Do not allow the top to fall into the crate. It can damage the laminator.



### INFORMATION

GBC Film Group's warranty does not cover malfunction of the equipment due to mishandling and / or tipping. GBC Films Group bears no responsibility for personal injury or damage due to moving the laminator improperly.



### INFORMATION

Do not put packing screws on the floor. They can cause problems when trying to roll the laminator into position or you can become injured if stepped on.

## *Tools required*

- # 2 Phillips head screwdriver
- 7/8" open end wrench or adjustable wrench
- Crow bar
- A second person



### CAUTION

A second person must support the side labeled 5 in Figure 4.5.1 It can fall and damage the laminator or cause harm to you and others.

Figure 4.5.1 Disassembling of the crate

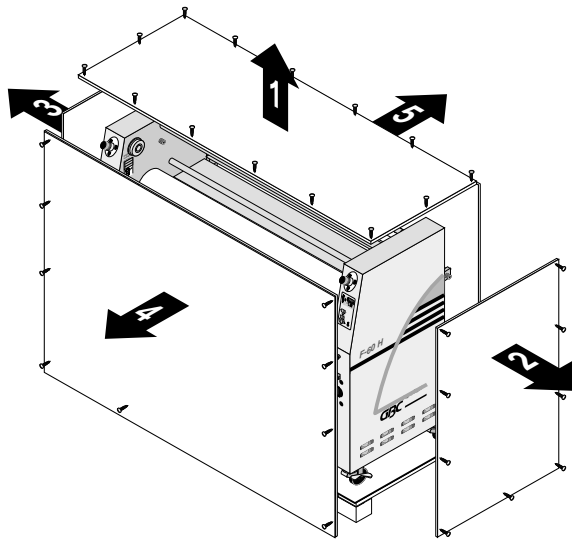

**Removing the shrink wrap**

- a) Gently unwrap the shrink wrap from around the laminator.



**CAUTION**

Do not use a knife or other sharp object to remove the shrink wrap from around the laminator. You can cause irreparable damage to the rollers.

- b) Move all packing materials to a safe distance.

**Moving the laminator**

- a) Have the laminator rolled off the skid and placed on the floor by licensed riggers. The ramps included with the laminator can be secured utilizing screws removed from the disassembled crate. **Figure 4.5.2** illustrates positioning of the ramps.



**WARNING**

Do not attempt to use the ramps if they are not secured to the pallet. Ensure the pallet is on a flat even surface before attempting to roll the machine off.

**Figure 4.5.2 Positioning of the ramps**

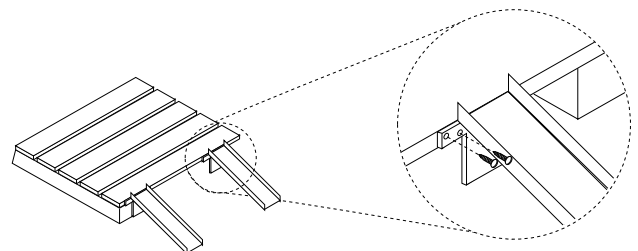

- b) Remove any plastic strapping and/or packing paper taped to the rollers.

**CAUTION**

**Do not use a knife or other sharp object to remove the shrink wrap from around the laminator. You can cause irreparable damage to the rollers.**

c) Remove all packing materials to a safe distance from the laminator and dispose of properly.

d) Use two people to carefully roll the laminator to the desired location.

**INFORMATION**

**About recycling: The crate components can be reused for shipping the laminator again or can be disassembled and the wood and screws recycled. The shrink wrap is not recyclable, so it must be discarded.**

## 4.6 Accessory pack

Once the Falcon 60 H Laminator has been unpacked and moved into final position, open the accessory pack and verify the contents.

### *Accessory Pack contents*

- One Fuse, 250 V, 20 amp ( 186 - 135 )
- Two Fuses, 2,5 amp ( 186 - 220 )
- One fuse, 0.5 amp ( 186-016 )
- One Operators Manual ( 930 - 063 )
- One Towel ( 475 - 950 )
- One Zippy knife ( 475 - 620 )
- One strain relief for main power ( 175-201 )
- One rubber cement pad ( 930320 )
- One crank handle ( 629-018 )
- One O-ring ( 480 - 005 )
- Four leveling pads ( 470 - 101 )
- One T-handle, 1/4 in. ( 475 - 210 )
- One roll of masking tape ( 475 - 000 )
- One crank handle ( ??? - ??? )
- One BHCS ( floor stock item )

If you are missing any of the items listed above, contact your local service technician or sales representative.

#### **Contacts:**

**GBC Parts ( 800 ) 790 - 7787**

**GBC Europe parts 33 - 45 - 535 - 7676**

## 4.7 Installing levelers

Leveling of the machine is a customer option. If you choose not to level the laminator and you encounter output problems, please level the machine and try your application again before calling for technical support.

### *Tools required*

- ( 2 ) 3/4" open end wrenches
- Four leveling pads  
( from the accessory pack )

- a) Verify that the laminator has sufficient room around it to load film, walk around and to be serviced if necessary.
- b) Place one leveling pad on each of the four leveling bolts on the laminator.

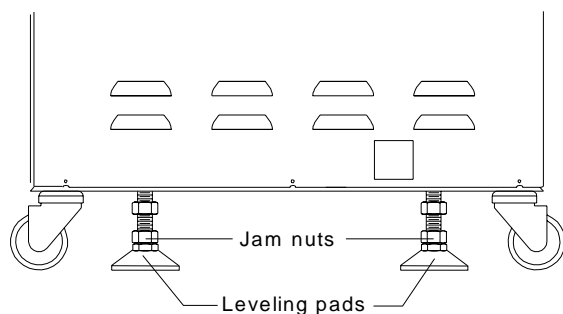

- c) Use a 3/4 in. open end wrench to secure the jam nut against the leveling pad.

## 4.8 Leveling

Leveling of the laminator is very important in the way the machine performs. Leveling is crucial to the tram ( tracking ) of the materials through the machine.

### *Tools required*

- ( 2 ) 3/4 in. open end wrenches
- 1/8 in. allen wrench
- Level
- A second person

- a) With a 1/8 in. allen wrench, remove the drive side and control side cabinet covers by;

- 1) Loosen the three screws along the bottom.
- 2) Remove the seven screws along the top and sides of the cover.

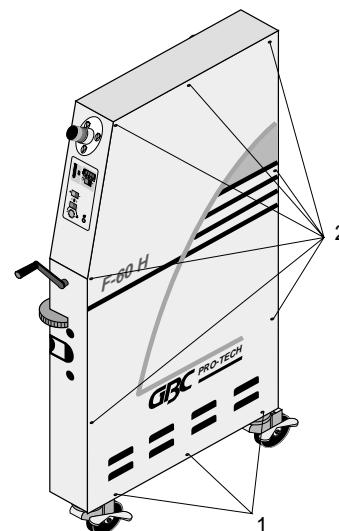

- b) Loosen the nut on the inside of both cabinets securing the leveling bolt with a 3/4 in. wrench.

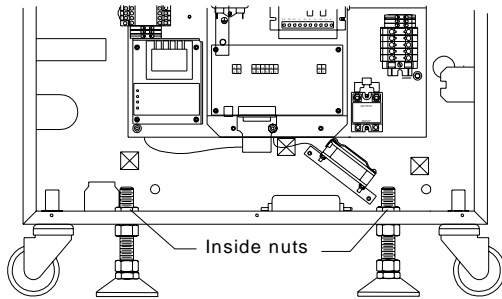

- e) Position the level on the top of the drive side cabinet.

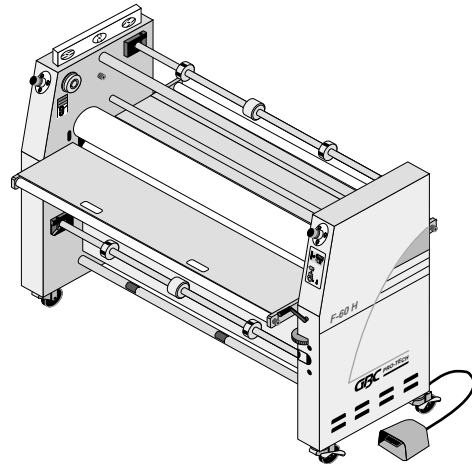

- c) Position the level on the top of the control side cabinet.

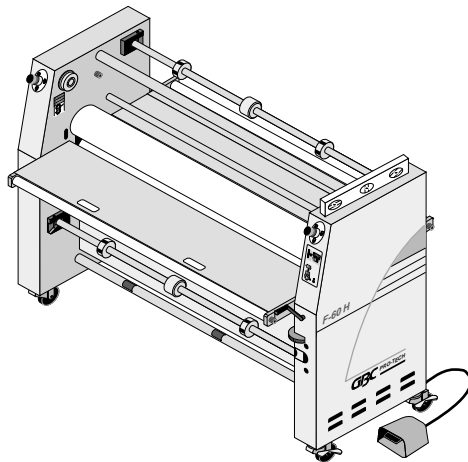

- f) Level the drive side from front to back by turning the leveling nut clockwise to raise or counter clockwise to lower.

- g) Position the level center of the upper tie bar.

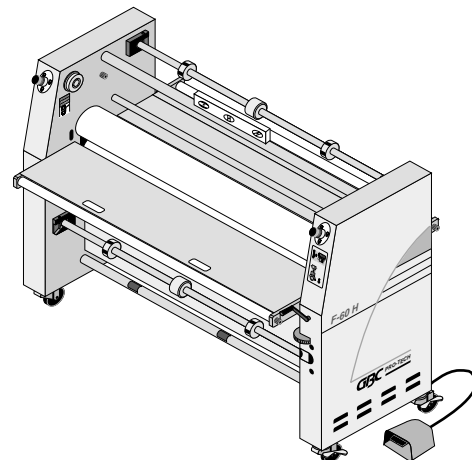

- d) Level the control side from front to back by turning the leveling nut clockwise to raise or counter clockwise to lower.

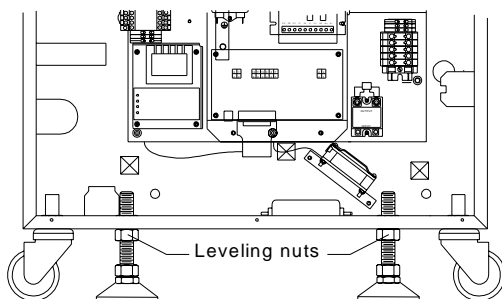

- h) Level the laminator from drive side to control side by turning the leveling nut clockwise to raise or counter clockwise to lower.

i) Verify that all three points are still leveled.

j) Hold the leveling nut in place with a 3/4 in. open end wrench while you secure the inside nut to the cabinet. Do this for both sides.

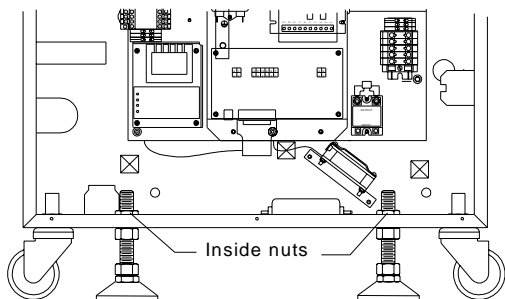

**CAUTION**

**Do not move the leveling nut when securing the inside nut to the cabinet.**

k) Replace the drive side cabinet cover at this time.



**INFORMATION**

**You will need the control side cabinet cover off to connect the electrical power.**

## 4.9 Connecting power



**ELECTRICAL SHOCK**

**Only a qualified electrician should connect power to the laminator. You can be severely shocked, electrocuted or cause a fire if power is improperly applied.**

### *Tools required*

- 1/8 in. allen wrench
- # 2 phillips head screw driver
- Multi meter

a) Ensure the power at the junction box is in the **OFF** position.

b) Feed the power cable through the main power strain relief from the accessory pack, then through the hole provided below the circuit breaker on/ off.

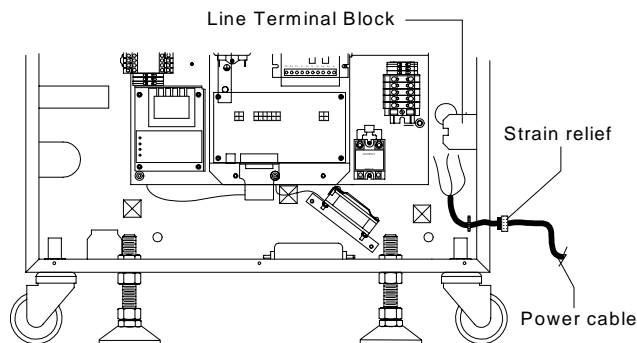

c) Connect the wires to the Line Terminal Block (LTB) as illustrated below.

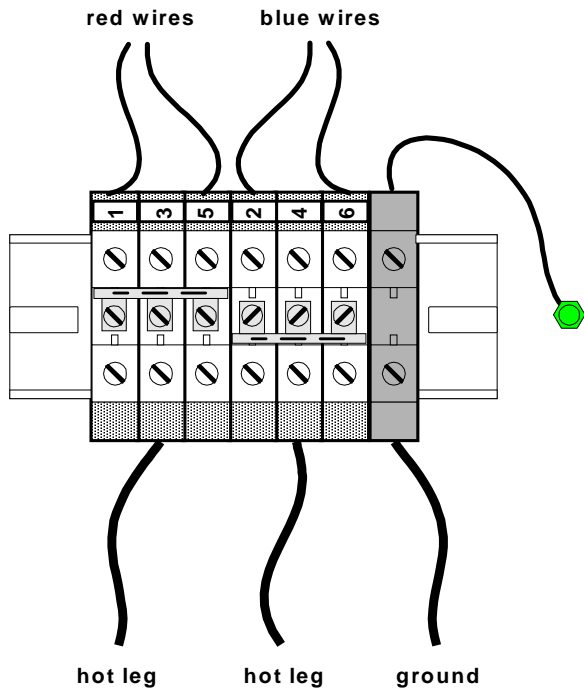

f) Verify line voltage with regards to the type of power being supplied to the laminator at the line terminal block.

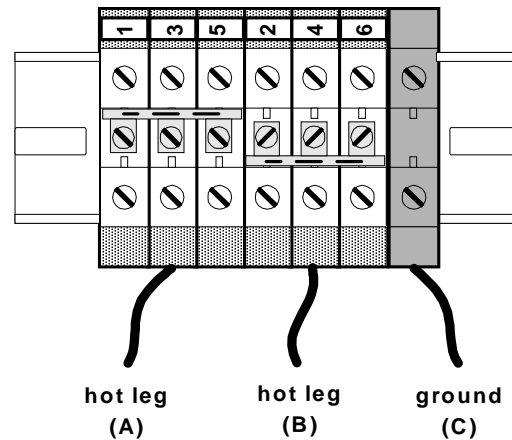

• (A) - (B) = 230 ~ 240 VAC

• (A) - (C) = 115 ~ 120 VAC

• (B) - (C) = 115 ~ 120 VAC



**WARNING**

Follow the correct wiring diagram when supplying power to the laminator. If improperly connected, you can be seriously injured or cause damage to the laminator.

d) Secure the main power strain relief to the cabinet.

e) Turn the junction box power to the ON position.

g) Replace the control side cabinet cover.

h) Turn the On/ Off to the “ON” position by flipping the handle to the up position and press reset.

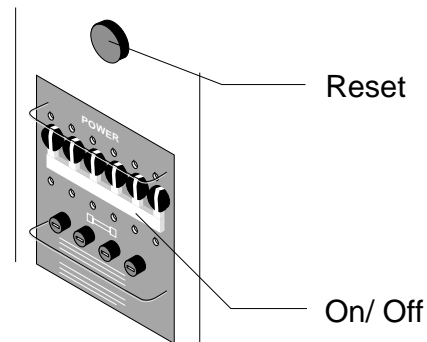

# 4.10 Safety check

## E-STOPs

The safety check will ensure that all safety devices and interlocks are functioning properly.

This procedure describes how to check one **E-STOP** and the **PHOTO-EYE**. Repeat the steps for the remaining three **E-STOPs**. **ALL SAFETY FEATURES MUST BE CHECKED!**



**WARNING**

Do not wear ties, loose fit clothing or dangling jewelry while operating or servicing the laminator. These items can get caught in the nip and choke you or you can be crushed or burned.



**WARNING**

If a safety feature is not working properly, contact your local service representative immediately.

**Contacts:**

**GBC National Service: ( 800 ) 790 - 7787**

**My service rep: \_\_\_\_\_**

**a) Turn MAIN POWER to ON .**

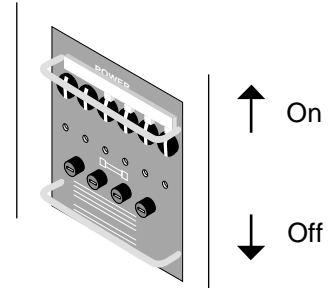

**b) Press RESET . The power indicator on the front control panel will be illuminated.**

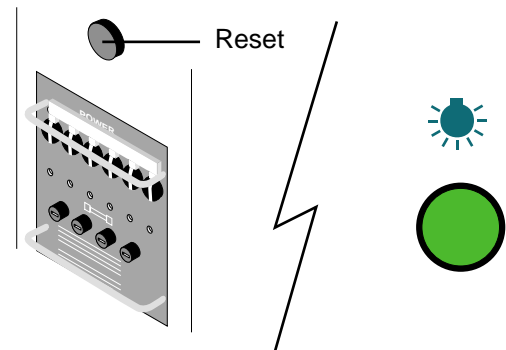

**c) Press the motor direction to FORWARD.**

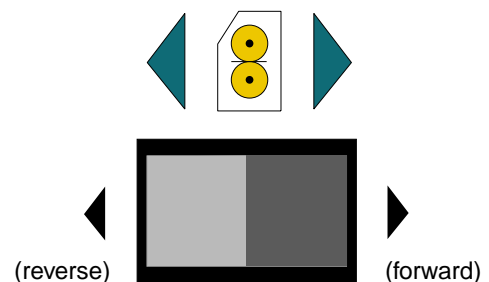

d) Rotate the speed dial to a setting greater than 1.

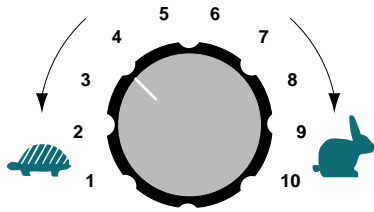

e) Press the motor engage/ disengage to **ENGAGE**.



f) Press the temperature on/off to **ON**.



g) Press one of the four **E-STOPS**.

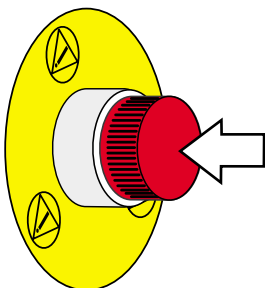

h) The bottom main roller stops turning, the power indicator light goes out, the display on the temperature controller unit goes out.

i) Turn the **E-STOP** 1/4 turn counter clockwise to unlatch.

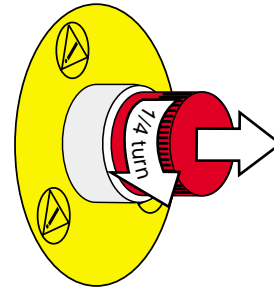

j) Repeat steps b) through i) for the remaining three **E-STOPS**.

## PHOTO-EYE

a) Cut a piece of 1/2 inch ( 1.3 cm ) thick foam board to 4 inches x 6 inches. ( 10 cm x 15 cm ) This piece will be referred to as the “finger board”.



**CAUTION**

**Do not use a hard substrate or a substrate with sharp edges. You may cause damage to the laminating rollers.**

b) Ensure all E-STOPS are in the unlatched position and remove the pressure plate from the front feed table.

c) If the power indicator on the control panel is not illuminated, press **Reset**.

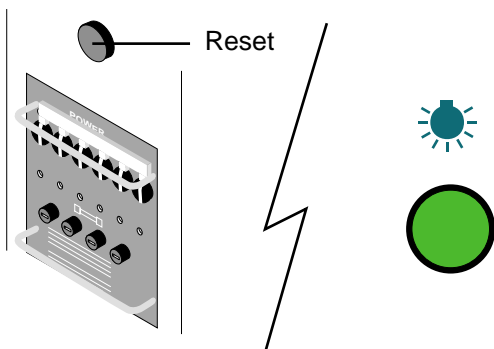

d) Set the motor direction to **FWD**.

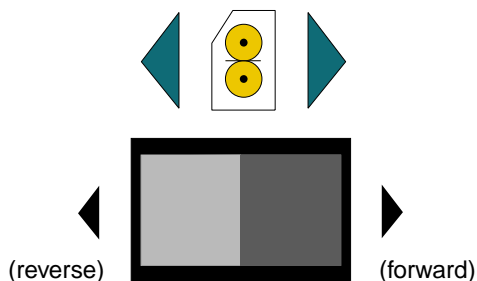

e) Lower the main roller to initial contact ( one bar on the pressure display is illuminated ).

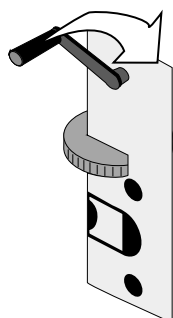

f) Press the motor engage/ disengage to **ENGAGE**.



g) Slide the “finger board” on the front feed table towards the nip about 10 in. ( 25 cm ) from the control side.

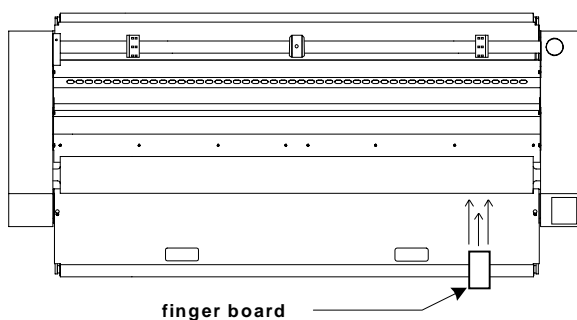

h) The rollers should stop just before the finger board can enter the roller nip.

i) Slide the finger board back away from the rollers nip. Press the motor engage/ disengage to **ENGAGE**.



j) If the finger board comes in contact with the rollers while they are turning, contact your service representative to adjust the **PHOTO-EYES**.

k) Slide the “finger board” towards the roller nip about center of the front feed table.

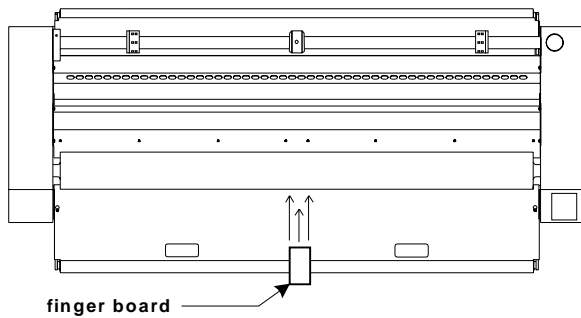

l) The rollers should stop just before the finger board can enter the roller nip.

m) Slide the finger board back away from the rollers nip. Press the motor engage/ disengage to **ENGAGE**.



n) If the finger board comes in contact with the rollers while they are turning, contact your service representative to adjust the **PHOTO-EYES**.

o) Slide the “finger board” on the front feed table towards the nip about ten in. ( 25 cm ) from the control side.

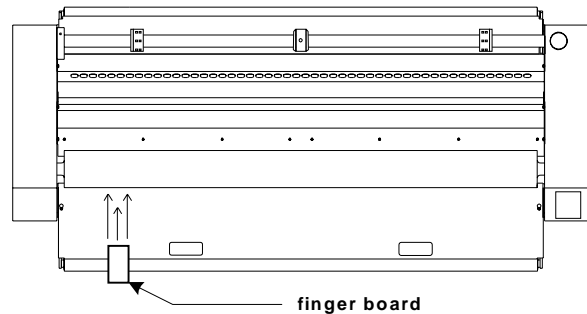

p) The rollers should stop just before the finger board can enter the roller nip.

q) Slide the finger board back away from the rollers nip.

r) If the finger board comes in contact with the rollers while they are turning, contact your service representative to adjust the **PHOTO-EYES**.

s) Raise the main roller.

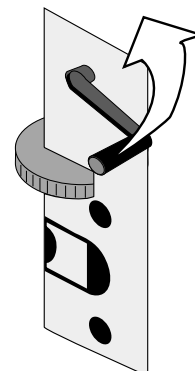

## 5.0 Operations

In this section you will find information on how to properly turn your Falcon 60 H Laminator on, learn functions of the control panel, increase and decrease temperature, properly load and unload film, use of the unwind brake tensioning system, rewind brake tensioning, how to manually set the nip for mounting, and foot switch function.

The following general rules should always be adhered while operating this machine.



### WARNING

Do not wear ties, loose fit clothing or dangling jewelry while operating or servicing the laminator. These items can get caught in the nip and choke you or you can be crushed or burned.



### INFORMATION

The machine will only operate if all four emergency stops are unlatched and RESET has been pressed.



### WARNING

It is unsafe to sheet feed without the pressure plate properly placed on the front feed table.



### WARNING

When the laminator rollers are in motion, keep hands and fingers away from the nip of the rollers. You may be CRUSHED or BURNED!



### WARNING

Keep hands and fingers clear of the laminator roller nip when changing GAP. You can be CRUSHED or BURNED!



### WARNING

When operating the laminator using the footswitch, keep hands and fingers away from the nip of the rollers. You may be CRUSHED or BURNED!



### WARNING

Do not operate the laminator, except during web set up, without the front and rear feed tables in position.

# 5.1 Power On/ Off

d) Power indicator on the control panel should be illuminated at this time.

## Power on

a) Ensure the laminator is plugged in and that all **E-STOPs** are in the unlatched position.

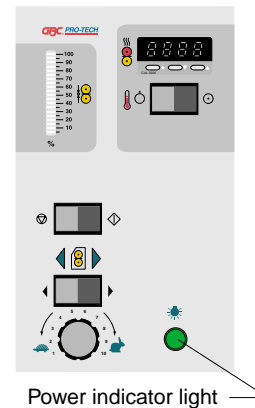
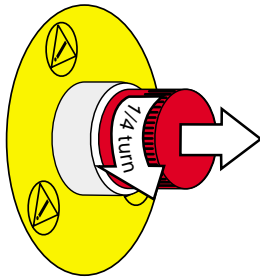

## Power off

b) Turn the **MAIN POWER** to the up position.

a) Ensure the rollers are in the up position.

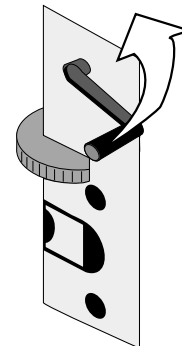
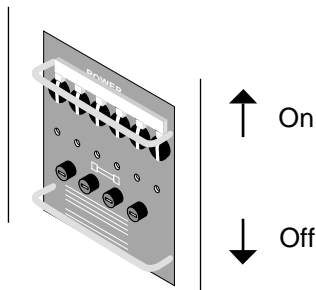

c) Press **RESET** located above the main power on/off.

b) Turn the **MAIN POWER** to the down position.

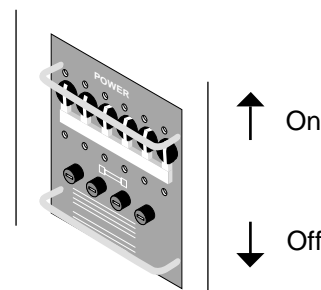
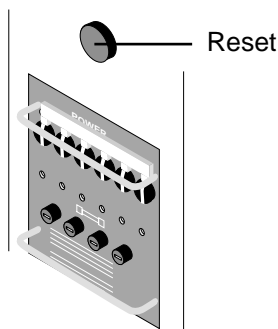

## 5.2 Control panel

The operator control panel for the Falcon 60 H Laminator is located to the right of the front operating position. For an illustration of the complete front control panel, please refer to **Figure 5.2.1 Falcon 60 H**. The names and functions of these controls are as follows:

**( 1 ) NIP PRESSURE DISPLAY:** When pressure at the nip of the rollers is applied, bars on the nip pressure display are illuminated in increments of 5% up to 100%.

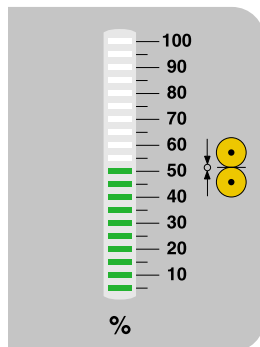

**( 2 ) MOTOR ENGAGE/ DISENGAGE:** When pressed to the right, power to the motor is supplied and the rollers will begin to turn. When pressed to the left, power to the motor is removed and the rollers stop turning.



**( 3 ) FWD/ REV:** When pressed to the right, the motor turns in a forward direction as illustrated by the image above the switch. When pressed to the left, the motor turns in a reverse direction.

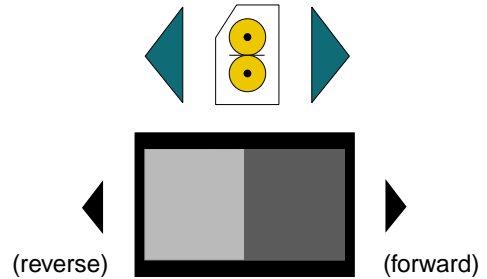

**( 4 ) SPEED DIAL:** When turned clockwise, increases the speed of the motor. Turning it counter clockwise will decrease motor speed.

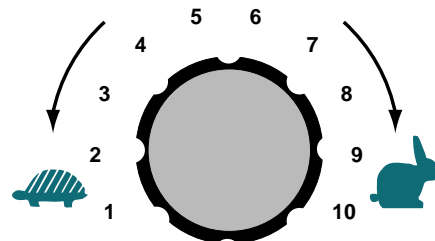

**( 5 ) TEMP ON/ OFF:** When pressed to the right, supplies power to the temperature controller unit located just above it. When pressed to the left, removes power to the temperature controller unit.



( 6 ) **TEMPERATURE CONTROLLER UNIT :**  
 Displays the current temperature of the upper roller. Allows the operator to control the operating temperature of the upper roller. To set temperature refer to **Section 5.3.**

( 7 ) **POWER INDICATOR:** When illuminated represents power to the laminator is supplied. If not illuminated, power to the laminator has been removed via an E-STOP, no RESET, circuit breaker is the off position or line voltage has been removed.



Figure 5.2.1 Front control panel

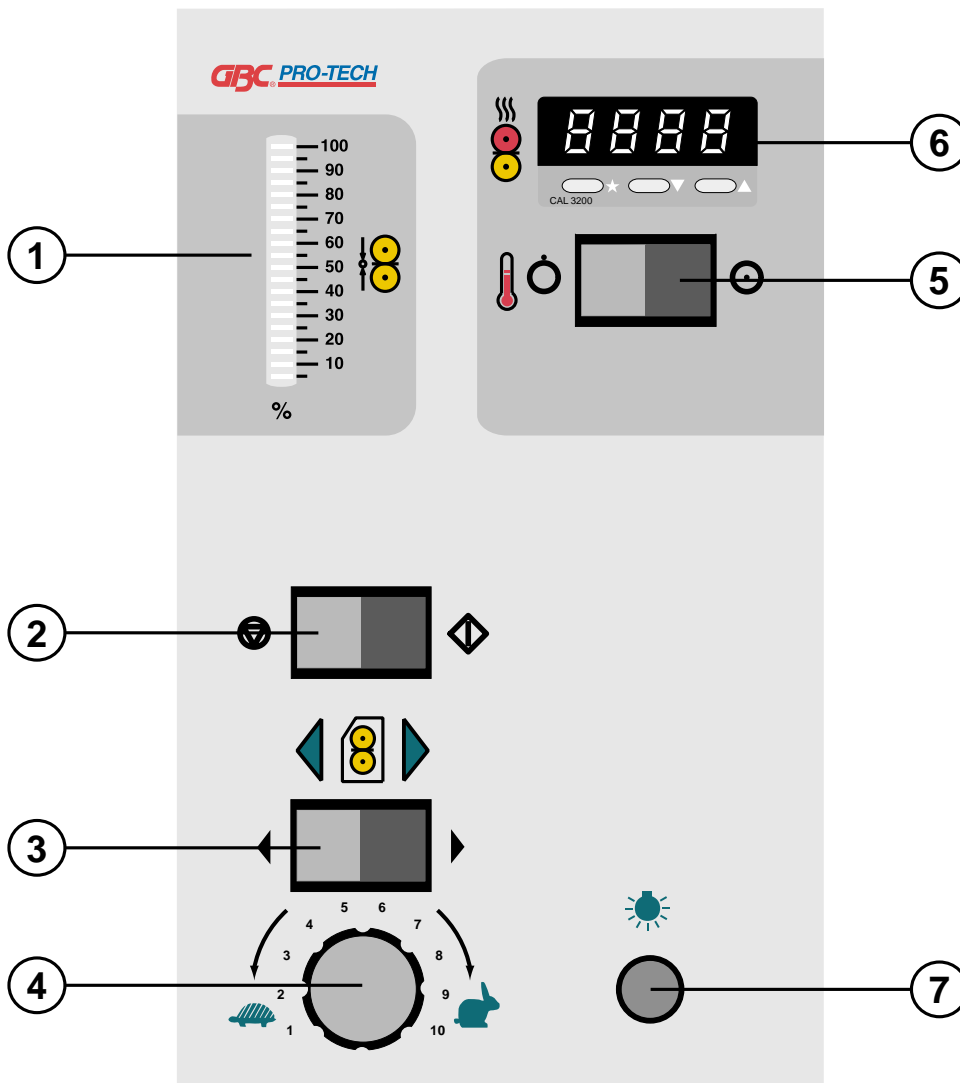

## 5.3 Set Temperature

The Falcon 60 H has upper roller heating capabilities which enables the machine to run Lo-Melt film. You can set a desired temperature from 32 °F ( 0 °C ) up to 200 °F ( 93 °C ).

When power to the temperature controller unit is supplied, the display indicates the current temperature of the upper roller.

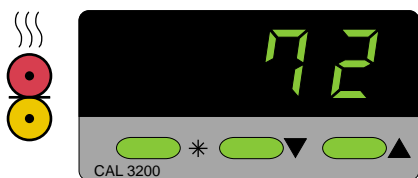

(72 is an example of room temperature )

To display the current set point value of the temperature controller unit, press and hold the star key located just to the left just below the temperature display. When the star key is released, the temperature display reverts to the current temperature of the upper roller.

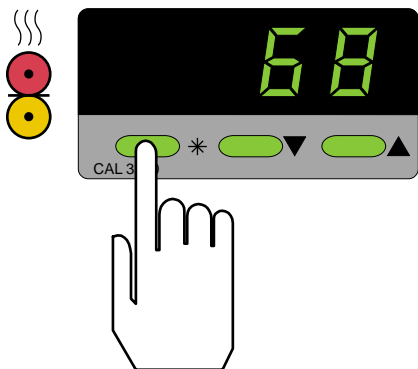

### *Increase set point*

- a) Press and hold \* key while pressing ▲ key to increase the set point temperature. Single presses of the ▲ key increases the set point by increments of one while holding the key down will increase by increments of ones then tens.

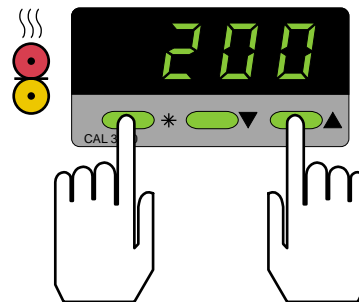

- b) Release the \* key and ▲ key once desired set point has been obtained.

### *Decrease set point*

- a) Press and hold \* key while pressing ▼ key to decrease the set point temperature. The same increments apply.

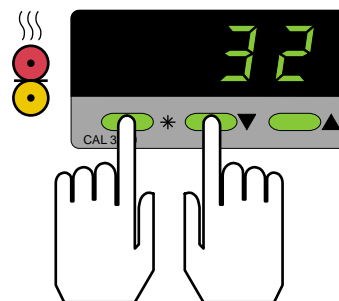

- b) Release the \* key and ▼ key once desired set point has been obtained.

# 5.4 Load/ Unload film



**CAUTION**

Ensure the roll of laminate is loaded properly on the unwind shaft.  
 Exposed adhesive should be facing away from the rollers.  
 This will prevent hours of roll cleaning!



**INFORMATION**

The Poly-in/ Poly-out diagrams refer to the upper rolls of film only. The mount adhesive and craft papers are for reference only.

Figure 5.4.1 Lo-Melt Poly-in/ Poly-out

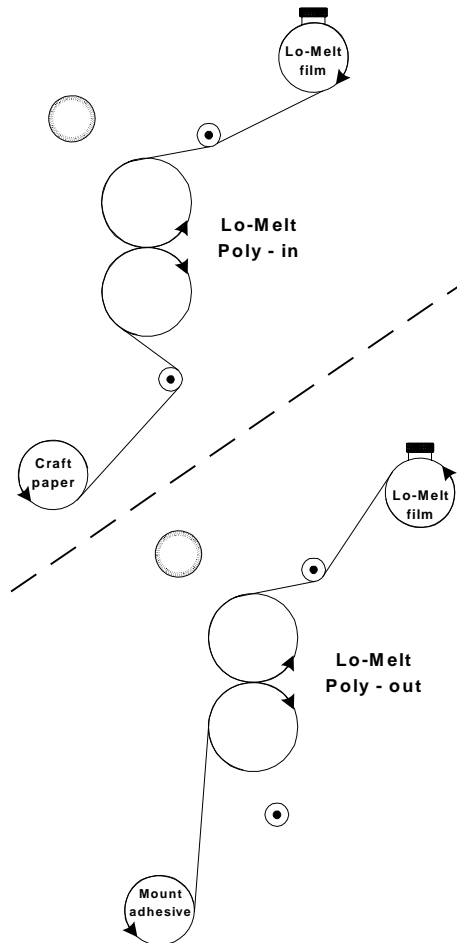
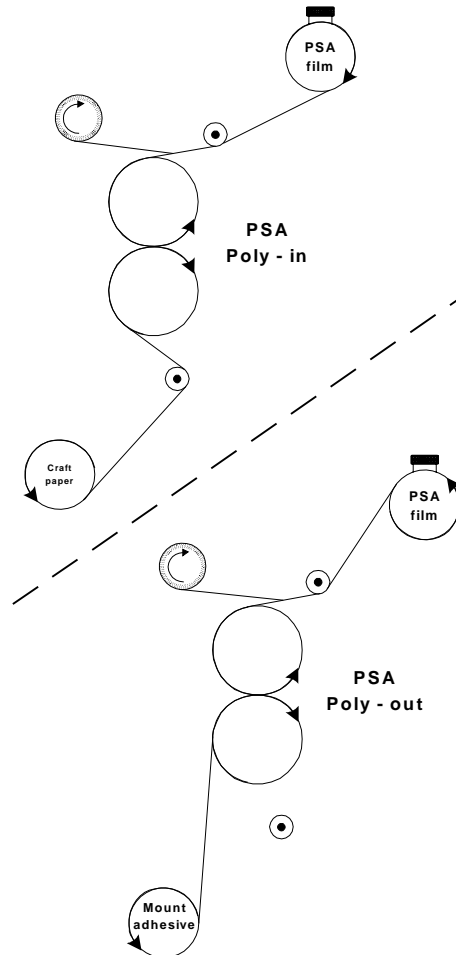
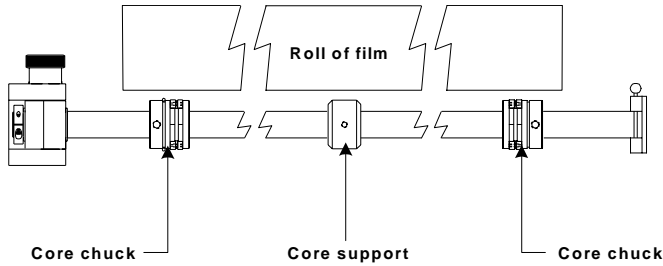

Figure 5.4.2 PSA Poly-in/ Poly-out



# Load film

- a) Adjust the core grips so they are close to the edge of the roll of film being used but remain inside the core when the roll of film is positioned on the unwind shaft.



- b) Lift up on the clevis pin to the unwind shaft located in the unwind support saddle.

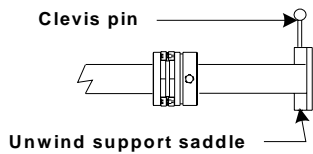

- c) Swing the unwind shaft out far enough to slide the roll of film completely on.

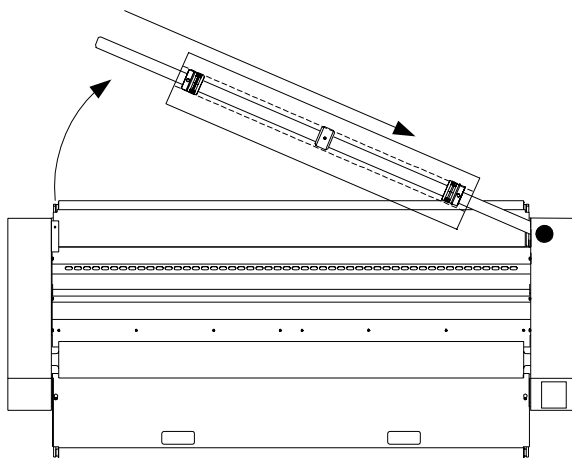

**WARNING**

Never leave the unwind shaft out of the unwind support saddle unless loading or unloading film.

- d) Swing the unwind shaft completely back into the unwind support saddle and push the clevis pin down.

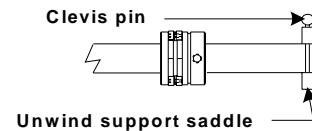

- e) If using the lower unwind, center the upper roll of film on the laminating rollers.

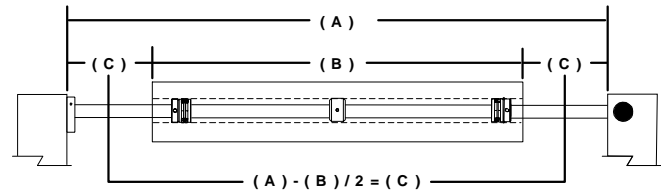

**CAUTION**

When using two rolls on the machine, ensure the film widths are identical. Exposed adhesive can cause complications.

- f) Repeat steps a) through c) to load film on the lower unwind shaft.

- g) Measure the distance from the side frame to the edge of the upper roll of film. Use this measurement to evenly align the roll of mount adhesive or craft paper.

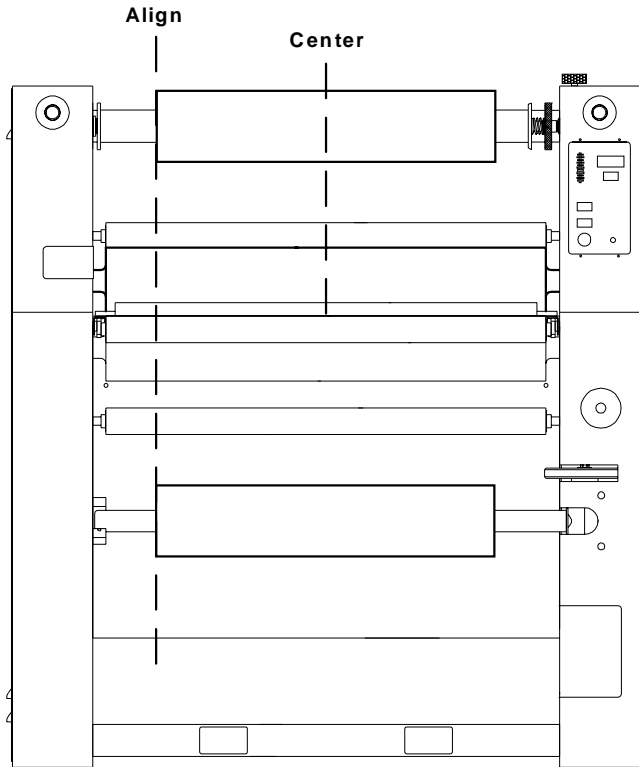

- b) Lift up on the clevis pin to the unwind shaft located in the unwind support saddle.

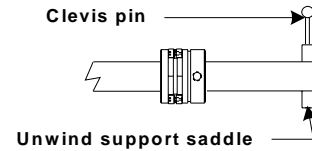

- c) Swing the unwind shaft out far enough to slide the roll of film completely off.

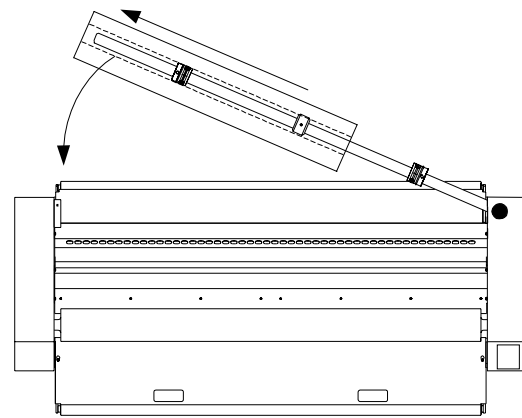

*Unload film*

- a) Cut the roll of film from the web using an enclosed blade.



**CAUTION**

When using two rolls on the machine, ensure the film widths are identical. Exposed adhesive can cause complications.



**CAUTION**

Never use an open blade near the laminating rollers. You may cut the rollers or your self.

- d) Swing the unwind shaft completely back into the unwind support saddle and push the clevis pin down.

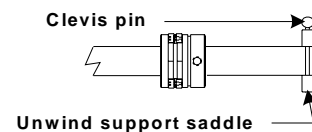

## 5.5 Unwind brake tension

The unwind brakes are uniquely designed to allow you to change rolls of film without changing your current brake setting. Brake tension may vary from roll to roll so some adjustments may be required for optimal output.



### INFORMATION

Always use the minimum amount of brake for the job.

- a) Turn the upper black brake knob ( shown below ) or the lower gray brake disc ( not shown ) clockwise to increase unwind brake tension.

**Increase**

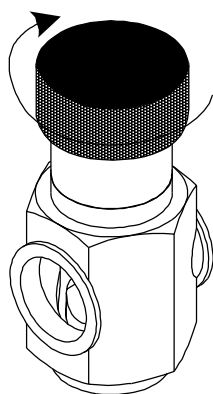

**decrease**

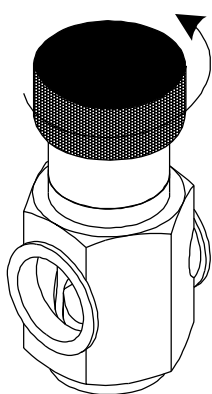

- b) Turn the upper black brake knob ( shown above ) or the lower gray brake disc ( not shown ) counter clockwise to decrease unwind brake tension.

## 5.6 Rewind brake tension

The rewind brake controls the tension of the rewind tubes. Rewind brakes along with the unwind brakes allow for precise control of the release liner in PSA films. If your Falcon 60 H is equipped with the roll to roll option, the rewind brakes are helpful as the finished product rewind becomes heavier by adding more friction to the rewind tube.

- a) Turn the brake dial counter clockwise to increase rewind brake tension.



### INFORMATION

If more brake is needed, add an O-ring to the brake side of the rewind.

**Increase**

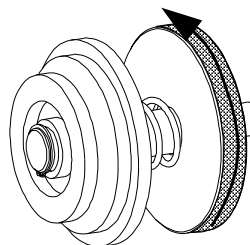

**Decrease**

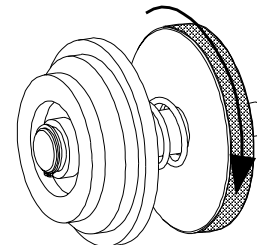

- b) Turn the brake dial clockwise to decrease rewind brake tension.

# 5.7 Setting the nip

Setting the nip is made easy when it comes to performing a mounting application. Pressure will vary with regards to the types of substrate being used. An incorrect nip setting can cause complications with output quality.

For safe nip setting, always adhere to the following rules listed below.

- a) Ensure all E-STOPS are unlatched, power is on and **RESET** has been pressed.

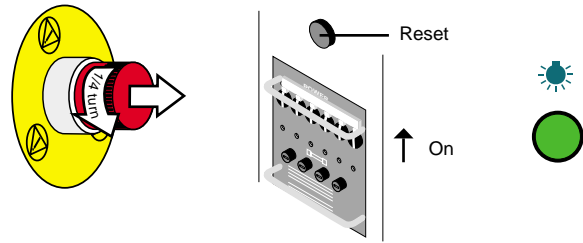

- b) Set the motor direction to **REV**.

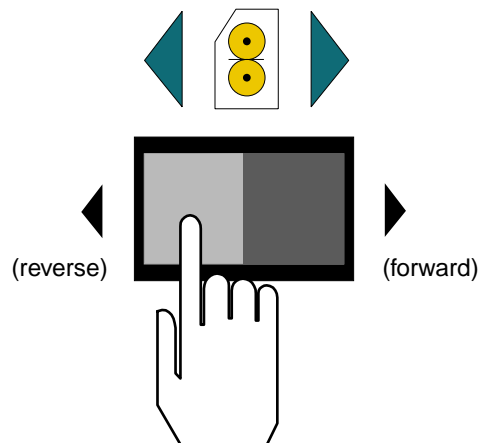

- c) Set a comfortable speed for the application you are performing.

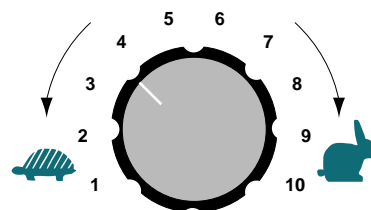

**WARNING**

Keep hands and fingers clear of the laminator roller nip when adjusting nip. You can be **CRUSHED** or **BURNED**!



**CAUTION**

Excess pressure can damage the laminating rollers. Always use the minimum roll pressure necessary to complete the task.



**CAUTION**

Objects other than media, film or approved substrates, will cause irreparable damage to the rollers if caught in the nip.



**CAUTION**

Sharp edges on a substrate should be filed smooth. Sharp edges can CUT the rollers!



**INFORMATION**

Excessive pressure will cause the substrate to bow or flatten.

d) Position the substrate center of the feed table between the two rollers.

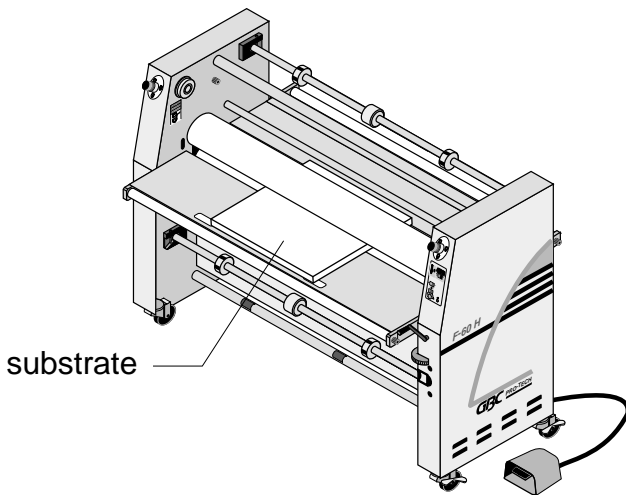
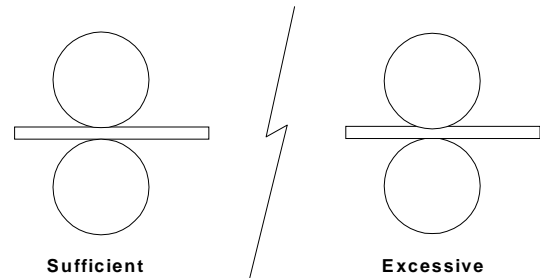

**INFORMATION**

Density of the substrate will determine the amount of pressure you may use.

e) Lower the upper main roller until it makes contact with the substrate. Lower enough to apply sufficient pressure without crushing the substrate.

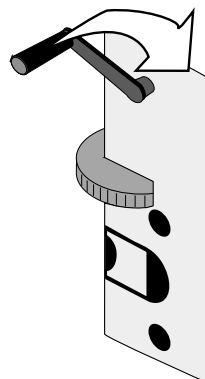

f) Press the motor engage/ disengage to **engage** or step on the footswitch to back the board out from the nip.

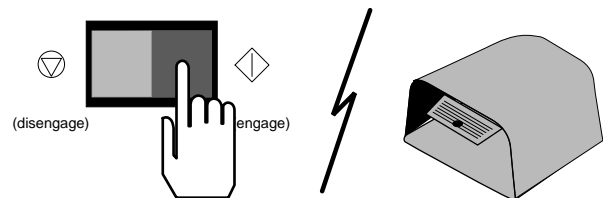

f) The nip is now set for the substrate being used. Remember to set the motor direction to **FWD**.

# 5.8 Footswitch



**WARNING**

When operating the laminator using the footswitch, keep hands and fingers away from the nip of the rollers. You may be **CRUSHED** or **BURNED**!

The footswitch operates differently based on the motor direction setting.

## *Forward*

a) Press the motor direction to **FWD**.

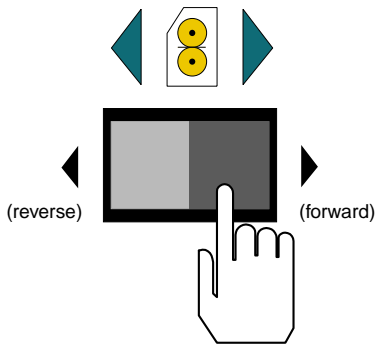

b) Set your speed dial to a comfortable operating speed.

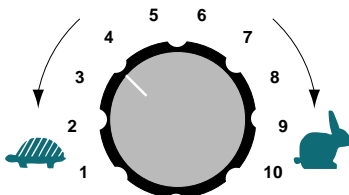

**WARNING**

The variable speed footswitch over-rides the **PHOTO-EYE** safety circuit !

c) When the footswitch is pressed, roller speed is dependent on what you have selected on the speed dial.

d) You may adjust speed while the footswitch is depressed.

## *Reverse*

a) Press the motor direction to **REV**.

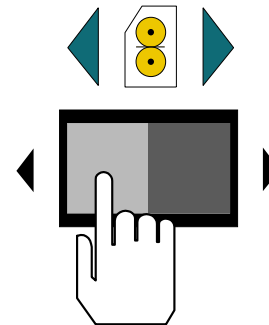

b) Press on the footswitch. The footswitch speed is limited to 1 foot per minute ( 30 cm/ minute ) regardless of motor speed dial setting..



## Mounting

Mounting on the Falcon 60 H is achieved from the front operating position. Heat can also assist with mounting, it follows the same hints as pressure sensitive materials.



## INFORMATION

The mount adhesive must not exceed 1 in. the width of the substrate. If it does, you will experience complications with this application.

## Brake tension

Brake tension should always be minimal. Brake tension should always be even from the top roll of film to the lower roll of film. Never use excessive amount of brake tension.



## INFORMATION

Excessive brake tension may cause the image to curl. Always use the minimum amount of brake for the job.

## Pressure

Most lamination is performed at 50 ~ 70% of pressure on the rollers. Once again, there are variables that may require some adjustments of the above mentioned pressures.

Typically the thicker the paper, the more pressure required and for thinner paper ( tissue paper/ light bond paper ) you can use less pressure ( as little as 50 % ) on the roller.

When it comes to mounting, the one general "rule" is to not crush the substrate. Most substrates only require about 20-50 % of pressure, but variables can effect how much pressure is actually needed. ( width, thickness, density, etc. )

## General



## CAUTION

Excess pressure can damage the laminating rollers. Always use the minimum roll pressure necessary to complete the task.



## INFORMATION

Never stop the laminator when an image is within the nip of the rollers.



## INFORMATION

Excessive pressure will cause the substrate to bow or flatten.



## INFORMATION

Laminates and papers should always be stored in a controlled environment.

## 6.2 Temp conversion chart

A temperature conversion chart has been included for your convenience. Use the chart below for converting temperatures from °F to °C and vice versa.

Figure 6.2.1 Temperature conversion chart

|     |   |      |     |   |      |     |   |      |     |   |      |
|-----|---|------|-----|---|------|-----|---|------|-----|---|------|
| ° F | = | ° C  | ° F | = | ° C  | ° F | = | ° C  | ° F | = | ° C  |
| 68  | = | 20   | 102 | = | 38.9 | 136 | = | 57.8 | 170 | = | 76.7 |
| 69  | = | 20.6 | 103 | = | 39.4 | 137 | = | 58.3 | 171 | = | 77.2 |
| 70  | = | 21.1 | 104 | = | 40   | 138 | = | 58.9 | 172 | = | 77.8 |
| 71  | = | 21.7 | 105 | = | 40.6 | 139 | = | 59.4 | 173 | = | 78.3 |
| 72  | = | 22.2 | 106 | = | 41.1 | 140 | = | 60   | 174 | = | 78.9 |
| 73  | = | 22.7 | 107 | = | 41.7 | 141 | = | 60.6 | 175 | = | 79.4 |
| 74  | = | 23.3 | 108 | = | 42.2 | 142 | = | 61.1 | 176 | = | 80   |
| 75  | = | 23.9 | 109 | = | 42.8 | 143 | = | 61.7 | 177 | = | 80.6 |
| 76  | = | 24.4 | 110 | = | 43.3 | 144 | = | 62.2 | 178 | = | 81.1 |
| 77  | = | 25   | 111 | = | 43.9 | 145 | = | 62.8 | 179 | = | 81.7 |
| 78  | = | 25.6 | 112 | = | 44.4 | 146 | = | 63.3 | 180 | = | 82.2 |
| 79  | = | 26.1 | 113 | = | 45   | 147 | = | 63.9 | 181 | = | 82.8 |
| 80  | = | 26.7 | 114 | = | 45.6 | 148 | = | 64.4 | 182 | = | 83.3 |
| 81  | = | 27.2 | 115 | = | 46.1 | 149 | = | 65   | 183 | = | 83.9 |
| 82  | = | 27.8 | 116 | = | 46.7 | 150 | = | 65.6 | 184 | = | 84.4 |
| 83  | = | 28.3 | 117 | = | 47.2 | 151 | = | 66.1 | 185 | = | 85   |
| 84  | = | 28.9 | 118 | = | 47.8 | 152 | = | 66.7 | 186 | = | 85.6 |
| 85  | = | 29.4 | 119 | = | 48.3 | 153 | = | 67.2 | 187 | = | 86.1 |
| 86  | = | 30   | 120 | = | 48.9 | 154 | = | 67.8 | 188 | = | 86.7 |
| 87  | = | 30.6 | 121 | = | 49.4 | 155 | = | 68.3 | 189 | = | 87.2 |
| 88  | = | 31.1 | 122 | = | 50   | 156 | = | 68.9 | 190 | = | 87.8 |
| 89  | = | 31.7 | 123 | = | 50.6 | 157 | = | 69.4 | 191 | = | 88.3 |
| 90  | = | 32.2 | 124 | = | 51.1 | 158 | = | 70   | 192 | = | 88.9 |
| 91  | = | 32.8 | 125 | = | 51.7 | 159 | = | 70.6 | 193 | = | 89.4 |
| 92  | = | 33.3 | 126 | = | 52.2 | 160 | = | 71.1 | 194 | = | 90   |
| 93  | = | 33.9 | 127 | = | 52.8 | 161 | = | 71.7 | 195 | = | 90.6 |
| 94  | = | 34.4 | 128 | = | 53.3 | 162 | = | 72.2 | 196 | = | 91.1 |
| 95  | = | 35   | 129 | = | 53.9 | 163 | = | 72.8 | 197 | = | 91.7 |
| 96  | = | 35.6 | 130 | = | 54.4 | 164 | = | 73.3 | 198 | = | 92.2 |
| 97  | = | 36.1 | 131 | = | 55   | 165 | = | 73.9 | 199 | = | 92.8 |
| 98  | = | 36.7 | 132 | = | 55.6 | 166 | = | 74.4 | 200 | = | 93.3 |
| 99  | = | 37.2 | 133 | = | 56.1 | 167 | = | 75   |     |   |      |
| 100 | = | 37.8 | 134 | = | 56.7 | 168 | = | 75.6 |     |   |      |
| 101 | = | 38.3 | 135 | = | 57.2 | 169 | = | 76.1 |     |   |      |

This page intentionally left blank.

## 6.3 Charts and diagrams

Process control charts allow you to record the way you thread film through the machine's rollers and idlers (called webbing) and the control settings for each product and process. Process control charts are an excellent tool for training new operators. They provide a "road map" for correct machine setup and operation.

This section contains a blank process control chart and diagram for the Falcon 60 H as well as completed charts for the basic operations of the laminator. The process control charts should be kept in this manual or in a book close to the laminator.

The Falcon 60 H laminator responds in a very accurate and repeatable manner. The charts provide a way to set up each time, every time for repeatable performance by assuring that all controls are set to optimum.

The completed process control charts included in this section are based on GBC films, GBC boards and typical prints. Charts and diagrams start on page 6-6. If your machine is equipped with the roll to roll option, webbing diagrams for related applications are also included.

PROCESS CONTROL CHART

Materials - \_\_\_\_\_

Top material :

Bottom material :

Other material (s) :

Motor Direction

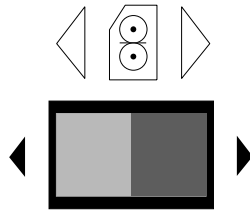

Heater



Motor Speed

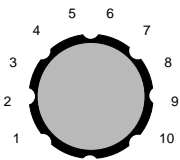

Upper Roller Temperature

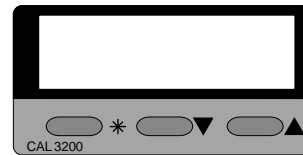

RANGE

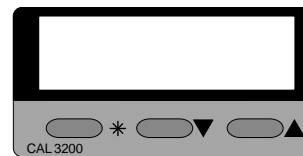

Roller Pressure

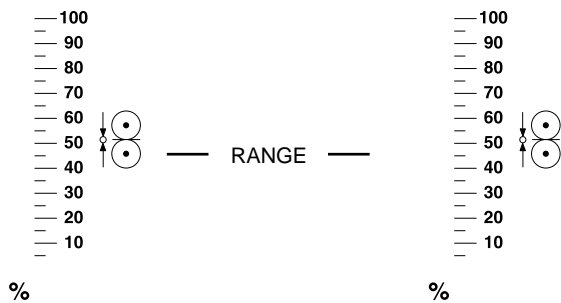

Notes : \_\_\_\_\_  
 \_\_\_\_\_  
 \_\_\_\_\_  
 \_\_\_\_\_  
 \_\_\_\_\_

# Diagram - Blank

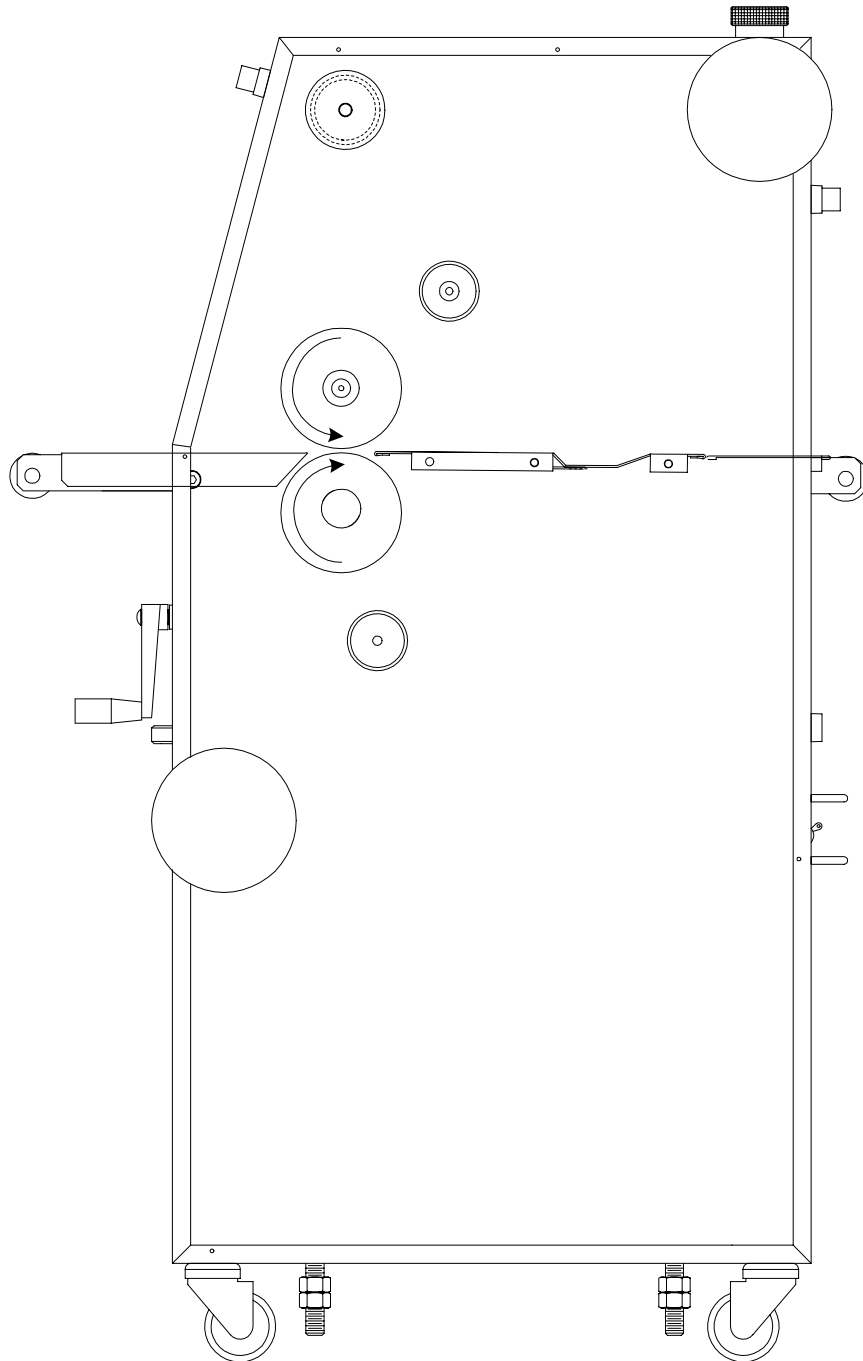

This page intentionally left blank.

# Diagram - Blank w/ roll to roll options

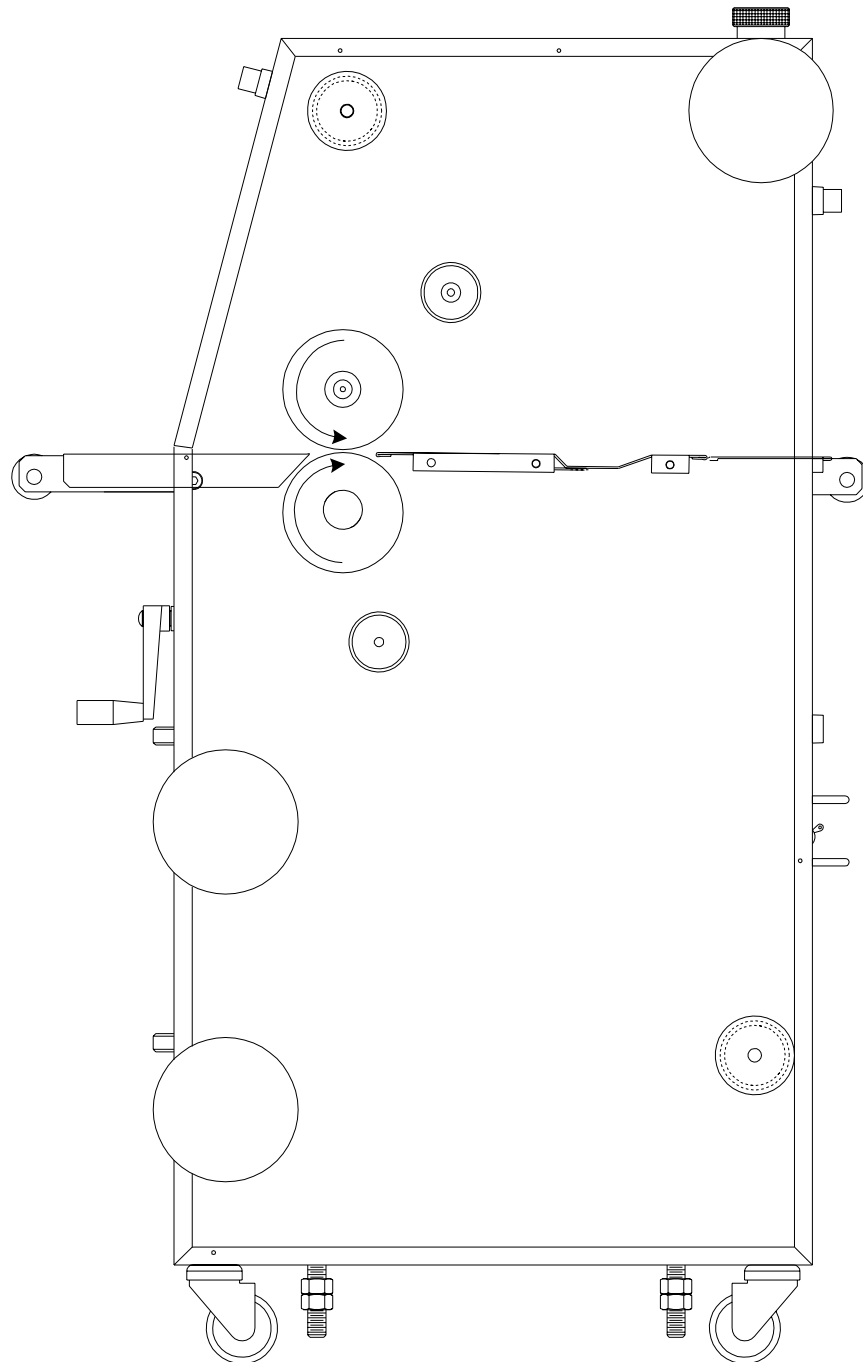

PROCESS CONTROL CHART

Materials - Pre-coating substrates

Top material : Roll of pressure sensitive mount adhesive

Bottom material : N/A

Other material (s) : Substrates, leader board and trailer board

Motor Direction

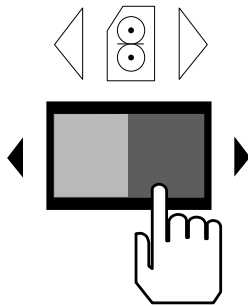

Heater

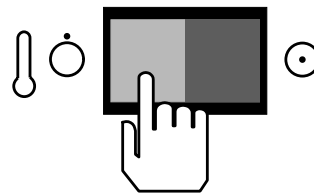

Motor Speed

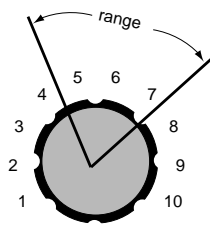

Upper Roller Temperature



RANGE



Roller Pressure

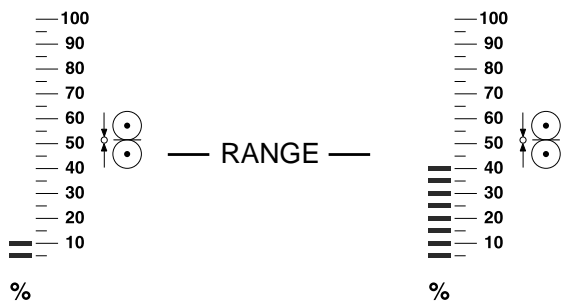

Notes : The roll of mount adhesive should not exceed the substrate by more than 1 in. (2.5 cm). Speed will be determined by what is comfortable with the operator. Pressure is dependent on the substrate. Do not crush the substrate. Use a leader board to start the run and stop the run when the trailer board is in the nip of the rollers. Stopping on a substrate will leave an impression on the board. Refer to helpful hints for pressure sensitive materials and mounting.

# Diagram - Pre-coating substrates

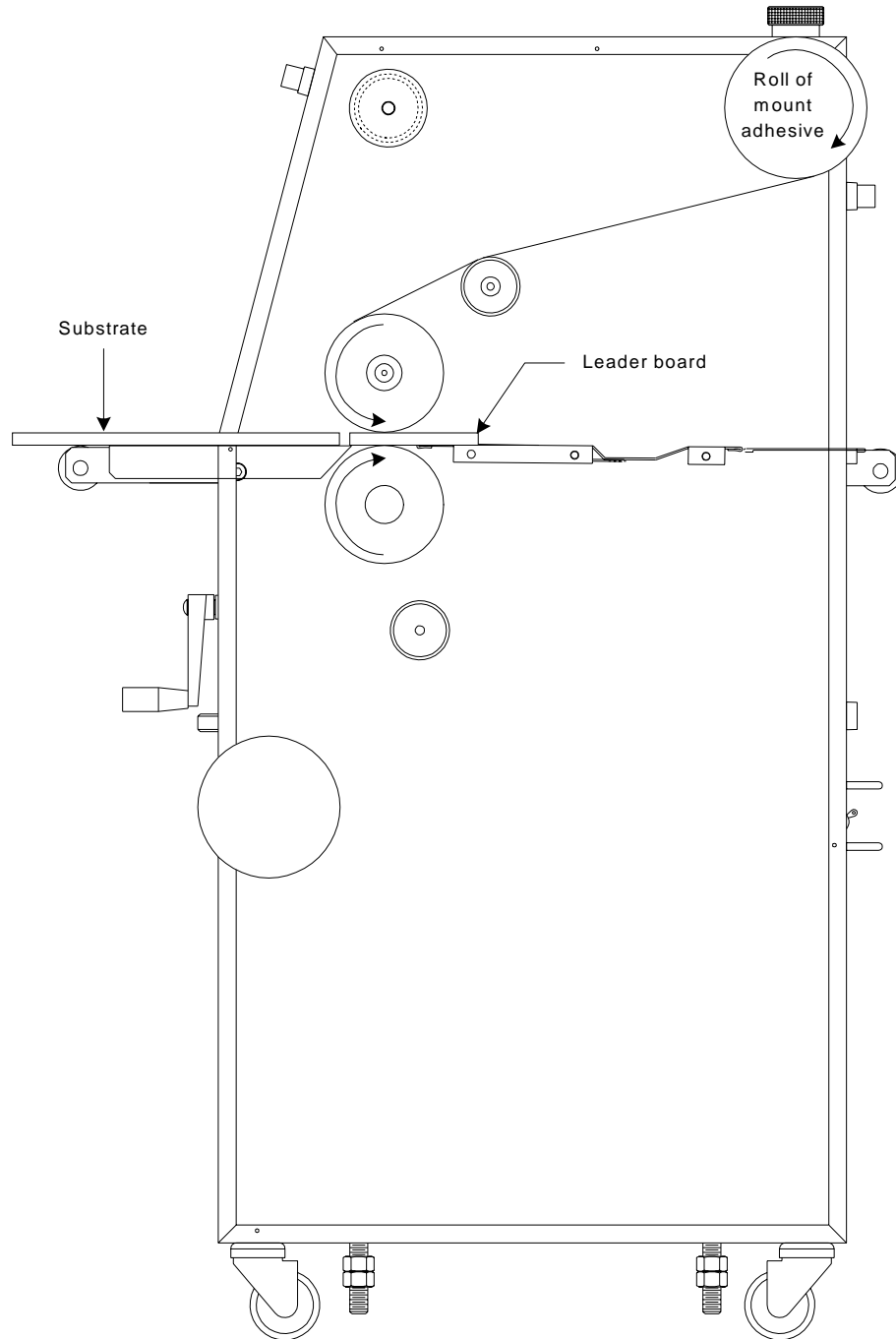

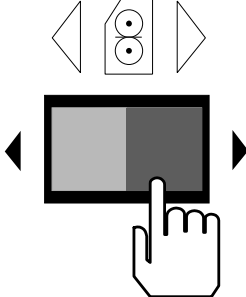
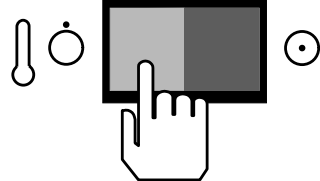
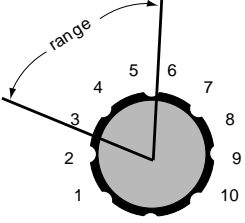
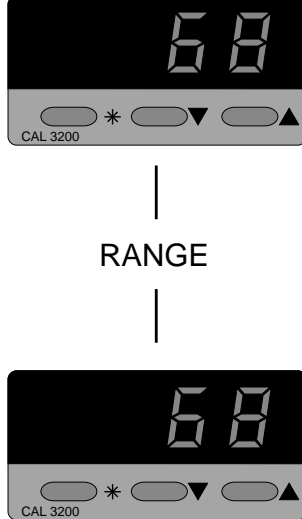
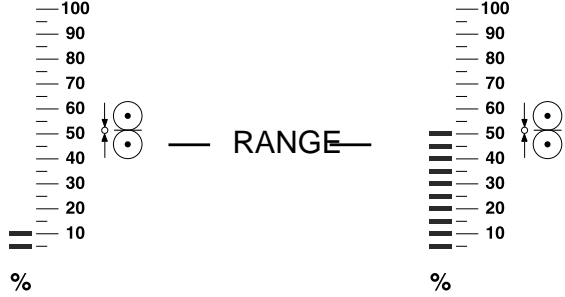
| PROCESS CONTROL CHART   |  |
|---|--|
| Materials - Mounting an image   |  |
| Top material : N/A  |  |
| Bottom material : N/A   |  |
| Other material (s) : Image and a Pre-coated board   |  |
| Motor Direction   | Heater   |
|    |    |
| Motor Speed   | Upper Roller Temperature   |
|    |  |
| Roller Pressure   |  |
|    |  |
| <p>Notes: The image should not exceed the pre-coated board by more than 1 in. ( 2.5 cm ). If the image is smaller than the pre-coated board, trim the board or pre-trim the release liner around the image. Speed for mounting should be comfortable for the operator. Use the footswitch for this application. Pressure will be dependent on the type of substrate. No heat is required for this application. Do not crush the substrate. Do not stop in the middle of the run. Refer to helpful hints for mounting.</p> |  |

# Diagram - Mounting an image

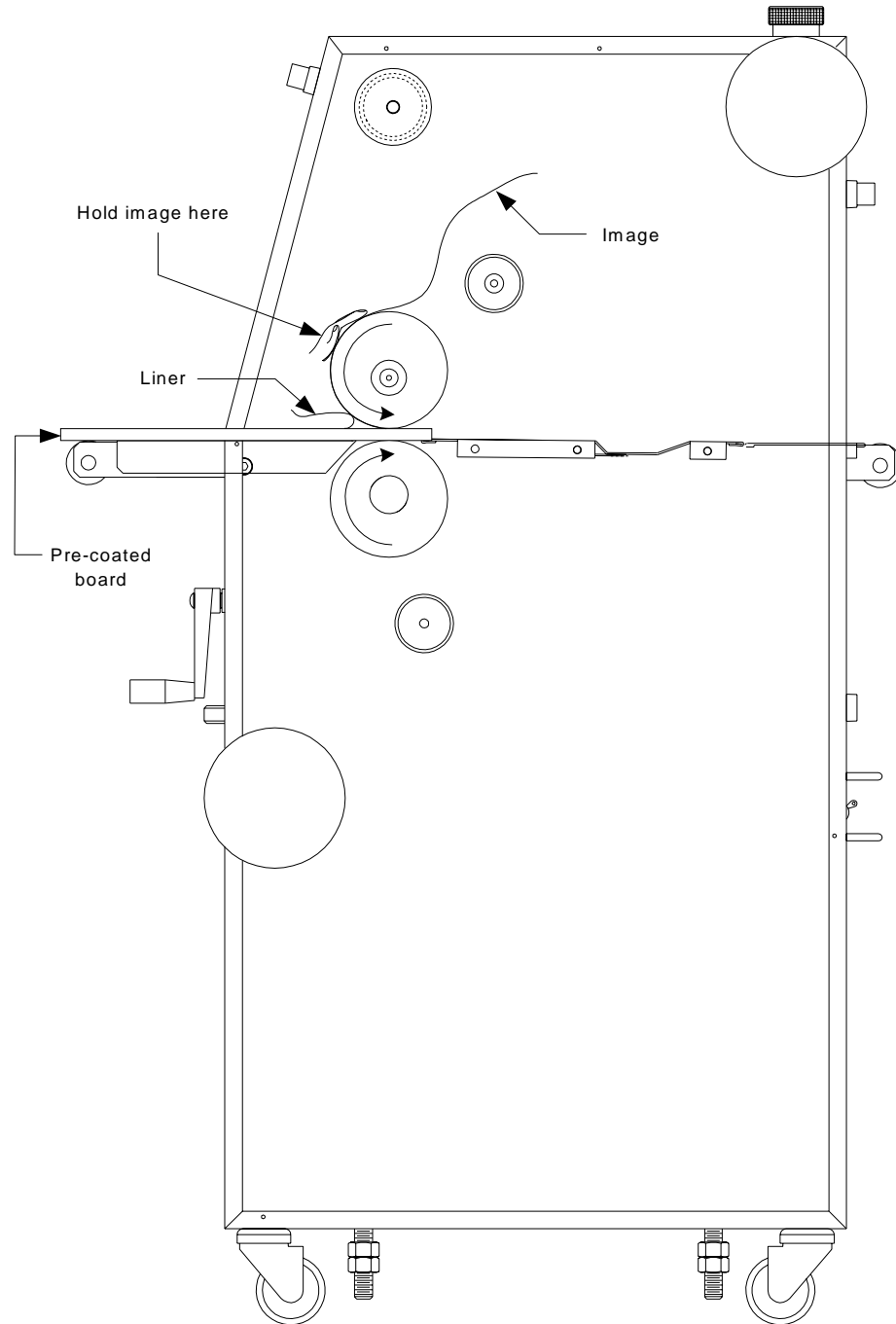

PROCESS CONTROL CHART

Materials - PSA Decaling

Top material : Roll of pressure sensitive laminate

Bottom material : Roll of pressure sensitive mount adhesive

Other material (s) : prints

Motor Direction

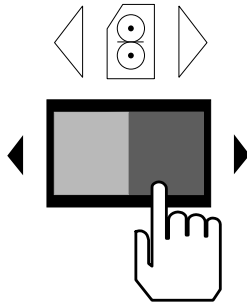

Heater

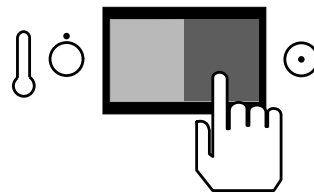

Motor Speed

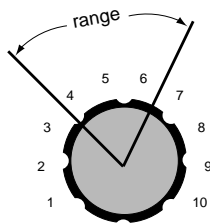

Upper Roller Temperature

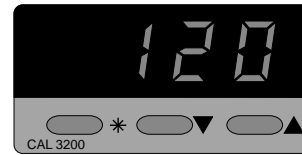

Roller Pressure

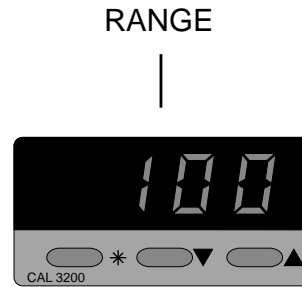
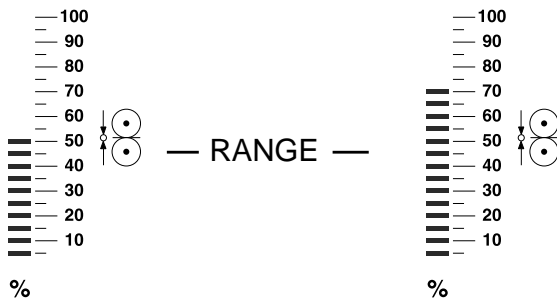

RANGE

Notes: Speed should be comfortable for the operator. Pressure will vary depending on the weight and width of the image and laminate. Heat is optional. Some will assist the flow of the adhesive in pressure sensitive films. Refer to helpful hints for pressure sensitive films.

# Diagram - PSA decaling

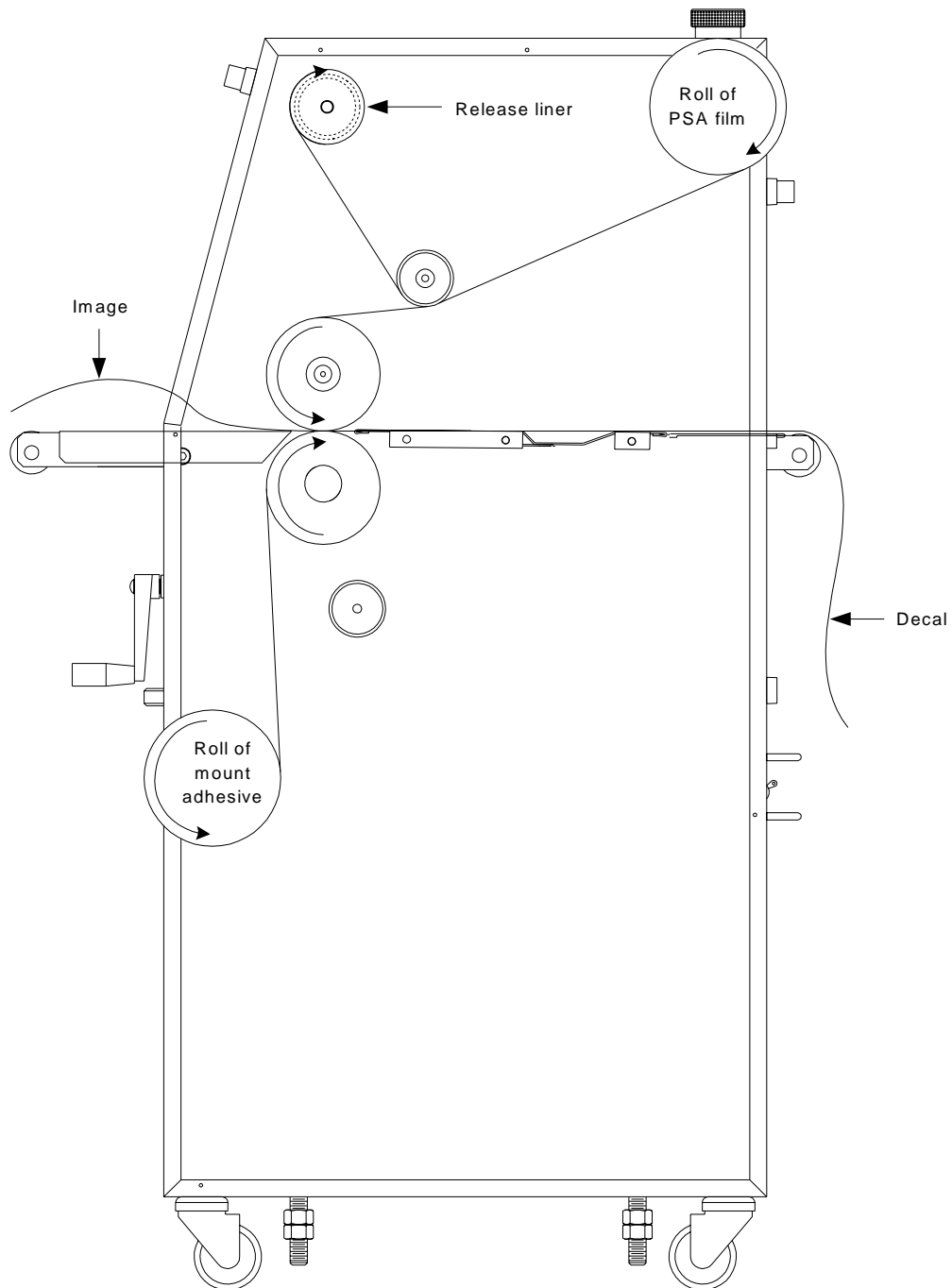

This page intentionally left blank.

# Diagram - PSA decaling w/ roll to roll options

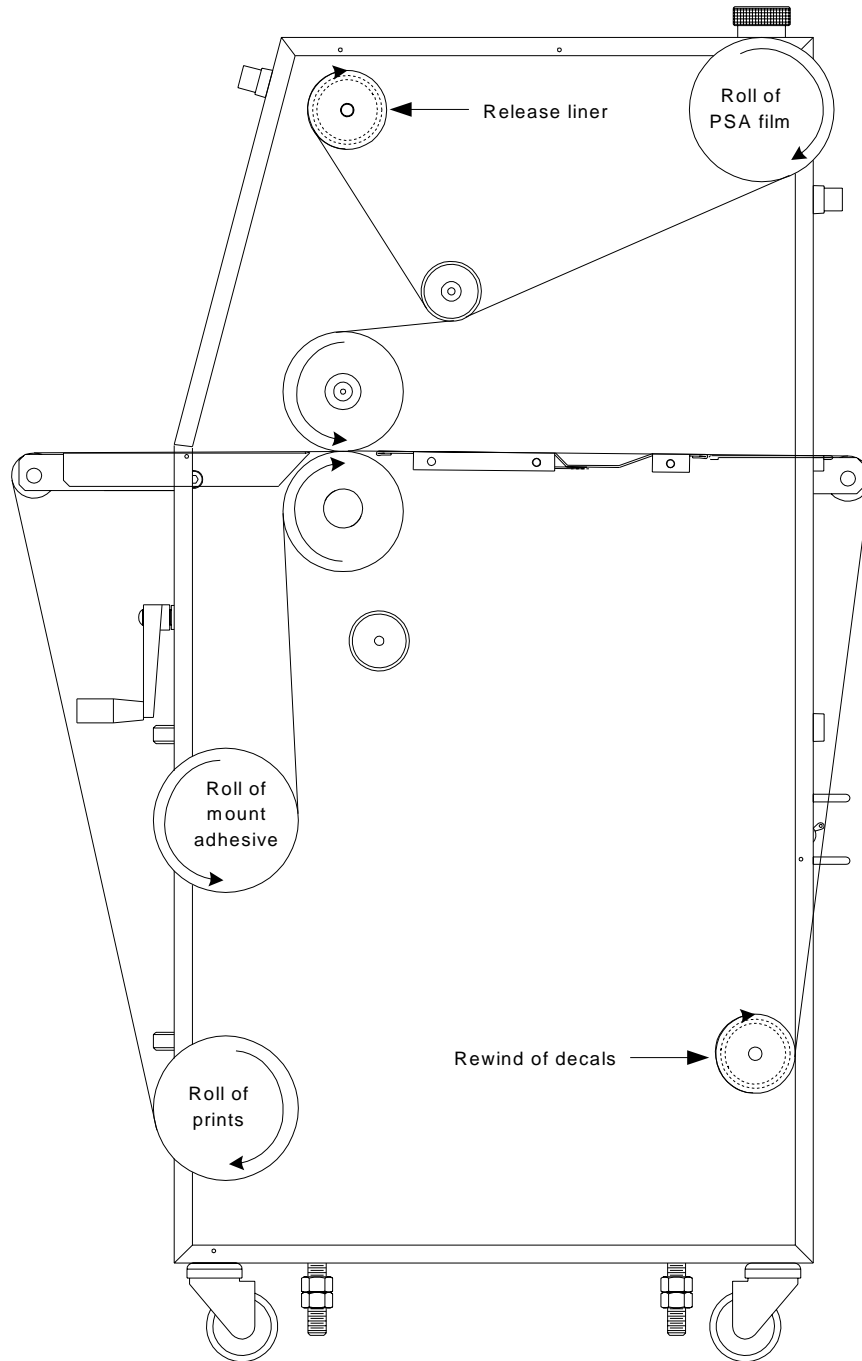

PROCESS CONTROL CHART

Materials - Lo-Melt Decaling

Top material : Roll of Lo-Melt film

Bottom material : Roll of pressure sensitive adhesive

Other material (s) : prints

Motor Direction

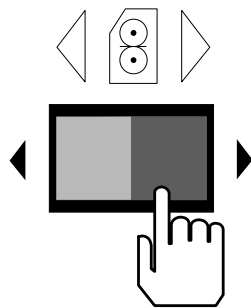

Heater

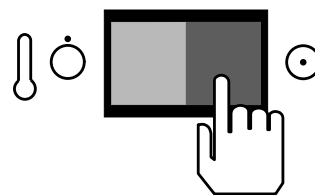

Motor Speed

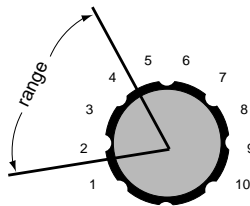

Upper Roller Temperature

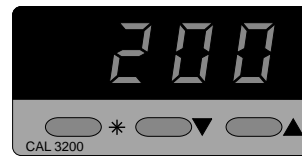

RANGE



Roller Pressure

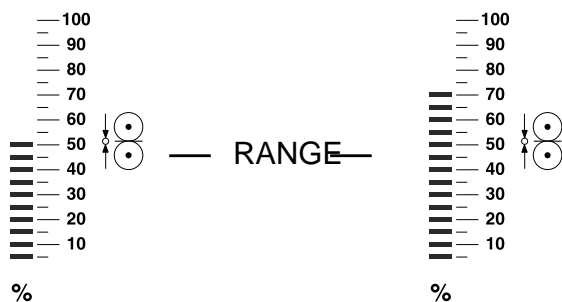

Notes : Speed will be dependent on the activation of the Lo-Melt adhesive. If the output appears cloudy or milky, reduce the speed. Pressure will vary depending on the weight and width of the image and laminate. For thinner laminates, use the 180 °F ( 82 °C ) and for thicker films, use the 200 °F ( 93 °C ).

# Diagram - Lo-Melt decaling

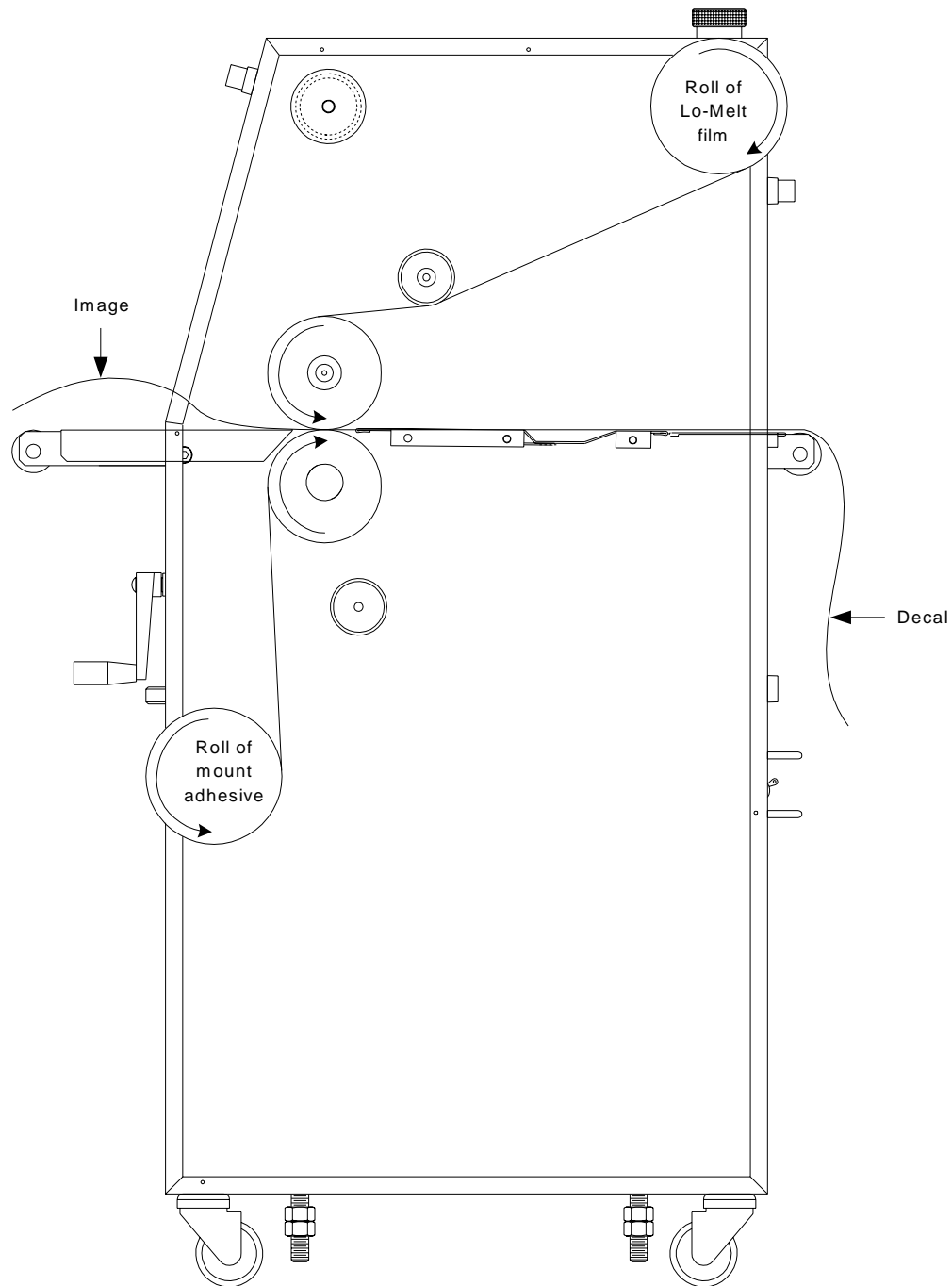

This page intentionally left blank.

# Diagram - Lo-Melt decaling w/ roll to roll options

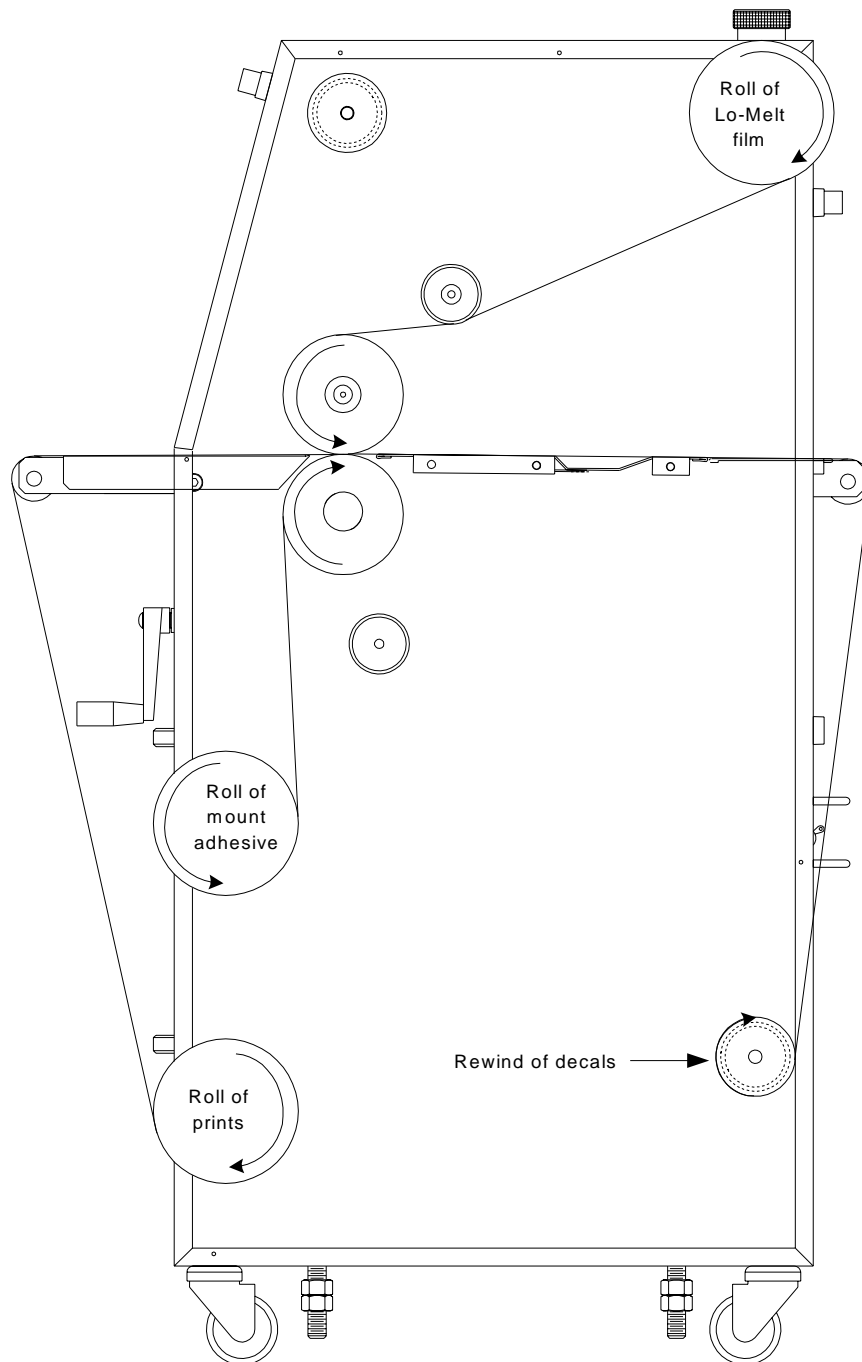

PROCESS CONTROL CHART

Materials - Mounting a decal

Top material : N/A

Bottom material : N/A

Other material (s) : Decal and substrate

Motor Direction

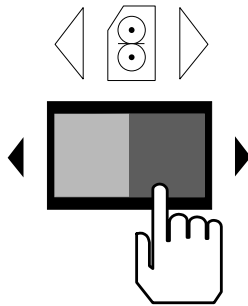

Heater

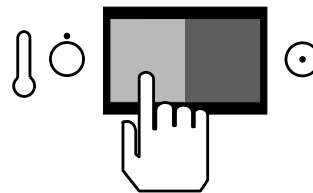

Motor Speed

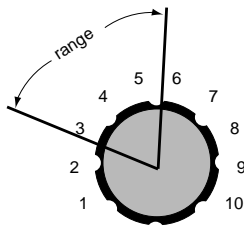

Upper Roller Temperature

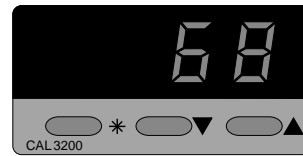

RANGE



Roller Pressure

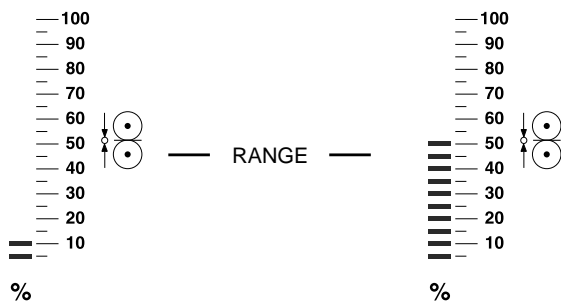

Notes: Speed for mounting should be comfortable for the operator. Use the footswitch for this application. Pressure will be dependent on the type of substrate. No heat is required for this application. Do not crush the substrate. Do not stop in the middle of the run. Refer to helpful hints for mounting.

# Diagram - Mounting a decal

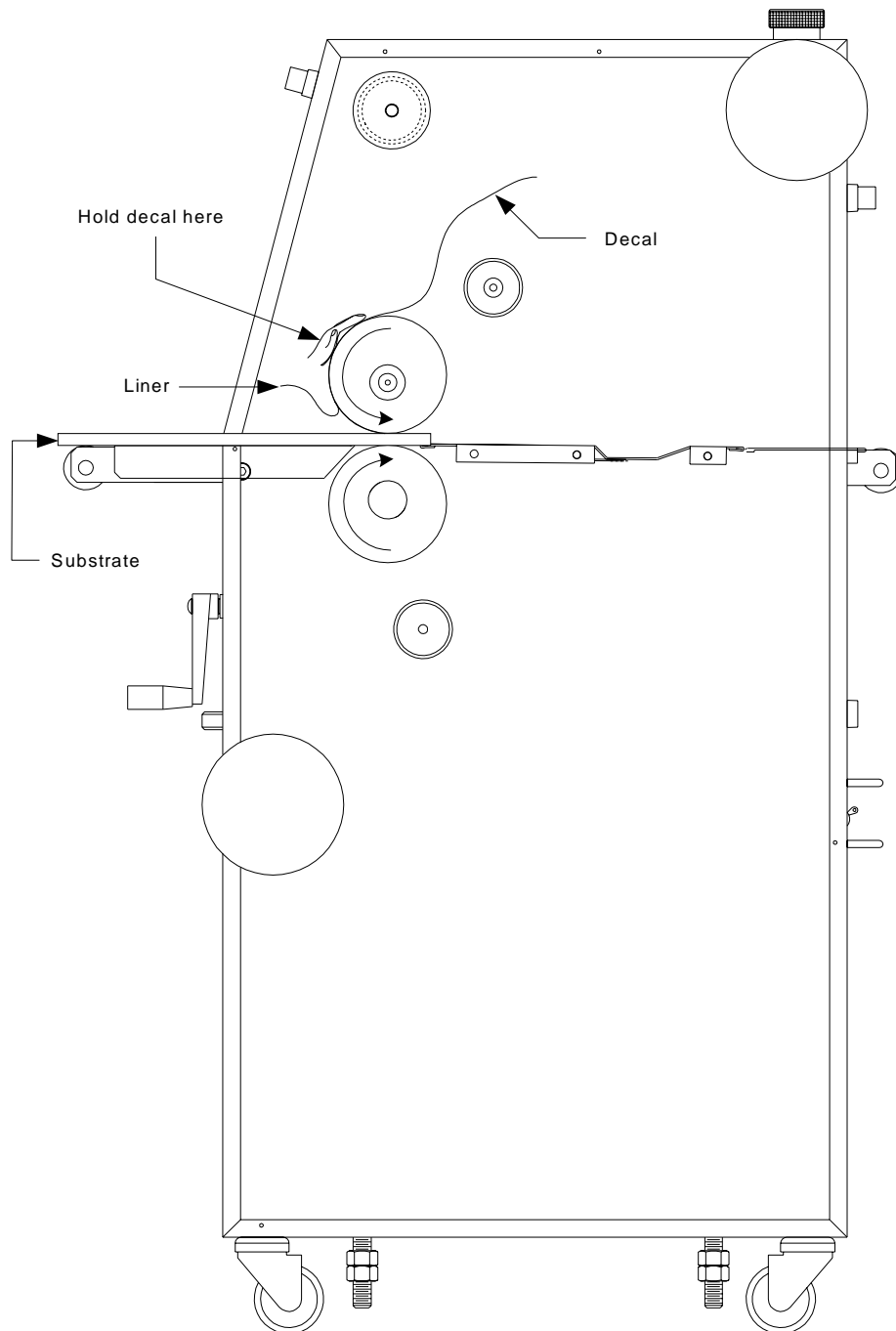

| PROCESS CONTROL CHART   |                          |
|---|--------------------------|
| Materials - PSA Single sided lamination ( sled method)  |                          |
| Top material : Roll of pressure sensitive laminate  |                          |
| Bottom material : N/A   |                          |
| Other material (s) : Images, leader board, trailer board and a pre-coated board   |                          |
| Motor Direction   | Heater                   |
|   |                          |
| Motor Speed   | Upper Roller Temperature |
|   |                          |
| Roller Pressure   |                          |
|   |                          |
| <p>Notes : The leader board and trailer board should be the same width as the pre-coated board. The laminate should not exceed the pre-coated board by more than 1 in. ( 2.54 cm ). Do not use excessive brake tension for this application. Pre-coated board is reusable since the laminate does not bond with the release liner from the pressure sensitive adhesive. Speed should be comfortable for the operator. Pressure will vary depending on the type of substrate. Heat is optional. Some heat will assist the flow of adhesive. Refer to helpful hints for pressure sensitive films.</p> |                          |

# Diagram - PSA single sided lamination ( sled method )

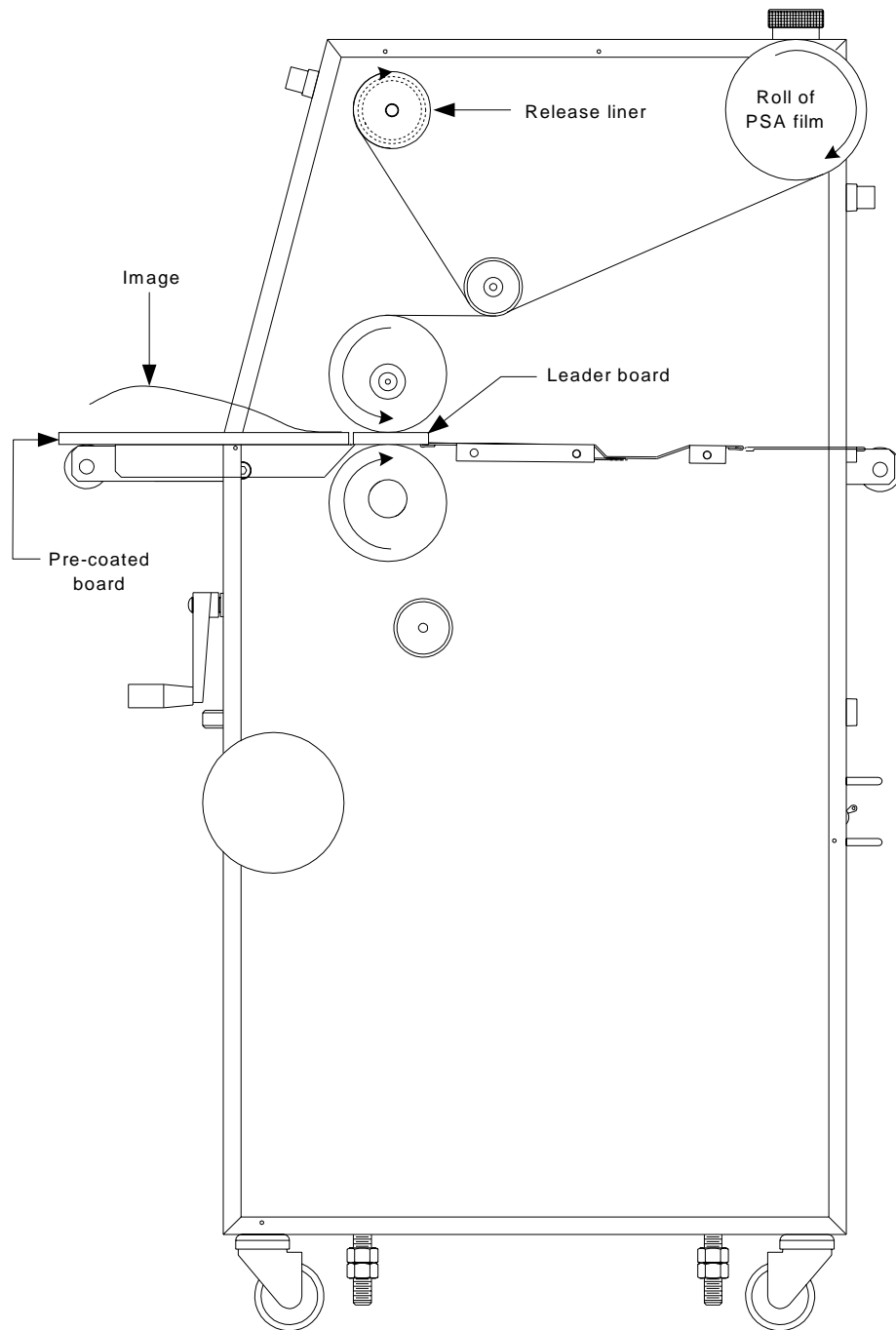

PROCESS CONTROL CHART

Materials - PSA Single sided lamination ( craft paper method)

Top material : Roll of pressure sensitive laminate

Bottom material : Roll of craft paper

Other material (s) : Prints

Motor Direction

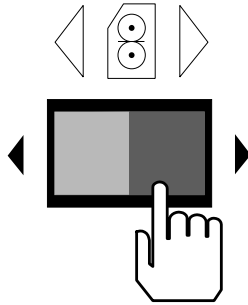

Heater

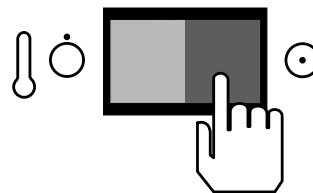

Motor Speed

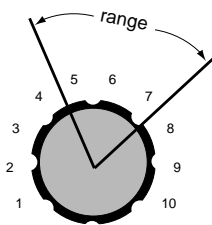

Upper Roller Temperature

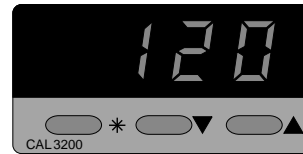

RANGE

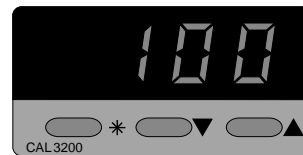

Roller Pressure

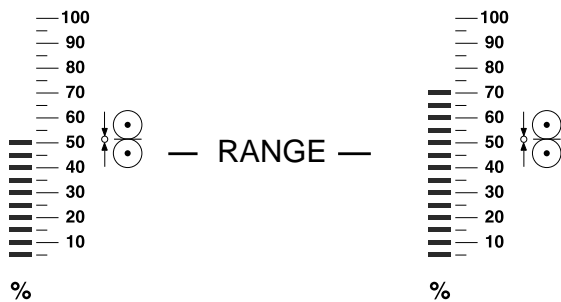

Notes: Top and bottom material should be of the same width. Do not use excessive brake tension for this application. Speed should be comfortable for the operator. Pressure will vary depending on the width and weight of the image and laminate. Heat is optional. Some heat will assist the flow of adhesive. Refer to helpful hints for pressure sensitive films.

# Diagram - PSA single sided lamination ( craft paper method )

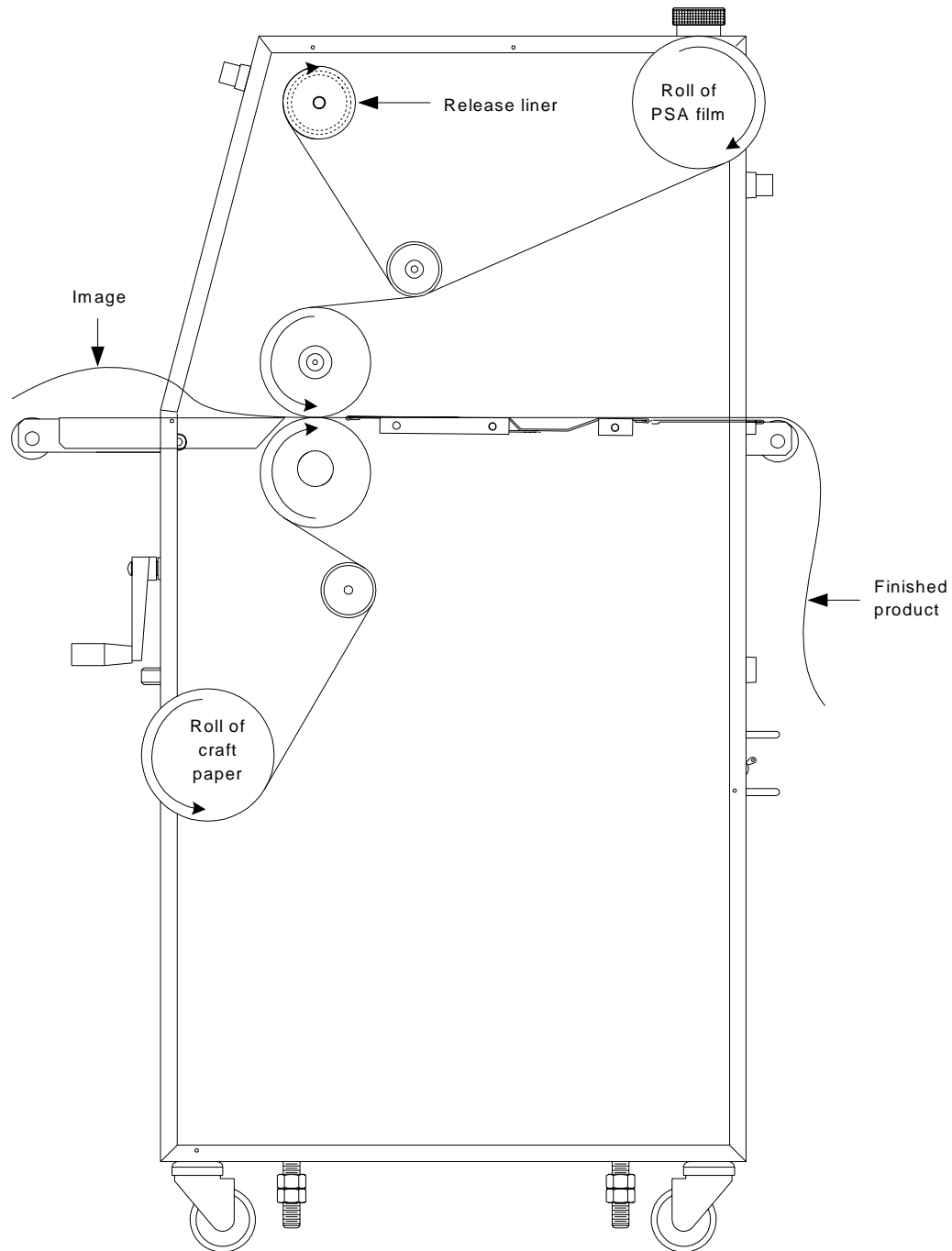



# Diagram - PSA single sided lamination ( craft paper method w/ roll to roll option )

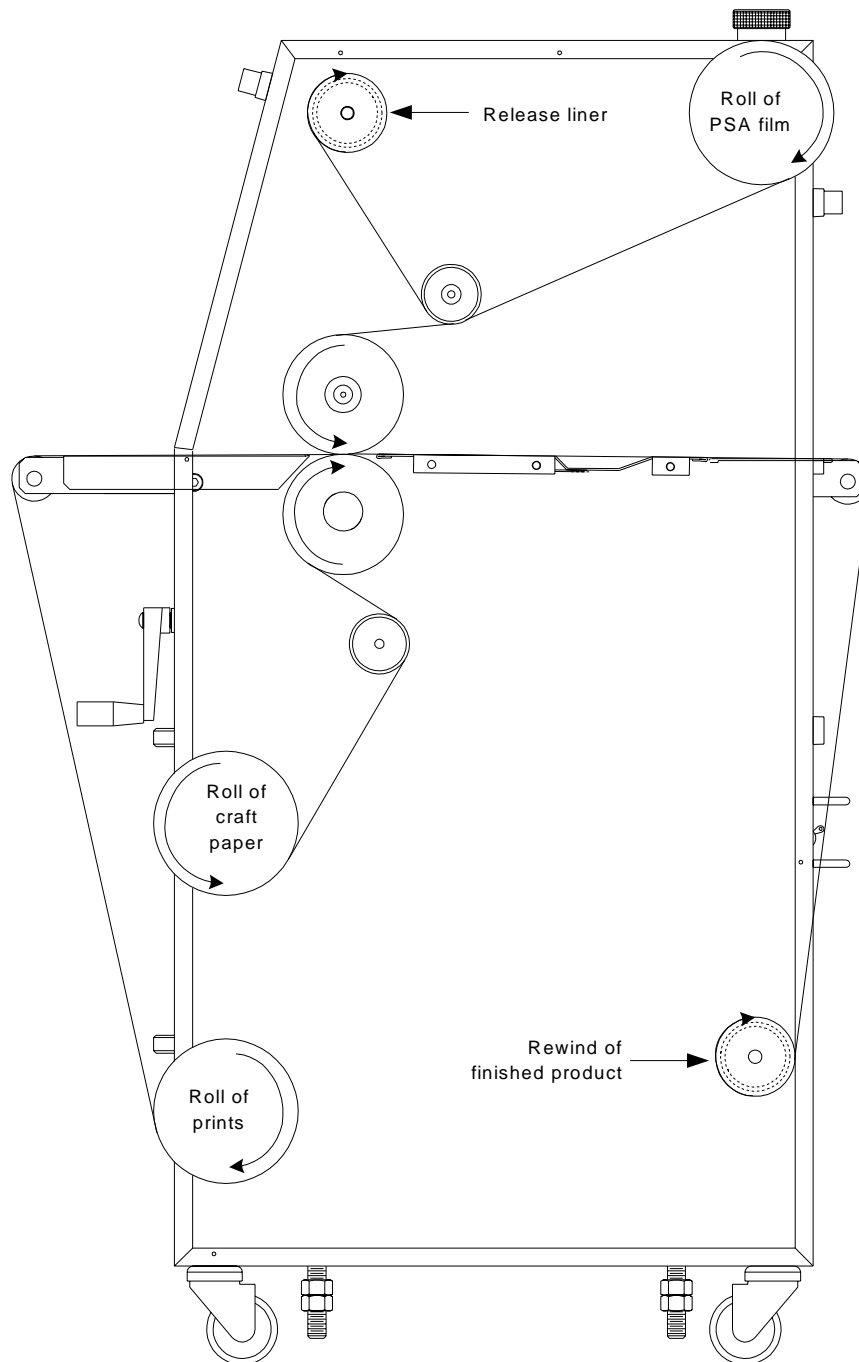

PROCESS CONTROL CHART

Materials - PSA over-lamination of a mounted image

Top material : Roll of pressure sensitive laminate

Bottom material : N/A

Other material (s) : A pre-mounted image to a board, leader board and trailer board

Motor Direction

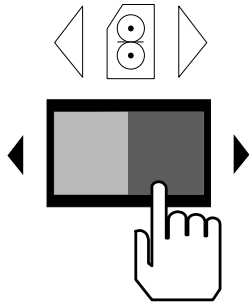

Heater

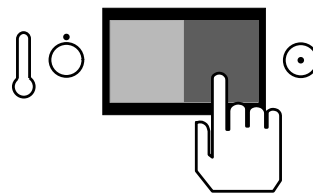

Motor Speed

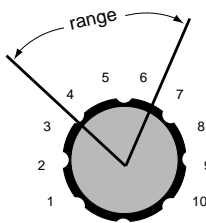

Upper Roller Temperature

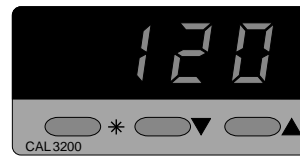

RANGE

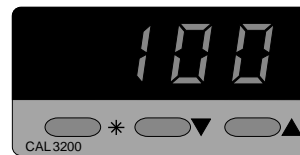

Roller Pressure

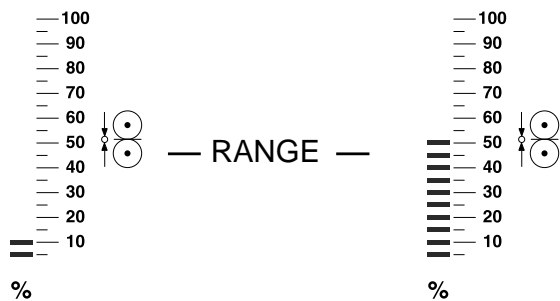

Notes : The laminate should not exceed the pre-mounted image by more than 3 in. (7.6 cm). Speed will be determined by what is comfortable with the operator. Pressure is dependent on the substrate. Do not crush the substrate. Use a leader board to start the process and finish with a trailer board. Stopping on the image will leave an impression on the board or image. Heat is optional. Refer to helpful hints for pressure sensitive materials and mounting.

# Diagram - PSA over-lamination of a mounted image

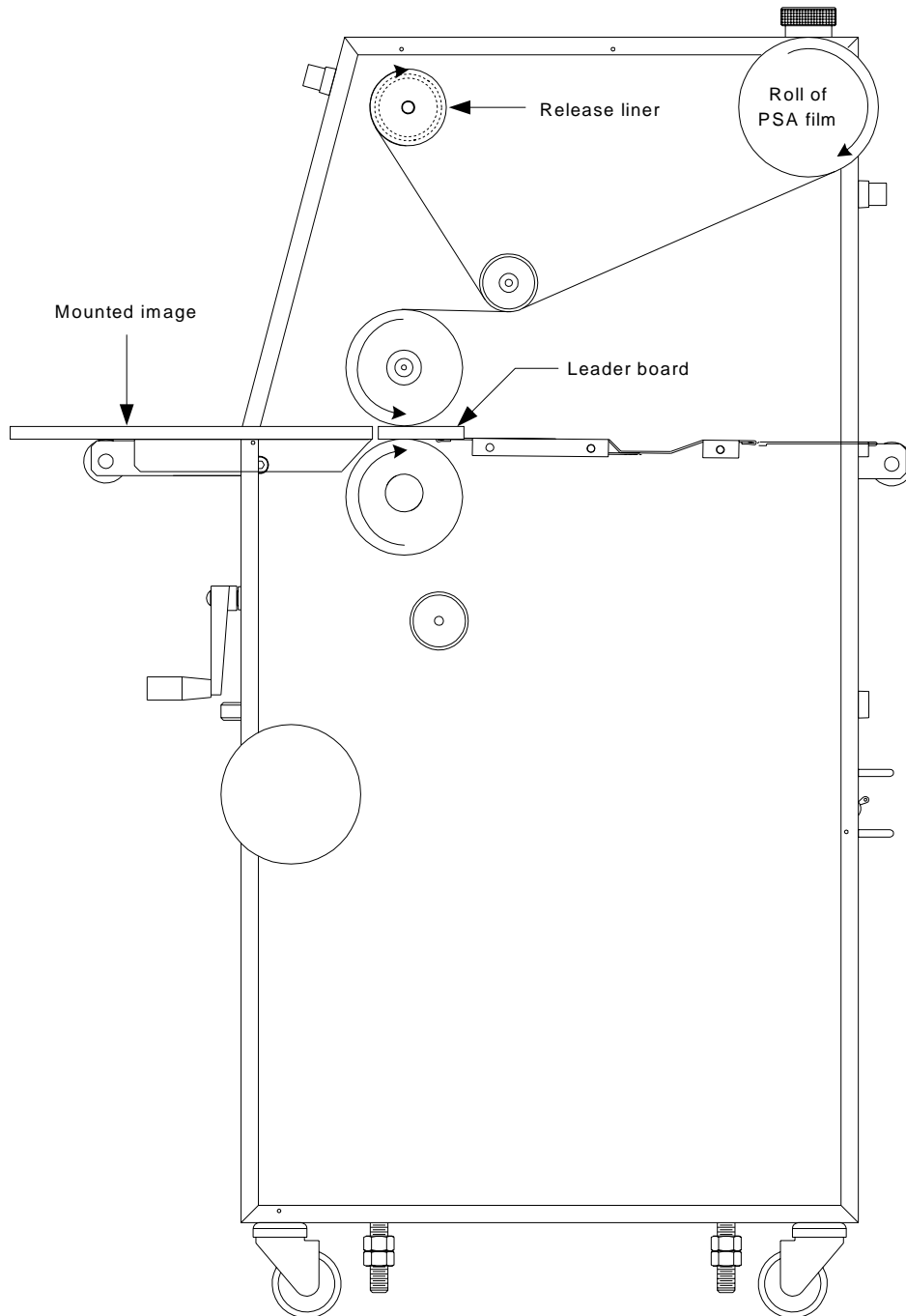

PROCESS CONTROL CHART

Materials - Lo-Melt over-lamination of a mounted image

Top material : Roll of Lo-Melt film

Bottom material : N/A

Other material (s) : A pre-mounted image to a board, leader board and trailer board

Motor Direction

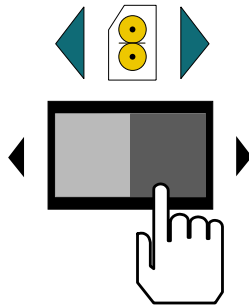

Heater

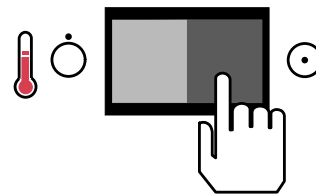

Motor Speed

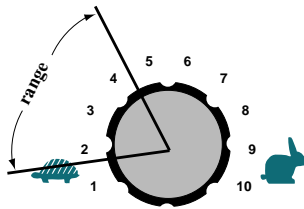

Upper Roller Temperature



RANGE



Roller Pressure

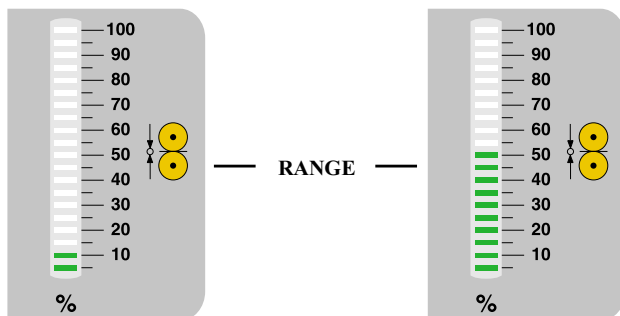

Notes : The laminate should not exceed the pre-mounted image by more than 3 in. ( 7.6 cm ). Speed will be determined by what is comfortable with the operator. Pressure is dependent on the substrate. Do not crush the substrate. Use a leader board to start the process and finish with a trailer board. Stopping on the image will leave an impression on the board or image. Heat is dependent on the thickness of the film. Refer to helpful hints for Lo-Melt films and mounting.

# Diagram - Lo-Melt over-lamination of a mounted image

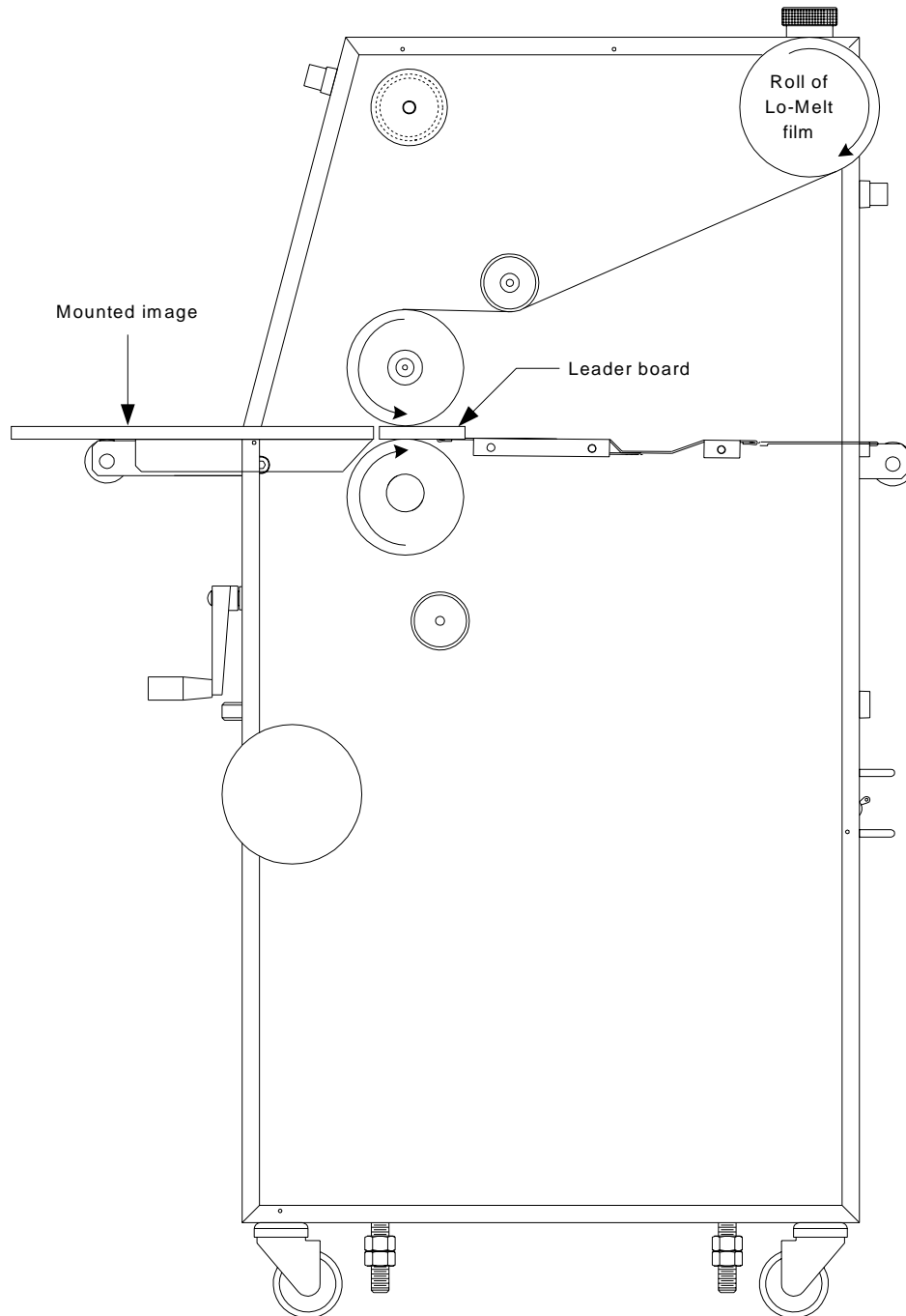

*This page intentionally left blank.*

## 7.0 Troubleshooting



### WARNING

Do not wear ties, loose fitting clothing or dangling jewelry while operating or servicing the laminator. These items can get caught in the nip and choke you or you can be crushed or burned.

As an operator, you can perform some simple troubleshooting in attempt to correct your typical output type problems. Use the easy to follow guide for assistance.

**Problem:** D waves in the image but not in the laminate

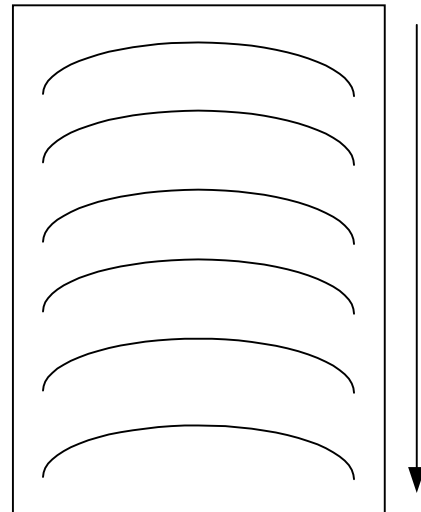

- Hints:**
- Check paper tension
  - Check relative moisture content of the paper

## 7.1 Wave problems

The following is a list of common output wave problems you may encounter.

The arrow along the length of the output represents the direction of feed ( travel ).

**Problem:** D Waves in the laminate

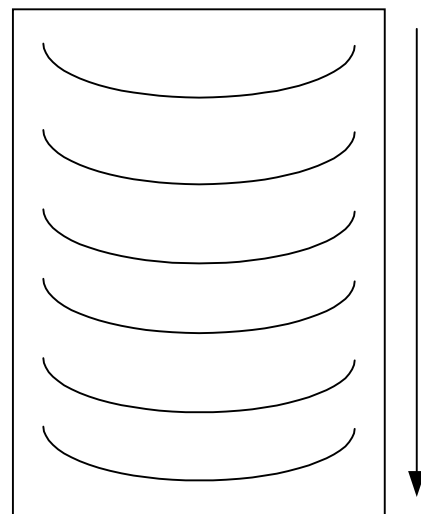

### INFORMATION

For optimal temperature settings of various laminates, contact your supplier or sales representative.

- Hints:**
- Check the roll pressure
  - Check the main roll nip settings

**Problem:** Straight waves in the output

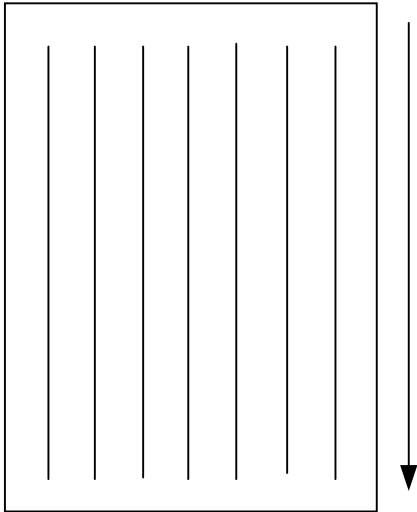

**Hints:** • Check operational settings for materials being used.

**Problem:** Angled waves in the output on both sides

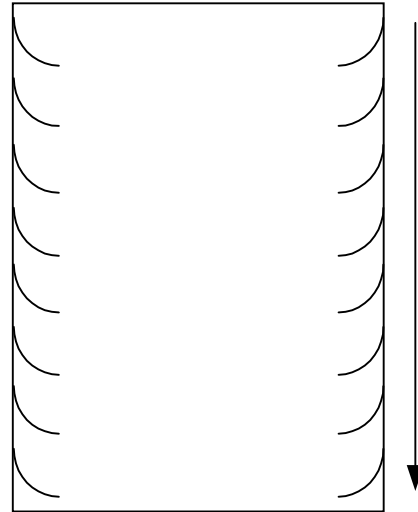

**Hints:** • Check for insufficient main roller pressure  
• Check the main roller nip settings

**Problem:** Waves on only one side of the output

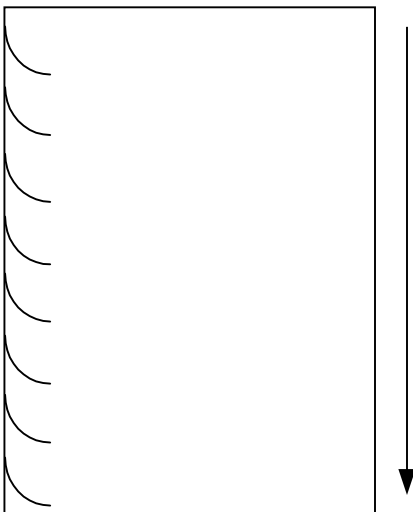

**Hints:** • Check the nip setting of main rolls  
• Check for even paper tension

**Problem:** Indent waves in output after the pull rollers

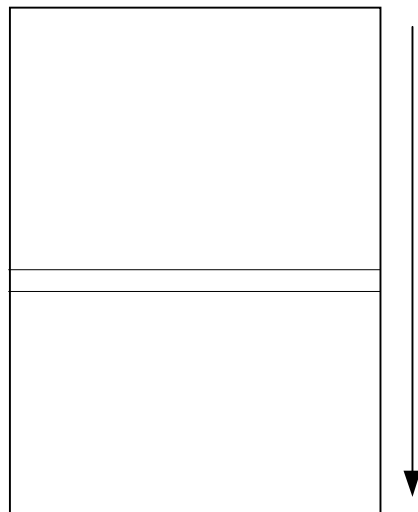

**Hints:** • Output travel was hindered  
• Allow output to cool before handling  
• Check operating temperatures of material

## 7.2 Film problems

The following is a list of common film problems you may encounter.

For definitions of terminologies, please refer to **7.4 Glossary of terminology**.

### *Pressure sensitive*

**Problem :** Silvering in the laminate

**Hints :**

- Add 100 - 120°F ( 37 - 49°C ) to the temperature
- Increase pressure to laminating rolls

**Problem :** Tunneling

**Hints :**

- Print should be wound image side out.
- Do not roll tightly
- Do not roll at all.

**Problem:** Delamination

**Hints:**

- Check operating pressures
- Check operating speed
- Laminate compatibility with ink
- Ink compatibility with paper

## *Lo-Melt laminates*

**Problem:** Blistering within the image

**Hints:**

- Increase the speed
- Decrease the operating temperature
- Allow a longer drying time for the image

**Problem:** Silvering in the laminate

**Hints:**

- Decrease the speed
- Increase the operating temperature

**Problem:** Delamination

**Hints:**

- Check operating temperatures
- Check operating speed
- Laminate compatibility with ink
- Ink compatibility with paper

## *Mounting*

**Problem :** Image creases when mounting

**Hints :**

- Press down on leading edge from center outwards.
- Be sure image is conformed to the roll
- Use a speed you are comfortable with
- Be sure even tension is supplied to the image

### 7.3 Machine problems

Once the **Hints** are all checked, and your problem still exists, a service call must be placed for a qualified service personnel to fix the problem.

You may do this by dialing 1 ( 800 ) 790 - 7787. This will connect you with GBC National Service dispatch. You will be required to give the serial number of your machine when placing a service call.

A space below has been provided to keep this number readily available if and when needed.

**My Falcon 60 H Laminator serial # is :**

---

At no time does GBC Films Group suggest or recommend that you attempt to fix the machine by removing the cabinets or leg covers yourself.



**WARNING**

Do not wear ties, loose fitting clothing or dangling jewelry while operating or servicing the laminator. These items can get caught in the nip and choke you or you can be crushed or burned.

**Problem :** No illumination to the control panel

- Hints :**
- Ensure an E-STOP has not been pushed down
  - Press **RESET**.
  - Confirm that the **MAIN POWER** is to the on position.
  - Be sure power is supplied to the laminator

**Problem :** I can only operate using the footswitch.

- Hints :**
- Ensure the **PHOTO-EYE** is not blocked.
  - Place a service call to calibrate sensors.

**Problem :** I press **ENGAGE**, the rollers will not turn.

- Hints :**
- Be sure a speed has been set.
  - Make sure a motor direction has been selected.
  - Ensure the **PHOTO-EYE** is not blocked.

**Problem :** Jerking, stuttering, or excessive noise from the laminator.

- Hints :**
- Check for excessive brake tension
  - Confirm that the rolls of laminate are on correctly.
  - Check for proper chain tension.
  - Place a service call.

## 7.4 Glossary

The glossary can help you in understanding some of the terminology used when referring to the laminator, applications, or troubleshooting aspects of the machine.

### Blistering

A condition where the paper coating is bubbled up from the image paper causing a “blister”. It is created by using excessive heat during the lamination process. Blistering is most commonly found with photographic and ink jet media.

### Bond strength

Refers to one of three conditions; 1) the anchor strength of adhesive to laminate substrate, 2) the anchor strength of the laminating film to the product that has been laminated, or 3) when two layers of film are laminated together, the strength of the adhesive to adhesive bond.

### Center mount

A mounting technique where an image is mounted centrally on a substrate to provide a decorative border.

### Coiling

A term used to describe an image rolling up on itself. This is caused by differences in the brake tension used between the upper and lower laminates during and application process.

### Cold laminate

Film that does not require heat to activate the adhesive. Please see P.S.A. for more information.

### Craft paper

A strong brown paper commonly used for single sided applications.

### D waves

A term used to describe a wave pattern caused, generally, by incorrect paper tension.

### Delamination

Refers to either one of two conditions; 1) the adhesive separating from the laminate substrate, or 2) the laminate separating from the product being laminated.

### Edgewrap

A mounting technique where the image wraps around the edges of the mounting substrate so as to provide a finished edge.

### Encapsulation

When an image is completely encased in laminating film, it is encapsulated. A border of laminate on laminate exists around the perimeter of the product.

### Film

A two part material consisting an adhesive layer and a substrate. The adhesive and the substrate may or may not be clear. This is the material used for lamination. Please refer to laminate.

**Foamboard**

A material commonly used as a mounting substrate. It is made up of foam sandwiched between two layers of paper, or paper like media.

**Inkjet**

A term used to describe a type of printing where an ink is projected topically onto a paper or paper like media. This is a non contact form of printing.

**Laminate**

A two part material consisting of an adhesive layer and a substrate. The adhesive and the substrate may or may not be clear. This is the material used for lamination.

**Lo-Melt films**

This is another type of thermal laminate. The name Lo-Melt describes this product simply. Low heat to activate ( melt ) the adhesive. Any temperature below boiling point is typically considered to be low.

**Main rollers**

These are the rolls that perform the actual lamination. They are rolls capable of being heated in thermal roll laminators and are usually larger in diameter than the pull rolls.

**Media**

Term used to describe the materials used to print an image, i.e. the papers, inks, toners, etc.

**Mount adhesive**

A term used to describe a two sided pressure sensitive adhesive used in mounting images to various substrates. This material can come with one or two release liners and may be optically clear for face mounting applications.

**Nip**

The interrelationship of any two rolls. The distance between the closest points of the two rolls is referred to as the nip of the rolls.

**P.S.A.**

Stands for **P**ressure **S**ensitive **A**dhesive. An adhesive that requires no heat to activate, only pressure. It is employed by removing a protective release liner and then pressed onto the material to be laminated. This type of film is commonly used on materials that are temperature sensitive.

**Release liner**

A coated paper or other media used to protect the adhesive side of a pressure sensitive material.

**Rewind**

A system that rolls up media. The rewind tube (s) used on the Falcon 60 H laminator is a prime example.

**Roll to roll**

On a laminator, this means the roll of images, upper roll of material and the lower roll of material can be fed by the machine and wound on a rewind roll by the machine.

**Scarring**

The visual effect of folding papers or laminates and breaking the surface. When done to a printed material it will be seen as a white crack in the image.

**Second surface**

A term to denote the back side of a substrate. Commonly referenced when discussing front mounted images to a clear substrate with an optically clear mount adhesive.

**Silvering**

A term used to describe one of two occurrences; 1) air bubbles trapped between the product and a thermal laminate, generally caused by insufficient heat being applied to the laminator or 2) the adhesive not fully activated in a pressure sensitive film, which will disappear once the adhesive is fully activated. This activation process can be sped up if a small amount of heat is applied during the application.

**Substrate**

The material to which an adhesive is to be bonded. In film, the substrate is the polyester and in mounting, the substrate is the material being mounted to.

**Tunneling**

When a laminated image is rolled up for any period of time and the laminate separates from the image. Generally in a pattern that follows the direction the laminated image was rolled up in. This is very common with pressure sensitive laminates and finished products that have been wound tightly.

**Unwind**

A system that unwinds media. Unwinds are used on all laminators to dispense laminate for lamination.

**Web**

The path that rolled media unwinding from a supply roll takes through a machine or array of rollers.

*This page intentionally left blank.*

## 8.0 Maintenance

GBC Films Group laminators require minimal maintenance. However, regular maintenance is essential to keep any piece of precision machinery at peak performance. A maintenance schedule and a section of procedures are included in this section.



### WARNING

Do not wear ties, loose fit clothing or dangling jewelry while operating or servicing the laminator. These items can get caught in the nip and choke you or you can be crushed or burned.



### INFORMATION

Improper maintenance, can result in poor output quality.



### ELECTRICAL SHOCK

Remove power from the laminator before servicing. You can be severely shocked, electrocuted or cause a fire.

## 8.1 Maintenance Schedule



### INFORMATION

Below is a recommended maintenance schedule. Before performing any of the steps listed, read through the procedures first. Please follow the instructions pertaining to the step you are performing.

### *Daily*

- Clean the rollers  
( See cleaning in this section )
- Inspect the electrical cord for damage.  
( If damaged, you should replace or repair it immediately )
- Inspect the footswitch cord for damage.  
( If damaged, you should replace or repair it immediately )

### *Monthly*

- Adjust the nip if needed.  
( performed by service technician )
- Check the chain tension.  
( performed by service technician )
- Inspect the area around the laminator for possible hazards  
( dust buildup, combustible items stored too close, etc. )

*Semi-Annual***8.2 Cleaning the rollers**

- Lubricate the grease fittings, chain, and gears.  
(performed by service technician)
- Check wire termination tightness.  
(performed by service technician)



**ELECTRICAL  
SHOCK**

Remove power from the laminator before servicing. You can be severely shocked, electrocuted or cause a fire.

*Tools required*

- Protective rubber gloves  
(This will protect your hands from the isopropyl alcohol)
- 80% isopropyl alcohol  
(a mild dishwashing detergent and water may be used instead)
- Rubber cement eraser  
(a belt sander dressing block may be used instead)
- Several 100% cotton terry cloths  
(best for lint free cleaning)

- a) Turn the main power to the **ON** position.

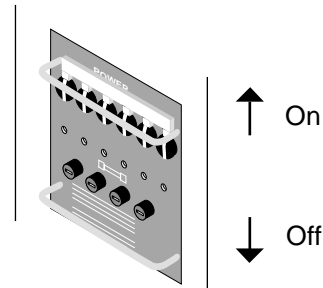

- b) Press machine **RESET**.

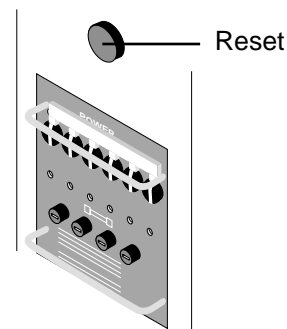

c) Set motor direction to **REV**.

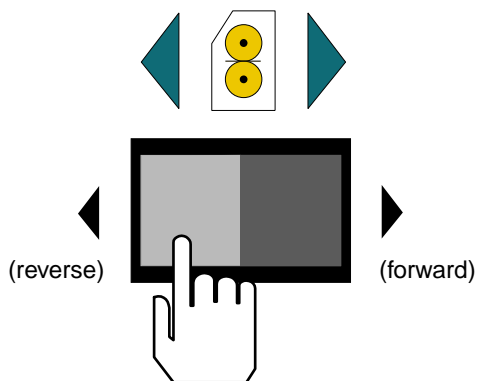

d) For pressure sensitive adhesives: put the rubber gloves on and use isopropyl alcohol and a terry cloth towel to rub the adhesive off.



**CAUTION**

Excessive pressure can destroy the silicone layer by pressing to hard or scrubbing too long in one spot.

e) For thermal adhesives: while the laminator is at normal operating temperature, put on the rubber gloves and use the rubber cement eraser. This allows the eraser to bead up the adhesive.

f) Wipe away the beads with isopropyl alcohol and a cotton terry cloth.

d) Use the footswitch to rotate the rollers when finished cleaning that area.



**CAUTION**

Exercise care when cleaning the laminating rollers with 80% isopropyl alcohol:

- Use only in a well ventilated area
  - Wear rubber gloves
  - Use only on cool rolls

**CLEANING HEATED ROLLERS CAN IGNITE THE FUMES!**



**CAUTION**

Do **NOT** pick or pull heat activated adhesive off the rolls when they are cold. You can cause irreparable damage to the laminating rolls.



**WARNING**

When operating the laminator using the footswitch, keep hands and fingers away from the nip of the rollers. You may be **CRUSHED** or **BURNED**!

### 8.3 Clean cabinets and covers

### 8.4 Clean the control panel



**ELECTRICAL  
SHOCK**

Remove power from the laminator before cleaning. You can be severely shocked, electrocuted or cause a fire.

a) Use a damp cotton terry cloth ( water only ), clean the exterior of the laminator.

b) If water is not strong enough, you may use a mild dishwashing detergent with water and a cotton terry cloth.



**ELECTRICAL  
SHOCK**

Remove power from the laminator before cleaning. You can be severely shocked, electrocuted or cause a fire.

a) Use only a slightly damp ( water only ) non abrasive cloth.

b) The same type of cloth used to clean eye glasses may be used instead.



**ELECTRICAL  
SHOCK**

Do not use liquid or aerosol cleaners on the laminator. Do not spill liquid of any kind on the laminator. You can be severely shocked, electrocuted or cause a fire. Use only a damp cloth for cleaning unless other wise specified.



**ELECTRICAL  
SHOCK**

Do not use liquid or aerosol cleaners on the laminator. Do not spill liquid of any kind on the laminator. You can be severely shocked, electrocuted or cause a fire. Use only a damp cloth for cleaning unless other wise specified.

## 8.5 Chain tensioning

A properly tensioned chain should have a 1/2 in (1.3 cm) of total play at the longest stretch of the chain. Read and understand the precautions below before attempting any service work.



### WARNING

Do not wear ties, loose fit clothing or dangling jewelry while operating or servicing the laminator. These items can get caught in the nip and choke you or you can be crushed or burned.



### WARNING

Remove ALL power to the laminator before removing any cabinet covers. You may be shocked or electrocuted!



### WARNING

Always practice lock out/ tag out procedures when performing any type of service or maintenance work on the machine.

## Tools required

- 1/8 inch allen wrench
- 7/16 inch wrench or socket

a) Ensure all power to the laminator has been removed.

b) Use proper lock out/ tag out procedure.

c) With a 1/8 in. allen wrench, remove the drive side cabinet cover by;

1) Loosen the three screws along the bottom.

2) Remove the seven screws along the top and sides of the cover.

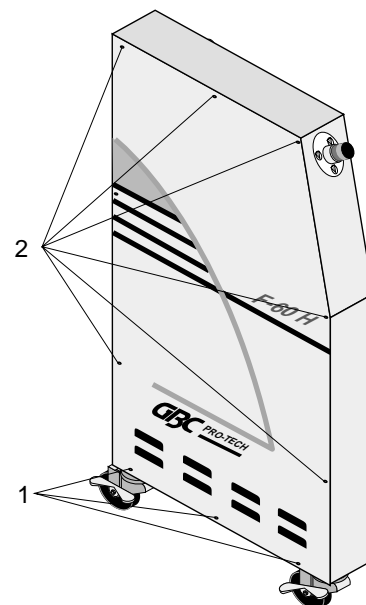

- d) Check the primary chain ( outer ) and the secondary chain ( inner ) for proper chain tension.

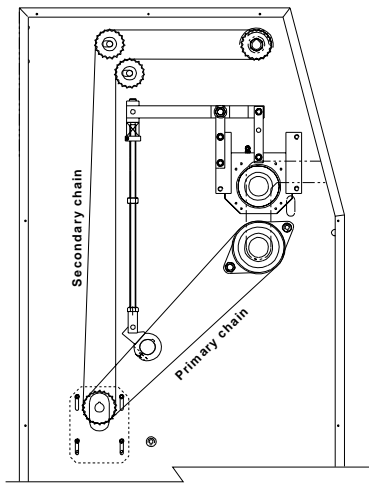

- f) Press firmly down on the motor housing and tighten the motor mount bolts.

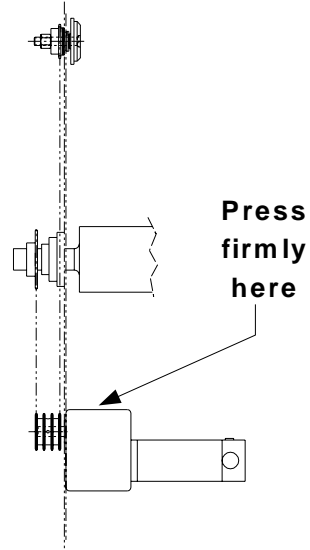

- e) If the chains require tensioning, loosen the four motor mount bolts with a 7/16 in. wrench.

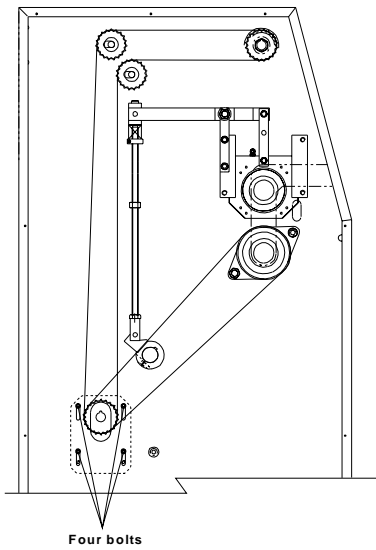

- g) Check the primary chain ( outer ) and the secondary chain ( inner ) again for proper chain tension.

- h) Replace the drive side cabinet cover and restore power to the machine.



**INFORMATION**

**The motor controls the tension of the both chains. If one is chain is still too loose, a half link may be removed.**