

---

---

# F-36 Series II Operation and Maintenance Manual

---

---

© 1998 GBC Pro-Tech  
Do not duplicate without written permission

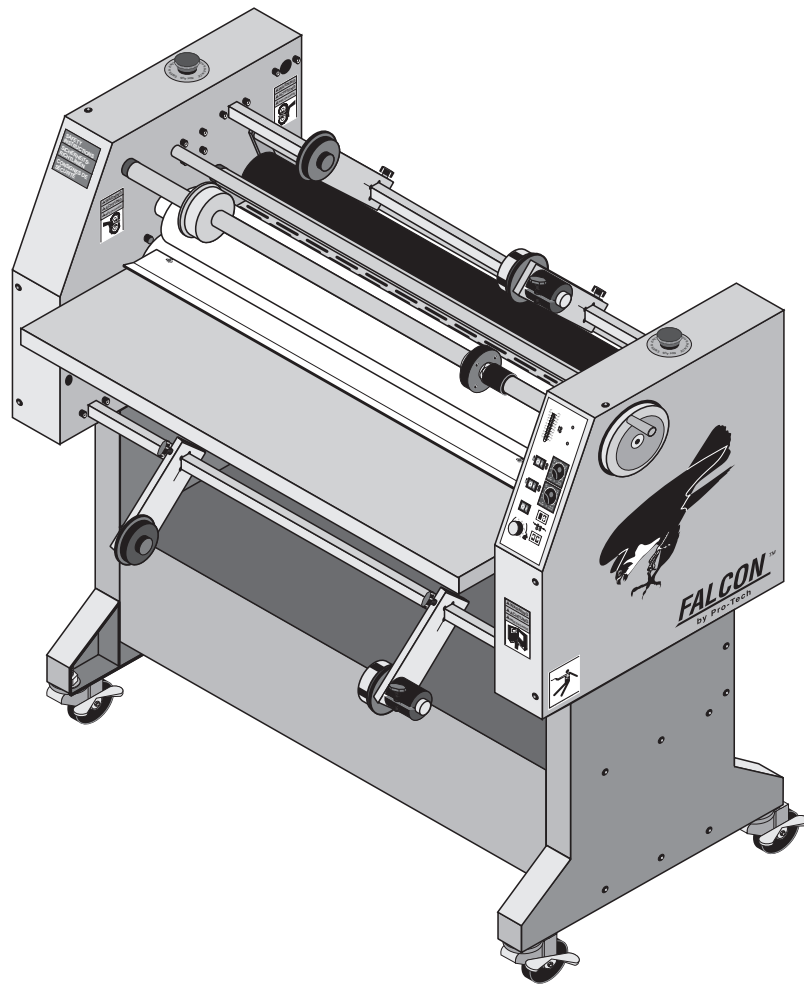

Part Number 930-017 Rev. A

**GBC Pro-Tech**  
4151 Anderson Road  
De Forest, Wisconsin 53532  
Tel: 608-246-8844  
Fax: 608-246-8645

*The information in this publication is provided for reference and is believed to be accurate and complete. GBC Pro-Tech is not liable for errors in this publication or for incidental or consequential damage in connection with the furnishing or use of the information in this publication, including, but not limited to, any implied warranty of fitness or merchantability for any particular use.*

*GBC Pro-Tech reserves the right to make changes to this publication and to the products described in it without notice. All specifications and information concerning products are subject to change without notice.*

*Reference in this publication to information or products protected by copyright or patent does not convey any license under the rights of GBC Pro-Tech or others. GBC Pro-Tech assumes no liability arising from infringements of patents or any other rights of third parties.*

*This manual is copyrighted ©1998 by GBC Pro-Tech. All rights reserved. The information contained in this manual is proprietary and may not be reproduced, stored, transmitted, or transferred, in whole or in part, in any form without the prior and express written permission of GBC Pro-Tech.*

## Table of Contents

<b>Section 1 : Safety</b> .....	<b>1-1</b>
Caution/Warning Label Locations .....	1-4
<b>Section 2 : Installation</b> .....	<b>2-1</b>
Preinstallation Checklist.....	2-1
Unpacking.....	2-3
Setup .....	2-6
Startup .....	2-8
<b>Section 3 : Operation</b> .....	<b>3-1</b>
Safety.....	3-1
Operator Controls .....	3-2
Front Control Panel.....	3-2
Setup .....	3-3
Laminator Roll Pressure .....	3-3
Loading the Film .....	3-3
Positioning the Film .....	3-3
Heating .....	3-4
Cooling.....	3-4
Paper Tips.....	3-4
Process Control Charts.....	3-5
Mounting and Laminating (One Pass) .....	3-5
Setup and Procedure .....	3-5
Mounting Only.....	3-6
Setup and Procedure .....	3-6
Two-Pass Mount and Laminate (Cold Overlamine) .....	3-6
Setup and Procedure, Pass 1 .....	3-6
Setup and Procedure, Pass 2 .....	3-7
Two-Pass Mount and Laminate (Hot Overlamine).....	3-7
Setup and Procedure, Pass 1 .....	3-7
Setup and Procedure, Pass 2 .....	3-7
Encapsulation .....	3-8
Setup and Procedure .....	3-8
Machine Shutdown .....	3-8
Procedure .....	3-8

**Section 4 : Maintenance and Troubleshooting .....4-1**

- Thermocouple Positioning and Cleaning..... 4-1
- Adjusting the Nip ..... 4-5
- Chain Tensioning..... 4-6
- Lubrication ..... 4-6
- Contacting Technical Support..... 4-7
- Output Troubleshooting Guide..... 4-8

**Section 5 : Warranty .....5-1**

- Limited Warranty..... 5-1
- Exclusions to the Warranty ..... 5-1

**Section 6 : Specifications .....6-1**

## Section 1 : Safety

**DO NOT ATTEMPT TO OPERATE YOUR F-36 SERIES II LAMINATOR UNTIL YOU HAVE READ THIS SECTION CAREFULLY!**

Your safety, as well as the safety of others, is important to GBC Pro-Tech. This section contains important safety information.

The following symbols are used throughout this manual to indicate warnings and cautions.



**DANGER**

**Indicates an imminently hazardous situation which, if not avoided, will result in death or serious injury.**



**WARNING**

**Indicates a potentially hazardous situation which, if not avoided, could result in death or serious injury.**



**CAUTION**

**Indicates a potentially hazardous situation which, if not avoided, could result in minor or moderate injury, or alerts against unsafe practices, or alerts against actions which could damage the product.**

The F-36 Series II Laminator has been designed with safety as a primary consideration. However, you must become thoroughly familiar with the controls, proper operation, proper service procedures, and safety features of the laminator before using or servicing the unit.

GBC Pro-Tech laminators are powerful machines that are designed to mount, laminate and encapsulate. The forces required to accomplish these tasks can vary from negligible to very large.

The spring system used to provide downward pressure on the top roll is capable of producing forces greater than 1000 pounds (454kg). This force is applied to any object presented in the opening (called the nip) between the two rolls.

In addition, the laminating rolls of the F-36 Series II can reach temperatures of over 200°F (100°C). At these temperatures there is a danger of a severe burn if the rolls are touched during set-up, operation or servicing.

An important feature of the laminator is the photoelectric eye system that stops the machine when objects move into the nip area. Once the blocking object is removed and the light beam reestablished, the rolls resume turning. However, this system is overridden if you use the footswitch.



**WARNING**

**Use extreme caution when operating the laminator with the footswitch. The photoelectric eye system is overridden and your fingers can get caught in the nip. You can be crushed or burned.**

The F-36 Series II Laminator has a steel cabinet that is bolted closed to isolate the electrical and drive system components for the safety of the operator. Only a qualified service technician should open these cabinets.

The laminator is equipped with two emergency stop buttons located on the top of either side of the laminator. Either of these, if engaged, stops the laminator. To continue operation both emergency stop buttons must be in the up position.

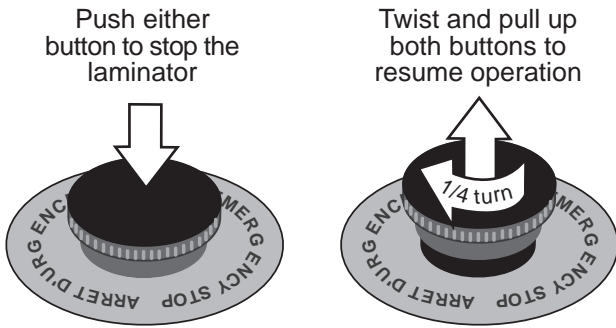

Figure 1-1: Using the Emergency Stop Buttons

Despite the safety features built into the F-36 Series II Laminator, extreme caution must be used when operating or servicing the unit. **READ THE FOLLOWING WARNINGS AND CAUTIONS BEFORE YOU ATTEMPT TO OPERATE OR SERVICE THE F-36 SERIES II LAMINATOR.**



**WARNING**

Never place fingers or arms between the rolls when they are turning or when the rolls are in the closed position. You can be crushed or burned.



**WARNING**

Secure long hair so that it cannot get caught in the machinery. Do not wear ties, loose fitting clothing or dangling jewelry while operating or servicing the laminator. These items can get caught in the nip, and you can be choked, crushed, or burned.



**WARNING**

Use extreme caution when operating the laminator with the footswitch. The photoelectric eye system is overridden and your fingers can get caught in the nip. You can be crushed or burned.



**CAUTION**

**ALWAYS CHECK THE INFRARED SENSORS PRIOR TO OPERATION!** The sensors must be clean and have free view of the roll to maintain proper roll operating temperatures. The rolls can overheat and cause a fire or seriously damage the laminator.



**WARNING**

Always use care in lowering the top laminating roll. You can be crushed or burned.



**WARNING**

Do not operate the laminator near water. You can be severely shocked, electrocuted or cause a fire.



**DANGER**

Unplug the laminator from the wall outlet and lockout power switch before servicing. You can be severely shocked, electrocuted or cause a fire.

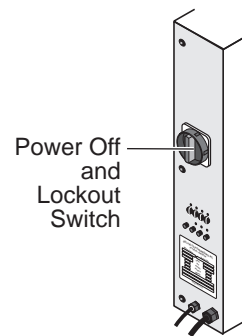

Figure 1-2: Rear of Control Cabinet Lock Out Power Switch

**WARNING**

Do not use liquid or aerosol cleaners on the laminator. Do not spill liquid of any kind on the laminator. You can be severely shocked, electrocuted or cause a fire. Use only a damp cloth for cleaning the cabinet.

**CAUTION**

If silicone adhesive contacts the upper or lower roll, remove it **IMMEDIATELY** using 80% isopropyl alcohol. It can harden within an hour and ruin the roll.

**WARNING**

Exercise care when cleaning the rolls with 80% isopropyl alcohol:

- Use only in a well ventilated area.
  - Wear rubber gloves.
  - Use only on cool rolls.

Cleaning heated rolls can ignite the fumes.

**WARNING**

The operating environment must be free of dust, flammable liquids and vapors. You can be injured by inhaling chemical vapors. Vapor build up or stored flammable liquids can cause a fire. Excessive dust can damage the laminator.

**CAUTION**

Do not use a knife or other sharp instrument during installation or while servicing the laminator. You can cause irreparable damage to the rolls.

**CAUTION**

Use only 80% isopropyl alcohol or a rubber cement eraser to clean the laminating rolls. Harsh chemicals like toluene, acetone or MEK destroy the silicone covering of the rolls.

**WARNING**

Do not attempt to move the laminator across anything other than a flat, level surface without trained and qualified riggers. You can be crushed or seriously injured.

**CAUTION**

Raise the upper main roll when the laminator is not in operation. Prolonged contact can damage the rolls.

**CAUTION**

Excess pressure can damage the laminating rolls. Always select the minimum roll pressure necessary to complete the task.

The F-36 Series II Laminator is a large and heavy piece of equipment. It is necessary to employ **LICENSED RIGGERS ONLY** to move the machine. The laminator is not designed to be tipped up or sideways in any way. Such action disturbs the exact alignment of the rolling parts of the machine and requires extensive realignment. GBC Pro-Tech's warranty does not cover malfunction of the equipment due to mishandling and/or tipping.

GBC Pro-Tech bears no responsibility for personal injury or damage due to moving the laminator improperly.

**WARNING**

Connect the laminator only to the type of power source indicated on the label on the back of the laminator. You can be severely shocked, electrocuted or cause a fire. If you are not sure of the type of power available consult the dealer or local power company.

**WARNING**

Do not attempt to plug any device into the vacuum table outlet that does not require 240V. You can be severely shocked, electrocuted or cause a fire.

**WARNING**

Do not attempt to defeat the grounding feature of the ground plug on the laminator. You can be severely shocked, electrocuted or cause a fire. The three prong plug fits only into a grounding-type power outlet. If you are unable to insert the plug into the existing outlet, contact a qualified electrician to replace the obsolete outlet.

**WARNING**

Never insert objects of any kind through any of the slots on the laminator. You can touch dangerous voltage points or short out parts. You can be severely shocked, electrocuted or cause a fire.

ALWAYS USE GOOD SAFETY PRACTICES WHEN OPERATING OR SERVICING THE LAMINATOR AND KNOW HOW TO REACT QUICKLY IN AN EMERGENCY.

**WARNING**

Do not use an extension cord on this laminator. You can be severely shocked, electrocuted or cause a fire. If you need a longer cable contact a qualified electrician.

**Caution/Warning Label Locations**

Posted at various locations on your F-36 Series II Laminator are important safety labels. PAY CAREFUL ATTENTION TO THESE LABELS AT ALL TIMES! Figure 1-2 shows the location of each of these labels.

**WARNING**

Do not operate the laminator if the power cord is damaged or frayed. You can be severely shocked, electrocuted or cause a fire. Contact a qualified electrician to replace the cord.

**WARNING**

Do not allow anything to rest on the power cord. Do not locate the cord where people can walk on it. You or others can be severely shocked, electrocuted or cause a fire.

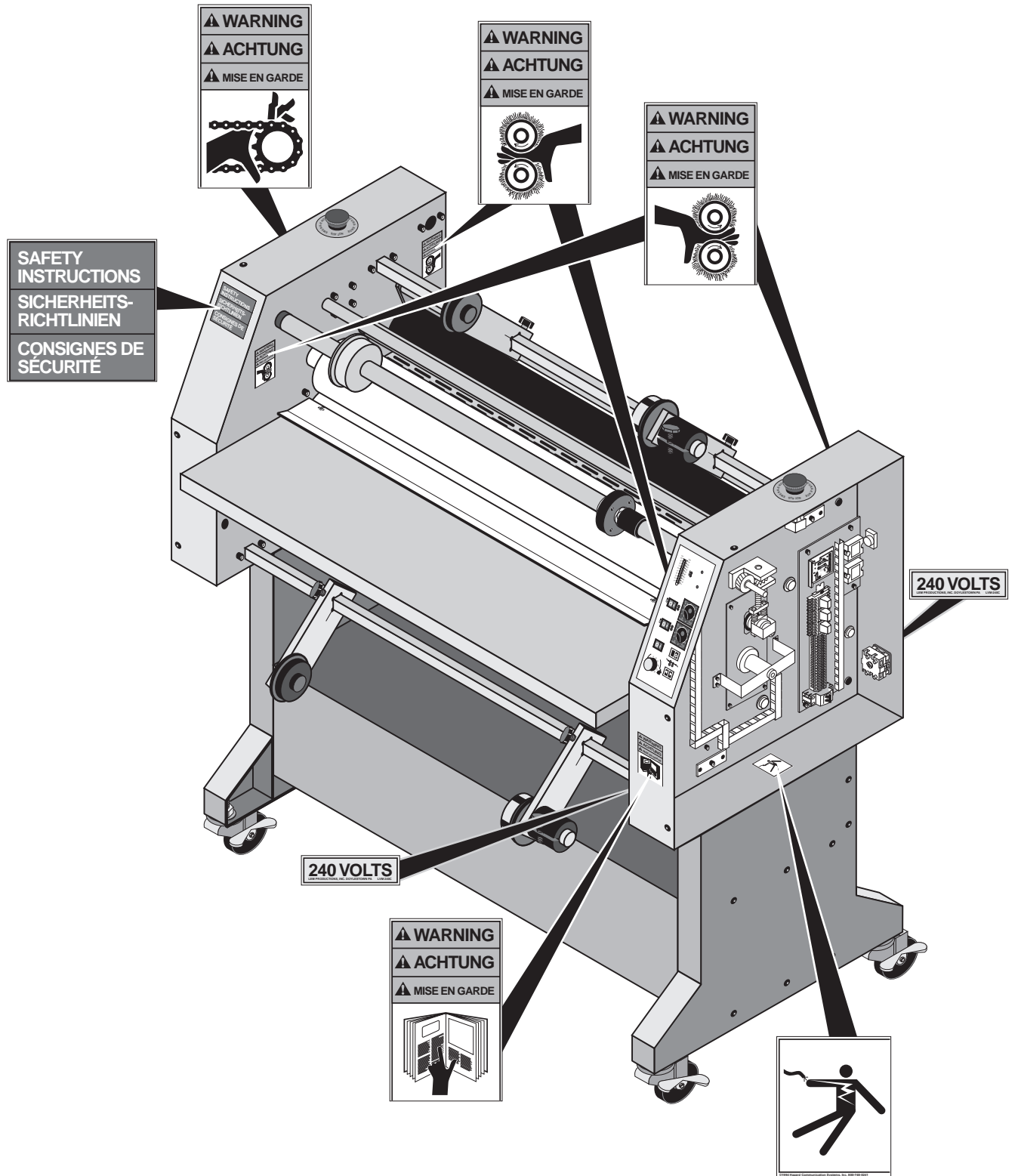





Figure 1-3: Locations of Safety Labels

The following are typical safety hazard decals used on GBC Pro-Tech machines, with a brief description (“Meaning” column) of each decal.

Decal	Meaning
	<p><b>WARNING!</b></p> <p>Moving parts can crush and cut.</p> <p>Do not operate with guard or door open.</p>
	<p><b>WARNING!</b></p> <p>Crush and burn hazard. Stay clear of moving rollers. Stop machine and raise roll before cleaning.</p>
	<p><b>WARNING!</b></p> <p>Carefully read Operator's Manual before handling this machine. Observe instructions and safety rules when operating.</p>
	<p><b>WARNING!</b></p> <p><b>HAZARDOUS VOLTAGE.</b></p> <p>To be serviced only by trained and authorized personnel.</p> <p>Lockout power before servicing.</p>
	<p><b>CAUTION!</b></p> <p>Surface is hot.</p> <p>A burn hazard exists.</p>
	<p><b>CAUTION!</b></p> <p>Rolls are heavy. Use proper lifting techniques to prevent injury.</p>

Decal	Meaning
	<p><b>WARNING!</b></p> <ol style="list-style-type: none"> <li>1. Read and understand the Operation Manual and all safety labels before operating this machine.</li> <li>2. Only a trained person is to be permitted to operate this machine. Training should include instruction in operation under normal conditions and emergency situations.</li> <li>3. This machine is to be serviced only by trained and authorized personnel. Follow lockout procedures before servicing.</li> <li>4. Never reach into the machine for any reason unless the machine is at a COMPLETE STOP.</li> <li>5. Never leave the machine stopped in such a manner that another worker can start the machine while you are working on or within the machine.</li> <li>6. Never change or defeat the function of electrical interlocks or other machine "shutdown" switches.</li> <li>7. Before starting this machine, check that:             <ul style="list-style-type: none"> <li>- All persons are clear of the machine.</li> <li>- No maintenance work is being performed on the machine.</li> <li>- All guards are in place.</li> <li>- All parent rolls are well chucked in the unwind stands.</li> <li>- The machine is free of paper scraps, wraps and jams.</li> </ul> </li> <li>8. There is a potential hazard of entanglement in this machine caused by items such as long hair, loose clothing, and jewelry. Make sure your clothing and hair fit closely to your body and that all jewelry, rings and watches are removed.</li> </ol>
	<p><b>CAUTION!</b></p> <p>Air pressure must be less than 100 PSI (700 kPa) to avoid damaging the machine.</p>
	<p>Reset.</p>
	<p><b>WARNING!</b></p> <p><b>EMERGENCY STOP BUTTON</b></p> <p>Press this button to stop the machine cycle, remove electric power, and separate (open) rolls to eliminate a pinch point (on some machines).</p>

## Section 2 : Installation

Before an F-36 Series II Laminator can be installed there are a few requirements that must be met. Make certain that each of the requirements listed in the following preinstallation checklist are met before beginning installation.



**CAUTION**

**Failure to follow the preinstallation checklist can result in damage to the laminator.**

### Preinstallation Checklist

- Are doorways and hallways wide enough for the laminator to be moved to the installation site?
- Is there ample room for the laminator?  
A work area must be established that allows for operation in both the front and the rear of the machine and provides space for efficient material flow. Figure 2-1 shows a typical machine area layout.
- Is the environment appropriate for the laminator?  
The laminator requires a clean, dust and vapor free environment to operate properly, such as an air conditioned office area with forced 10% make up air. However, the laminator must not be located where there is air blowing directly on it. Major fluctuations in temperature and humidity are to be avoided.



**WARNING**

**The operating environment must be free of dust, flammable liquids and vapors. You can be injured by inhaling chemical vapors. Vapor build up or stored flammable liquids can cause a fire. Excessive dust can damage the laminator.**



**CAUTION**

**Do not locate the laminator where air is blowing directly on the machine. The air flow can cool the rolls unevenly and result in poor quality output.**

- Is there an appropriate power outlet available or has a certified electrician been contacted to wire the laminator directly?

The laminator requires 30A single phase service and a power receptacle that accepts a 30A 250V NEMA L6-30P plug or, in Europe, 3 phase, 240/400 VAC with 20A per phase. See Figure 2-6 for power cord connection options.



**CAUTION**

**Position the jumpers as shown in Figure 2-6 for service choice.**

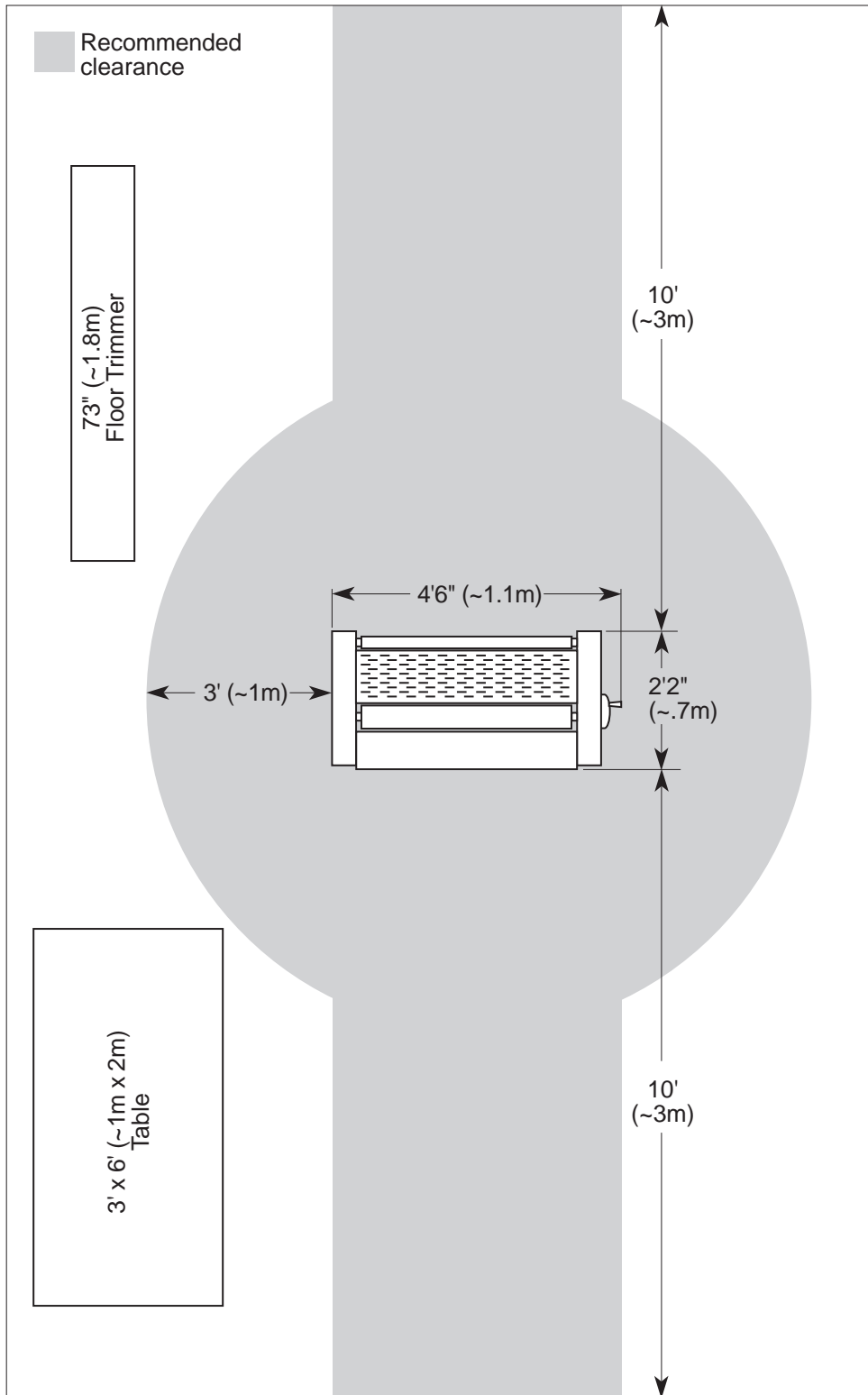

Figure 2-1: Laminator Space Requirements

## Unpacking

### NOTE

*ALL SHIPMENTS ARE EX- WORKS. At our dock, title passes to the buyer. Please review your insurance coverage prior to shipment, as you are responsible for all subsequent freight charges and risks. Before signing the Bill of Lading, be sure to inspect the crate and/or pallet for signs of damage or missing items; if applicable, make a note of this on the Bill of Lading.*

The F-36 Series II Laminator is shipped one of two ways. It is either encased in a plywood crate on a skid or in a cardboard box on a skid.



### WARNING

**The unpacking process requires at least two people. You can be severely injured or crushed.**

### Tools required:

- Phillips head screwdriver
- $\frac{7}{8}$ " open end wrench or adjustable wrench

### If the laminator is in a cardboard box:

1. Remove the securing screws around the bottom of the box using the Phillips head screwdriver as shown in Figure 2-2.

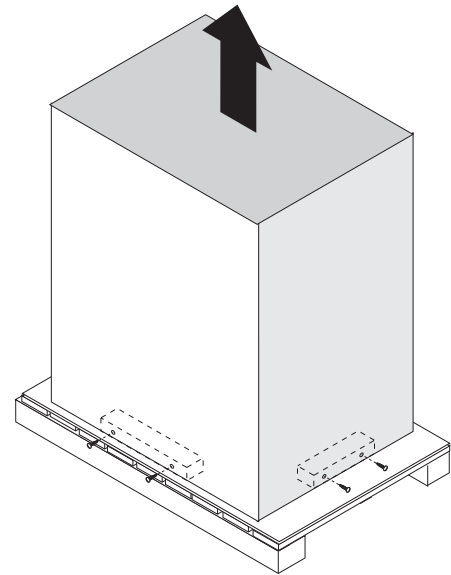

Figure 2-2: Removing the Cardboard Box

2. Lift the cardboard box off the laminator.
3. Gently unwrap the shrink wrap from around the laminator.



### CAUTION

**Do not use a knife or other sharp instrument during installation or while servicing the laminator. You can cause irreparable damage to the rolls.**

4. Carefully remove any accessories packed with the laminator. The accessory pack should contain:
  - 1 Set, hex wrenches
  - 1 Slitting knife
  - 1 Manual
  - 1 Set, spare fuses
  - 1 Tape measure
  - 1 Roll of masking tape
  - 1 Rubber cement eraser

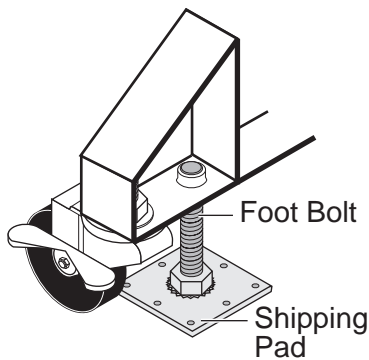

Figure 2-3: The Foot Bolts

5. Remove the screws holding the foot pads onto the pallet using the Phillips head screwdriver.
6. Have the laminator lifted off the skid and placed on the floor by licensed riggers. The riggers must also unscrew the foot bolts from the laminator frame since it requires lifting the laminator.



### WARNING

**Do not attempt to move the laminator across anything other than a flat, level surface without trained and qualified riggers. You can be crushed or seriously injured.**

**The F-36 Series II Laminator is a large and heavy piece of equipment. It is necessary to employ LICENSED RIGGERS ONLY to move the machine. The laminator is not designed to be tipped up or sideways in any way. Such action disturbs the exact alignment of the rolling parts of the machine and requires extensive realignment. GBC Pro-Tech's warranty does not cover malfunction of the equipment due to mishandling and/or tipping.**

**GBC Pro-Tech bears no responsibility for personal injury or damage due to moving the laminator improperly.**

7. Once the laminator is in place set the locking mechanism on all four wheels to ON.
8. Remove any plastic strapping and packing paper taped to the rolls.



### CAUTION

**Do not use a knife or other sharp instrument during installation or while servicing the laminator. You can cause irreparable damage to the rolls.**

9. Remove all packing materials to a safe distance from the laminator.

#### ☞ A NOTE ABOUT RECYCLING

*The pallet can be reused for shipping the machine again, or can be disassembled and the wood and screws recycled. The cardboard can be recycled. The shrink wrap is not recyclable, however, so it must be discarded.*

#### ☞ NOTE

*A word about international shipments: As these are heavy pieces of equipment, GBC Pro-Tech takes every precaution to ensure that our laminators are properly crated to the highest standards.*

*Before machines leave our loading dock, they are pre-treated with a VCI protective film to provide total corrosion protection. This protective film is wrapped around the machine and completely sealed. In addition, moisture absorbing silicone desiccite packs are packed inside the crate and machine cabinets.*

*Prior to start up of the machine, you must remove the desiccite packs from each cabinet and discard. DO NOT operate the machine with the desiccite packs inside the cabinets.*

**If the laminator is in a crate:**

1. Remove the top of the crate and then the sides in the order shown in Figure 2-4.



**CAUTION**

**Do not allow the top to fall into the crate. It can damage the laminator.**

**Do not put packing screws on the floor. They can cause problems when trying to roll the machine into position.**

**A second person must support the side labeled 5 in Figure 2-4. It can fall and damage the laminator.**



**CAUTION**

**Do not use a knife or other sharp instrument during installation or while servicing the laminator. You can cause irreparable damage to the rolls.**

3. Carefully remove any accessories packed with the laminator. The accessory pack should contain:
  - 1 Set, hex wrenches
  - 1 Slitting knife
  - 1 Manual
  - 1 Set, spare fuses
  - 1 Tape measure
  - 1 Roll of masking tape
  - 1 Rubber cement eraser

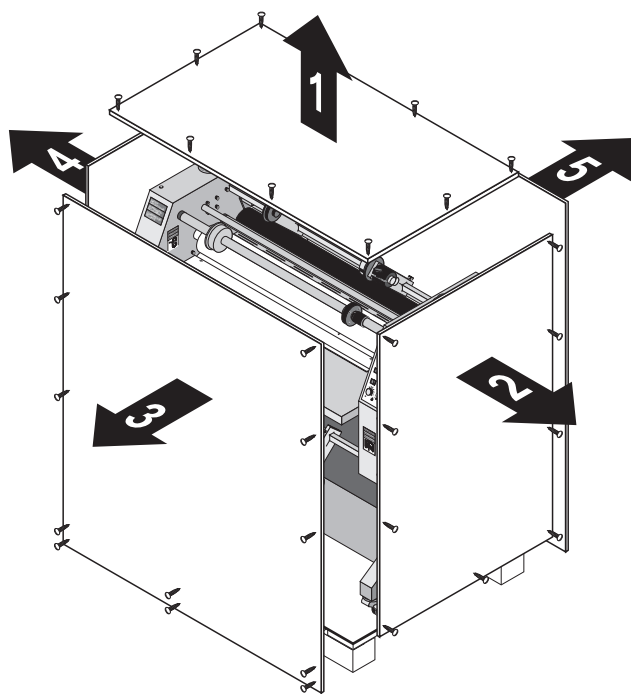

*Figure 2-4: Removing the Crate*

2. Gently unwrap the shrink wrap from around the laminator.

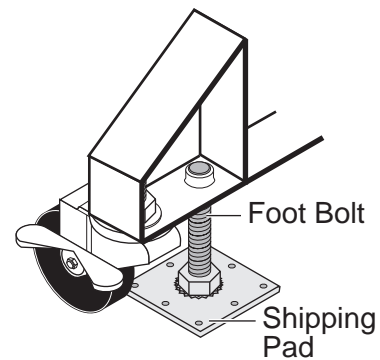

*Figure 2-5: The Foot Bolts*

4. Remove the screws holding the foot pads onto the pallet using the Phillips head screwdriver.
5. Have the laminator lifted off the skid and placed on the floor by licensed riggers. The riggers must also unscrew the foot bolts from the laminator frame since it requires lifting the laminator.

**WARNING**

**Do not attempt to move the laminator across anything other than a flat, level surface without trained and qualified riggers. You can be crushed or seriously injured.**

**The F-36 Series II Laminator is a large and heavy piece of equipment. It is necessary to employ LICENSED RIGGERS ONLY to move the machine. The laminator is not designed to be tipped up or sideways in any way. Such action disturbs the exact alignment of the rolling parts of the machine and requires extensive realignment. GBC Pro-Tech's warranty does not cover malfunction of the equipment due to mishandling and/or tipping.**

**GBC Pro-Tech bears no responsibility for personal injury or damage due to moving the laminator improperly.**

6. Once the laminator is in place set the locking mechanism on all four wheels to ON.
7. Remove any plastic strapping and packing paper taped to the rolls.

**CAUTION**

**Do not use a knife or other sharp instrument during installation or while servicing the laminator. You can cause irreparable damage to the rolls.**

8. Remove all packing materials to a safe distance from the laminator.

 **A NOTE ABOUT RECYCLING**

*The crate components can be reused for shipping the machine again, or can be disassembled and the wood and screws recycled. The shrink wrap is not recyclable, however, so it must be discarded.*

 **NOTE**

*A word about international shipments: As these are heavy pieces of equipment, GBC Pro-Tech takes every precaution to ensure that our laminators are properly crated to the highest standards.*

*Before machines leave our loading dock, they are pre-treated with a VCI protective film to provide total corrosion protection. This protective film is wrapped around the machine and completely sealed. In addition, moisture absorbing silicone desiccite packs are packed inside the crate and machine cabinets.*

*Prior to start up of the machine, you must remove the desiccite packs from each cabinet and discard. DO NOT operate the machine with the desiccite packs inside the cabinets.*

**Setup**

Once the F-36 Series II Laminator has been unpacked and moved into final position check each of the following items.

**Tools required:**

- 1/8" hex wrench
- Adjustable wrench

**Setup Procedure**

1. Inspect the laminator for any obvious shipping damage.
2. Remove the drive and control side cabinet covers with the 1/8" hex wrench by removing the six screws holding each cover in place.
3. Inspect all the bolts and tighten any that were loosened during shipping.
4. Check the upper main roll assembly by using the handwheel to raise and lower the roll. It should move smoothly.
5. Set the nip. (See *Section 4: Maintenance and Troubleshooting* for the procedure.)
6. Verify that both sensors are clean and have an uninterrupted view of the rolls.



**WARNING**

**ALWAYS CHECK THE SENSORS PRIOR TO OPERATION! The sensors must be clean and have free view of the roll to maintain proper roll operating temperatures. The rolls can overheat and cause a fire or seriously damage the laminator.**

7. Plug the laminator into an approved socket or have a certified electrician wire the laminator directly to a power source.  
The laminator requires 30A single phase service and a power receptacle that accepts a 30A 250V NEMA L6-30P plug or, in Europe, 3 phase, 240/400 VAC with 20A per phase. See Figure 2-6 for power cord connection options.
8. Verify that the photoelectric eye is working properly. (See the procedure below.)
9. Replace both cabinet covers.

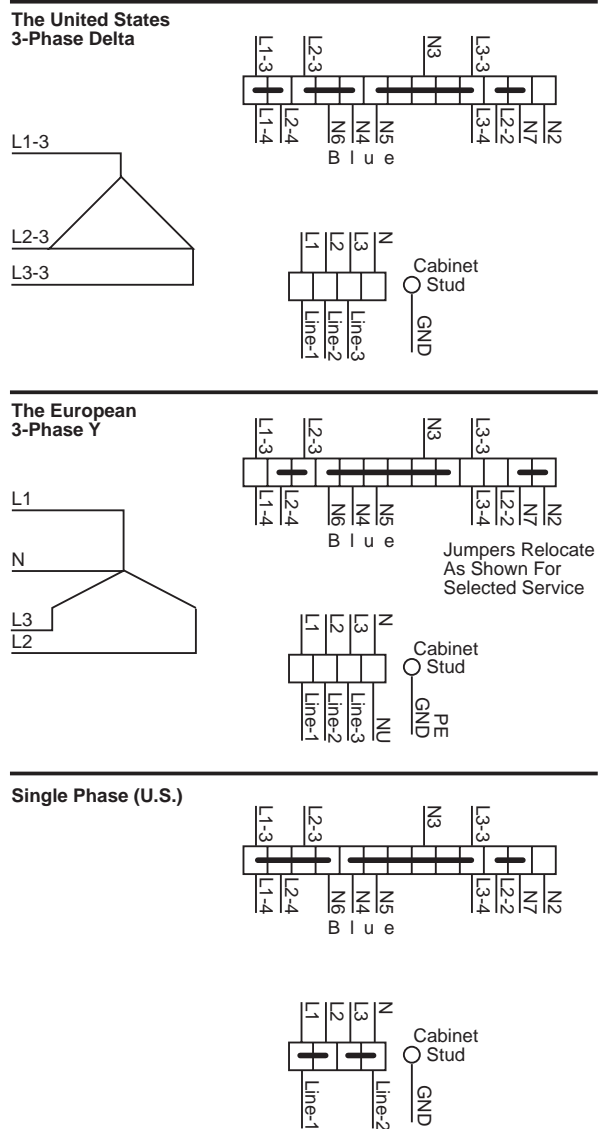

Figure 2-6: Power Cord Connection

## Startup

The first time the laminator is started and every time it is serviced you should use the following checklist to confirm that the unit is operating properly and that all safety mechanisms are functioning.

### Startup Checklist

Start the laminator and go through the following checklist.

- Are the emergency stop buttons working?  
Push down on one of the emergency stop buttons. The laminator should stop. Pull up on the button. The laminator should resume operation. Always check both buttons.



#### WARNING

**Never operate the laminator unless both of the emergency stop buttons are functioning properly. You can be crushed or burned.**

- Is the photoelectric eye system working?  
With the laminator running, place an object approximately the size of your hand just in front of the nip to confirm that the photoelectric eye system is functioning. The rolls should stop. Move the object away from the nip. The laminator should resume operation.



#### WARNING

**Never operate the laminator unless the photoelectric eye system is functioning properly. You can be crushed or burned.**

- Is the motor functioning?  
Test the motor at various speeds ranging from 0-18. At 0 the rolls should stop turning. Run the motor in both forward and reverse.
- Are the heaters working?  
Verify that the top heater controller heats the top roll and the bottom heater controller heats the bottom roll.

- Is the footswitch operating?  
Test the footswitch for both forward and reverse operation. Verify that the footswitch overrides the photoelectric eye by pressing the footswitch and pushing an object as large as your hand into the nip area.

Once you have completed the startup checklist you can safely run a test sample.

## Section 3 : Operation

### Safety

GBC Pro-Tech laminators are powerful machines that are designed to mount, laminate and encapsulate. The forces required to accomplish these tasks can vary from negligible to very large.

The spring system used to provide downward pressure on the top roll is capable of producing forces greater than 1000 pounds (454kg). This force is applied to any object presented in the opening (called the nip) between the two rolls.

In addition, the laminating rolls of the F-36 Series II can reach temperatures of over 200°F (100°C). At these temperatures there is a danger of a severe burn if the rolls are touched during set-up, operation or servicing.

An important feature of the laminator is the photoelectric eye system that stops the machine when objects move into the nip area. Once the blocking object is removed and the light beam reestablished, the rolls resume turning. However, this system is overridden if you use the footswitch.



**WARNING**

**Use extreme caution when operating the laminator with the footswitch. The photoelectric eye system is overridden, and your fingers can get caught in the nip. You can be crushed or burned.**

The F-36 Series II Laminator has a steel cabinet that is bolted closed to isolate the electrical and drive system components for the safety of the operator. Only a qualified service technician should open these cabinets.

The laminator is equipped with two emergency stop buttons located on the top of either side of the laminator. Either of these, if engaged, stops the laminator. To continue operation both emergency stop buttons must be in the up position.

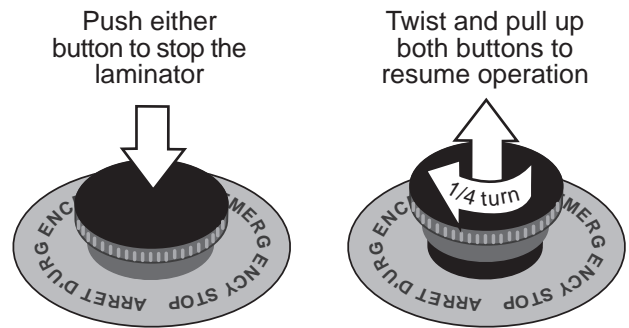

*Figure 3-1: Using the Emergency Stop Buttons*

Despite the safety features built into the F-36 Series II Laminator, extreme caution must be used when operating or servicing the unit.

**Operator Controls**

The operator controls for the F-36 Series II Laminator are located on the front of the unit, to the right of the operator position. The names and functions of these controls are as follows:

**Front Control Panel**

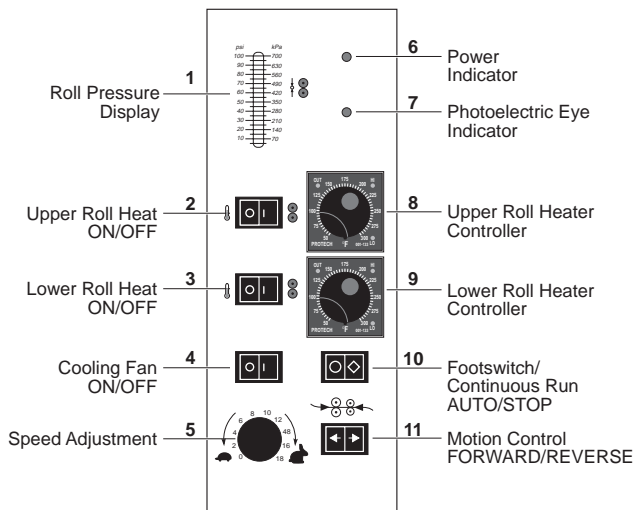

Figure 3-2: Front Control Panel

- 1. ROLL PRESSURE DISPLAY** – Displays the percentage of pressure pushing the main roll down.
- 2. UPPER ROLL HEAT ON/OFF** – Turns the heater controller for the upper main roll on or off.
- 3. LOWER ROLL HEAT ON/OFF** – Turns the heater controller for the lower main roll on or off.
- 4. COOLING FANS ON/OFF** – Turns the cooling fans on or off and turns the vacuum table fans on or off, when a vacuum table option is installed.
- 5. SPEED ADJUSTMENT** – Adjusts the speed of the machine from zero to the maximum as the control is turned clockwise.
- 6. POWER INDICATOR** – Indicates when the main power is being applied to the machine.
- 7. PHOTOELECTRIC EYE INDICATOR** – Indicates when something enters the main roll nip. The main rolls stop rotating when this lamp lights. Removal of the object blocking the photoelectric eye automatically resets the machine; the light goes out and the main rolls begin to rotate again.

- 8. UPPER ROLL HEATER CONTROLLER** – Provides a readout of the temperature of the upper roll and the set-point for the desired temperature.
- 9. LOWER ROLL HEATER CONTROLLER** – Provides a readout of the temperature of the lower roll and the set-point for the desired temperature.

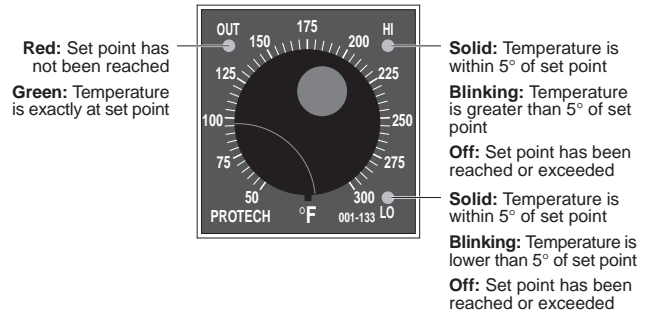

Figure 3-3: Heater Controller

- 10. FOOT SWITCH/CONTINUOUS RUN AUTO/STOP** - Changes control of the machine drive from a foot switch to continuous run.
- 11. MOTION CONTROL FORWARD/REVERSE** - Controls the direction of the drive system, forward, reverse, or stop.



**WARNING**

**Use extreme caution when operating the laminator with the footswitch. The photoelectric eye system is overridden and your fingers can get caught in the nip. You can be crushed or burned.**

## Setup

Setup of the F-36 Series II Laminator is quick and straightforward when instructions are followed exactly.

To adjust the nip, please see *Section 4: Maintenance and Troubleshooting*.

## Laminator Roll Pressure

Use only the minimum amount of roll pressure needed to accomplish the task. While higher pressure can make the adhesive bond faster, excess pressure can damage the rolls. Wrinkles and bubbles have causes that generally cannot be cured by applying more pressure.



**CAUTION**

**Excess pressure can damage the laminating rolls. Minimum laminator roll pressure is consistent with good results.**

A typical roll pressure for soft substrates such as Foam-core or Orca Board is 1/4 revolution of the laminating roll crank.

A typical roll pressure for hard substrates is 1/2 revolution of the laminating roll crank.

A typical roll pressure for encapsulation is 1/2 revolution of the laminating roll crank.

## Loading the Film

Film is loaded on the appropriate unwinds. Loading and aligning the film are discussed later in this section. For applications such as encapsulation, film is fed from both the top and bottom feed unwinds.

The process of loading and aligning film is the same for both the top and the bottom unwinds. There are two important points to remember when loading film:

1. The adhesive side of the film must be oriented away (on the outside) from the laminating roll. Otherwise it will immediately bond to the roll, creating a major clean-up project.

Films have a shiny side and a dull side. The dull side is the one with the adhesive. The dull side should **ALWAYS** face outward from the laminating roll.



**CAUTION**

**Always mount the film so that the adhesive side faces outward from the laminating roll. This prevents hours of roll cleaning.**

2. The film must be centered on the unwind for best performance. This is vital when two films are fed together. If the two films are not aligned, feed problems, wrinkles and other assorted troubles will occur.



**CAUTION**

**Carefully align the two films being fed into the nip. If not, you will obtain poor results.**

## Positioning the Film

The following procedure is applicable to both the top and bottom feed unwinds.

1. Secure the braking film mount arm so as to center the film between the side cabinets.
2. Loosen the core support film mount arm and slide it to the drive side of the machine.
3. Install the laminating film onto the braking mount arm and slide the core support arm over to support the laminating film's end.
4. Secure the support arm.

**Heating**

Use the following instructions when heating one or both of the laminating rolls. The procedure is the same for the top and bottom heaters.

1. Set the heater switch to **ON**.
2. Adjust the temperature controller for the desired operating temperature using the temperature controller dial adjustment.
3. When heating the rolls, keep the top roll down and turning at a moderate speed to prevent uneven heating.
4. The temperature controllers have LED (light emitting diode) readouts on the rotary dial to indicate the status of the heating system. See Figure 3-5 to learn about the readouts.

**Note**

*In the change over from hot to pressure-sensitive materials, it is not necessary to return the laminator to full cold. With the rolls slightly heated (115 °F), cold films do not exhibit the phenomenon of silvering.*

**Paper Tips**

1. Always cut the leading edge of a print straight so it can be fed perpendicular to the laminating rolls.
2. Ink-Jet prints done on high gloss paper might not bond or might experience bubbles (called puddling). To solve this problem, raise the heat setting of the laminator by approximately 20 °F and increase the motor speed by one third.

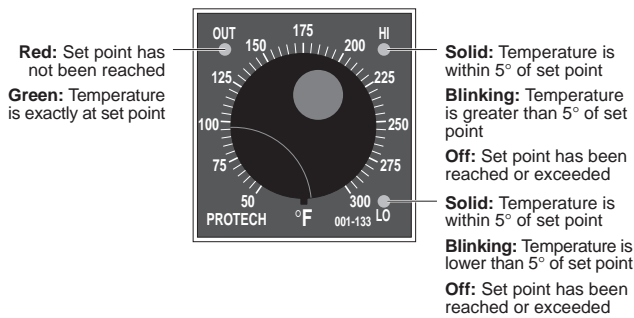

Figure 3-4: Heater Controller

5. It will take approximately 15 minutes for the laminating roll(s) to reach operating temperature. When the preset operating temperature has been reached, the machine is ready to use.

**Cooling**

The following procedure is the fastest way to cool the machine. Natural cooling can also be used.

1. Set the heater switches to **OFF**.
2. Leave the cooling system **ON**.
3. Lower the upper main roll until the laminating rolls are touching.
4. Set the Forward/Reverse switch to **FWD**.
5. Set the speed control to 2.
6. Let the machine run until the laminating rolls return to room temperature.

## Process Control Charts

Process control charts allow you to record the way you thread film through the machine's rolls and idlers (called webbing) and the control settings for each product and process. Process control charts are an excellent tool for training new operators. They provide a "road map" for correct machine setup and operation.

This section contains a blank process control chart and diagram for the F-36 Series II as well as completed charts for the basic operations of the laminator.

GBC Pro-Tech laminators respond in a very accurate and repeatable manner. The charts provide a way to set up each time, every time for repeatable performance by assuring that all controls are set to optimum.

The process control charts should be kept in this manual or in a book close to the laminator. Use the machine to encapsulate the popular charts so they can withstand food and coffee spills and so they are always available for ready reference.

### NOTE

*When trying new products and processes, remember that GBC Pro-Tech's customer service representatives are only a phone call away. In North America, call 1-800-236-8843.*

The completed process control charts included in this section are based on Falcon Film, Falcon Board, and typical prints.

## Mounting and Laminating (One Pass)

### Setup and Procedure

1. Adjust the machine settings as shown in process chart 3-2.



### WARNING

**Do not operate the laminator without the infeed table installed on the machine.**

2. Load the film onto the upper unwind assembly.

3. Insert Orca board, adhesive side down, in between the rolls. Lower them until they contact with the board. Turn the crank another 1/4 of a turn. Set the machine to reverse and remove the board by activating the motor. Do not adjust the roll crank after setting the nip. Reset the machine to forward operation.
4. Web the film by wrapping it around the upper film idler and draping it over the upper main roll. Have about six inches laying on the infeed table.
5. With a leader board of the same thickness as the mounting board, (make sure the leader board is also as wide as the film being used) press the footswitch and insert the leader board into the nip, square to the rolls. Thin input from the film should lay flat on the upper main roll. Stop feeding once the back edge of the board is one inch from the nip.
6. Lay the image onto the adhesive side of the Falcon Board. Tacking the image down with a tacking iron at this point is sometimes helpful.
7. Push the Falcon board and image up against the leader board and press the footswitch. Be sure to maintain paper tension throughout this procedure.
8. Once the board is through the nip and it no longer continues to feed, disengage the footswitch and raise the main roll. With a knife, cut the laminate on the infeed side. Pull the mounted image through the pull rolls. Do this quickly so as to eliminate the possibility of getting adhesive on the machine.

### NOTE

*You can run more than one image and board during a run of this process. Feed one board after another, until complete. Make sure that the edge of the board being fed into the nip is pushed up against the rear edge of the board already in the nip area.*

## Mounting Only

This process varies only slightly from the One Pass Mount and Laminate process.

### Setup and Procedure

1. Adjust the machine settings as shown in process chart 3-3.
2. Insert Falcon Board, adhesive side down, into the nip. Lower the upper main roll until it contacts, and then turn it another 1/4 turn. Press the footswitch to remove the board from the nip.
3. Lay the image onto the adhesive side of the Falcon Board. Tacking the image down with a tacking iron at this point is sometimes helpful.
4. Press the footswitch and carefully insert the board and image into the nip. Be sure to keep it perpendicular to the laminating rolls and maintain paper tension throughout the process.

#### Note

*Some images will release toner or ink to the upper laminating rolls. If this happens, clean immediately with alcohol. To prevent this problem, a sheet of paper can be used to cover the image during the mounting process.*

## Two-Pass Mount and Laminate (Cold Overlamine)

For this process, the image is first encapsulated and then mounted.

### Setup and Procedure, Pass 1

1. Adjust the machine settings as shown in process chart 3-4a and remove the infeed table.
2. Web up the overlamine by bringing it around the upper film idler and up to the release paper rewind. Tape the film to the rewind and give it one full wrap around the rewind tube. Be sure to check the process control chart to ensure correct web up.
3. With a single edge razor, cut across the film on the rewind tube, being sure not to cut through the release liner or the rolls.



#### WARNING

**Use extreme caution when using the single edge razor not to damage the rolls or cut yourself.**

4. Peel the film back and drape it over the upper main roll. To get enough material to do this, it may be necessary to turn the rewind tube by hand.
5. Pull the mount film straight up from the lower unwind position. Tack it to the laminate. Be careful not to stick the film or mount adhesive to the machine.
6. Insert a starter board into the nip and lower the upper main roll onto it.
7. Press the footswitch. Once the leader board is through the nip, lower the upper main roll and then rotate the crank 1/2 a turn more.
8. Reinstall the infeed table. You can operate with or without the pull rolls at this point.
9. Encapsulate the images.

**Setup and Procedure, Pass 2**

1. Adjust the machine settings as shown in process chart 3-4b.
2. Trim the print to size and trim the board to the size of the print.
3. Insert the board into the nip area and lower the main roll until it contacts. Turn the crank another 1/4 of a turn and remove the board using the foot-switch.
4. Clean the board with a tack cloth or cleaning roller.
5. Place the image face down on a flat surface and peel back the release liner on the leading edge (about two inches).
6. Lay the image on the board and align it carefully. When aligned, tack the exposed adhesive strip's center to the leading edge to the board. Work towards the edges from the center, being careful not to wrinkle the image.
7. Position the piece so that the end with the liner peeled back is facing the nip. Insert the first one inch of the board into the nip. Very carefully, wrap the print back and over the top laminating roll, maintaining good print tension throughout the mounting process. Be sure that there are no wrinkles in the nip area. Carefully peel off the liner as the board progresses through the laminator.
8. Trim the board and image to the finished size.

**Two-Pass Mount and Laminate (Hot Overlamine)**

This process is very similar to the Two Pass Mount and Laminate using cold overlamine.

**Setup and Procedure, Pass 1**

1. Adjust the machine settings as shown in process chart 3-5a and remove the infeed table.
2. Web up the hot overlamine by wrapping it around the upper film idler and draping it over the upper main roll. Drape the film only about halfway down the upper main roll.
3. Pull the mount adhesive straight up from the lower unwind position, being careful not to stick the film to the machine. Tack it to the hot overlamine.

4. Insert a starter board into the nip and lower the upper main roll onto it.
5. Press the footswitch. Once the leader board is through the nip, lower the upper main roll and then rotate the crank 1/2 a turn more.
6. Reinstall the infeed table.
7. Encapsulate the images.

**Setup and Procedure, Pass 2**

1. Adjust the machine settings as shown in process chart 3-5b.
2. Trim the print to size and trim the board to the size of the print.
3. Insert the board into the nip area and lower the main roll until it contacts. Turn the crank another 1/4 of a turn and remove the board using the foot-switch.
4. Clean the board with a tack cloth or cleaning roller.
5. Place the image face down on a flat surface and peel back the release liner on the leading edge (about two inches).
6. Lay the image on the board and align it carefully. When aligned, tack the exposed adhesive strip's center to the leading edge to the board. Work towards the edges from the center, being careful not to wrinkle the image.
7. Insert the already mounted portion of the piece into the pull roll nip. Lower the upper pull roll onto the board and image. Very carefully, wrap the print back and over the upper pull roll, maintaining good print tension throughout the mounting process. Be sure that there are no wrinkles in the nip area. Carefully peel off the liner as the board progresses through the laminator. Be careful not to hit the small lip on the fan bridge to avoid damaging the leading edge of the mounted image.
8. Trim the board and image to the finished size.

## Encapsulation

This is the most commonly performed process.

### Setup and Procedure

1. Adjust the machine settings as shown in process chart 3-6 and remove the infeed table. Be sure that, while heating the machine, the rolls are together and turning.
2. Install laminating film on the upper and lower unwinds.
3. Web up the upper laminate by wrapping it around the upper film idler and laying it over the upper main roll. Do not drape too much film. Too much can fold over and leave a line of glue on the roll, thereby affecting image quality.



**CAUTION**

**Make sure that the adhesive side of the laminate is away from the roll to prevent an extensive clean up job.**

4. Web up the lower film by wrapping it around the lower film idler and bringing it up to the upper main roll. Tack it to the upper laminating film.
5. Insert a leader board into the nip and lower the upper main roll. Press the footswitch. Once the leader board is through the nip release the footswitch. Lower the roll 1/2 a turn past the initial contact of the upper laminating roll with the lower.
6. Press the footswitch until the leader board is through the pull rolls and lower the upper pull roll. Reinstall the infeed table.
7. Encapsulate the image.

## Machine Shutdown

It is very important that the F-36 Series II laminator is shut down in proper manner. If not, the laminating rolls can be damaged or destroyed.



**CAUTION**

**Failure to follow this procedure can result in damage to the rolls.**

### Procedure

1. Turn off the main power to the machine.
2. Raise the main laminating roll at least one inch.
3. Put the output roll into the upright position.



**CAUTION**

**The laminating and output rolls must always be in the up position when the machine is not in use.**

## PROCESS CONTROL CHART

MATERIALS			
Upper Media		Image Media	
Lower Media		Mounting Substrate	
LAMINATOR SETTINGS			
Top Heater Status		Drive Mode	
Bottom Heater Status		Pull Roll Position	
Speed		Output Cooling	
Drive Direction		Main Roll Setting	

## PROCESS CONTROL DIAGRAM

Identification Diagram

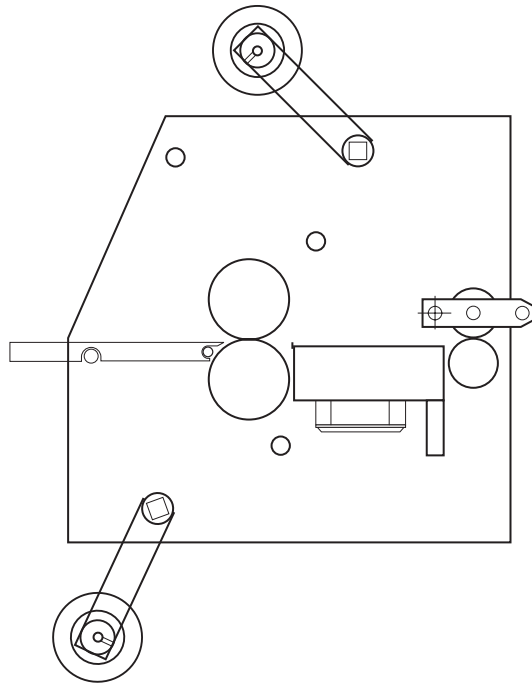

Notes

---



---



---

# PROCESS CONTROL CHART 3-2

## One-Pass Mounting and Laminating

MATERIALS			
Upper Media	3 mil gloss	Image Media	Bond Paper
Lower Media	N/A	Mounting Substrate	Falcon Board
LAMINATOR SETTINGS			
Top Heater Status	ON @ 240 °F (115 °C)	Drive Mode	Manual (Footswitch)
Bottom Heater Status	OFF	Pull Roll Position	UP
Speed	1-2 ft/min	Output Cooling	OFF
Drive Direction	FWD	Main Roll Setting	DOWN - 1/4 turn

# PROCESS CONTROL DIAGRAM 3-2

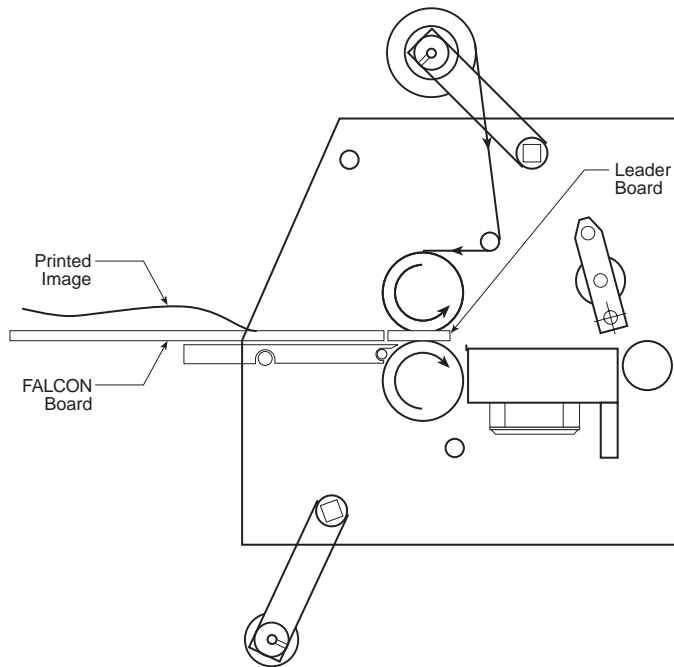

Notes

---



---



---

# PROCESS CONTROL CHART 3-3

## One-Pass Mounting

MATERIALS			
Upper Media	N/A	Image Media	Bond Paper
Lower Media	N/A	Mounting Substrate	Falcon Board
LAMINATOR SETTINGS			
Top Heater Status	ON @ 240 °F (115 °C)	Drive Mode	Manual (Footswitch)
Bottom Heater Status	OFF	Pull Roll Position	UP
Speed	2-3 ft/min	Output Cooling	OFF
Drive Direction	FWD	Main Roll Setting	DOWN - 1/4 turn

# PROCESS CONTROL DIAGRAM 3-3

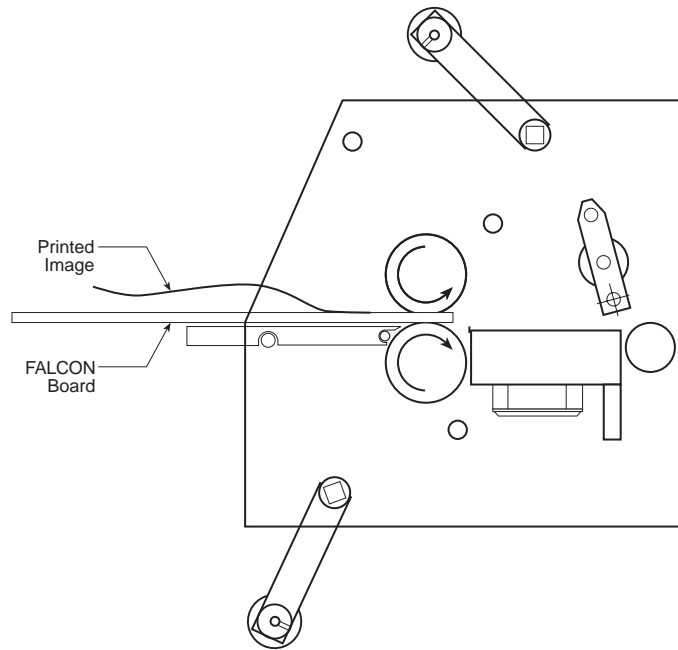

Notes

---



---



---

# PROCESS CONTROL CHART 3-4A

Two Pass Mount and Cold/Pressure Overlamine, First Pass

MATERIALS			
Upper Media	Pro-Gloss	Image Media	Bond Paper
Lower Media	Pro-Mount	Mounting Substrate	N/A
LAMINATOR SETTINGS			
Top Heater Status	ON @ 110 °F (43 °C)	Drive Mode	Manual or Auto
Bottom Heater Status	OFF	Pull Roll Position	UP or DOWN
Speed	4-6 ft/min	Output Cooling	OFF
Drive Direction	FWD	Main Roll Setting	DOWN - 1/2 turn

# PROCESS CONTROL DIAGRAM 3-4A

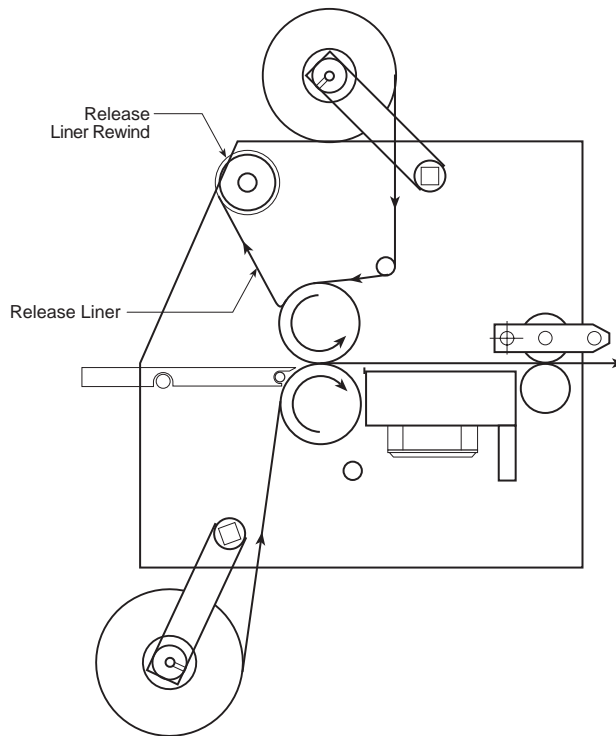

Notes

---



---



---

## PROCESS CONTROL CHART 3-4B

Two Pass Mount and Cold/Pressure Overlamine, Second Pass

MATERIALS			
Upper Media	N/A	Image Media	N/A
Lower Media	N/A	Mounting Substrate	Foam Core
LAMINATOR SETTINGS			
Top Heater Status	OFF	Drive Mode	Manual (Footswitch)
Bottom Heater Status	OFF	Pull Roll Position	UP
Speed	2-6 ft/min	Output Cooling	OFF
Drive Direction	FWD	Main Roll Setting	DOWN - 1/4 turn

## PROCESS CONTROL DIAGRAM 3-4B

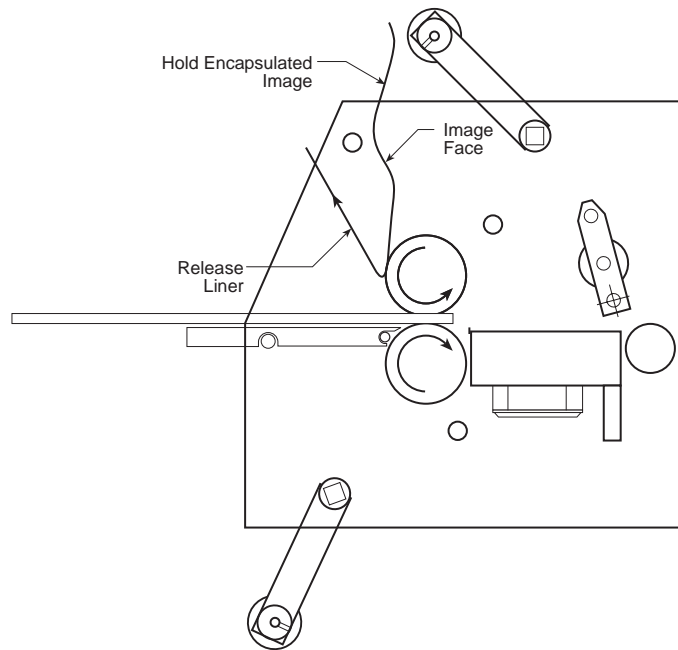

Notes

---



---



---

## PROCESS CONTROL CHART 3-5A

Two Pass Mount and Hot Overlamine, First Pass

MATERIALS			
Upper Media	3 mil Gloss	Image Media	Bond Paper
Lower Media	Pro-Mount	Mounting Substrate	N/A
LAMINATOR SETTINGS			
Top Heater Status	ON @ 230 °F (110 °C)	Drive Mode	Manual or Auto
Bottom Heater Status	OFF	Pull Roll Position	DOWN
Speed	3-4 ft/min	Output Cooling	OFF
Drive Direction	FWD	Main Roll Setting	DOWN - 1/2 turn

## PROCESS CONTROL DIAGRAM 3-5A

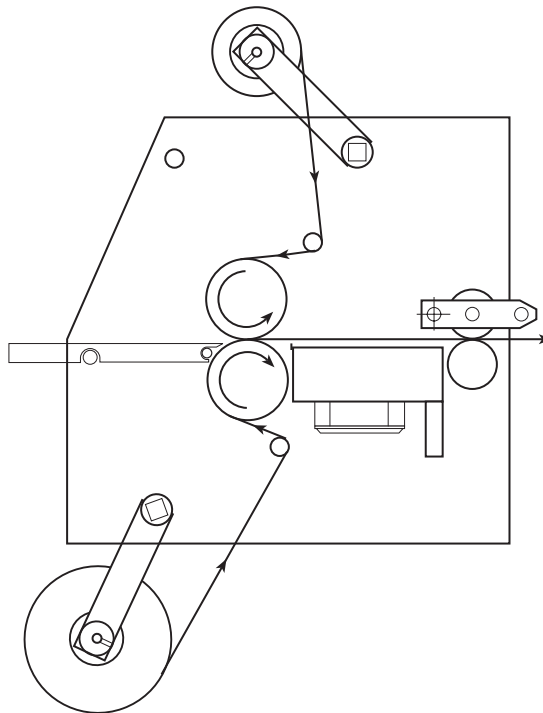

Notes

---



---



---

## PROCESS CONTROL CHART 3-5B

Two Pass Mount and Hot Overlamine, Second Pass

MATERIALS			
Upper Media	N/A	Image Media	N/A
Lower Media	N/A	Mounting Substrate	Foam Core
LAMINATOR SETTINGS			
Top Heater Status	OFF	Drive Mode	Manual (Footswitch)
Bottom Heater Status	OFF	Pull Roll Position	DOWN
Speed	2-3 ft/min	Output Cooling	OFF
Drive Direction	REV	Main Roll Setting	UP

## PROCESS CONTROL DIAGRAM 3-5B

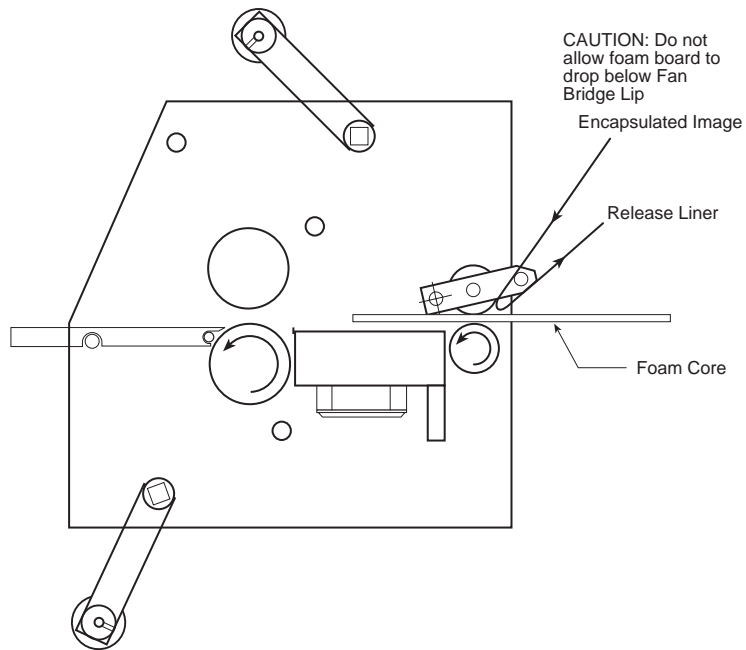

Notes

---



---



---

# PROCESS CONTROL CHART 3-6

## Encapsulation

MATERIALS			
Upper Media	3 mil Gloss	Image Media	Bond Paper
Lower Media	3 mil Gloss	Mounting Substrate	N/A
LAMINATOR SETTINGS			
Top Heater Status	ON @ 230 °F (110 °C)	Drive Mode	Manual or Auto
Bottom Heater Status	ON @ 230 °F (110 °C)	Pull Roll Position	DOWN
Speed	3-6 ft/min	Output Cooling	OFF
Drive Direction	FWD	Main Roll Setting	DOWN - 1/4 turn

# PROCESS CONTROL DIAGRAM 3-6

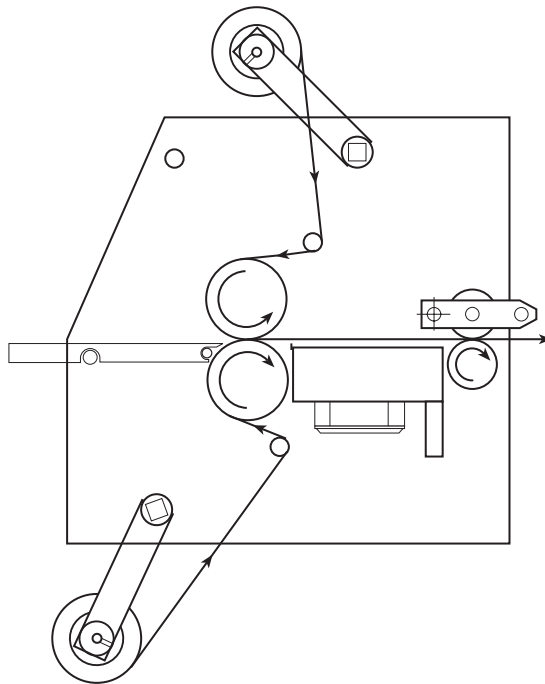

Notes

---



---



---

## Section 4 : Maintenance and Troubleshooting

Performing regular maintenance on the F-36 Series II Laminator is critical to the proper operation of the machine. A maintenance schedule and a section of procedures for disassembling and reassembling the serviceable areas of the laminator are included in this section.

Table 4-1: Maintenance Schedule

Daily	<ul style="list-style-type: none"> <li>• Clean/adjust the thermocouples</li> <li>• Clean the rolls</li> <li>• Inspect the electrical cord for damage</li> <li>• Inspect the footswitch cord for damage</li> </ul>
Monthly	<ul style="list-style-type: none"> <li>• Adjust the nip</li> <li>• Check the chain tension</li> <li>• Inspect the area around the laminator for possible hazards (dust buildup, combustible items stored too close, etc.)</li> </ul>
Every Six Months	<ul style="list-style-type: none"> <li>• Lubricate the grease fittings and chain</li> <li>• Check wire termination tightness</li> </ul>

### Thermocouple Positioning and Cleaning

One of the most crucial adjustments to the F-36 Series II Laminator is positioning the thermocouples and making sure they are clean. There are two thermocouples that control the temperature of the main rolls. If a thermocouple loses contact with its roll, the roll can overheat and be seriously damaged or can even start a fire. Therefore, it is absolutely critical that both thermocouples be clean and positioned properly before operating the laminator and it should become second nature to check their condition prior to applying power to the laminator.

#### Tools required:

- 1/8" hex wrench
- 80% isopropyl alcohol
- 100% lint free paper or cotton terry cloth



**CAUTION**

**ALWAYS CHECK THE POSITION AND CONDITION OF THE THERMOCOUPLES PRIOR TO OPERATION! The thermal junction of the thermocouples MUST make contact with the laminating rolls to maintain proper roll operating temperatures. The thermocouples must also be free of adhesive and dirt. The rolls can overheat and cause a fire or seriously damage the laminator.**



**WARNING**

**Do not attempt to adjust the position of the thermocouples if the rolls are hot. You can be seriously burned.**

#### To adjust a thermocouple:

1. Locate the thermocouple to be adjusted using the illustration in Figure 4-3.
2. Remove the two screws securing the thermocouple to the laminator using the 1/8" hex wrench and take the thermocouple out.
3. Inspect the thermocouple. If there is any adhesive or dirt on the thermocouple gently clean it off with 80% isopropyl alcohol and a cotton terry cloth.
4. Grasp the aluminum base of the thermocouple on either side of the rivets to provide support as shown in Figure 4-1. Using your fingers, gently bend the thermocouple where the "guitar pick" sensor meets the aluminum base.

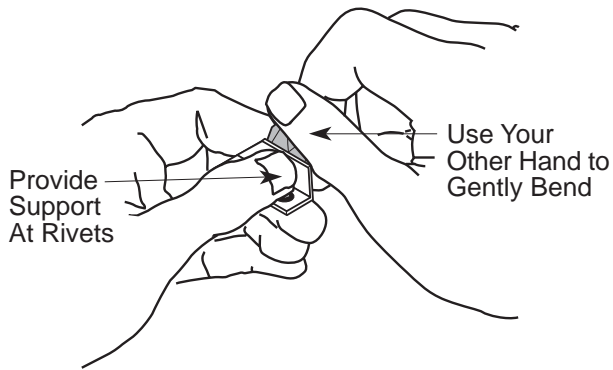

Figure 4-1: Adjusting the Thermocouple

Once installed, the critical point of the thermocouple MUST make direct contact with the roll as shown in Figure 4-2.

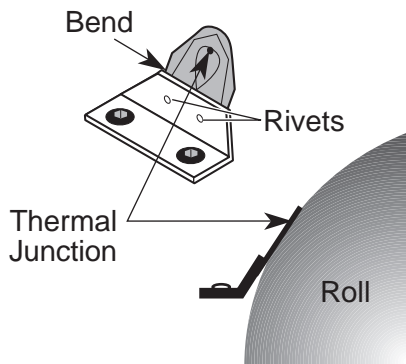

Figure 4-2: Correct Thermocouple Contact



### CAUTION

**Firmly hold the thermocouple where the “guitar pick” sensor is riveted to the aluminum base while bending. You can break the sensor off the base if you do not provide this added support.**

5. Replace the thermocouple and tighten the screws.
6. Repeat the procedure for the other thermocouple.

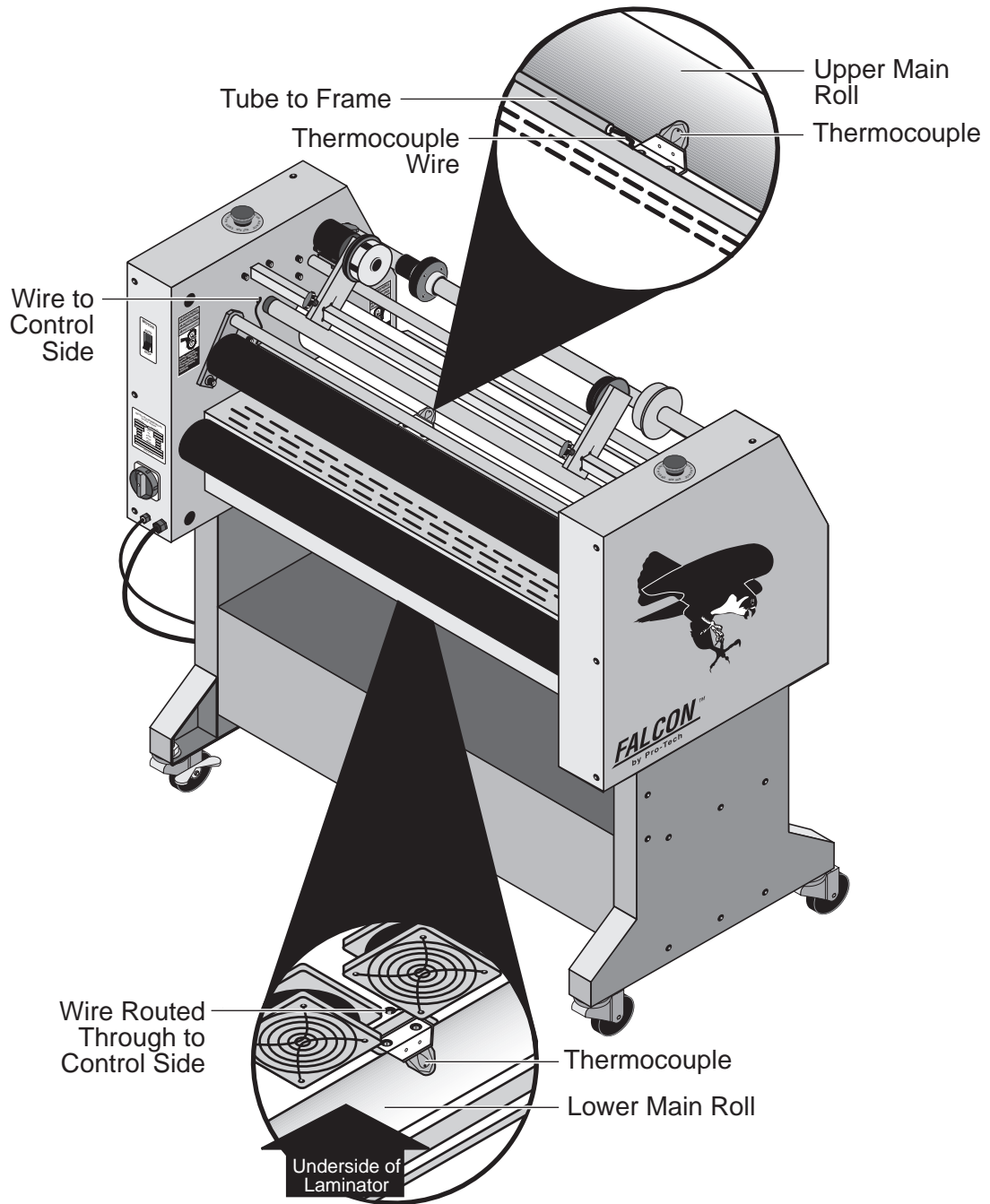

Figure 4-3: Locations of the Thermocouples

**To clean the laminator rolls:**

1. Remove the infeed table and infeed pressure plate to gain access to the rolls.



**WARNING**

**Exercise extreme caution while cleaning the laminator. You can be caught in the turning rolls and crushed or burned.**

2. While the laminator is at normal operating temperature, put on the rubber gloves and, using a rubber cement eraser, remove any heat activated adhesive from the rolls.



**CAUTION**

**If silicone adhesive contacts the upper or lower roll, remove it IMMEDIATELY using a rubber cement eraser. It can harden within an hour and ruin the roll.**



**CAUTION**

**Do NOT pick or pull heat activated adhesive off the rolls when they are cold. You can cause irreparable damage to the laminating rolls.**

**To clean beads of adhesive, dust and dirt from the rolls:**

1. Allow the laminator to cool slightly to no higher than 110°F (43°C).
2. Set the FWD/REV switch to the REV position and use the footswitch to move the rolls as you clean them. Set the Speed Control to 1.5 ft/min.
3. Clean the rolls using a moderate amount of 80% isopropyl alcohol on a cotton terry cloth.



**CAUTION**

**Use the minimum amount of pressure necessary to clean the rolls. You can destroy the silicone layer on the rolls by pressing too hard or scrubbing too long in one spot.**



**WARNING**

**Exercise care when cleaning the rolls with 80% isopropyl alcohol:**

- Use only in a well ventilated area.
- Wear rubber gloves.
- Use only on cool rolls.

**Cleaning heated rolls can ignite the fumes.**



**CAUTION**

**Use only 80% isopropyl alcohol or a rubber cement eraser to clean the laminating rolls. Harsh chemicals like toluene, acetone or MEK destroy the silicone covering of the rolls.**

4. With the laminator rolls no hotter than 110° remove dust and dirt from the silicone laminating rolls by running an adhesive-coated board through the laminator. Be sure to set the nip for the thickness of the board used.
5. Allow the laminator to cool.

**To clean the cabinet and covers:**

1. Unplug the laminator to clean the exterior.
2. Using a damp cotton terry cloth (water only), clean the exterior of the laminator.

**WARNING**

**Do not use liquid or aerosol cleaners on the laminator. Do not spill liquid of any kind on the laminator. You can be severely shocked, electrocuted or cause a fire. Use only a damp cloth for cleaning.**

**WARNING**

**Do not use compressed air to clean the machine. Blowing debris can be forced into places where it will later ignite or short electric circuits.**

**Adjusting the Nip**

The gap between the two main rolls is called the nip. The purpose of adjusting the nip is to ensure continuous contact between the laminating rolls as the media is drawn through the machine. This procedure must be done regularly.

**Tools required:**

- 1/8" hex wrench
- (2) 3/4" open end wrenches

**To adjust the nip:****CAUTION**

**The main rolls must be at room temperature to achieve a proper nip setting.**

1. Unplug the laminator and make sure it won't be plugged back in while you are performing this procedure.
2. Remove the drive and control side cabinet covers with the 1/8" hex wrench by removing the six screws holding each cover in place.
3. Using the handwheel, lower the upper main roll until there is a small gap of light between the upper and lower main rolls.
4. Loosen the jamnut on the nip adjusting bolt on each side of the laminator as shown in Figure 4-4.

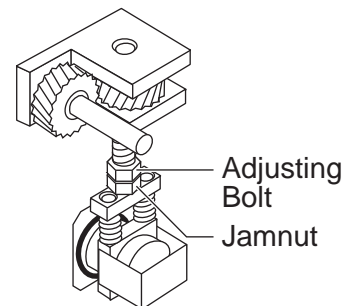

*Figure 4-4: Adjusting the Nip*

- Adjust the nip by turning the adjusting bolt using an  $\frac{3}{4}$ " open end wrench (clockwise to lower the roll end and counter clockwise to raise the roll end). Adjust the ends of the upper main roll until there is an even gap between the rolls as shown in Figure 4-5.

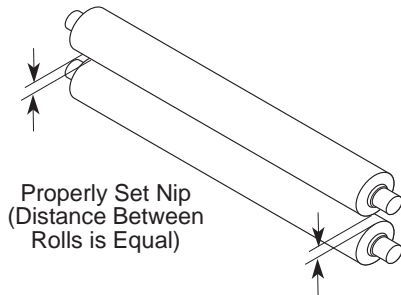

Figure 4-5: Properly Set Nip

- Hold the adjustment bolt in place while tightening the jamnut on each side of the laminator.
- Replace both cabinet covers and reconnect power to the laminator.

**Chain Tensioning**

Adjusting the chain tension on the F-36 Series II Laminator is a simple procedure that keeps the system running smoothly and maximizes the efficiency of the motor.

**Tools required:**

- $\frac{1}{8}$ " hex wrench
- $\frac{3}{16}$ " hex wrench
- Screwdriver

**To adjust the chain tension:**

- Unplug the laminator and make sure it won't be plugged back in while you are performing this procedure.
- Remove the drive side cabinet cover using the  $\frac{1}{8}$ " hex wrench by removing the six screws holding the cover in place.
- Loosen all four motor mount bolts using the  $\frac{3}{16}$ " hex wrench as shown in Figure 4-6. The motor should just move freely within the slots.

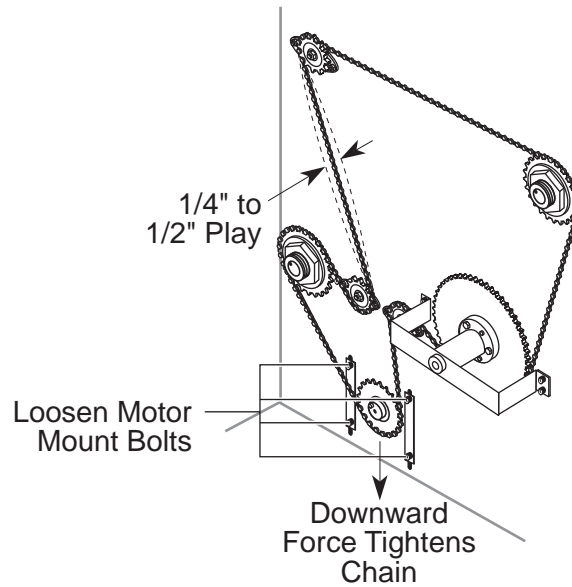

Figure 4-6: Adjusting the Chain Tension

- Using a screwdriver, apply a small amount of downward pressure on the motor by prying against the inside of the side frame until there is  $\frac{1}{4}$ " to  $\frac{1}{2}$ " play in the chain.
- Tighten the mounting bolts while maintaining the downward pressure on the motor.
- Replace the cabinet cover and reconnect power to the laminator.

**Lubrication**

**Tools required:**

- $\frac{1}{8}$ " hex wrench
- High temperature grease or lithium grease
- Grease gun

**To lubricate the laminator:**



**WARNING**

**Do not lubricate the laminator when it is hot. You can be burned.**

**WARNING**

**Unplug the laminator and lockout power while you are performing this procedure. You could be severely shocked, electrocuted, or get your fingers caught in the drive mechanisms.**

1. Remove the drive and control side cabinet covers using the  $\frac{1}{8}$ " hex wrench by removing the six screws holding each cover in place.
2. Using the grease gun, lubricate each grease fitting (shown in Figure 4-7) with one squirt of high temperature grease.

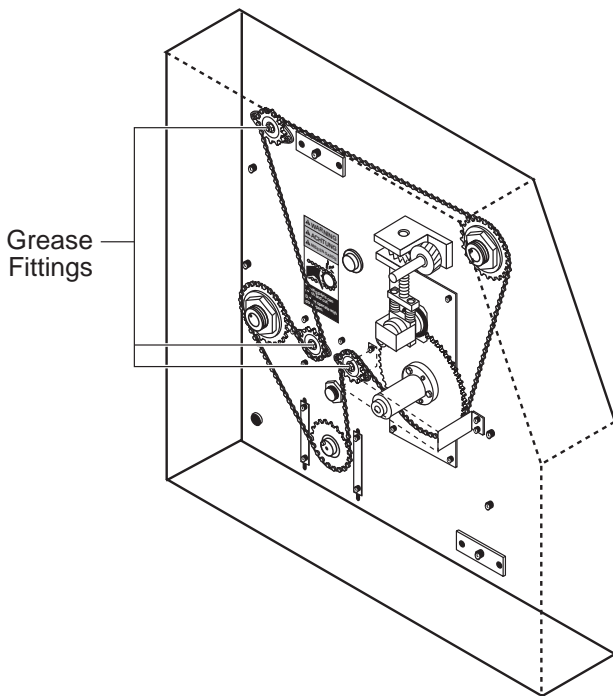

*Figure 4-7: Grease Fittings*

3. Lubricate the chain using a soft cloth and automotive oil.
4. Replace the cabinet covers and reconnect power to the laminator.

**Contacting Technical Support**

For machine parts and technical service in North America, please call: 1-800-790-7787. **Please provide serial number when calling for service.** In Europe, please call: +44 (0) 1844 202 440 or fax: +44 (0) 1844 202 441.

For film and application questions in North America, please call 1-800-236-8843. In Europe, please call: +44 (0) 1844 202 440 or fax: +44 (0) 1844 202 441.

**Output Troubleshooting Guide**

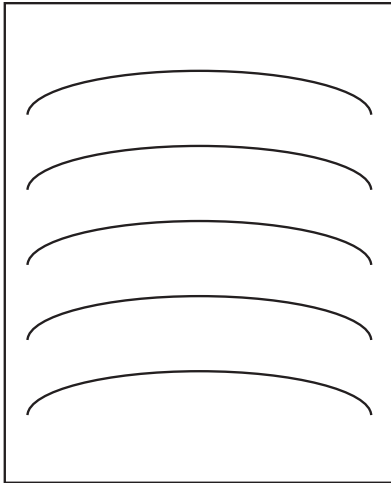

**Problem:**  
D waves in the image, not in the laminate.

- Hints:**
- Check paper tension.
  - Check relative moisture content of the paper.

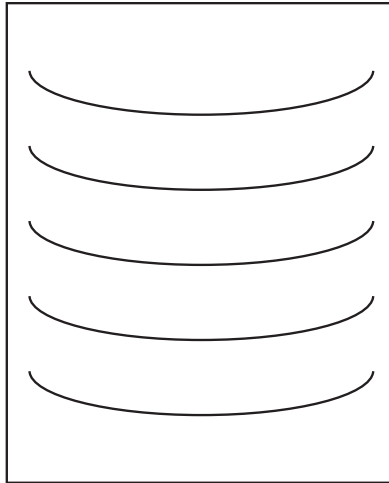

**Problem:**  
D waves in the laminate.

- Hints:**
- Increase clutch tension.
  - Check roll pressures.
  - Check nip settings.

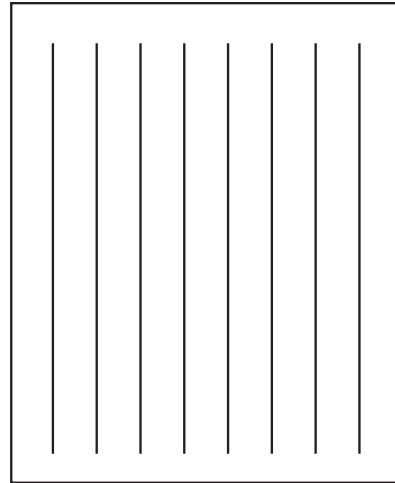

**Problem:**  
Straight waves in the output.

- Hints:**
- Decrease clutch tension.
  - Check operational settings for materials being used.

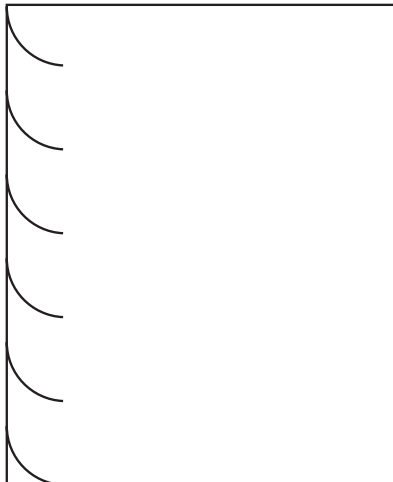

Feed  
Direction



**Problem:**  
Waves on only one side of the output.

- Hints:**
- Check nip settings.
  - Check for even paper tension.

**Other Common Problems:**

**Problem:**  
Blistering in the image.

- Hints:**
- Increase speed or lower the operating temperature.

**Problem:**  
Coiling of encapsulated images.

- Hints:**
- Balance the upper and lower unwind brake tension. Make sure main roll temperatures are the same. Adjust cooling fans.

**Problem:**  
Longitudinal waves or stuttering, jerking, or excessive noise from the drive side of the laminator.

- Hints:**
- Increase chain tension, decrease unwind brake tension.

## Section 5 : Warranty

### Limited Warranty

GBC Pro-Tech Engineering Company, Inc. warrants the equipment sold is free from defects in material and workmanship for a period of ninety days (90) **from the date of delivery** to the customer. This warranty is the only warranty made by GBC Pro-Tech and cannot be modified or amended.

**GBC Pro-Tech's sole and exclusive liability and the customer's sole and exclusive remedy under this warranty shall be, at GBC Pro-Tech's option, to repair or replace any such defective part or product. These remedies are only available if GBC Pro-Tech's examination of the product discloses to GBC Pro-Tech's satisfaction that such defects actually exist and were not caused by misuse, neglect, attempt to repair, unauthorized alteration or modification, incorrect line voltage, contaminated air supply, or by fire, accident, flood, or other hazard.**

This warranty specifically does not cover damage to the laminating rollers caused by knives, razor blades, other sharp objects, failure caused by adhesives or improper use of the machine. Warranty repair or replacement does not extend the warranty beyond the initial ninety day period from the date of delivery.



### CAUTION

**Unauthorized customer alterations will void this warranty.**

THE WARRANTY MADE HEREIN IS IN LIEU OF ALL OTHER WARRANTIES, EXPRESS OR IMPLIED, INCLUDING ANY WARRANTY OR MERCHANTABILITY OR FITNESS FOR A PARTICULAR PURPOSE. GBC PRO-TECH WILL NOT BE LIABLE FOR PROPERTY DAMAGE OR PERSONAL INJURY (UNLESS PRIMARILY CAUSED BY ITS NEGLIGENCE), LOSS OF PROFIT OR OTHER INCIDENTAL OR CONSEQUENTIAL DAMAGES ARISING OUT OF THE USE OR INABILITY TO USE THE EQUIPMENT.

### Exclusions to the Warranty

**This warranty specifically does not cover:**

1. Damage to the laminating rolls caused by knives, razor blades, other sharp objects, or failure caused by adhesives.
2. Damage to the machine caused by lifting, tilting, and/or any attempt to position the machine other than rolling on the installed casters on even surfaces.
3. Improper use of the machine.

Blank page.

**Section 6 : Specifications**

*Table 6-1: F-36 Series II Laminator Specifications*

Characteristic	Specifications
Dimensions (L x D x H)	56" x 31" x 56" (1.42 x .79 x 1.42m)
Weight	Uncrated: 300 lbs (136 kg) Crated : 500 lbs (225 kg)
Laminating Rolls	42" (1.06m) roll face with high release surface, upper and lower rolls internally heated
Laminating Opening	1.5" (3.8 cm) maximum opening controlled with infinitely variable hand crank
Laminating Material	Uses heat activated and pressure-sensitive materials 0 - 39" (99.6 cm) wide on a 3" (7.6 cm) ID core, 10" (25.4 cm) maximum diameter
Laminating Speeds	0 to 18 fmp (0 to 5.5 mpm) with variable speed, reversible action, start and stop controlled either through the instrument panel or with the footswitch
Encapsulating Features	Pull rolls and cooling fans for uniform flat cooling
Safety Features	<ul style="list-style-type: none"> <li>• Photoelectric eye system prevents laminating roll movement when hands are in the nip area</li> <li>• All electrical and moving mechanical parts are located in bolted cabinets</li> <li>• Hand crank for laminating roll movement</li> <li>• Emergency stop buttons with a reset button circuit</li> </ul>
Options	<ul style="list-style-type: none"> <li>• Unwind for rolled prints</li> <li>• Rewind for rolled prints</li> <li>• Vacuum table</li> <li>• Outfeed Slitters</li> <li>• Outfeed Table</li> </ul>
Installation Requirement	220VAC 50 or 60 Hz single phase, 30A

Blank page.

**Index****A**

Accessory pack 2-3  
Adjusting bolt 4-5, 4-6

**C**

Chain  
    Lubrication 4-7  
    Tensioning 4-6  
Clutch  
    Common problems 4-8  
Controls  
    Front control panel 3-2

**E**

Emergency stop buttons 1-1, 2-8, 3-1  
Encapsulating 6-1  
Encapsulation 3-8  
Environment 2-1

**F**

Film  
    Loading 3-3  
    Positioning 3-3  
Foot bolt 2-4, 2-5  
Footswitch 1-1, 1-2, 2-8, 3-1, 4-1, 4-4, 6-1  
FWD/REV switch 4-4

**G**

Grease fittings 4-7

**H**

Handwheel 2-6, 4-5  
Heater 2-8  
    Controller 2-8  
Heating 3-4

**I**

Infeed table 4-4  
Installation requirements 2-1, 6-1

**L**

Laminating material 6-1  
Laminating opening 6-1  
Laminating rolls 6-1  
Laminating speeds 6-1  
Lubrication 4-6

**M**

Main roll  
    Lower 4-5  
Main rolls 4-1, 4-5  
    Temperature 4-1  
Maintenance schedule 4-1  
Motor 2-8, 4-6  
Mounting and laminating (one pass) 3-5  
Mounting only 3-6

**N**

Nip 1-1, 1-2, 2-6, 2-8, 3-1, 4-1, 4-4, 4-5, 4-6, 6-1

**O**

Outfeed slitters 6-1  
Outfeed table 6-1

**P**

Paper 3-4  
Photoelectric eye 1-1, 1-2, 2-7, 2-8, 3-1  
Power requirement 2-1  
Preinstallation checklist 2-1  
Pressure  
    Laminator roll 3-3  
Process control charts 3-5

**R**

Riggers 1-3, 2-4, 2-5, 2-6

**S**

Safety features 6-1  
Safety information 1-1  
Safety labels 1-4  
Setup 3-3  
Setup procedure 2-6  
Shutdown 3-8  
Specifications  
    Dimensions 6-1  
    Encapsulating 6-1  
    Laminating material 6-1  
    Laminating opening 6-1  
    Laminating rolls 6-1  
    Laminating speeds 6-1  
    Weight 6-1

**T**

Technical support  
    Call 1-800-236-8843 4-7  
Thermocouple 4-1, 4-2, 4-3  
    Locations 4-3  
thermocouple 4-1  
Two-pass mount and laminate 3-6, 3-7

**U**

Unpacking 2-3  
    Cardboard box 2-3  
    Crate 2-5  
Upper main roll 1-3, 2-6, 4-5, 4-6  
Upper main roll assembly 2-6

**V**

Vacuum table 6-1

**W**

Warnings and cautions 1-1  
Warranty 5-1