



EAGLE 35, 65,105 Parts List

GBC IS AN ACCO BRANDS COMPANY



8.0 PARTS LIST

All parts in each illustration are keyed with an index number for reference to the respective part number, part name, and quantity in the parts list.

When ordering service parts, always include the following information:

Machine Model Number

Machine Serial Number

Part Number

Part Name

Quantity Required

Note: The Service Parts Department does not stock all hardware; to avoid delay, standard hardware shown in the parts list should be purchased locally.

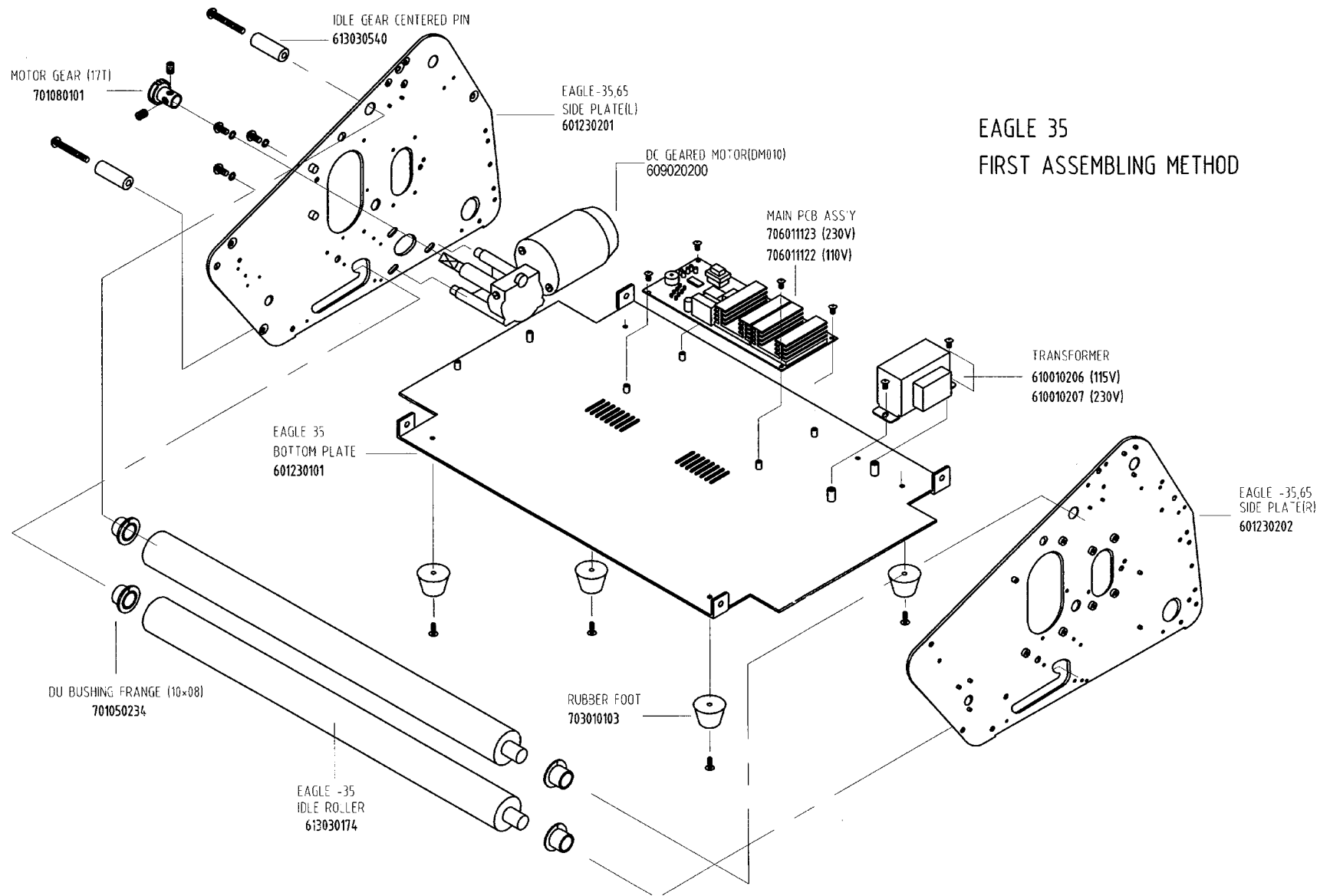

**EAGLE 35
FIRST ASSEMBLING METHOD**

EAGLE 35 SECOND ASSEMBLING METHOD

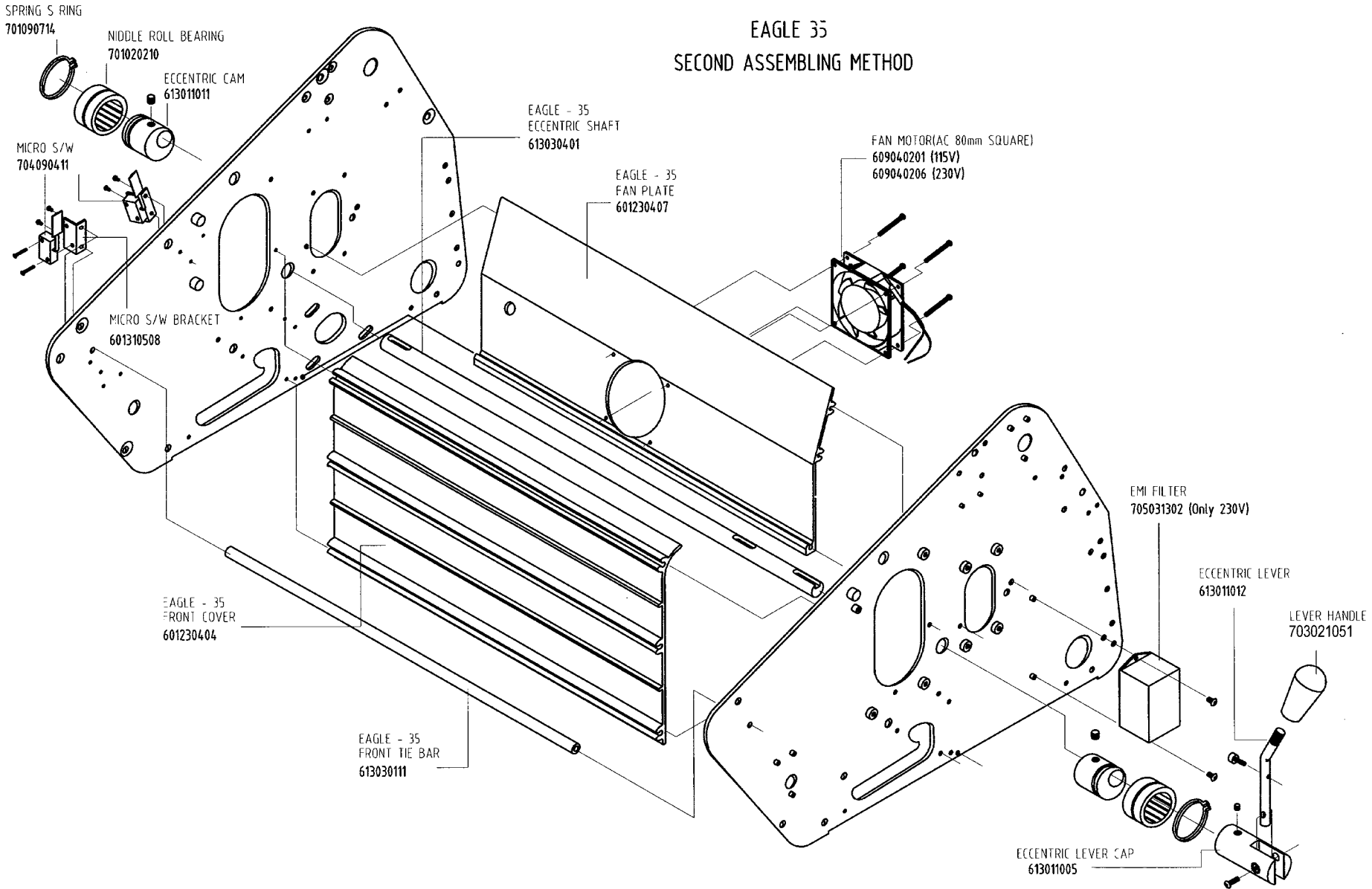

EAGLE 35 THIRD ASSEMBLING METHOD

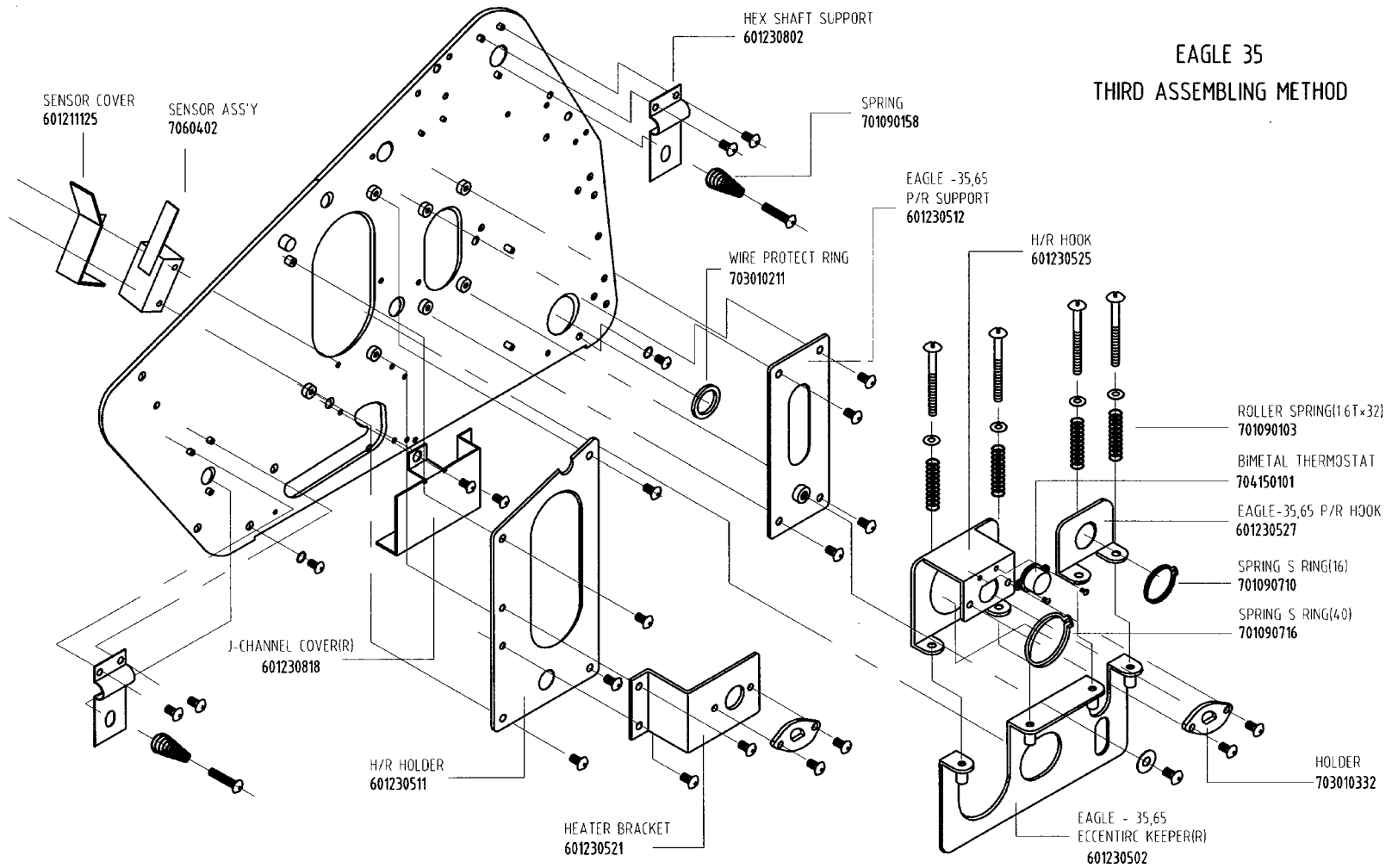

EAGLE 35 FOURTH ASSEMBLING METHOD

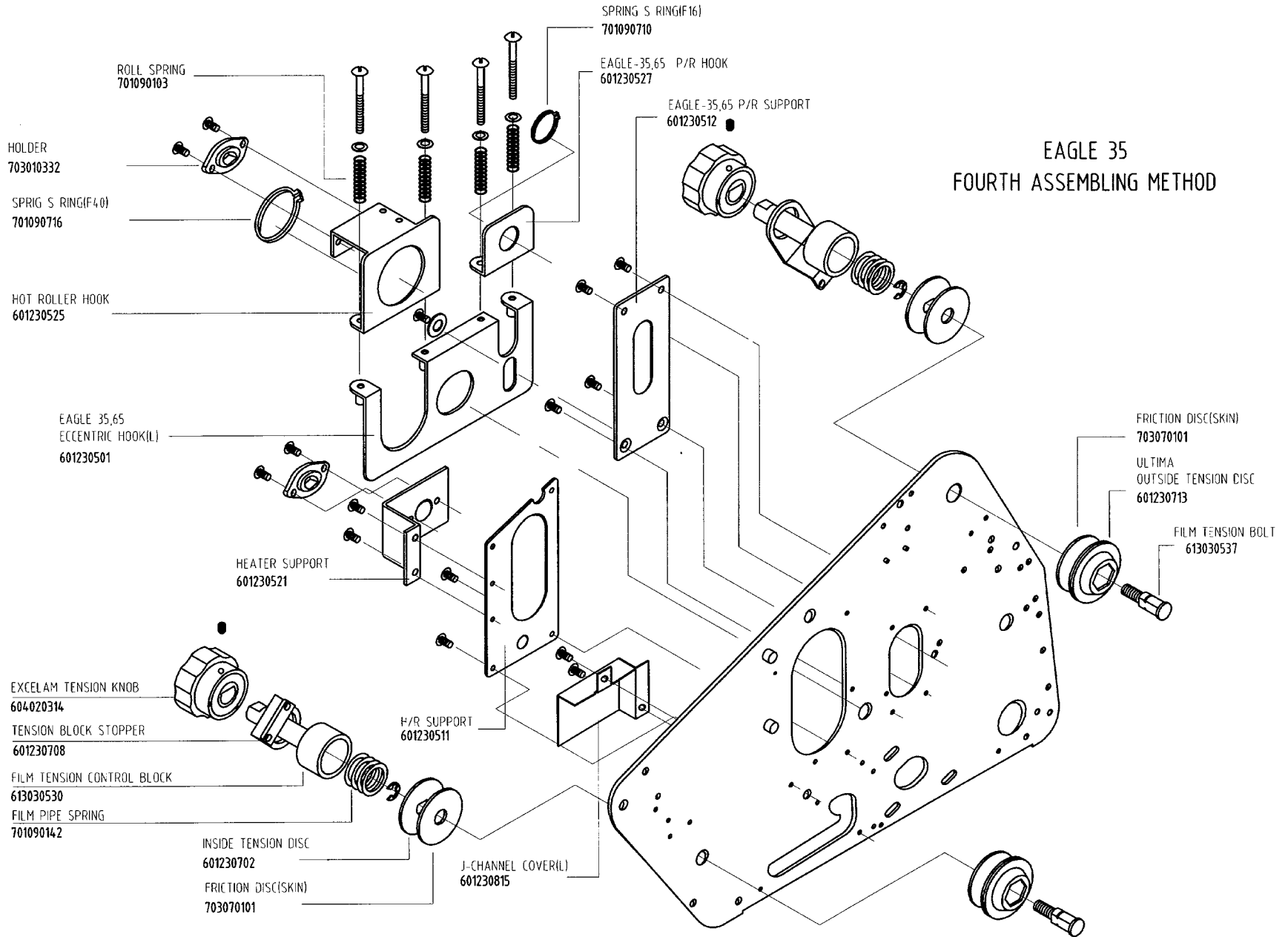

EAGLE 35 FIFTH ASSEMBLING METHOD

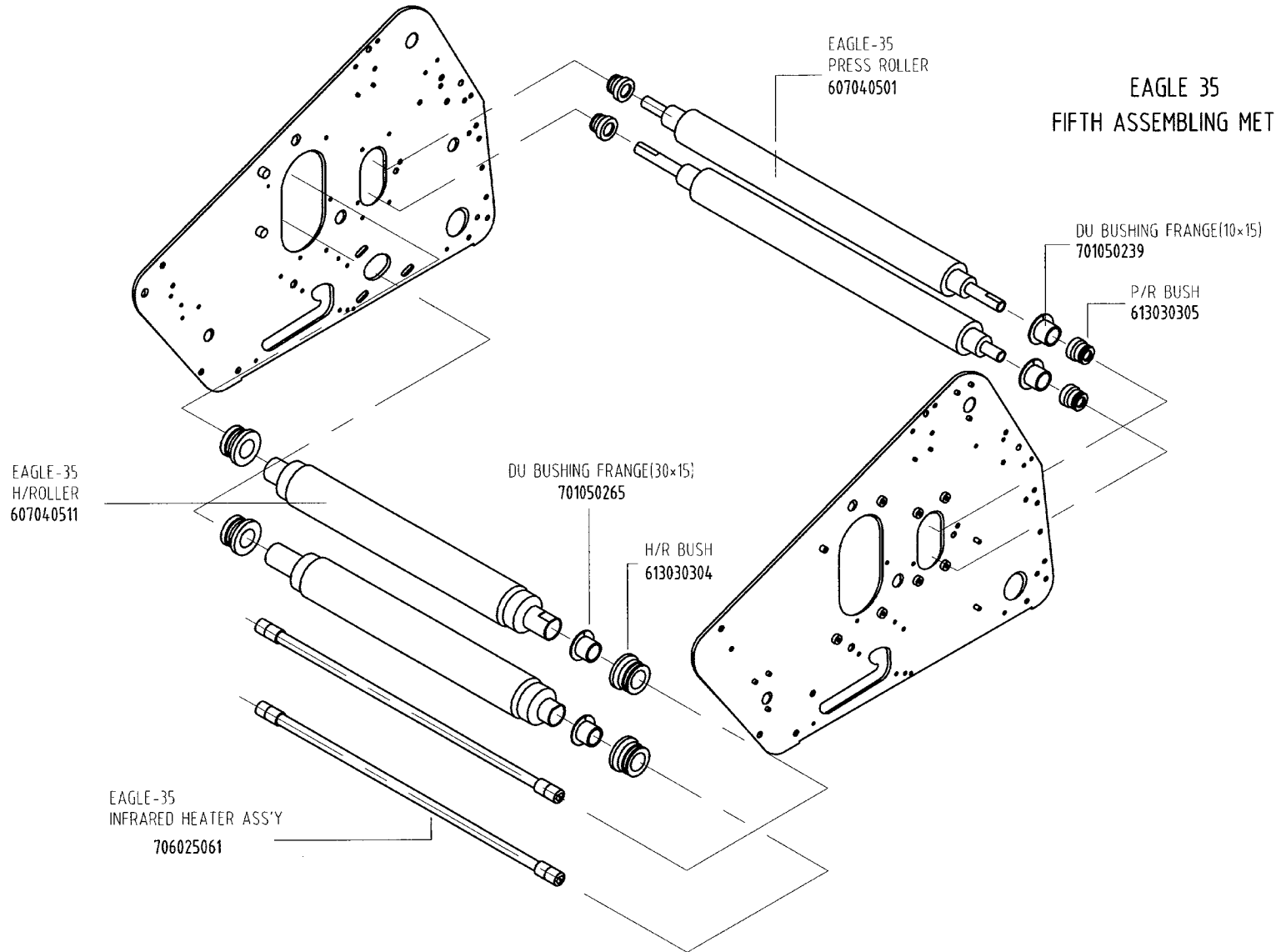

EAGLE 35 SIXTH ASSEMBLING METHOD

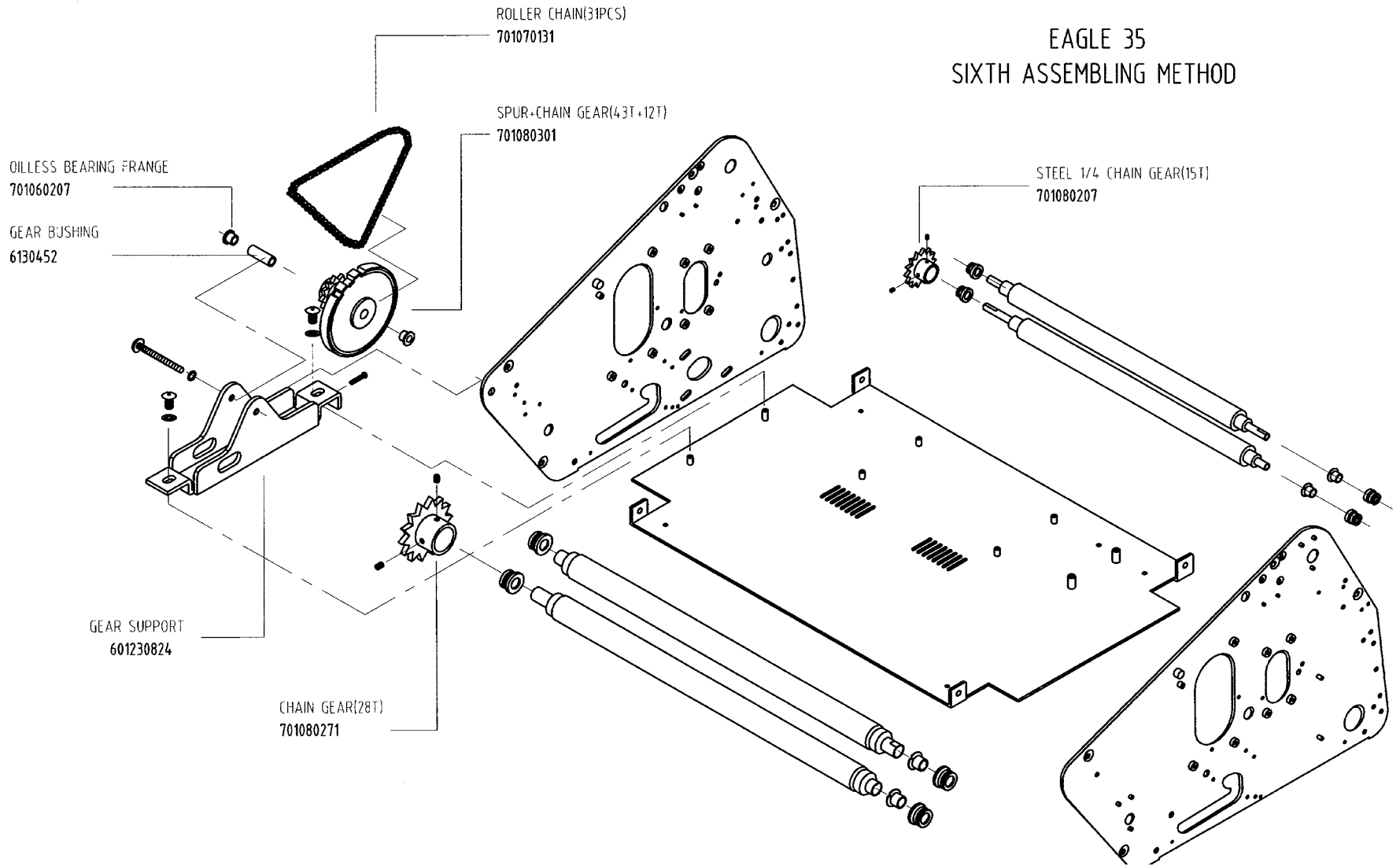

EAGLE 35 SEVENTH ASSEMBLING METHOD

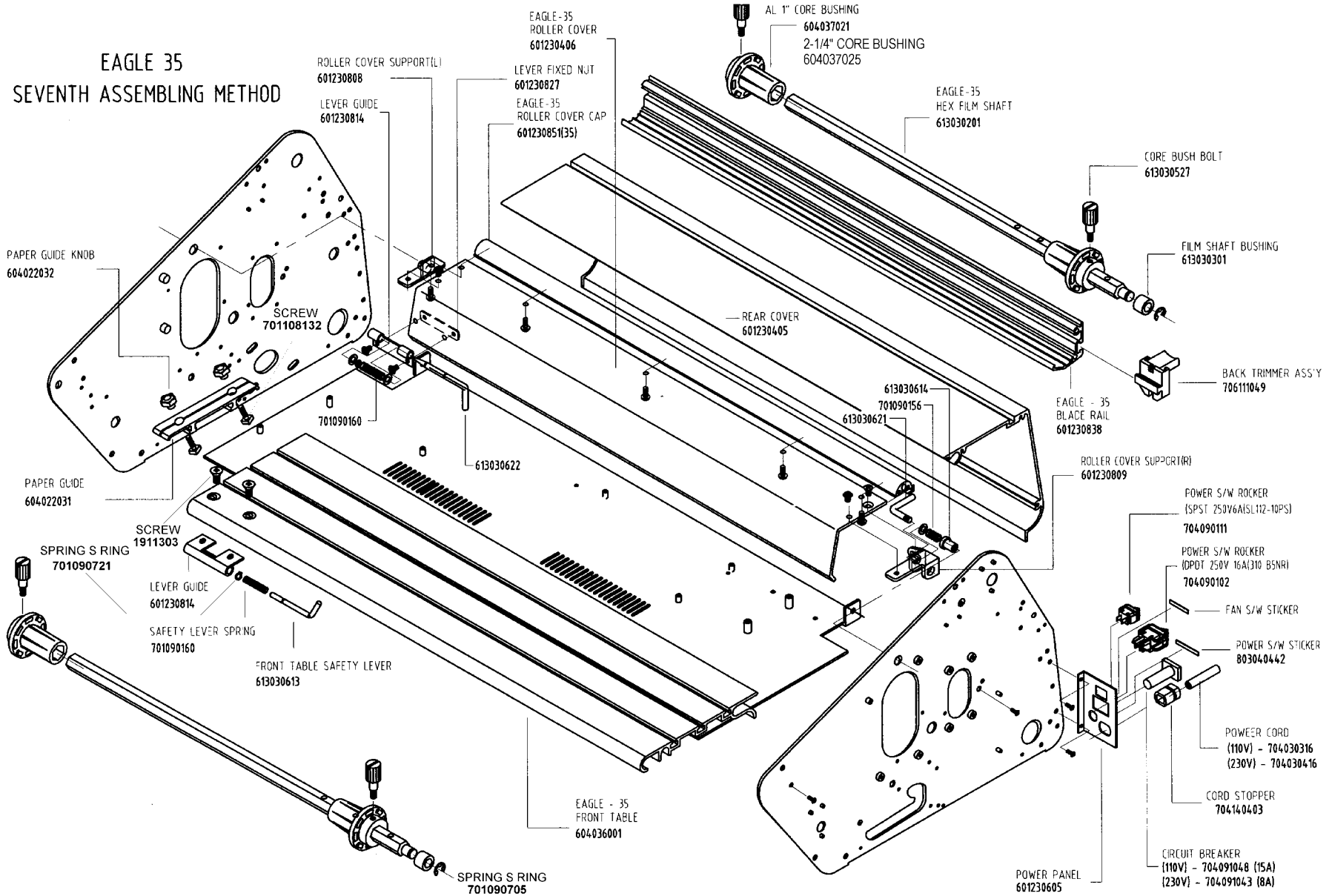

EAGLE 35 EIGHTH ASSEMBLING METHOD

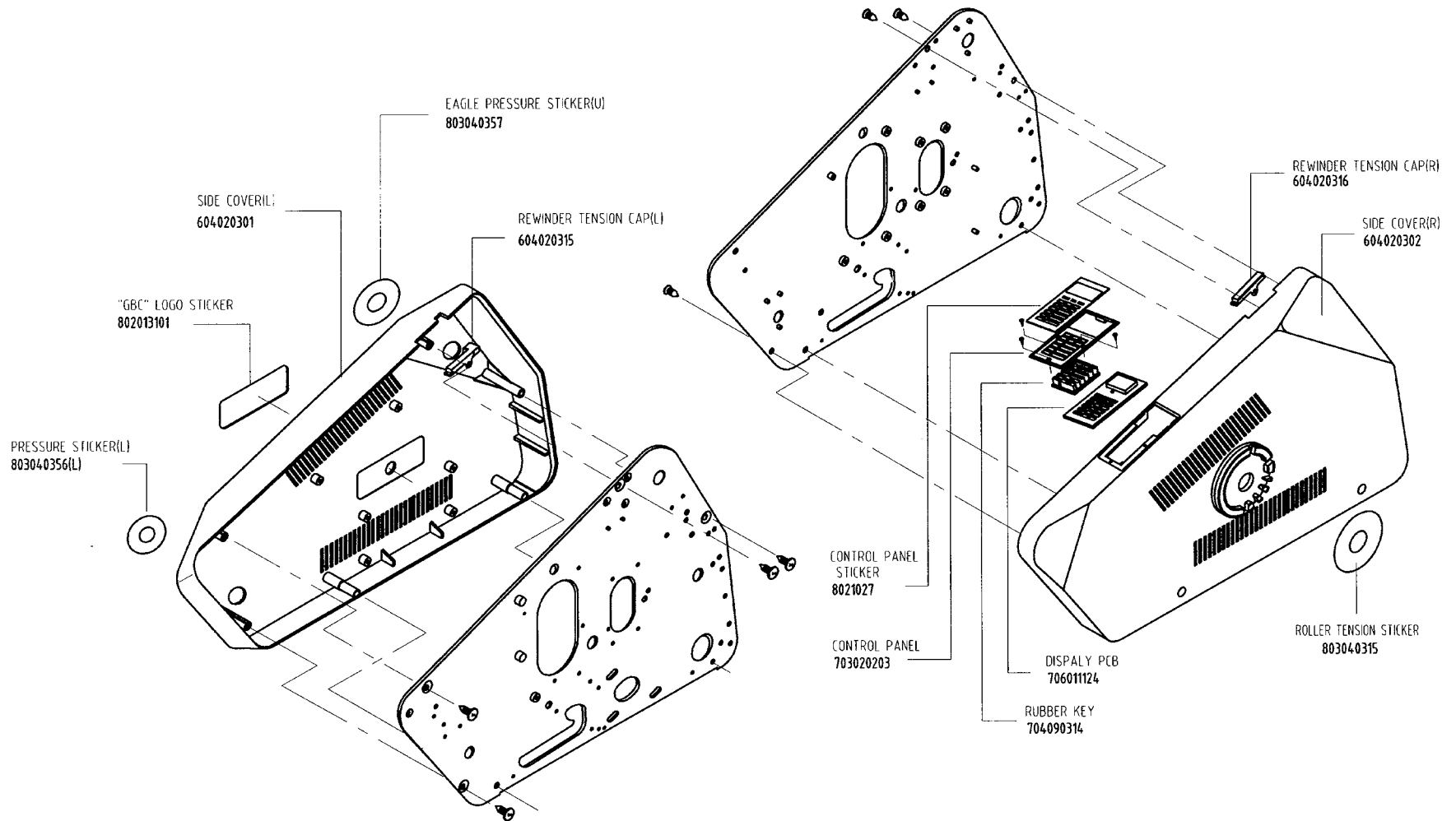

EAGLE - 65 FIRST ASSEMBLING METHOD

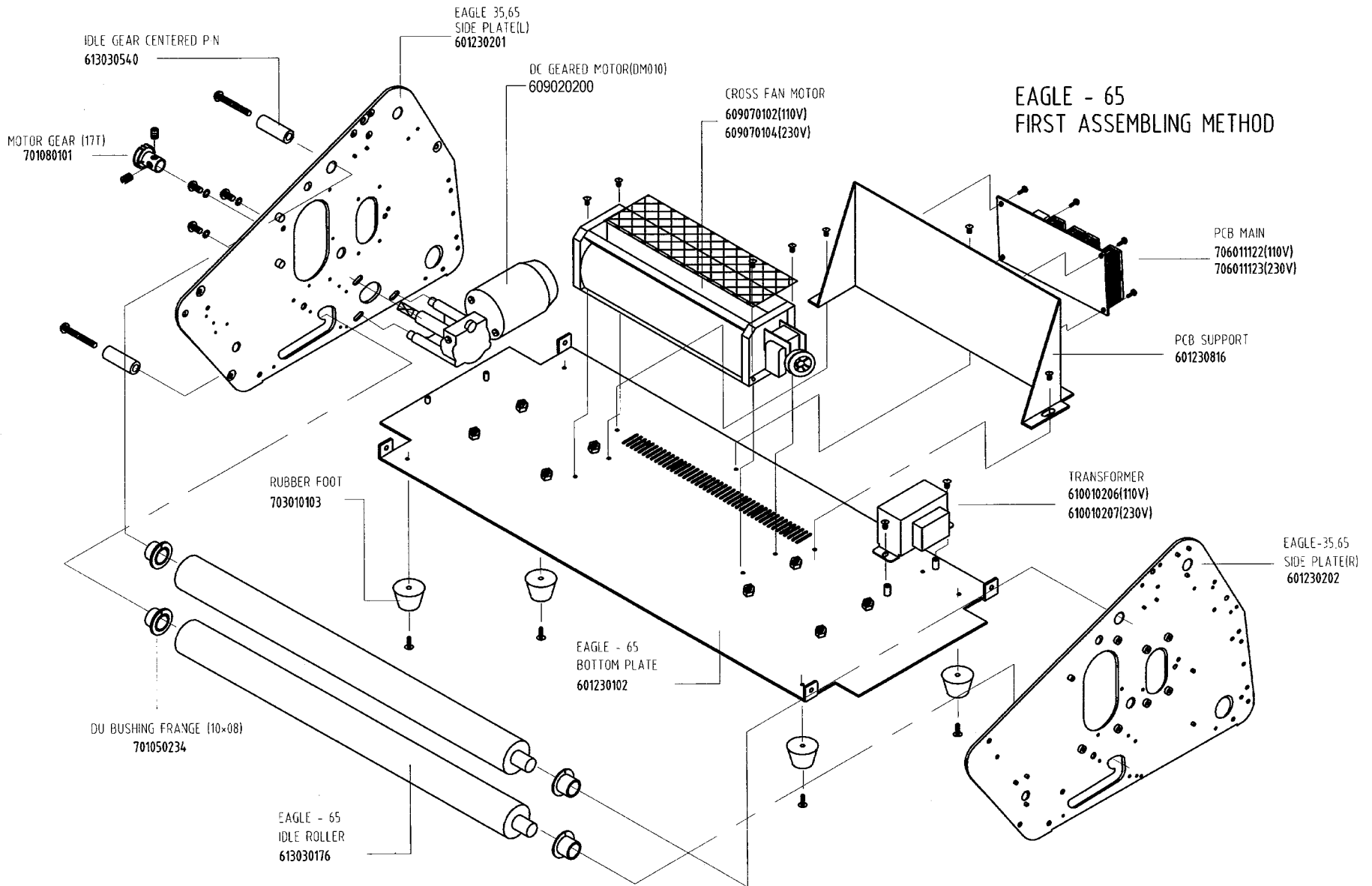

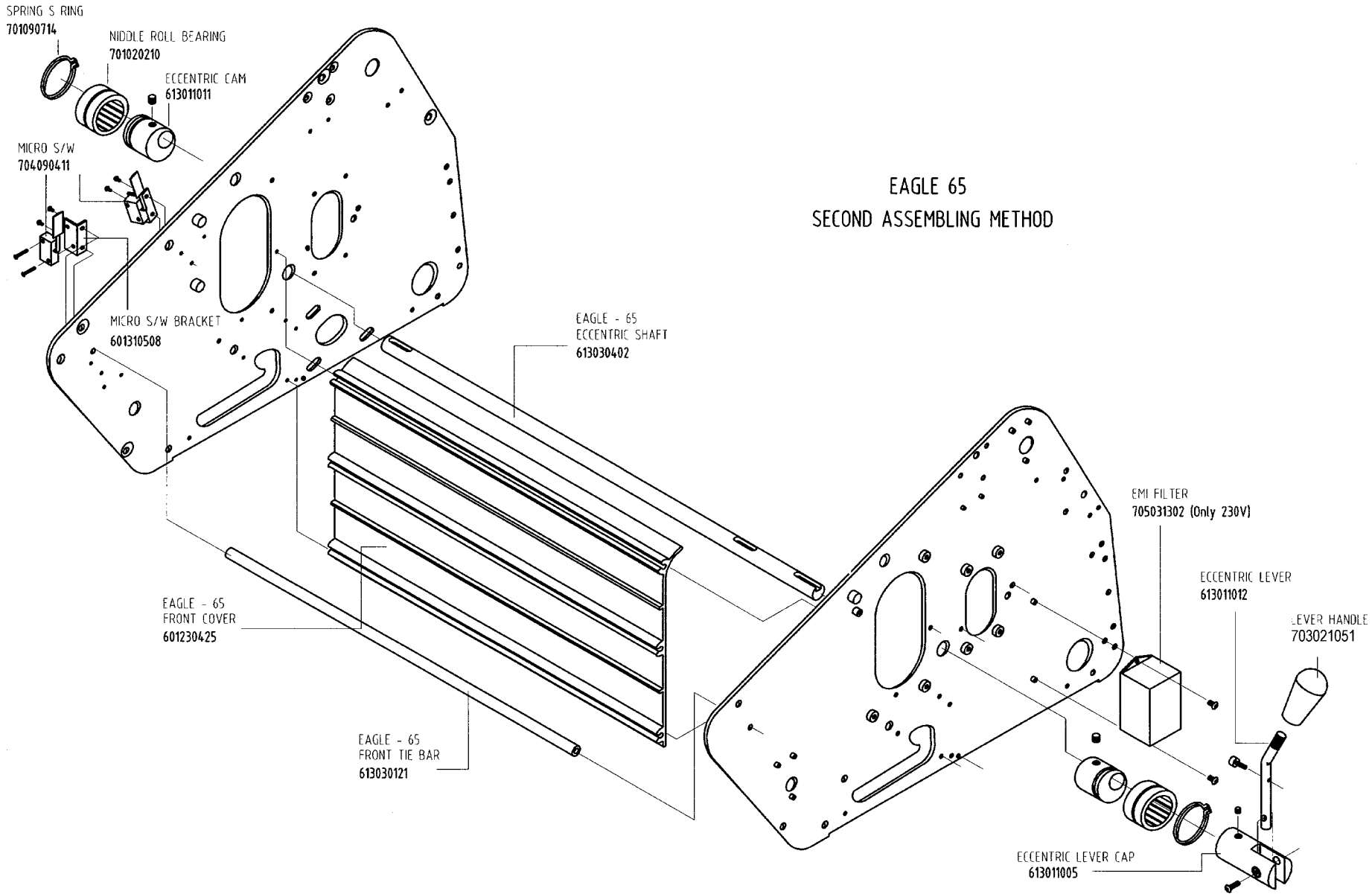

EAGLE 65
 SECOND ASSEMBLING METHOD

EAGLE 65
THIRD ASSEMBLING METHOD

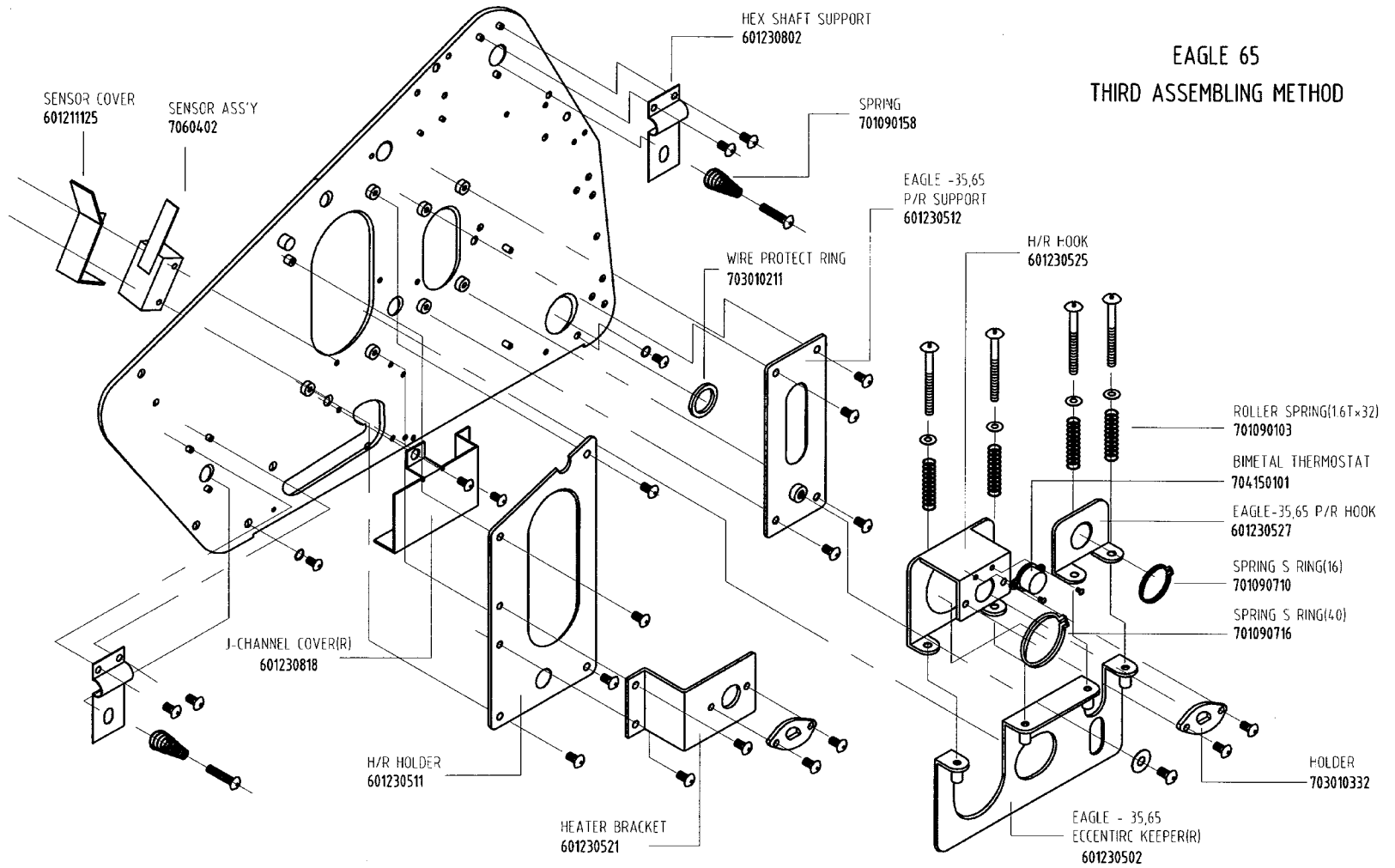

EAGLE 65 FOURTH ASSEMBLING METHOD

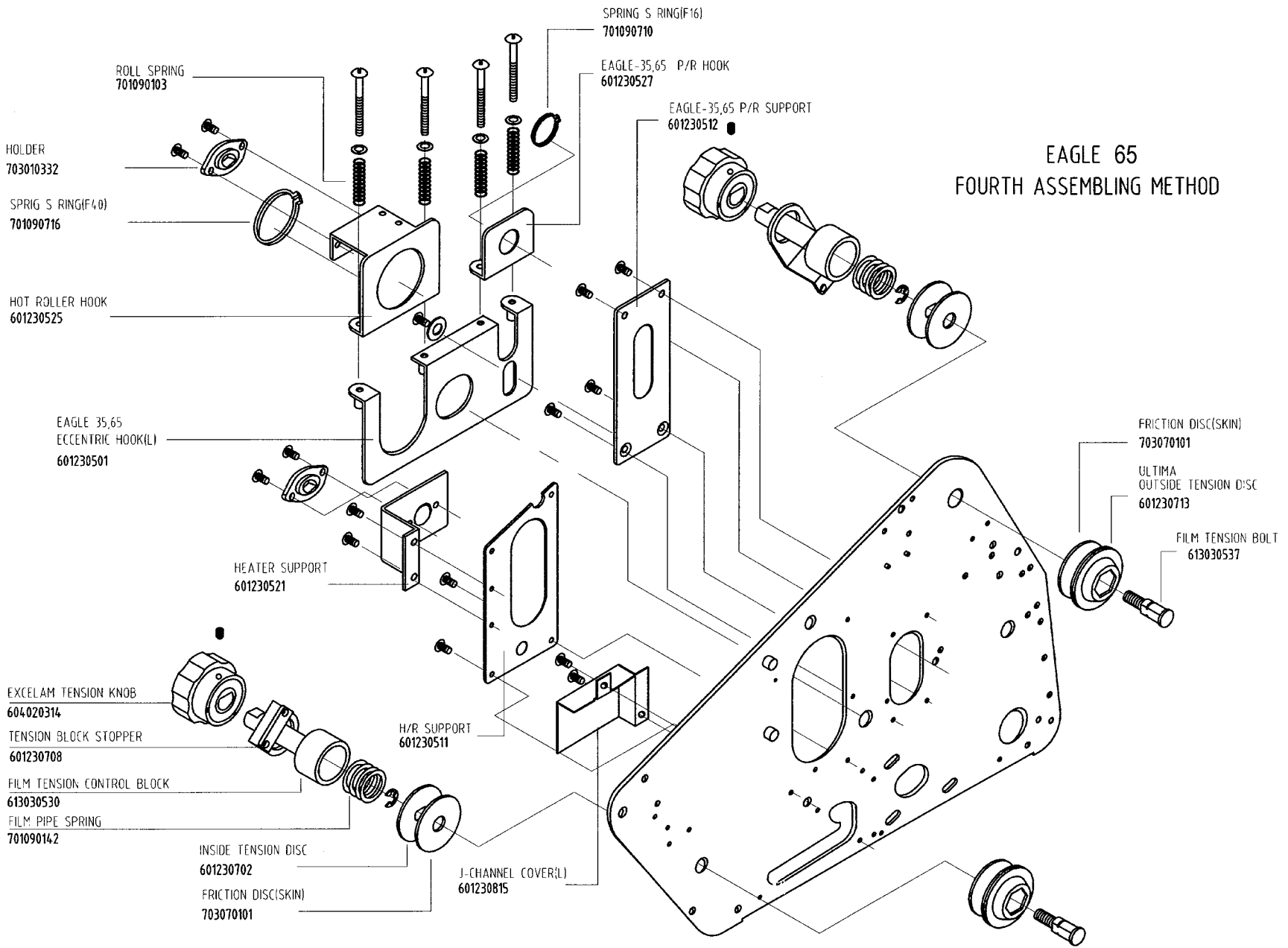

Heater Wire with connector
from main PCB to heaters
63000089

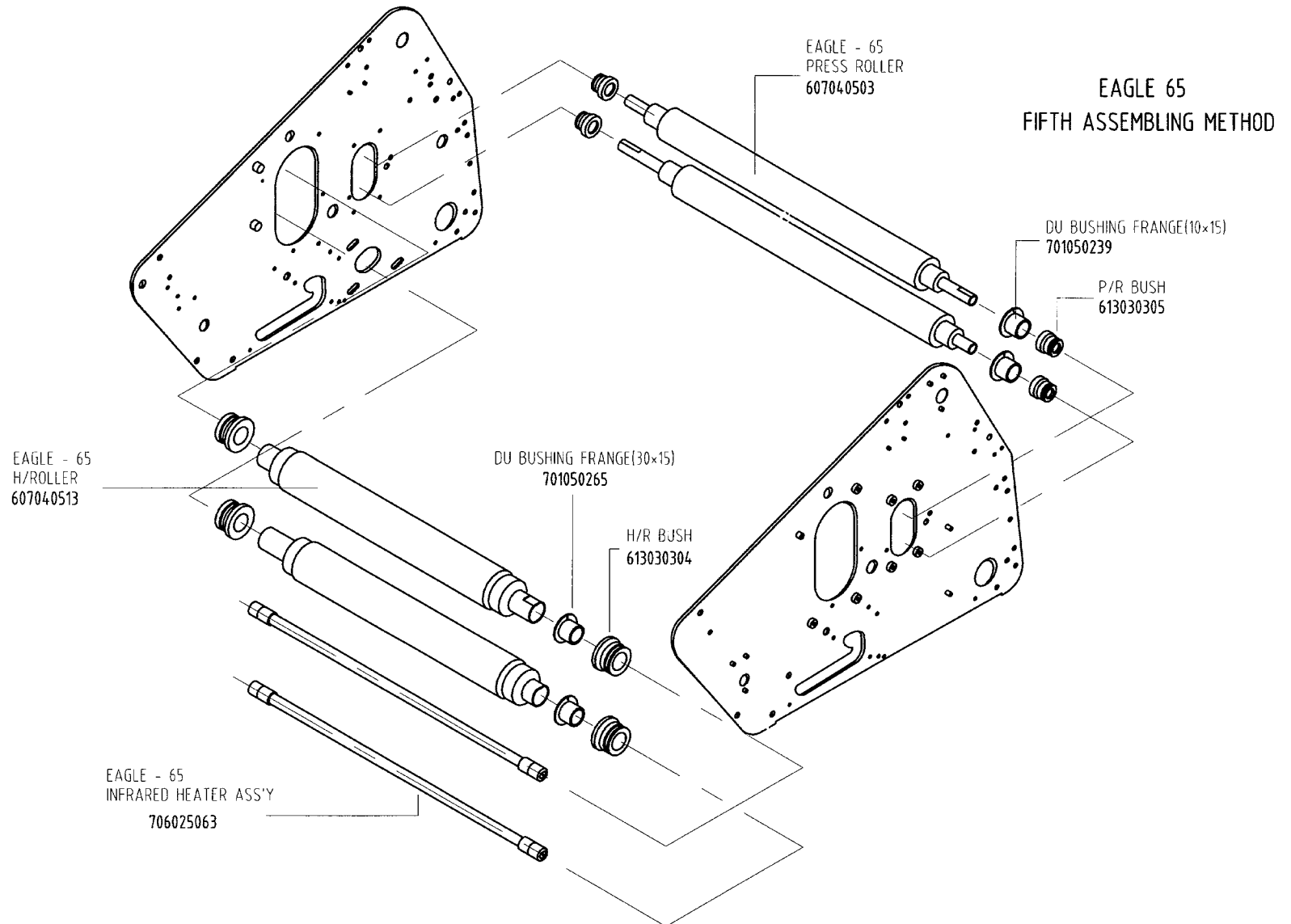

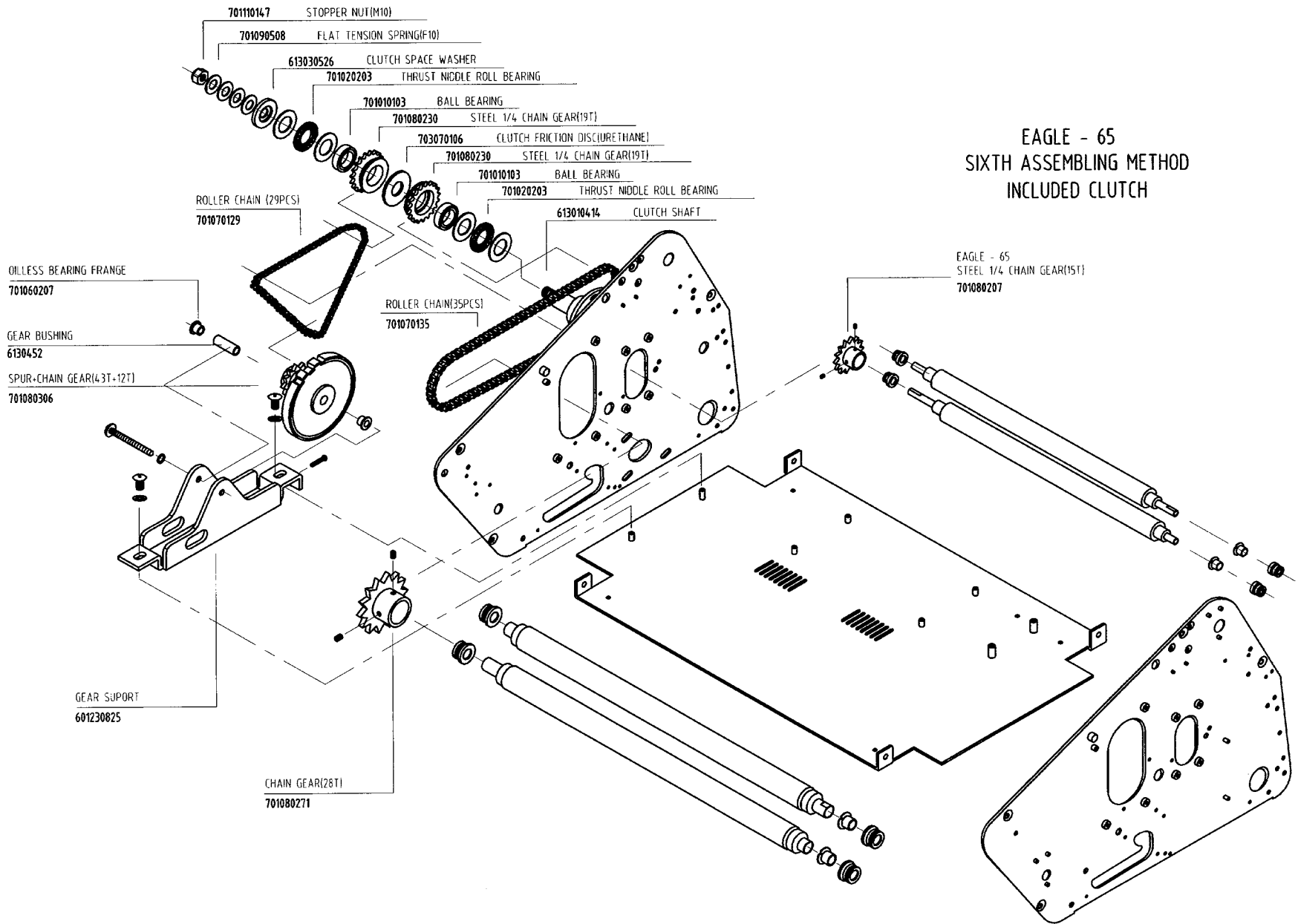

EAGLE - 65
SIXTH ASSEMBLING METHOD
INCLUDED CLUTCH

EAGLE 65 SEVENTH ASSEMBLING METHOD

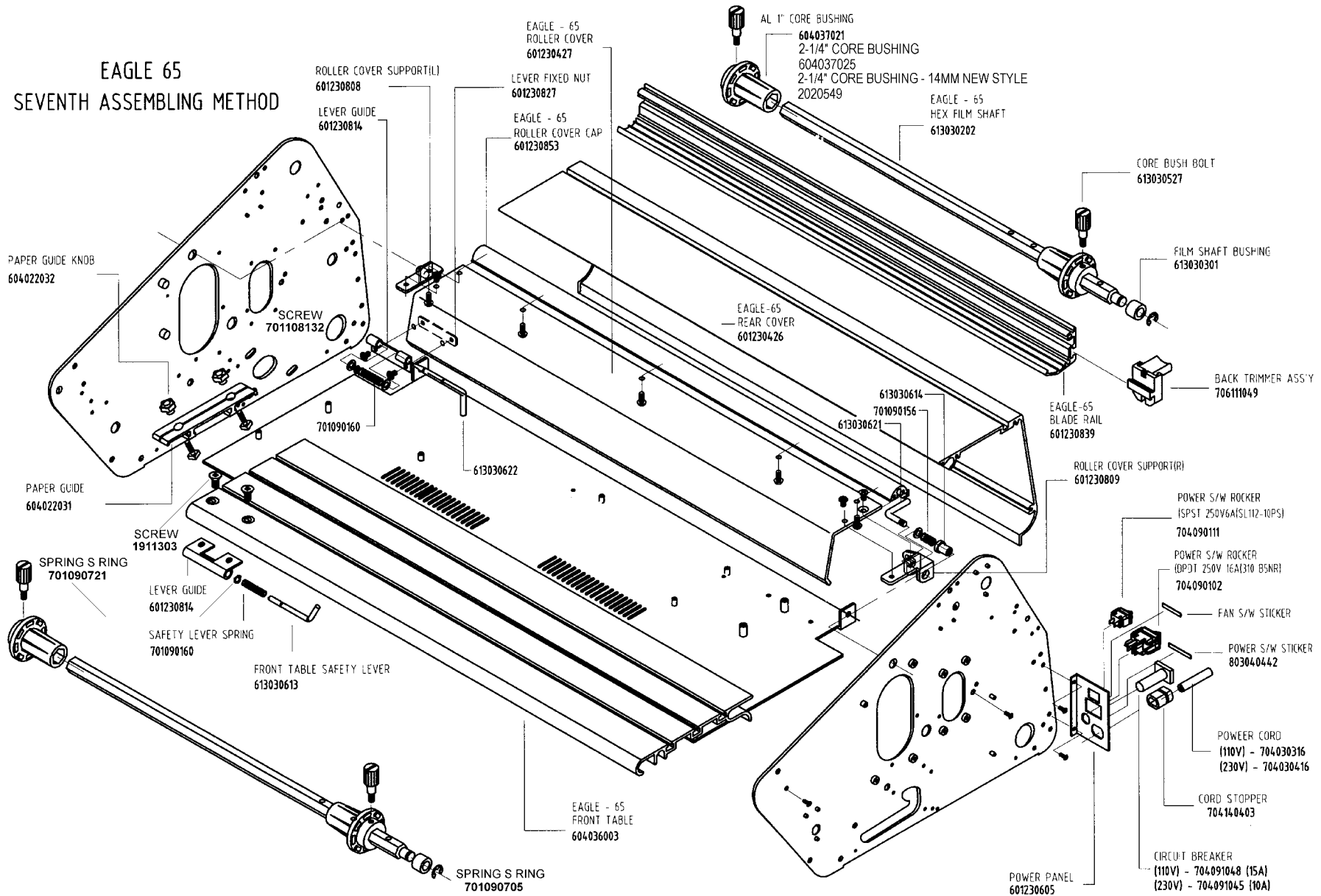

EAGLE 65 EIGHTH ASSEMBLING METHOD

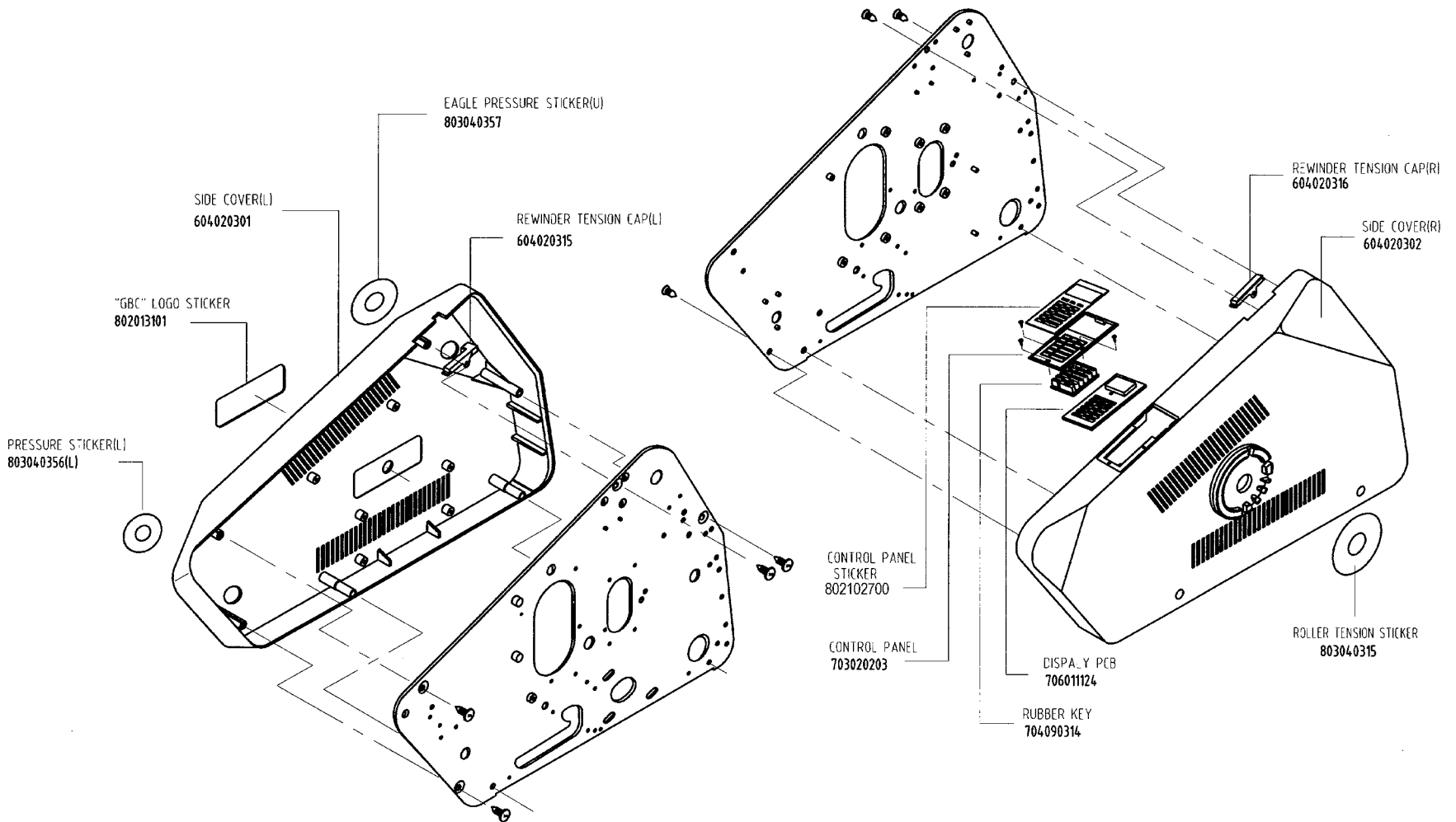

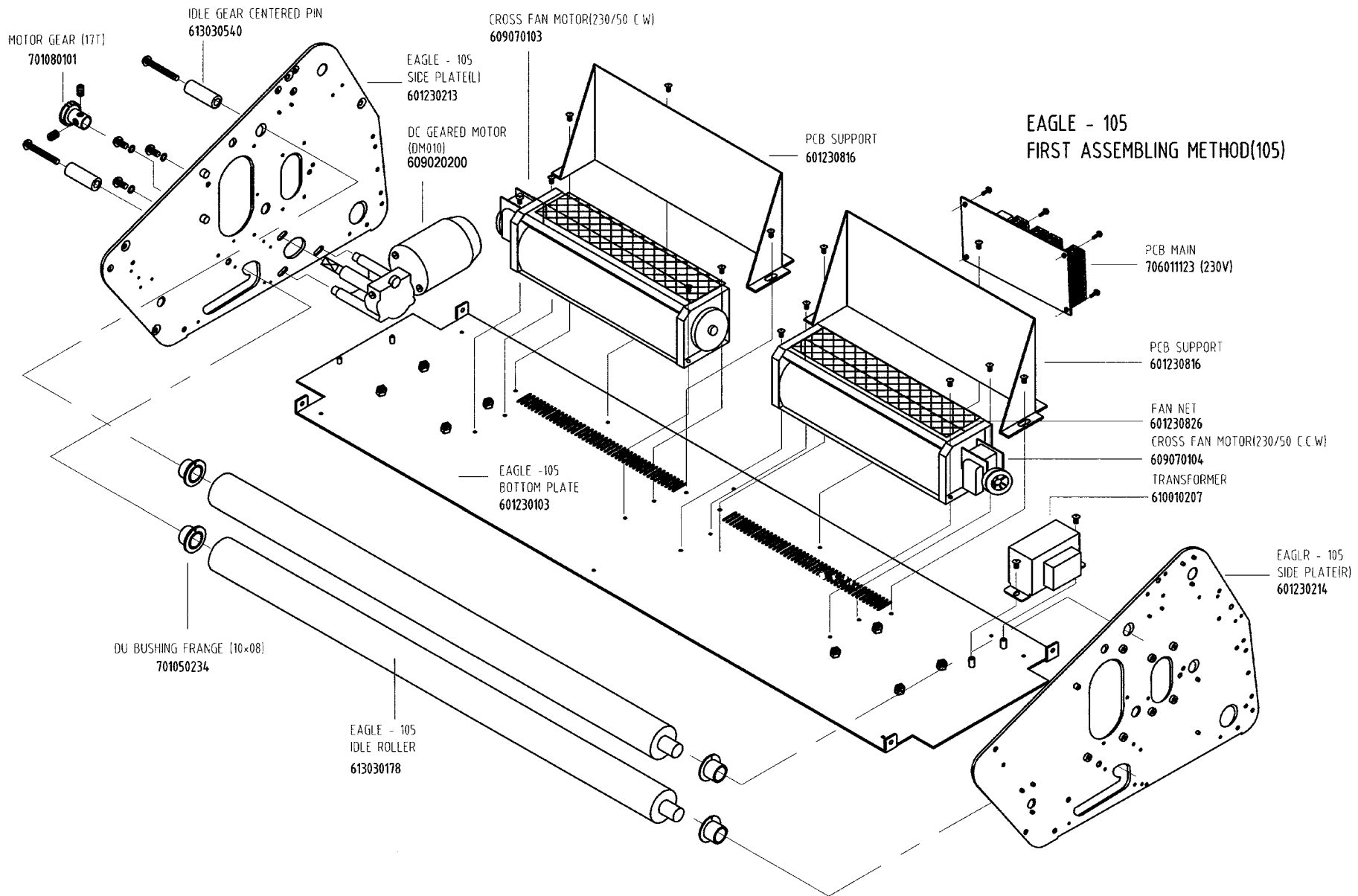

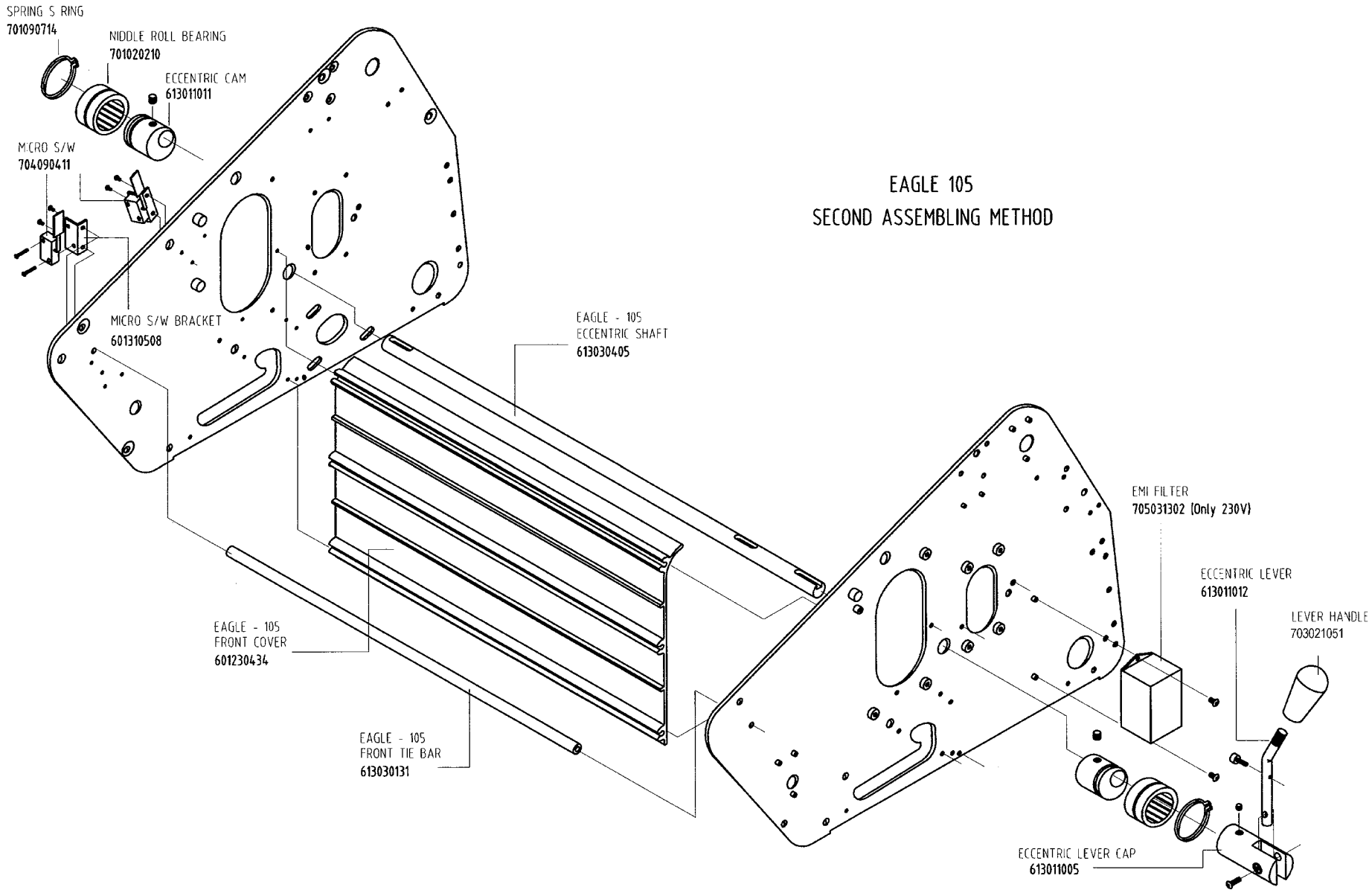

EAGLE 105 THIRD ASSEMBLING METHOD

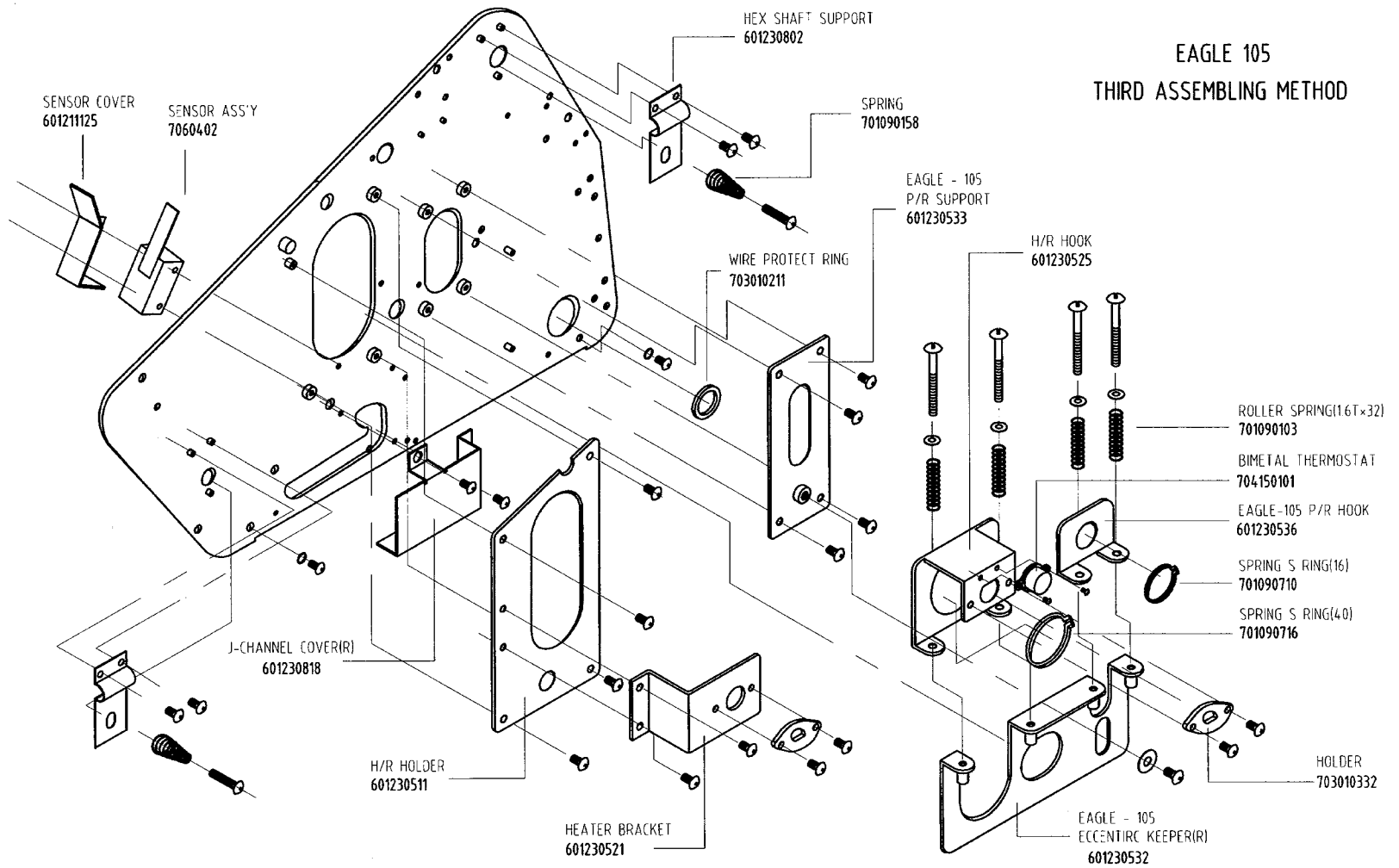

EAGLE 105 FOURTH ASSEMBLING METHOD

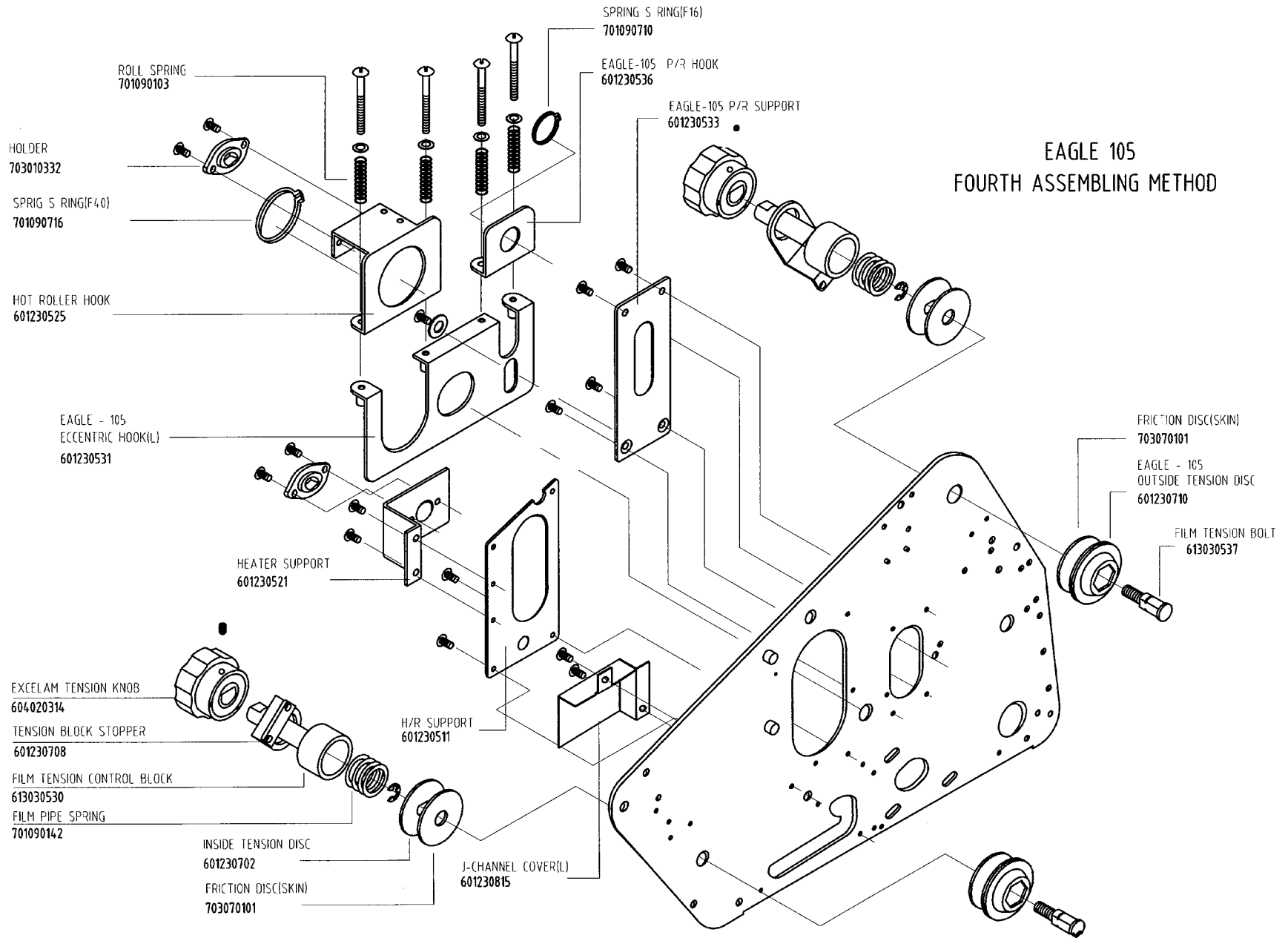

EAGLE 105 FIFTH ASSEMBLING METHOD

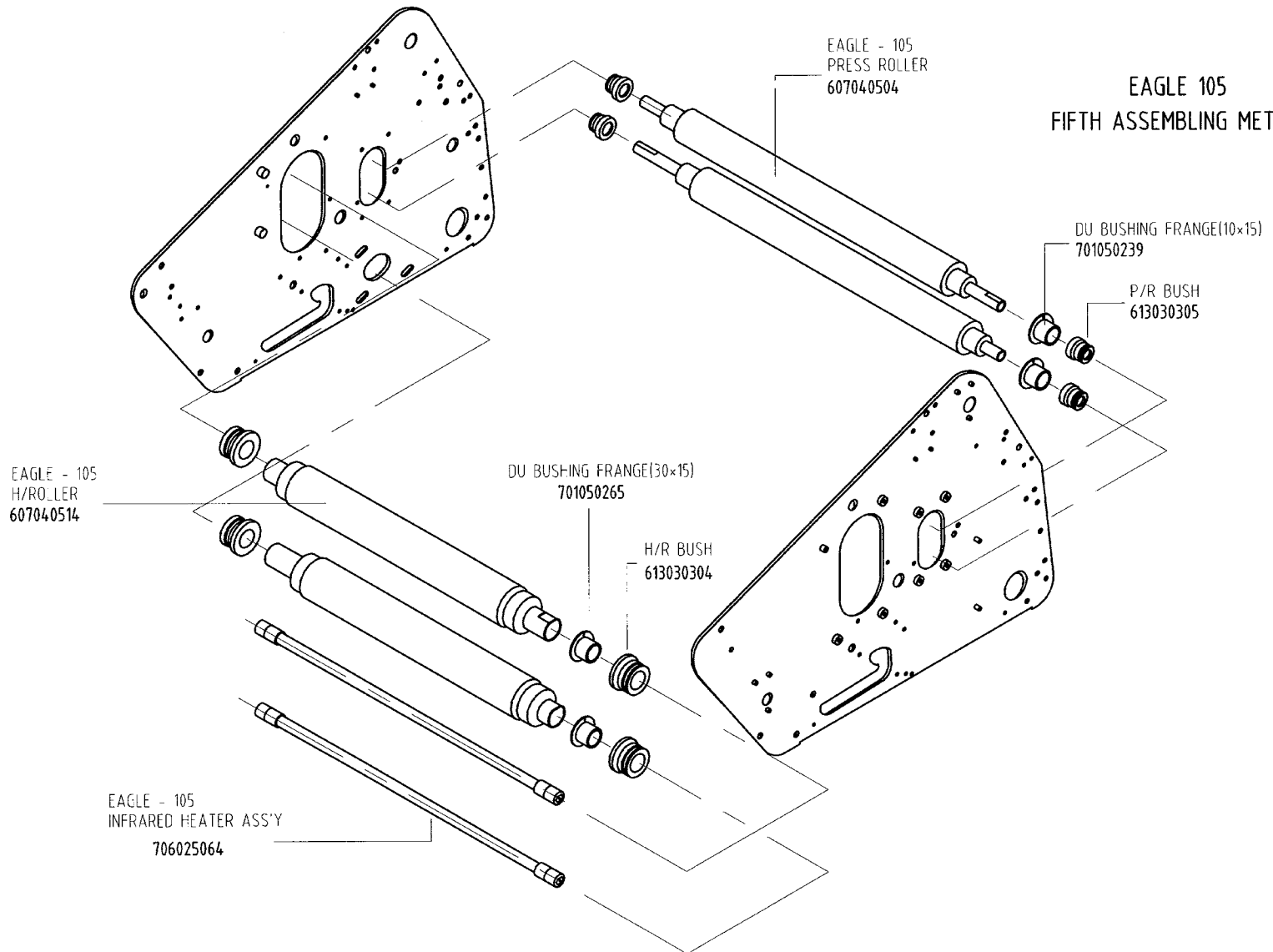

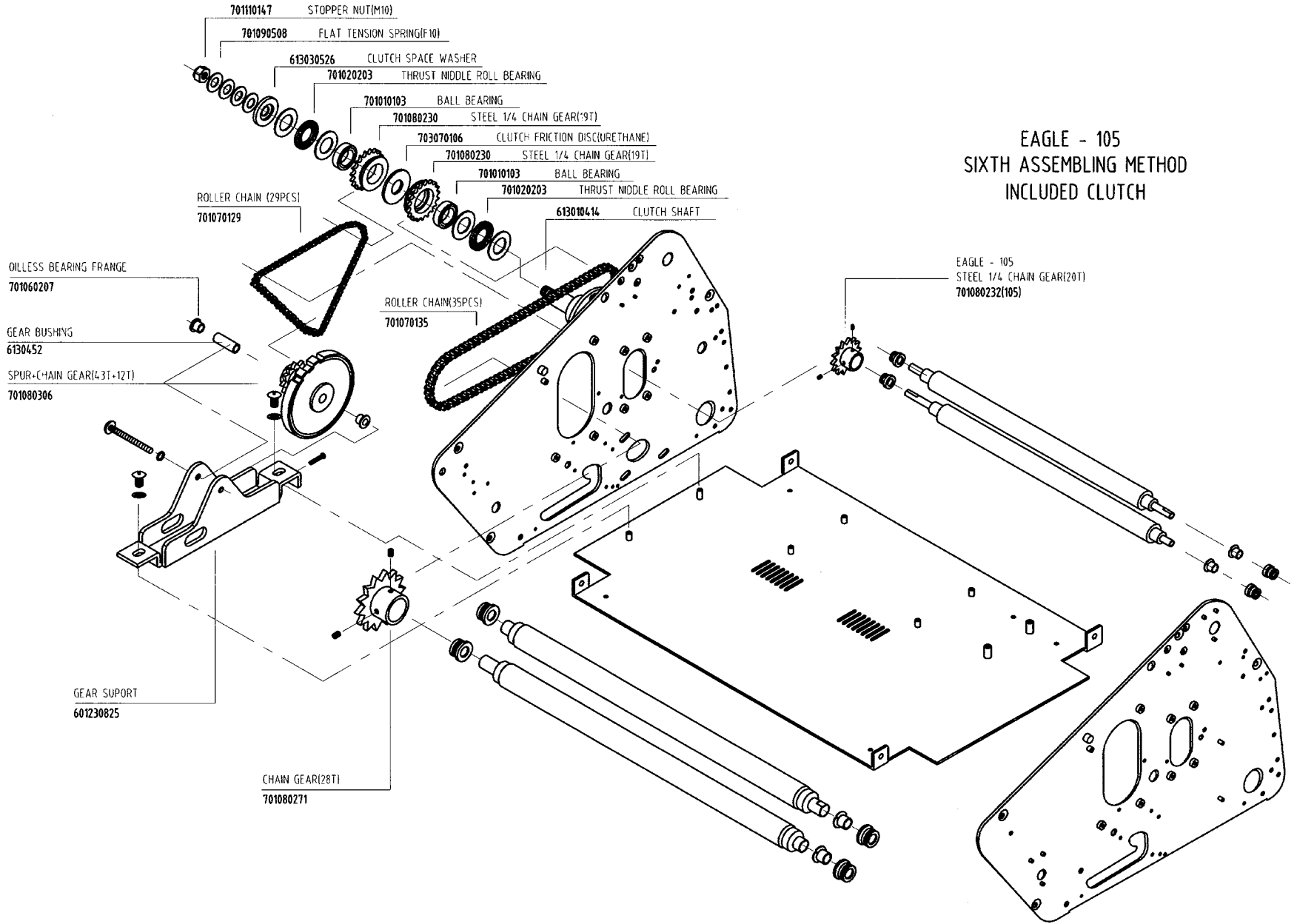

EAGLE - 105
 SIXTH ASSEMBLY METHOD
 INCLUDED CLUTCH

EAGLE 105 SEVENTH ASSEMBLING METHOD

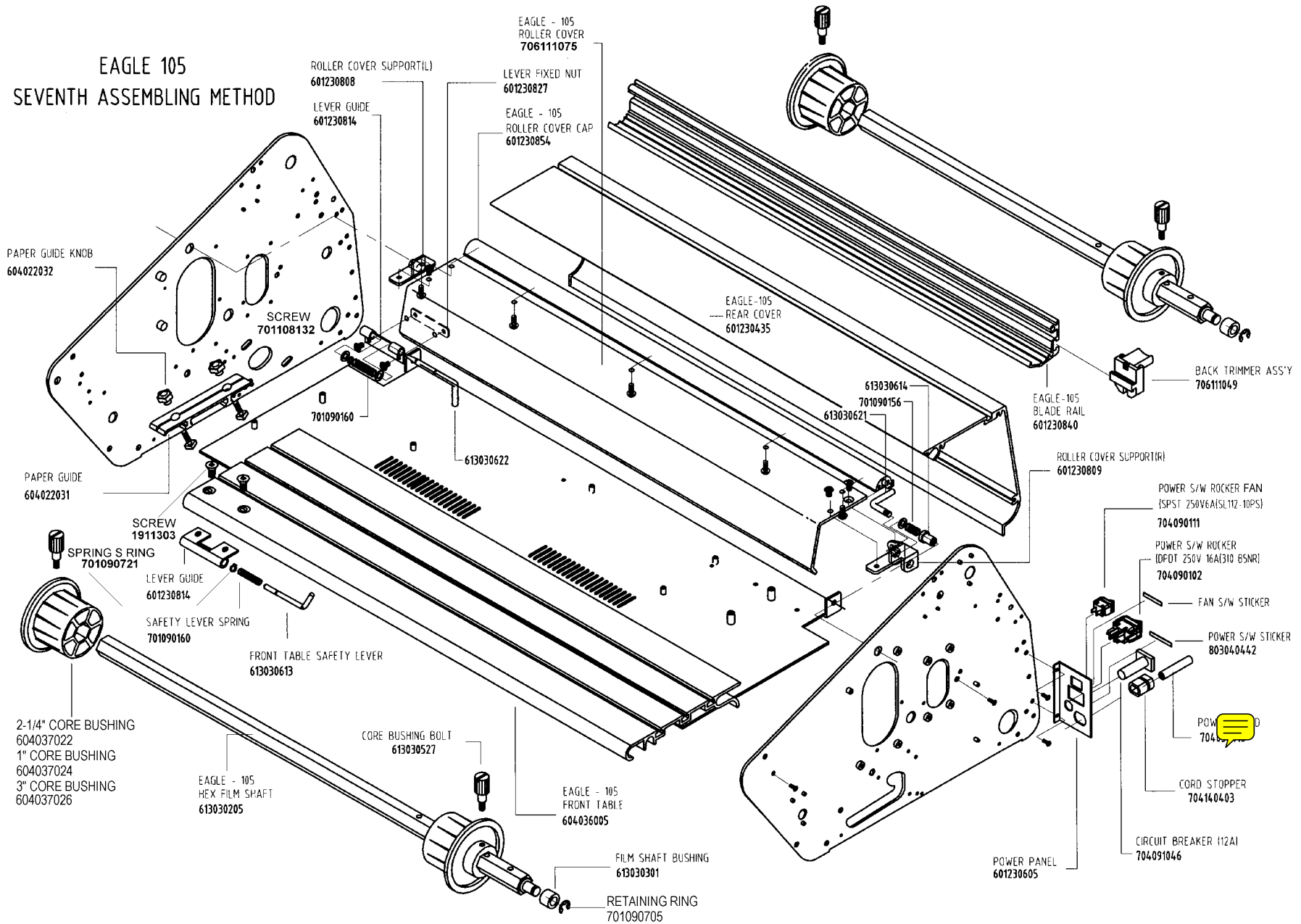

EAGLE - 105 EIGHTH ASSEMBLING METHOD

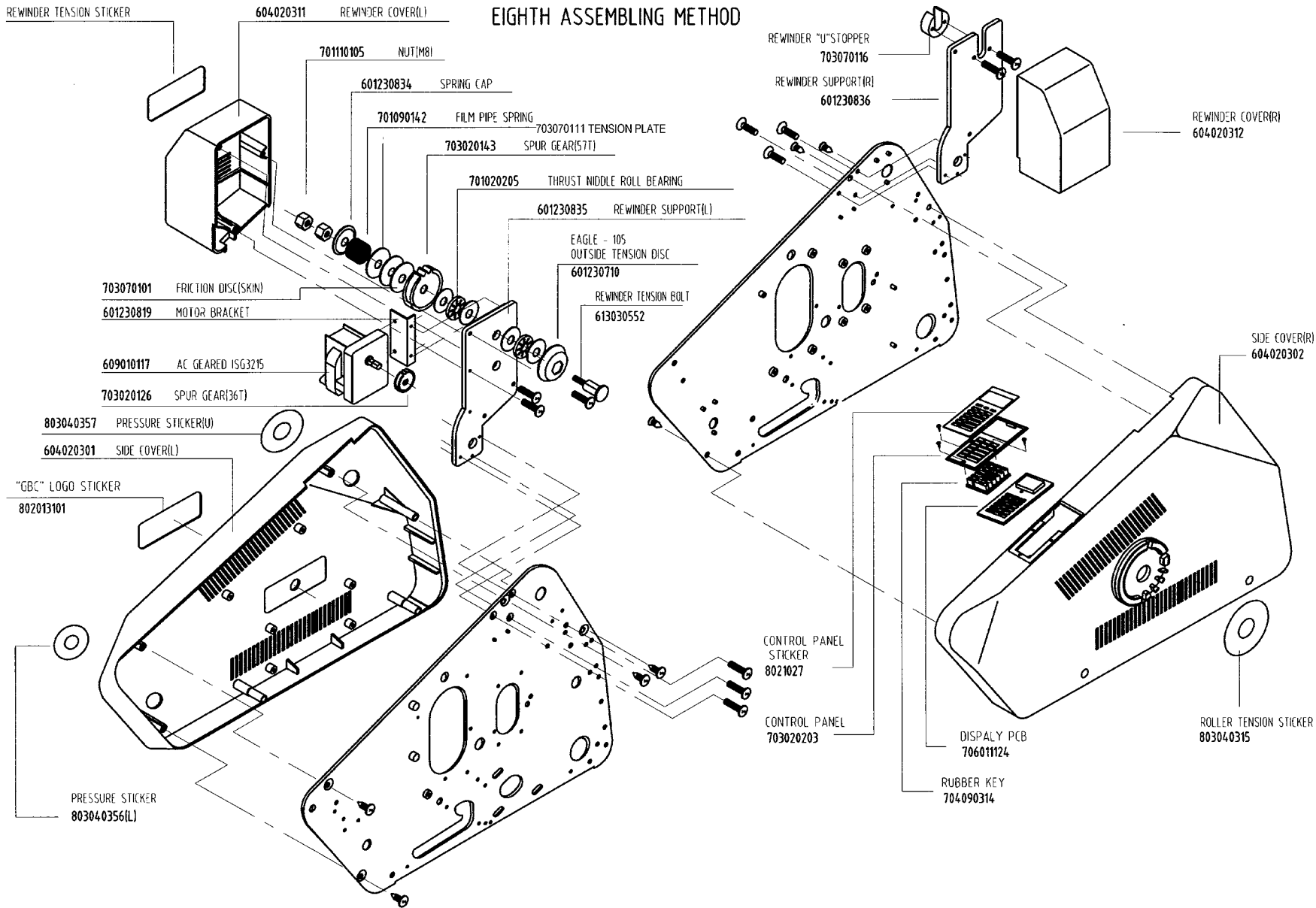

STAND ASSEMBLY 706111023

STAND SUPPORT

601230831

NUT

701110105

HEX BOLT

701107502

HEX BOLT

701107515

HEX BOLT

701107515

STAND CONNECTOR

601230832

SUPPORT ROD

601230833

CASTER

701130502

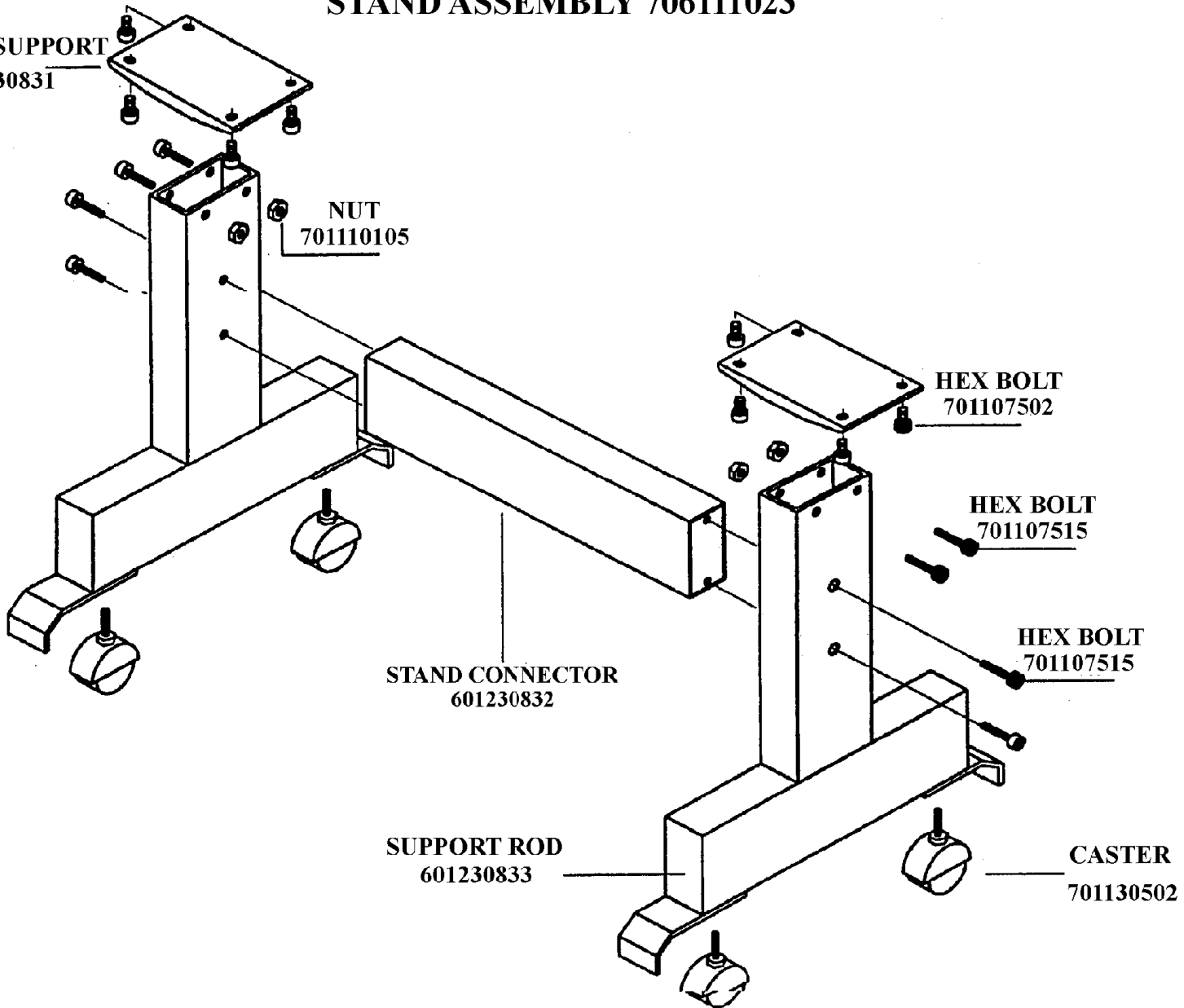



Professional Support Services
500 Bond St.
Lincolnshire, IL. 60069

NATIONAL SERVICE BULLETIN

TO: SEE DISTRIBUTION

N.S.B. NO: 210R

FROM: NATIONAL SERVICE DEPARTMENT

Page: 1 of 1

SUBJECT: **ULTIMA 65 & EAGLE 35, 65, AND 105
HEATER JUMPER WIRES W/CONNECTORES**

Date: 07/18/02

Part number 704161716 is for the Ultima 65 Heater Jumper Wires with Eyelet Connectors. Part number 704161803 is for the Eagle 35, 65, 105 Heater Jumper Wires. These wires connect to the ceramic ends of the infrared heaters. Please update your Service Manual with this information.

NOTE: Parts are on order and should be in stock within 6 to 8 weeks.



9.0 Illustrated Parts



WARNING: Illustrated parts drawings are to be used only for ordering parts. They should not be used to perform repair work yourself. Contact your local service representative for service.

The parts list is in numeric order. The parts illustration are in assembly order. If a part you require does not exist in the parts list or in the parts illustration section, contact you local service representative for assistance.

9.1 Parts list

Part #	Item Description	Machine
601211157	Back Cover Support	–
601230501	Eccentric Hook (Left)	12HR, 25HC
601230502	Eccentric Hook (Right)	12HR, 25HC
601230521	Infrared Heater Support	–
601230525	Hot Roller Hook	–
601230527	Pull Roller Hook	12HR, 25HC
601230531	Eccentric Hook (Left)	38HC
601230532	Eccentric Hook (Right)	38HC
601230536	Pull Roller Hook	38HC
601230702	Inner Tension Panel	–
601230708	Tension Block Stopper	–
601230802	Film Shaft Support Panel	–
601230819	Rewinder Gear Support	25HC, 38HC
601230824	Gear Support	12HR, 25HC
601230825	Gear Support	38HC
601230834	Spring cap, 25HC	38HC
601250101	Sensor Bracket	–
601250102	Side plate (Left)	12HR, 25HC
601250103	Side plate (Right)	12HR, 25HC
601250104	H/R Support	–
601250105	P/R Support	12HR, 25HC
601250106	Power Panel	–
601250107	Outside Tension Plate	12HR, 25HC
601250108	Bottom Plate	12HR



INFORMATION: From the parts list, (–) represents a common part for all three machines.



INFORMATION: For illustrations, each machine has its own set of drawings. 9.2 Patriot 12HR, 9.3 Patriot 25HC and 9.4 Patriot 38HC.



INFORMATION: For illustrations, the numeric value in the (), represent quantity per machine, not per assembly.

Part #	Item Description	Machine
601250109	Bottom plate	25HC
601250110	Bottom Plate	38HC
601250111	Side Plate (Left)	38HC
601250112	Rewinder support (Left)	25HC, 38HC
601250113	Rewinder support (Right)	25HC, 38HC
601250114	Outside tension plate	25HC, 38HC
601250118	P/R Support	38HC
601250119	Side Plate (Right)	38HC
601250171	Magnetic Bracket (Right)	–
601250172	Magnetic Bracket (Left)	–
601250173	Roller Cover Block	–
601250174	Roller Cover Support (Right)	–
601250175	Roller Cover Support (Left)	–
601250176	Roller Cover Bracket (Rear)	–
601250178	Table Lever	–
601250179	Table Lever Bracket	–
601250181	J-Channel Cover (Left)	–
601250182	J-Channel Cover (Right)	–
601250183	PCB support	25HC, 38HC
601310508	Micro-Switch Support	–
603010414	Clutch shaft	25HC, 38HC
603030552	Rewinder Tension Bolt	25HC, 38HC
604022032	Paper Guide Knob	–
604022101	Side Cover (Left)	–
604022102	Side Cover (Right)	–
604022103	Tension Knob	–
604022104	Rewinder Cap (Left)	12HR
604022105	Rewinder Cap (Right)	12HR
604022106	Paper Guide	–
604022109	Table Lever Guide	–
604022131	Rewinder cover (Left)	25HC, 38HC
604022132	Rewinder cover (Right)	25HC, 38HC
604036101	Front Cover	12HR
604036103	Fan Plate	12HR
604036104	Blade Rail	12HR
604036105	Roller Cover Cap	12HR
604036106	Front Table	12HR
604036107	Rear Table	12HR
604036108	Rear Cover	12HR
604036109	Roller Cover	12HR
604036111	Front Cover	25HC
604036114	Blade Rail	25HC
604036115	Roller Cover Cap	25HC
604036116	Front Table	25HC
604036117	Rear Table	25HC
604036118	Rear Cover	25HC
604036119	Roller Cover	25HC

Part #	Item Description	Machine
604036121	Front Cover	38HC
604036124	Blade Rail	38HC
604036125	Roller Cover Cap	38HC
604036126	Front Table	38HC
604036127	Rear Table	38HC
604036128	Rear Cover	38HC
604036129	Roller Cover	38HC
604037021	1 In. Core Bushing	12HR, 25HC
604037022	2 in. Core Bushing	38HC
604620102	Metal Magnet	–
607040501	Pull Roller	12HR
607040503	Pull Roller	25HC
607040504	Pull Roller	38HC
607040511	Heat Roller	12HR
607040513	Heat Roller	25HC
607040514	Heat Roller	38HC
609010116	A/C geared, ISG3215	25HC, 38HC
6090202	DC Geared Motor	–
609040201	Fan Motor AC 80mm	12HR
609070102	Cross Fan Motor	25HC
609070103	Cross Fan Motor (Left)	38HC
609070104	Cross Fan Motor (Right)	38HC
610010207	Transformer, 240/35/1.8	38HC
610010211	Transformer, 120/36/1.3	12HR, 25HC
613010414	Clutch shaft (PL)	25HC, 38HC
613011005	Eccentric Lever Stopper (PL)	–
613011011	Eccentric Bushing (PL)	–
613011012	Eccentric Lever (PL)	–
613030111	Feed Table Support Rod (PL)	12HR
613030121	Feed Table Support Rod (PL)	25HC
613030131	Feed Table Support Rod (PL)	38HC
613030174	Idler Roller (PL)	12HR
613030176	Idler Roller (PL)	25HC
613030178	Idler Roller (PL)	38HC
613030201	Hex Film Shaft (PL)	12HR
613030202	Hex Film Shaft (PL), 14	25HC
613030205	Hex Film Shaft (PL), 19	38HC
613030210	Hex Film Shaft (PL), 19	25HC
613030301	Film Shaft Bushing (PL)	–
613030304	H/R Bushing (PL)	–
613030305	P/R Bushing (PL)	–
613030401	Eccentric Shaft (PL)	12HR
613030402	Eccentric Shaft (PL)	25HC
613030405	Eccentric Shaft (PL)	38HC
613030526	Clutch Spacer Washer (PL)	25HC, 38HC
613030527	Core Bushing Bolt (PL)	–
613030530	Tension Adjustment Block (PL)	–

Part #	Item Description	Machine
613030540	Auxiliary Gear Support Pin (PL),	–
6130452	Auxiliary Gear Bushing HR, 21 mm	–
701010103	Ball Bearing	25HC, 38HC
701020203	Thrust Needle Bearing, 1730	25HC, 38HC
701020205	Thrust Needle Bearing, 1226	25HC, 38HC
701020210	Needle Roller Bearing, RNA4903	–
701050239	Flange Bushing, 10 -15	–
701050265	Flange Bushing, 3015	–
701060207	Oilless Flange Bushing	–
701070129	Roller Chain, 29 pc	25HC, 38HC
701070131	Roller Chain, 31 pc	12HR
701070135	Roller Chain, 35 pc	25HC, 38HC
701080101	Steel Spur Gear, 17T	–
701080207	Steel Spur Gear, 15T	12HR, 25HC
701080230	Steel Chain Gear, 19T	25HC, 38HC
701080232	Steel Chain Gear, 20T	38HC
701080271	Steel 1/4 Chain Gear	28T, -
701080301	Steel Spur + Chain Gear, 43T + 12T	12HR, 25HC
701080306	Steel Spur + Chain Gear, 43T + 12T	38HC
701090103	Roller Spring	–
701090142	Film Pipe Spring, 17.5 mm	–
701090156	Compressed Coil Spring, 12.5 mm	–
701090169	Lever Spring	–
701090508	Flat Tension Spring	25HC, 38HC
701090710	Snap Ring	–
701090716	Snap Ring	–
701110105	Nut, M8	25HC, 38HC
701110147	Stopper Nut, M10	25HC, 38HC
703010103	Rubber Foot	12HR, 25HC
703010211	Wire Protection Ring	–
703010332	Holder	–
703020126	Plastic Spur Gear, 36T	25HC, 38HC
703020143	Plastic Spur Gear	25HC, 38HC
703020242	Control Panel	–
703021051	Eccentric Lever Handle (ROLL)	–
703070101	Friction Panel (Leather)	–
703070106	Clutch Friction (Urethane)	25HC, 38HC
703070111	Tension Plate	25HC, 38HC
703070116	Rewinder “U” Channel Stopper	25HC, 38HC
704030316	Cord Plug 125V UL	12HR, 25HC
704031123	Cord Plug Inlet 250V (USA)	38HC
704090102	Power Switch, Rocker	–
704090336	Rubber Key Pad	–
704090411	Micro-Switch, Table	–
704090423	Micro-Switch, Safety Shield	–
704091046	Circuit Breaker, 12A	38HC
704091048	Circuit Breaker, 15A	12HR, 25HC

Part #	Item Description	Machine
704140403	Cord Stopper	–
704150101	Bi-Metal Thermostat, 130 deg	12HR, 25HC
704150103	Bi-Metal Thermostat, 140 deg	38HC
705200201	Infrared Sensor	–
706011106	Main PCB	–
706011107	Display PCB	–
706025061	Infrared Heater Assembly, 18 ohm	12HR
706025063	Infrared Heater Assembly, 16 ohm	25HC
706025064	Infrared Heater Assembly, 45 ohm	38HC
706111121	Back Trimmer Assembly	–
802034301	Patriot 12HR Decal, Front	–
802034302	Decal, Side	12HR
802034303	Decal, Side	25HC
802034304	Decal, Side	38HC
803021701	Serial Plate	12HR
803021711	Serial Plate	25HC
803021721	Serial Plate	38HC
803040315	Roller Tension Sticker	–
803040323	Shock Hazard Warning Sticker	–
803040325	Sharp Blade Warning Sticker	–
803040326	Pull Roller Warning Sticker	–
803040327	Hot Rolls Pinch Point Warning Sticker	–
803040329	Do Not Operate Warning Sticker	–
804020403	Paper Core	25HC
804020404	Paper Core	38HC
8050112	Paper Core Stopper, 57 mm	25HC, 38HC

END OF LIST

9.2 Patriot 12HR Illustrations

PROPRIETARY
 GBC PRO-TECH CLAIMS PROPRIETARY RIGHTS TO THE MATERIAL DISCLOSED ON THIS DRAWING. IT IS ISSUED IN CONFIDENCE FOR ENGINEERING INFORMATION ONLY AND SHALL NOT BE REPRODUCED, COPIED OR DISCLOSED IN WHOLE OR IN PART, OR USED FOR MANUFACTURE OR FOR ANY OTHER PURPOSE WITHOUT WRITTEN PERMISSION FROM GBC PRO-TECH.

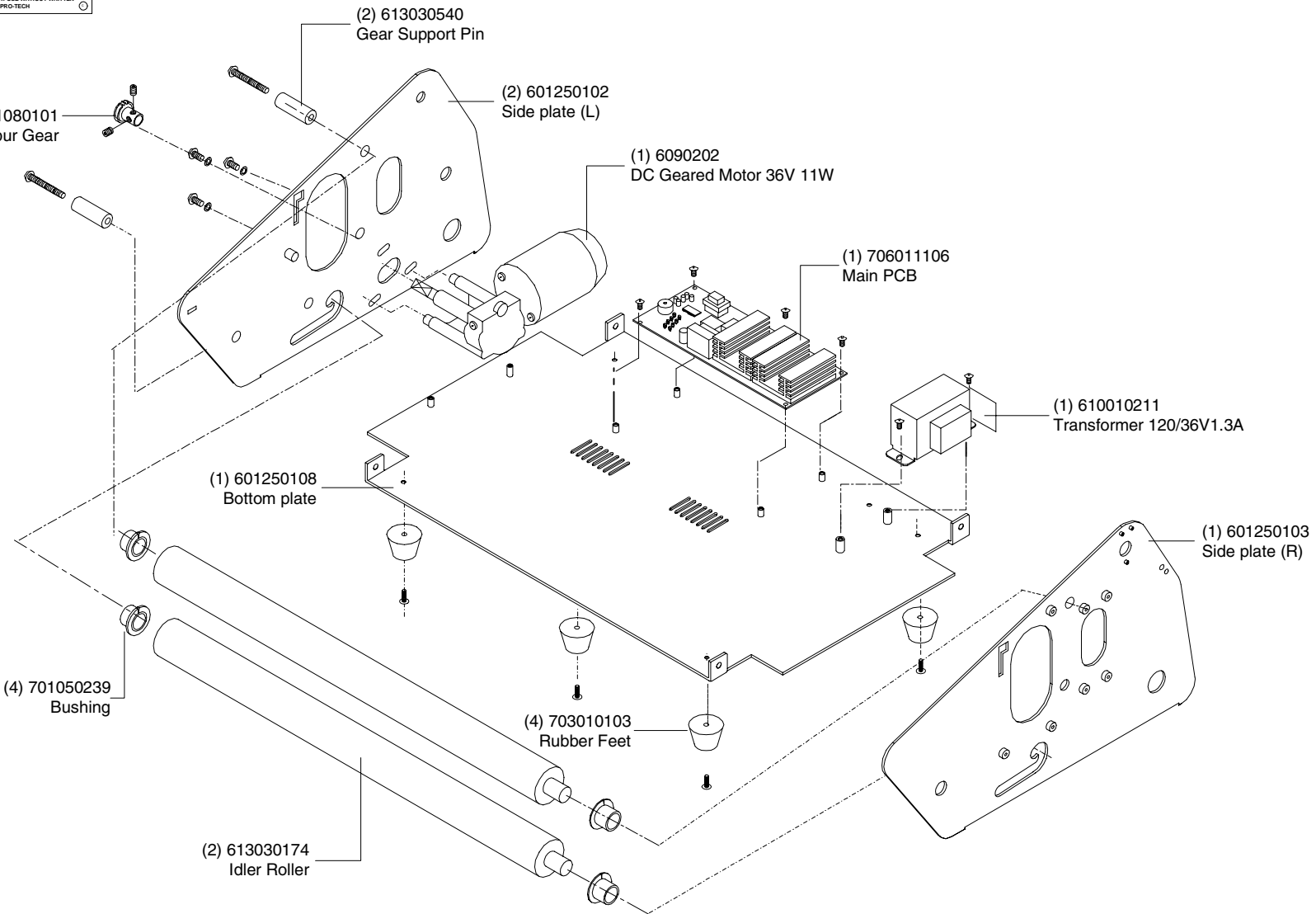

UNLESS OTHERWISE SPECIFIED TOLERANCE				GBC Films Group 4151 Anderson Road, DeForest, WI 53532		
DIM AS SHOWN	TOL.	FRESH TO BE	125 ✓	TITLE: Assembly, Frame Patriot 12HR		
XX	±.184			DATE: 07/01/02	DRAWN BY: NSG	DWG SCALE: N/A
X	±.059			DWG: P12HR-001		
XX	±.010					
XXX	±.020					
XXXX	±.05					
ANGLES ±.0						

PROPRIETARY

GBC PRO-TECH CLAIMS PROPRIETARY RIGHTS TO THE MATERIAL DISCLOSED ON THIS DRAWING. IT IS ISSUED IN CONFIDENCE FOR ENGINEERING INFORMATION ONLY AND SHALL NOT BE REPRODUCED, COPIED OR DISCLOSED IN WHOLE OR IN PART, OR USED FOR MANUFACTURE OR FOR ANY OTHER PURPOSE WITHOUT WRITTEN PERMISSION FROM GBC PRO-TECH

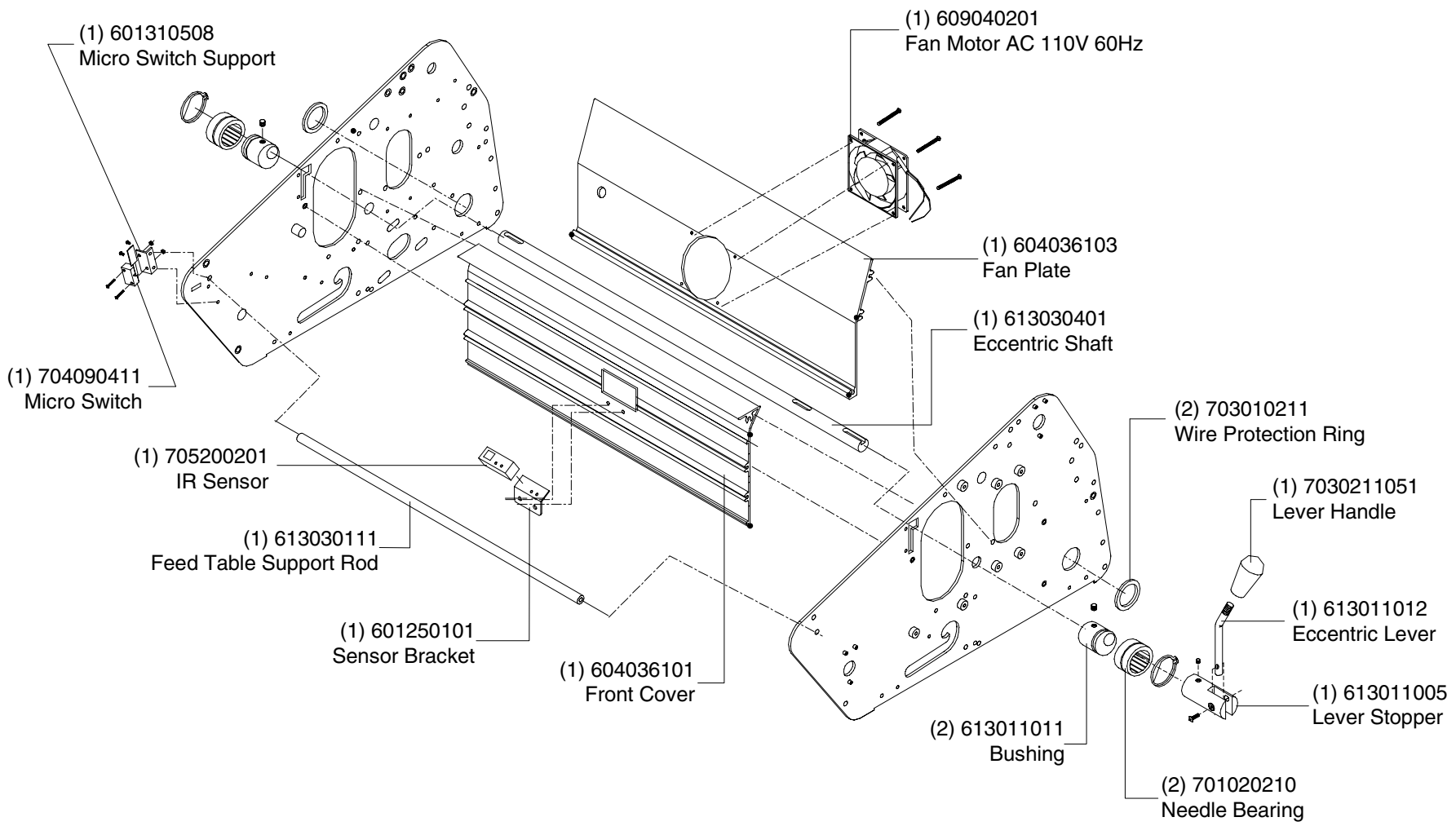

UNLESS OTHERWISE SPECIFIED TOLERANCE				GBC Films Group 4151 Anderson Road, DeForest, WI 53532			
DM. AS SHOWN	TOL.	FINISH TO BE	125	TITLE: Assembly, Bridge Patriot 12HR			
X	±.184			DATE: 07/01/02	DRAWN BY: NSG	DWG SCALE: N/A	DWG: P12HR-002
X	±.000			CHECKED BY: GBC FILMS GROUP			
XX	±.010			REVISION			
XXX	±.000	ANGLES ±.5°					
XXXX	±.000						

PROPRIETARY
 GBC PRO-TECH CLAIMS PROPRIETARY RIGHTS TO THE MATERIAL DISCLOSED ON THIS DRAWING. IT IS ISSUED IN CONFIDENCE FOR ENGINEERING INFORMATION ONLY AND SHALL NOT BE REPRODUCED, COPIED OR DISCLOSED IN WHOLE OR IN PART, OR USED FOR MANUFACTURE OR FOR ANY OTHER PURPOSE WITHOUT WRITTEN PERMISSION FROM GBC PRO-TECH

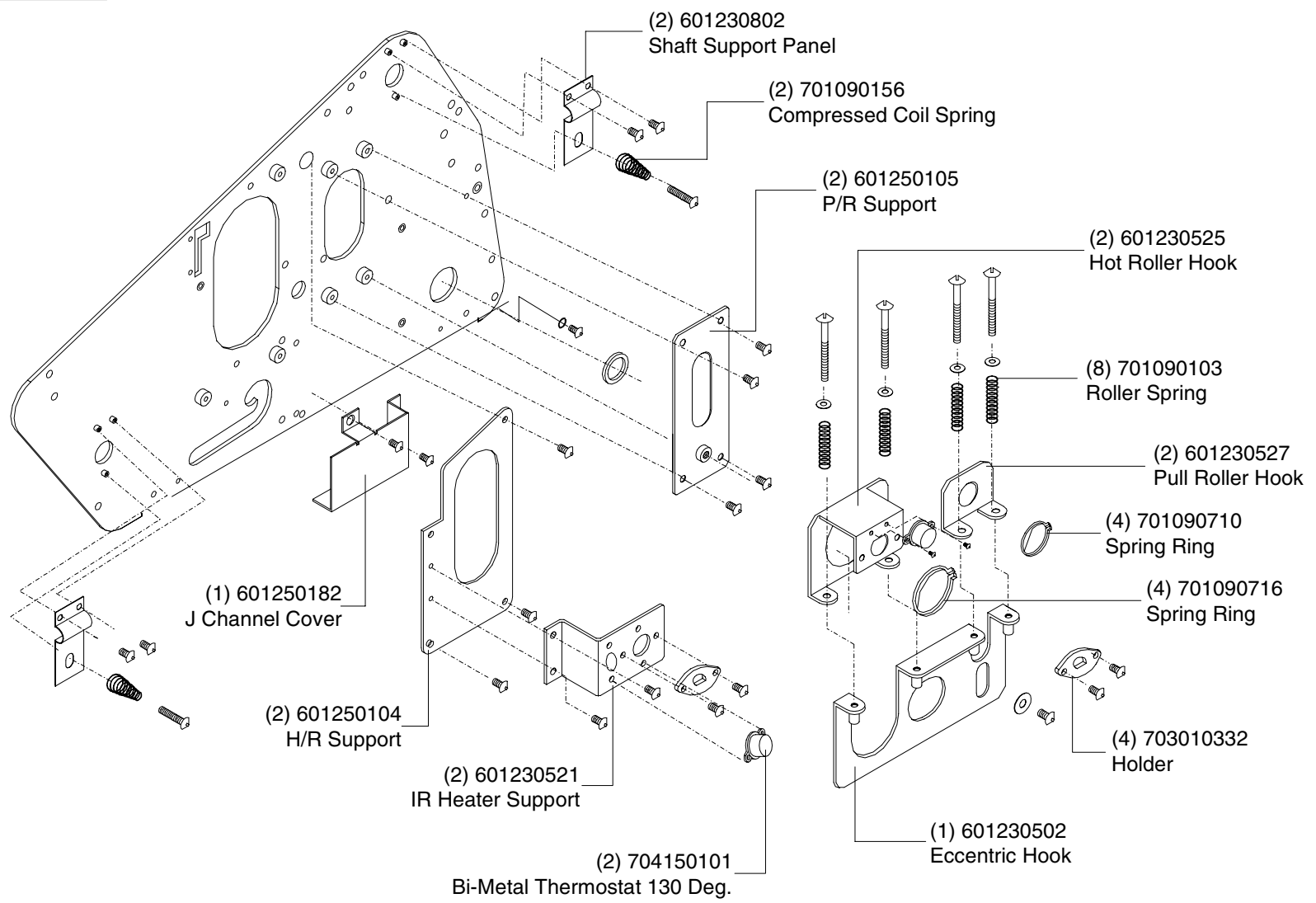

UNLESS OTHERWISE SPECIFIED TOLERANCE				GBC Films Group 4151 Anderson Road, DeForest, WI 53532			
DM. AS SHOWN	TOL.	FINISH TO BE	1/2 √	TITLE : Assembly, Control side Patriot 12HR			
XX	±.184			DATE : 07/02/02	DRAWN BY : NSG	DWG SCALE : N/A	DWG : P12HR-003
X	±.050						
XX	±.010						
XX	±.020	ANGLES					
XXXX	±.005	±.0°					

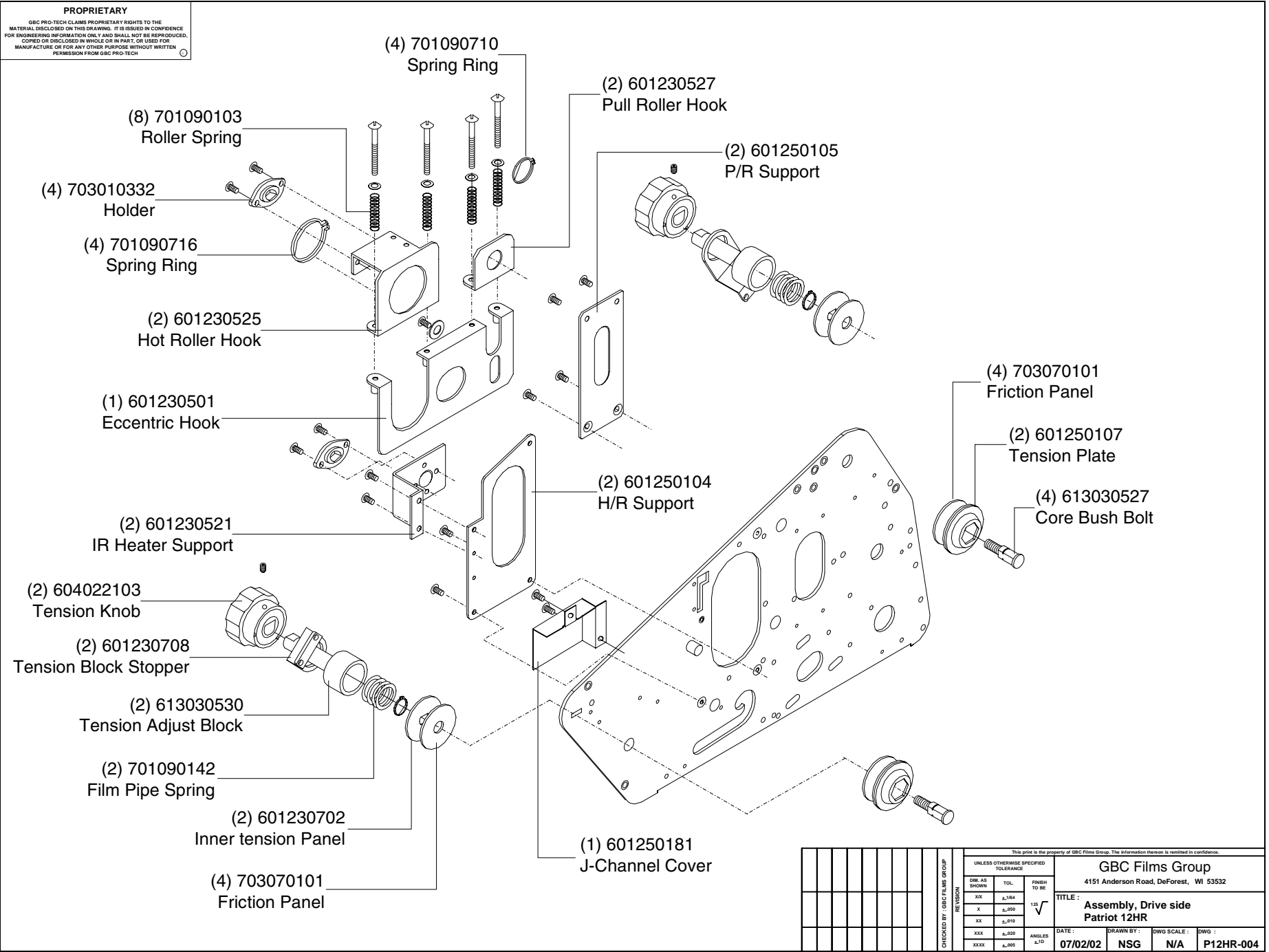

PROPRIETARY
 GBC PRO-TECH CLAIMS PROPRIETARY RIGHTS TO THE MATERIAL DISCLOSED ON THIS DRAWING. IT IS ISSUED IN CONFIDENCE FOR ENGINEERING INFORMATION ONLY AND SHALL NOT BE REPRODUCED, COPIED OR DISCLOSED IN WHOLE OR IN PART, OR USED FOR MANUFACTURE OR FOR ANY OTHER PURPOSE WITHOUT WRITTEN PERMISSION FROM GBC PRO-TECH

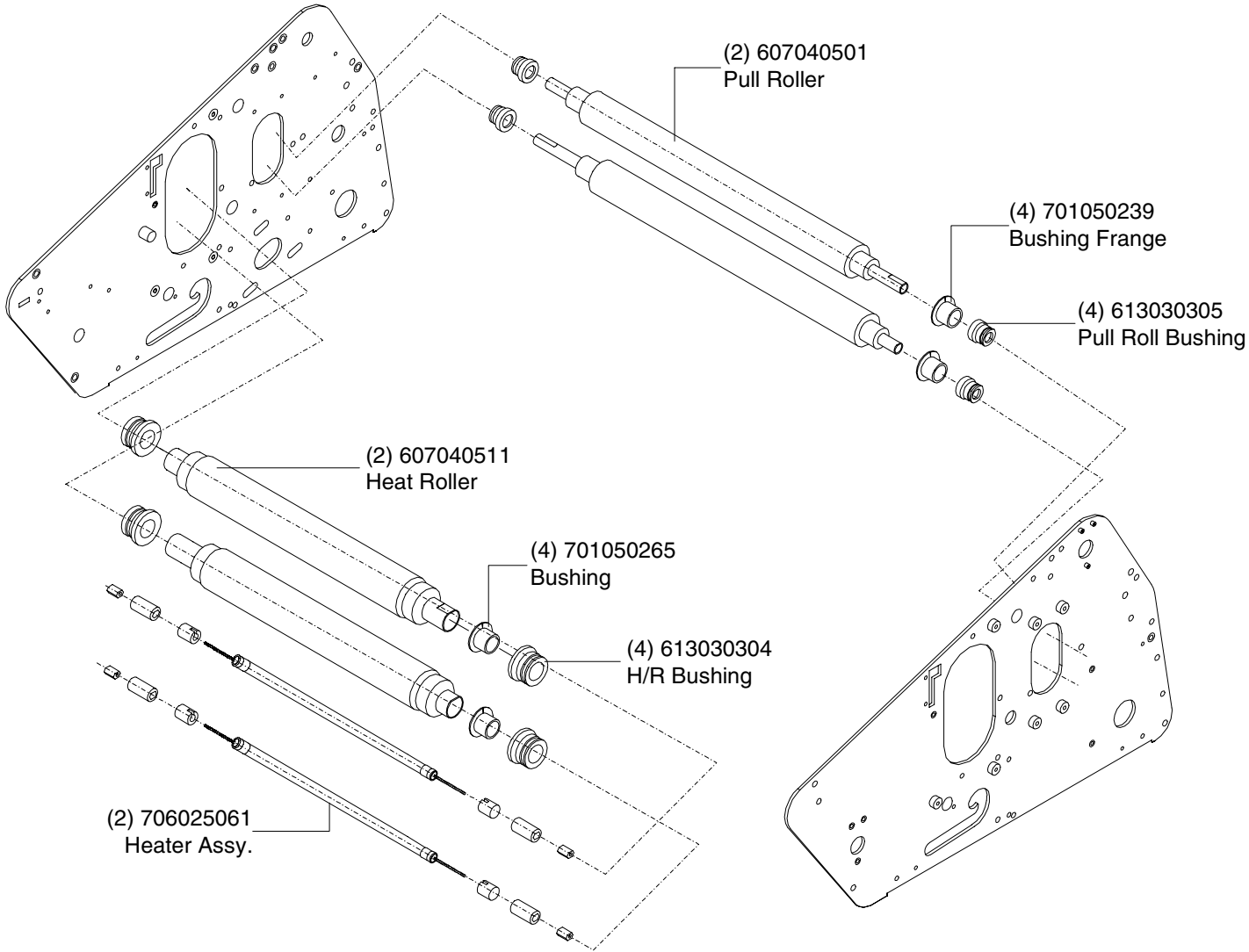

This print is the property of GBC Films Group. The information thereon is limited in confidence.									
UNLESS OTHERWISE SPECIFIED TOLERANCE					GBC Films Group 4151 Anderson Road, DeForest, WI 53532				
DM. AS SHOWN	TOL.	FINISH TO BE	1/2" $\sqrt{\quad}$		TITLE : Assembly, Rollers and heater Patriot 12HR				
XX	$\pm .184$								
X	$\pm .050$								
XX	$\pm .010$								
XX	$\pm .020$								
XX	$\pm .005$	ANGLES 4-10	DATE : 07/03/02	DRAWN BY : NSG	DWG SCALE : N/A	DWG : P12HR-005			
XXXX	$\pm .005$								

PROPRIETARY

GBC PRO-TECH CLAIMS PROPRIETARY RIGHTS TO THE MATERIAL DISCLOSED ON THIS DRAWING. IT IS ISSUED IN CONFIDENCE FOR ENGINEERING INFORMATION ONLY AND SHALL NOT BE REPRODUCED, COPIED OR DISCLOSED IN WHOLE OR IN PART, OR USED FOR MANUFACTURE OR FOR ANY OTHER PURPOSE WITHOUT WRITTEN PERMISSION FROM GBC PRO-TECH

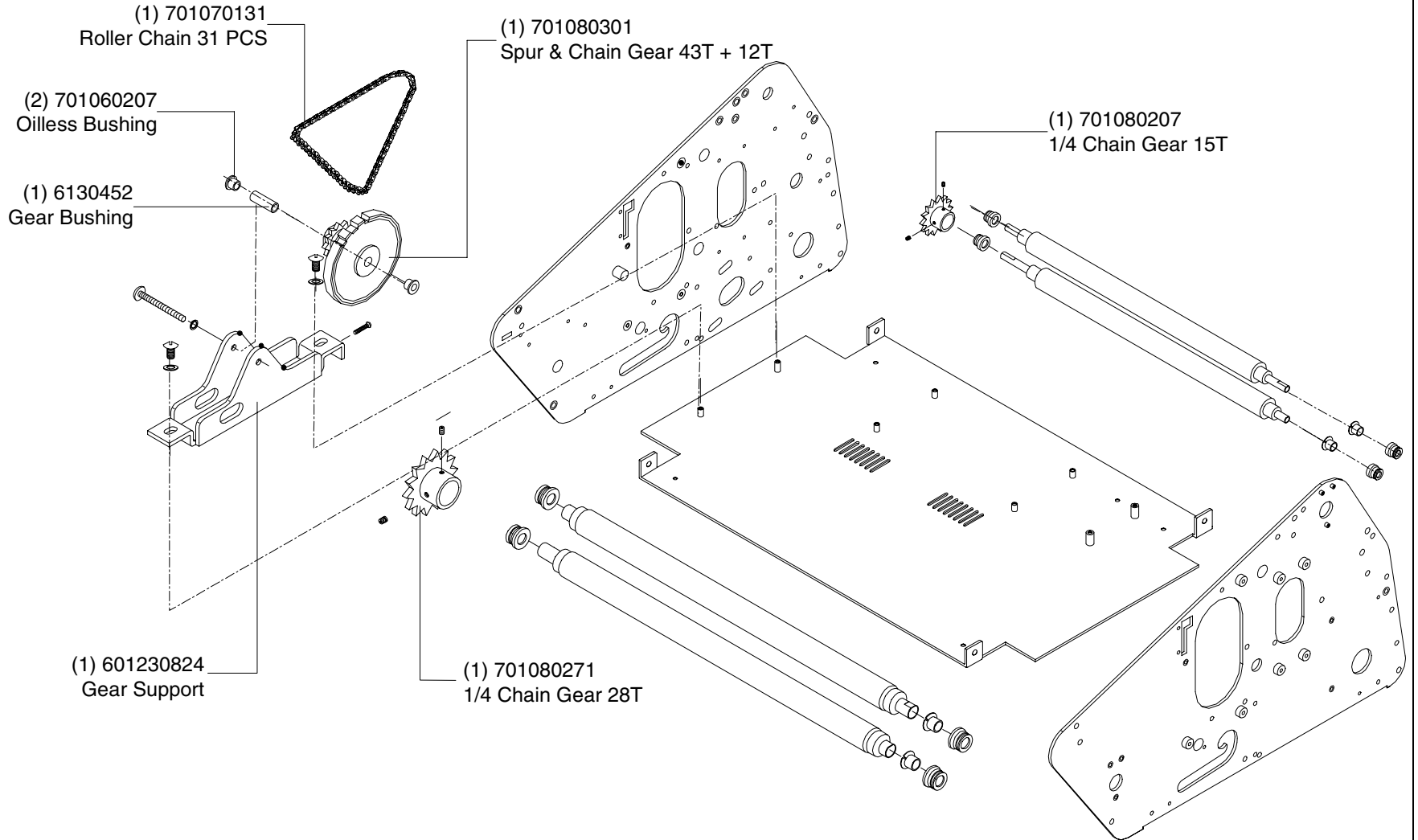

(1) 701070131
Roller Chain 31 PCS

(2) 701060207
Oilless Bushing

(1) 6130452
Gear Bushing

(1) 701080301
Spur & Chain Gear 43T + 12T

(1) 701080207
1/4 Chain Gear 15T

(1) 601230824
Gear Support

(1) 701080271
1/4 Chain Gear 28T

This print is the property of GBC Films Group. The information thereon is limited in confidence.									
UNLESS OTHERWISE SPECIFIED TOLERANCE					GBC Films Group 4151 Anderson Road, DeForest, WI 53532				
DM. AS SHOWN	TOL.	FINISH TO BE	TITLE : Assembly, Drive Patriot 12HR						
XX	±.184	1/2 √							
X	±.050								
XX	±.010								
XXX	±.020	ANGLES 4-10							
XXXX	±.005		DATE : 07/03/02	DRAWN BY : NSG	DWG SCALE : N/A	DWG : P12HR-006			
CHECKED BY : GBC FILMS GROUP	REVISION								

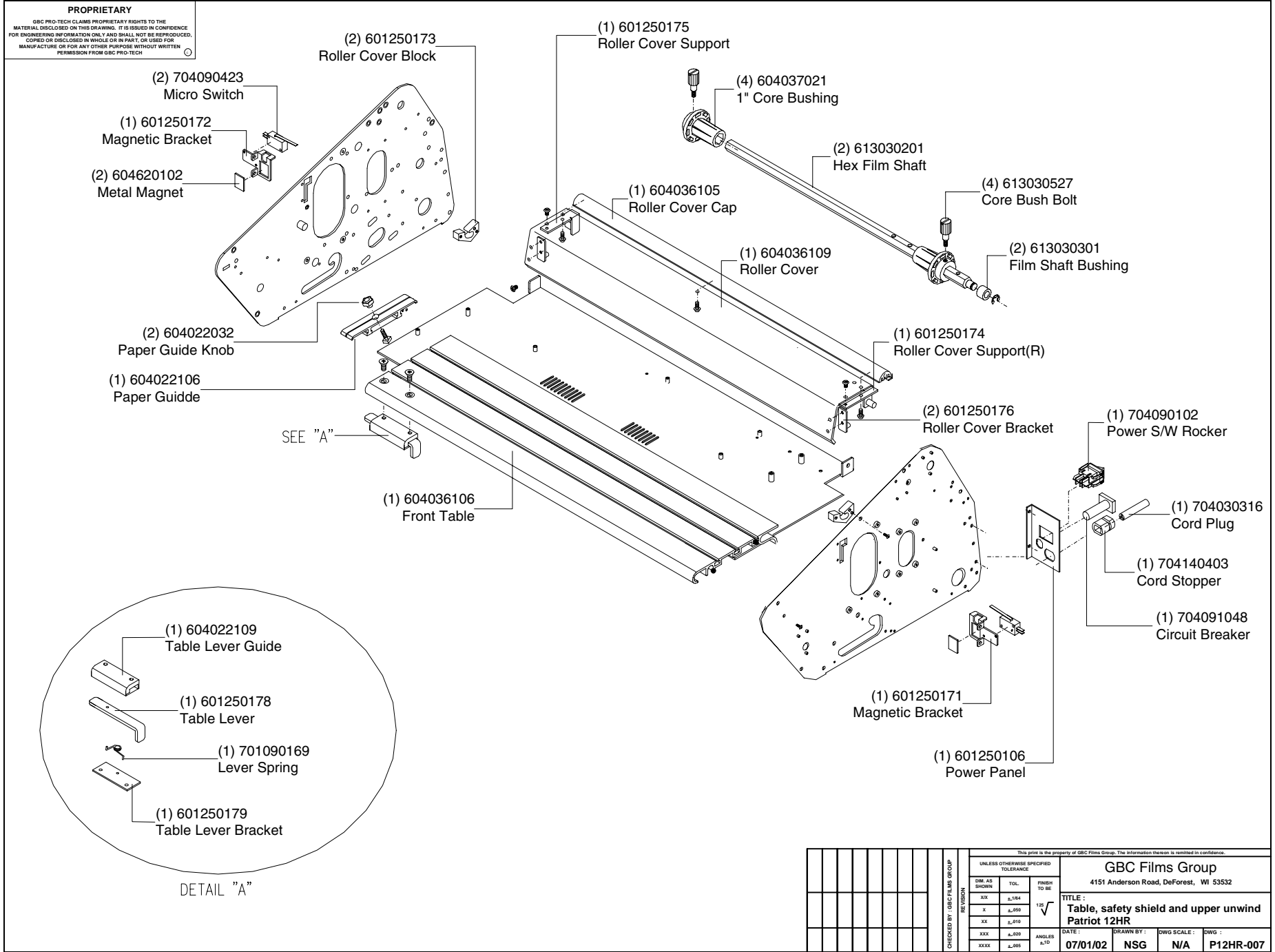

UNLESS OTHERWISE SPECIFIED TOLERANCE				GBC Films Group 4151 Anderson Road, DeForest, WI 53532	
DM. AS SHOWN	TOL.	FINISH TO BE	1/2	TITLE : Table, safety shield and upper unwind Patriot 12HR DATE: 07/01/02 DRAWN BY: NSG DWG SCALE: N/A DWG: P12HR-007	
XX	±.184				
X	±.050				
XX	±.010				
XXX	±.020	ANGLES			
XXXX	±.005	±.0°			

PROPRIETARY

GBC PRO-TECH CLAIMS PROPRIETARY RIGHTS TO THE MATERIAL DISCLOSED ON THIS DRAWING. IT IS ISSUED IN CONFIDENCE, FOR ENGINEERING INFORMATION ONLY AND SHALL NOT BE REPRODUCED, COPIED OR DISCLOSED IN WHOLE OR IN PART, OR USED FOR MANUFACTURE OR FOR ANY OTHER PURPOSE WITHOUT WRITTEN PERMISSION FROM GBC PRO-TECH

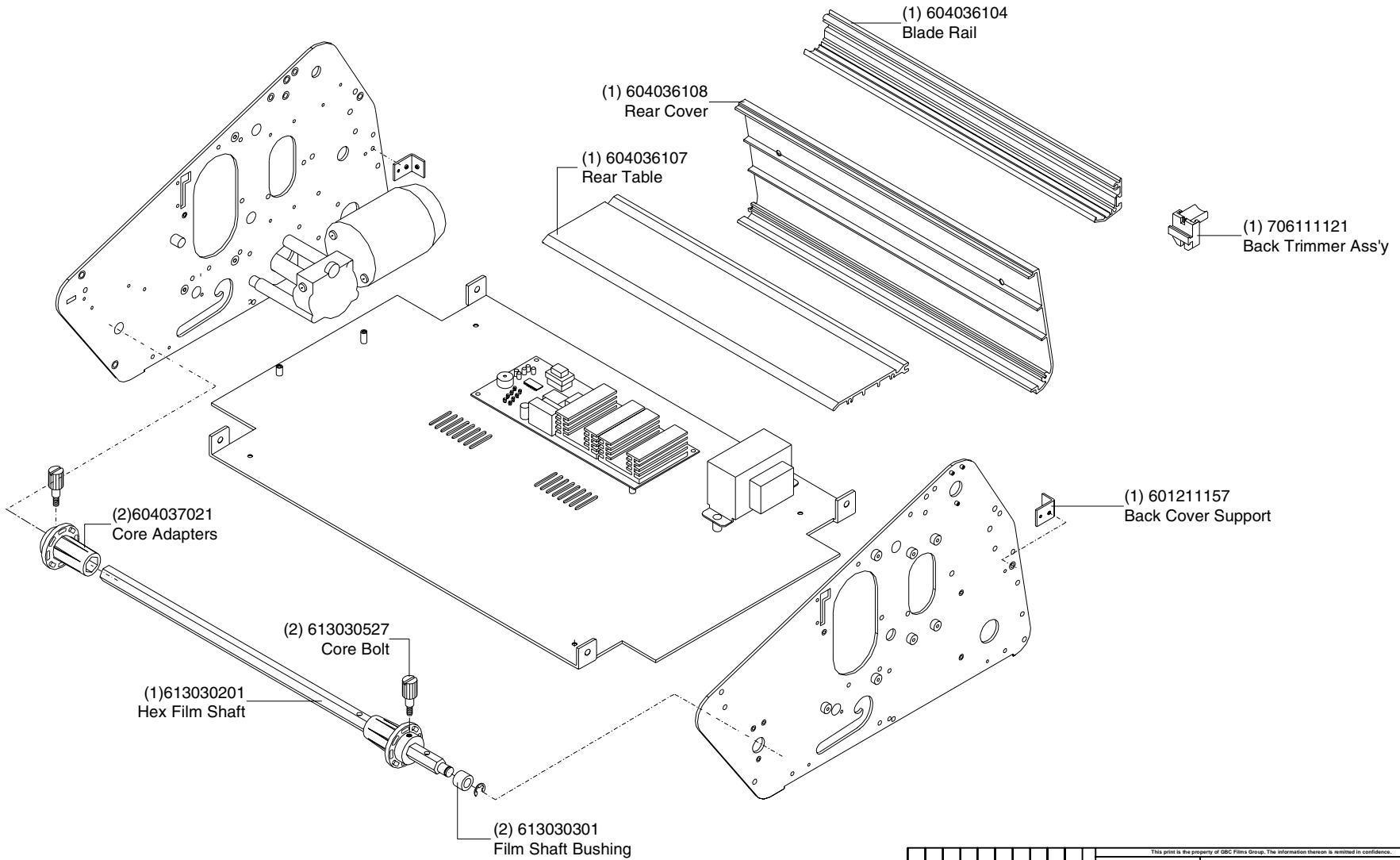

This print is the property of GBC Films Group. The information thereon is restricted in confidence.

UNLESS OTHERWISE SPECIFIED TOLERANCE		GBC Films Group 4151 Anderson Road, DeForest, WI 53532		
DIM. AS SHOWN	TOL.	FINISH TO BE	TITLE: Assembly, Lower unwind & rear table Patriot 12HR	
XX	±.184	125		
X	±.050			
XX	±.010			
XXX	±.020			
REVISION	DATE	DRAWN BY	DWG SCALE	DWG NO.
CHECKED BY: GBC FILMS GROUP	07/01/02	NSG	N/A	P12HR-008

PROPRIETARY
 GBC PRO-TECH CLAIMS PROPRIETARY RIGHTS TO THE MATERIAL DISCLOSED ON THIS DRAWING. IT IS ISSUED IN CONFIDENCE. FOR ENGINEERING INFORMATION ONLY AND SHALL NOT BE REPRODUCED, COPIED OR DISCLOSED IN WHOLE OR IN PART, OR USED FOR MANUFACTURE OR FOR ANY OTHER PURPOSE WITHOUT WRITTEN PERMISSION FROM GBC PRO-TECH

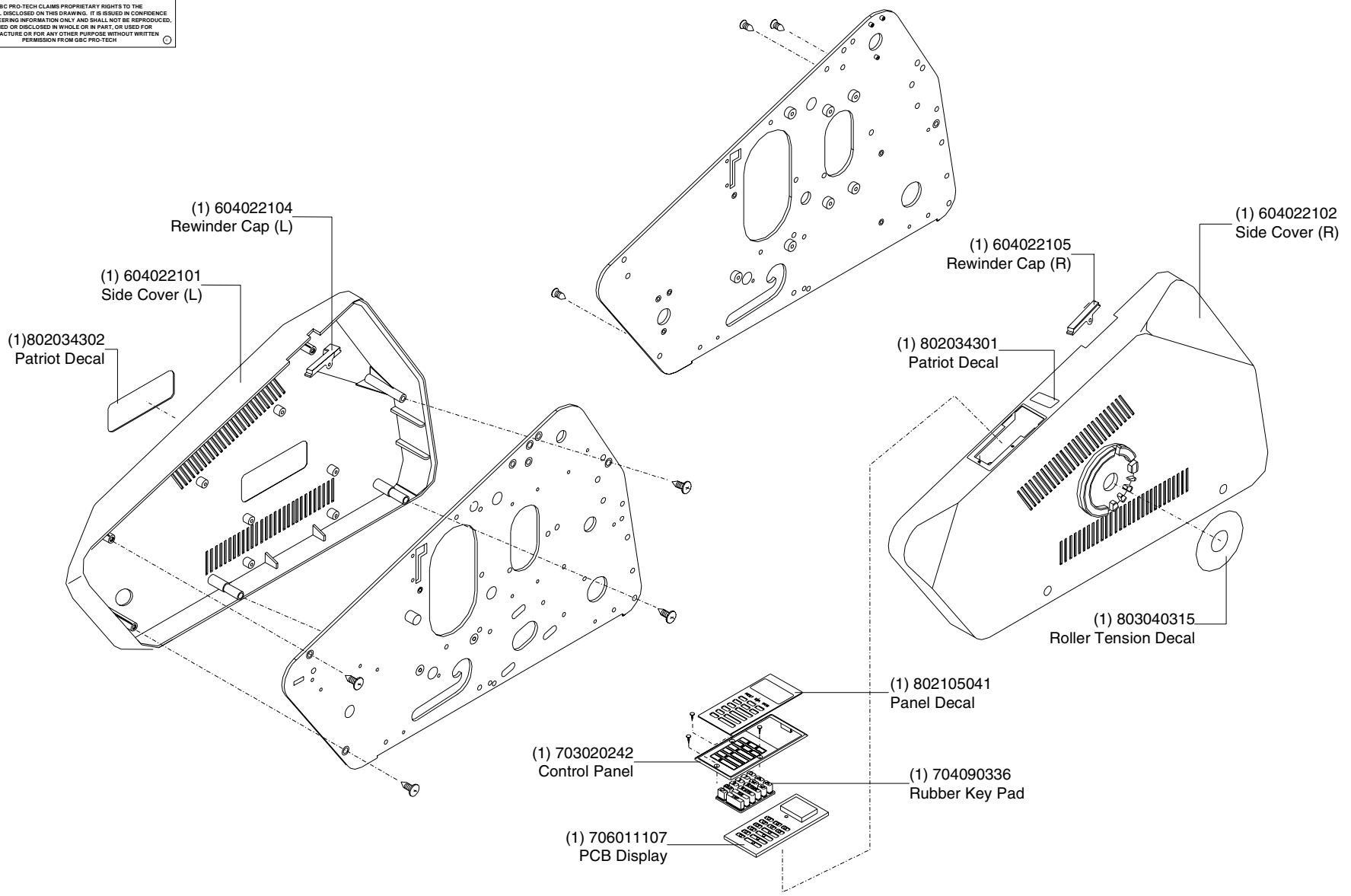

UNLESS OTHERWISE SPECIFIED TOLERANCE				GBC Films Group 4151 Anderson Road, DeForest, WI 53532			
DR. AS SHOWN	TOL.	FINISH TO BE	1/2 √	TITLE: Assembly, Cabinets and panel Patriot 12HR			
XX	±.184			DATE: 07/01/02			
X	±.050			DRAWN BY: NSG			
XX	±.010			DWG SCALE: N/A			
XXX	±.020	ANGLES A-D		DWG: P12HR-009			
XXXX	±.005						

PROPRIETARY

GBC PRO-TECH CLAIMS PROPRIETARY RIGHTS TO THE MATERIAL DISCLOSED ON THIS DRAWING. IT IS ISSUED IN CONFIDENCE FOR ENGINEERING INFORMATION ONLY AND SHALL NOT BE REPRODUCED, COPIED OR DISCLOSED IN WHOLE OR IN PART, OR USED FOR MANUFACTURE OR FOR ANY OTHER PURPOSE WITHOUT WRITTEN PERMISSION FROM GBC PRO-TECH

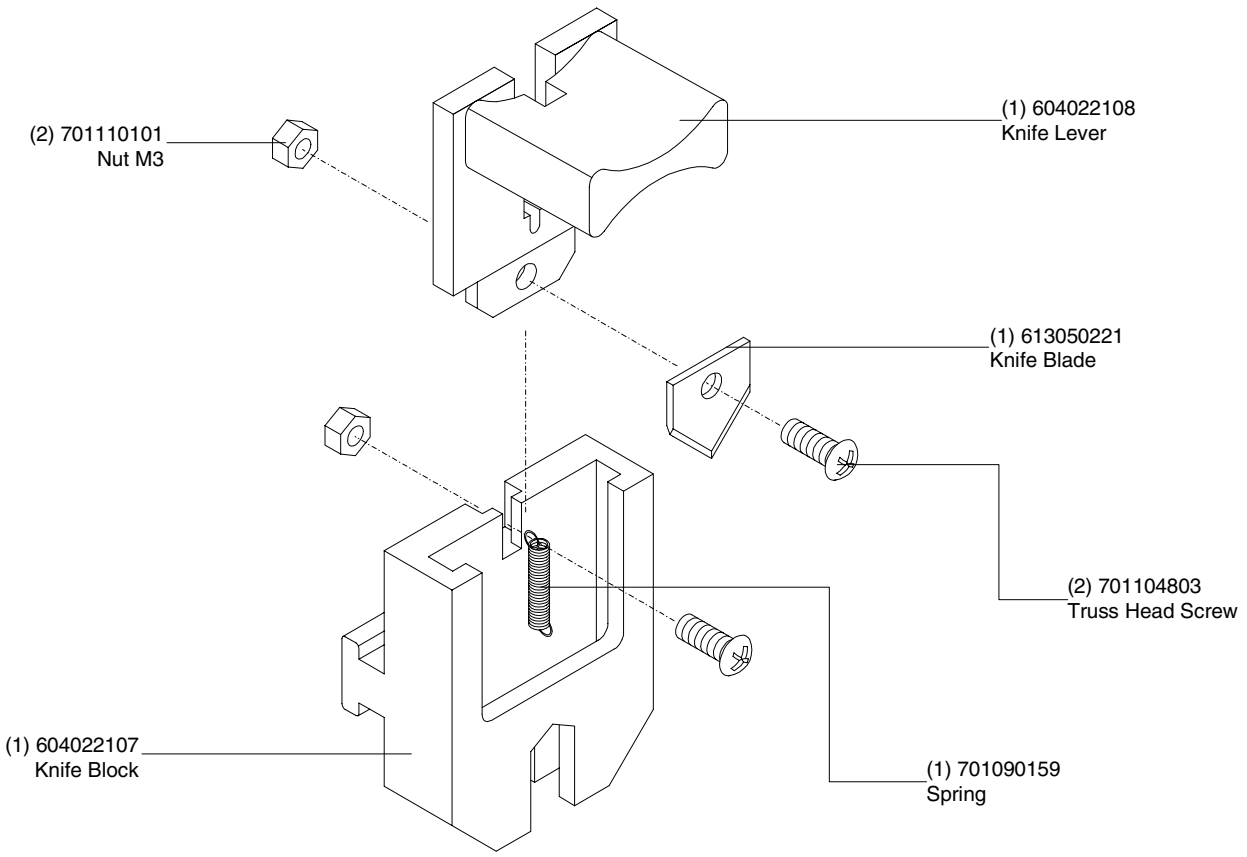

UNLESS OTHERWISE SPECIFIED TOLERANCE				GBC Films Group 4151 Anderson Road, DeForest, WI 53532			
DR. AS SHOWN	TOL.	FINISH TO BE		TITLE : Assembly, slitter			
X/2	±.184	125	√	DATE : 07/01/02			
X	±.050			DRAWN BY : NSG			
XX	±.010			DWG SCALE : N/A			
XXX	±.020	ANGLES		DWG : 706111121			
XXXX	±.005	±10					