

DIGITAL FEEDER OPERATION & MAINTENANCE MANUAL

© February 2000 GBC Pro-Tech

Do not duplicate without written permission.

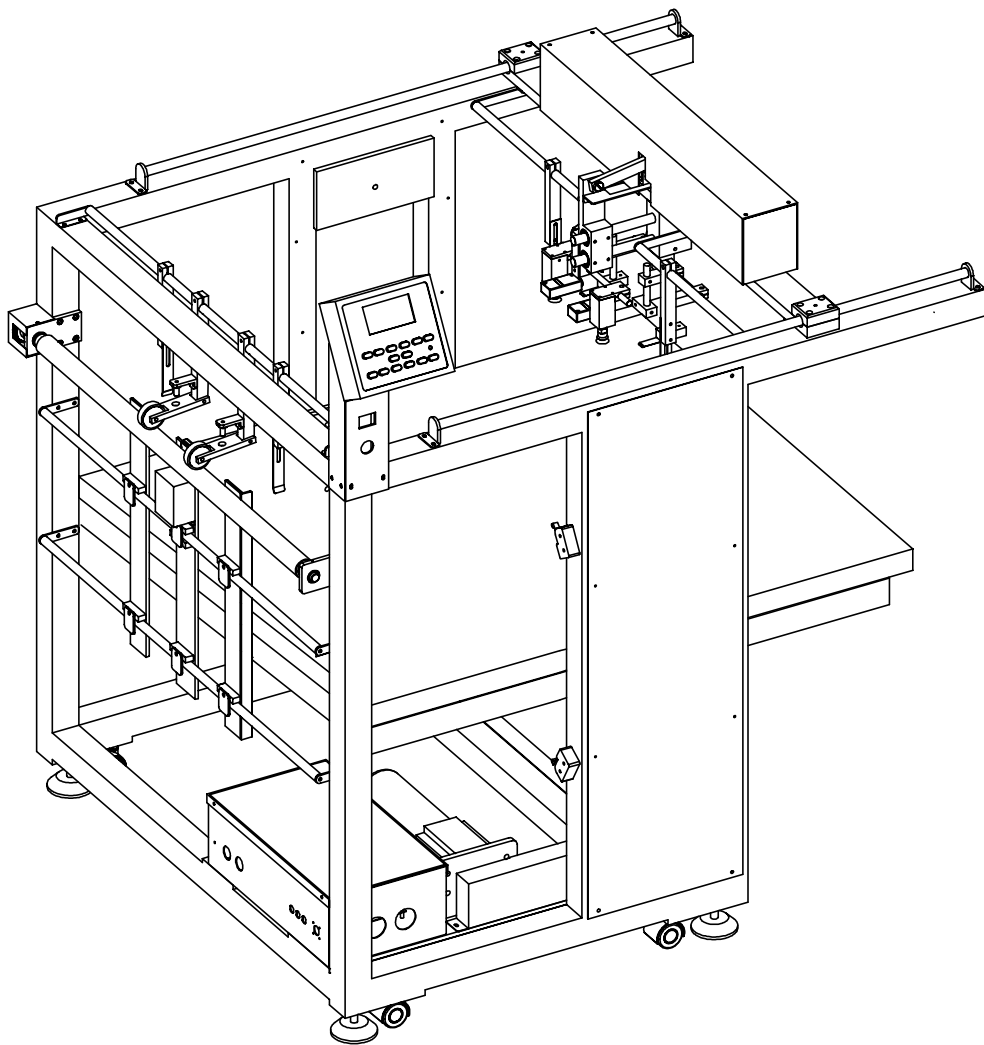

Revision :
Part number : 930 - 042

GBC Pro - Tech
4151 Anderson Road
DeForest, WI 53532
Ph: (608) 246 - 8844
Fx: (608) 246 - 8645







Read Me File

The information in this publication is provided for reference and is believed to be accurate and complete. GBC Pro - Tech is not liable for errors in this publication or for incidental or consequential damage in connection with the furnishing or use of the information in this publication, including, but not limited to, any implied warranty of fitness or merchantability for any particular use.

GBC Pro - Tech reserves the right to make changes to this publication and to the products described in it without notice. All specifications and information concerning products are subject to change without notice.

Reference in this publication to information or products protected by copyright or patent does not convey any license under the rights of GBC Pro - Tech or others. GBC Pro - Tech assumes no liability arising from infringements of patents or any other rights of third parties.

This publication is copyrighted © 2000 by GBC Pro - Tech. All rights reserved. The information contained in this publication is proprietary and may not be reproduced, stored, transmitted, or transferred, in whole or in part, in any form without the prior and express written permission of GBC Pro - Tech.

The following information will explain how to move around within the electronic version of this publication. The hand will change to a pointer finger identifying hyperlinked areas. When moving from page to page, use  to return to the **first PAGE**, use  to advance to the **last PAGE**, use  to **go back one PAGE** and use  to **advance one PAGE**. When moving from view to view, use  to **return** to a previous **VIEW** and use  to **advance** to the next **VIEW**.

Should you find an error within this publication or would like to make a suggestion, please utilize the fax correspondence sheet following the Read Me file and fax it to the number provided. Your comments and help will ensure up to date information. Thank you.

This page intentionally left blank.

Fax Correspondence

Fax number : (608) 246 - 8645

Date : _____

To : Sean Flood @ GBC Pro - Tech
4151 Anderson Road
DeForest, WI 53532

From : _____

Company : _____

Address : _____

Phone number : (_____) _____ Fax number : (_____) _____

Re : Digital Feeder Operations and Maintenance Manual (930 - 042)

Section #: _____ Page #: _____

Correction (s): _____

Additional comments: _____

This page intentionally left blank.

Table of Contents

Section 1: Safety

1.1 Symbols1 - 1

1.2 Safety features1 - 1

1.3 Installation1 - 3

1.4 Operations1 - 8

1.5 Getting started1 - 9

1.6 Troubleshooting1 - 10

1.7 Maintenance1 - 11

1.8 Label locations1 - 12

 Figure 1.8.1 Label Location1 - 13

Section 2: Warranty

2.1 Limited warranty information2 - 1

2.2 Exclusions to the warranty2 - 1

Section 3: Specifications

3.1 General	3 - 1
3.2 Consumables	3 - 1
3.3 Function	3 - 2
3.4 Electrical	3 - 2
3.5 Dimensions	3 - 3
Figure 3.5.1 Digital Feeder	3 - 4
Figure 3.5.2 Conveyor	3 - 5

Section 4: Installation

4.1 Pre-installation check list	4 - 1
Figure 4.1.1 Suggested floor layout	4 - 2
Figure 4.1.2 Optional cutter manual	4 - 3
4.2 Know your machine	4 - 4

4.3 Unpacking4 - 5

4.4 Shrink wrapped4 - 6

4.5 Crated4 - 7

4.6 Set up4 - 9

4.7 Leveling4 - 13

4.8 Connections4 - 15

4.9 Safety check4 - 18

4.10 Control panel check4 - 23

Section 5: Operations

5.1 Control panel5 - 1

 Figure 5.1.2 Control panel5 - 5

5.2 Emergency5 - 6

5.3 Job programming5 - 8

Section 6: Getting started

6.1 Loading the sheet stack	6 - 1
6.2 Adjusting the guides	6 - 2
6.3 Making the adjustments	6 - 5
6.4 Setting the controls	6 - 6

Section 7: Troubleshooting

7.1 Troubleshooting guide	7 - 1
7.1.1 Troubleshooting guide chart	7 - 2

Section 8: Maintenance

8.1 Maintenance schedule	8 - 1
8.2 Clean the cabinets and covers	8 - 2

8.3 Cleaning the control panel8 - 3

8.4 Emptying the water trap8 - 3

This page intentionally left blank.

Section 1 Safety



CAUTION

Do not attempt to operate your Digital Feeder until you have read this section carefully!

Your safety, as well as the safety of others, is important to GBC Pro - Tech. This section contains important safety information.

The following symbols are used throughout this manual to indicate **Information**, **Caution**, **Warning**, **Danger** and **Electrical Shock** conditions.

1.1 Symbols



INFORMATION

Indicates helpful information that should be considered before, during, or after an action, step or procedure is given.



CAUTION

Indicates a potentially hazardous situation which, if not avoided, could result in minor or moderate injury, or alerts against unsafe practices or alerts against actions which could damage the product.



WARNING

Indicates a potentially hazardous situation which, if not avoided, could result in serious injury.



DANGER

Indicates an imminently hazardous situation which, if not avoided, could result in death or serious injury.



ELECTRICAL SHOCK

Indicates an electrical shock situation which, if not avoided, could result in serious paralysis of the body or death.

1.2 Safety features

The Digital Feeder has been designed with safety as a primary consideration; however, you must become thoroughly familiar with the controls, proper operation, proper service procedures and safety features of the machine before using or servicing the unit.



INFORMATION

Only a qualified service technician should perform any procedure requiring the cabinet covers to be removed.



DANGER

At no time should you attempt to override any of the safety devices on the machine.

The word qualified is defined below;

Qualified ;

- Any engineer that has experience with electrical and mechanical design of lamination equipment. The engineers should be fully aware of all aspects of safety with regards to lamination equipment.

- Any commissioning or service engineer must be of competent nature, trained and qualified to GBC Pro-Tech standards to fulfill that job. This person will have completed and passed the full service training course from GBC Pro-Tech.

- Any GBC Technician, GBC Specialist, and / or GBC Pro-Tech Technician that has been through the GBC Pro-Tech service training course.

An important feature of the Digital Feeder is the emergency stop and limit switches. Refer to **Figure 1.2.1**

Figure 1.2.1 Safety devices

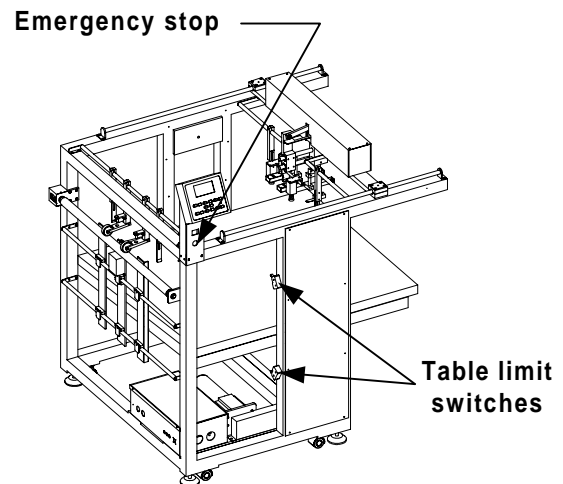

To engage the **EMERGENCY STOP** feature, push in. This will remove power to the feeder motors.

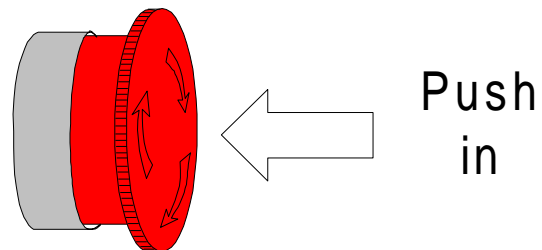

To continue operation, the **E-STOP** must be in the unlatched position. To reset the **E-STOP**, twist 1/4 turn clockwise.

Rotate

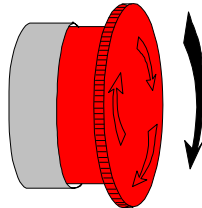

1.3 Installation

The following symbols are positioned at various points in **Section 4 Installation**.



CAUTION

Failure to follow the pre-installation check list can result in damage to the cutter.



INFORMATION

The E-STOP on the Explorer 107 will stop the feeder. The E-STOP on the feeder will not stop the Explorer 107.



WARNING

The Digital Feeder is a large and heavy piece of equipment. It is necessary to employ **LICENSED RIGGERS ONLY** to move the machine. The machine is not designed to be tipped up or sideways in any way. Such action disturbs the exact alignment of the moving parts of the machine and requires extensive realignment. You can be crushed or seriously injured.



INFORMATION

The feeder will only operate if the Explorer 107 is running and the sheet stack limit switch is engaged.



INFORMATION

If you have a GBC Digital Cutter inline with the feeder and laminator, refer to Figure 4.1.2 Optional cutter layout

**INFORMATION**

ALL SHIPMENTS ARE EX-WORKS. At our dock, title passes to the buyer. Please review your insurance coverage prior to shipment, as you are responsible for all subsequent freight charges and risks.

**INFORMATION**

Claims for shipping damages must be handled between your insurance company and the shipping company.

**INFORMATION**

Before signing the Bill of Lading, you should inspect the crate and / or pallet for signs of damage or missing items; if applicable, make note of this on the Bill of Lading.

**CAUTION**

Do not use an open blade to cut the shrink wrap from the machine. You can cause damage to the equipment!

**INFORMATION**

The shrink wrap is not recyclable, therefore it must be discarded.

**INFORMATION**

Depending on the destination and customer preference, the Digital Feeder may be shipped by various methods. The machine may arrive shrink wrapped or in a plywood crate on a skid. Please follow the unpacking procedure that pertains to your method of shipment.

**WARNING**

Do not attempt to move the Digital Feeder across anything other than a flat level surface. You can be crushed or seriously injured.

**WARNING**

The unpacking process requires at least two people. You can be severely injured, crushed or cause damage to the equipment.

**CAUTION**

Do not allow the top to fall into the crate. It can damage the feeder.



INFORMATION

Do not put packing screws on the floor. They can cause problems when trying to roll the feeder into position or you can become injured if stepped on.



CAUTION

Do not use a knife or other sharp objects to remove the strapping / ties from around the machine. You can cause damage to the equipment.



CAUTION

A second person must support the side labeled 5 in Figure 4.5.1 It can fall and damage the Feeder or cause harm to you and others.



WARNING

Always use safe and proper lifting practices when lifting heavy objects. You can become seriously injured or crushed.



INFORMATION

The crate components can be reused for shipping the machine again or may be disassembled and recycled.



CAUTION

Do not stand the conveyor on its side. Lay the conveyor flat on the floor. You can cause damage to the equipment!



INFORMATION

GBC Pro-Tech's warranty does not cover malfunction of the equipment due to mishandling and / or tipping. GBC Pro-Tech bears no responsibility for personal injury or damage due to moving the feeder improperly.



WARNING

Caution should always be exercised when using the laminator with the safety shields raised. You can be seriously HURT or INJURED!



INFORMATION

The Explorer 107 pressure plate will not be used in conjunction with the Digital Feeder.



INFORMATION

Both ends of the encoder cable are identical.



INFORMATION

The Explorer 107 feed table will not be used in conjunction with the Digital Feeder.



INFORMATION

Do not pinch the pneumatic tubing when using zip ties to route. Pinching will constrain the air flow.



INFORMATION

Improper leveling, will result in poor output quality.



WARNING

Do not wear ties, loose fit clothing or dangling jewelry while operating or servicing the feeder. These items can get caught in the machine and choke you or you can be crushed.



INFORMATION

One person will read the level while the other person makes the necessary adjustments.



WARNING

If a safety feature is not functioning properly, contact your local service representative immediately



INFORMATION

The JUN-AIR compressor will not work for the feeder due to lack of air volume.



INFORMATION

The Explorer 107 and the Digital Feeder must both have power turned to ON.

**INFORMATION**

Ensure no E-STOP is depressed.

**INFORMATION**

The Explorer 107 E-STOPS will stop the feeder. Once the upper pull roller is engaged and turning, the feeder will resume running.

**WARNING**

Keep hands and feet away from the sheet table when raising or lowering. You may be crushed!

**INFORMATION**

The feeder will only operate if the Explorer 107 is running and the sheet stack limit switch is engaged.

**INFORMATION**

Explorer 107: Ensure no E-STOP is depressed and the front safety shield is in the fully closed and locked position.

**INFORMATION**

Refer to Section 5.3 Job programming to store parameters.

**INFORMATION**

The encoder is attached to the upper pull roller on the Explorer 107.

**INFORMATION**

The encoder on the Explorer 107 sets the speed of the feeder to match.

1.4 Operations

The following symbols are positioned at various points in **Section 5 Operations**.



WARNING

Do not wear ties, loose fit clothing or dangling jewelry while operating or servicing the feeder. These items can get caught in the machine and choke you or you can be crushed.



INFORMATION

If the vacuum is ON and OFF is pressed under RUN, vacuum will stop.



INFORMATION

If vacuum is ON and OFF is pressed under RUN, the feeding head unit will stop at its current position.



INFORMATION

Vacuum ON will only operate if RUN is ON.
Vacuum ON can be pressed to simultaneously engage with RUN ON



INFORMATION

When vacuum OFF is pressed, the feeding head unit will complete its cycle before stopping.



INFORMATION

Refer to Section 5.3 Job programming to store parameters.



WARNING

Keep hands and feet away from the sheet table when raising or lowering.
You may be crushed!



INFORMATION

The E-STOP on the Explorer 107 will stop the feeder. The E-STOP on the feeder will not stop the Explorer 107.

1.5 Getting started

The following symbols are positioned at various points in **Section 6 Applications**.



WARNING

Do not wear ties, loose fit clothing or dangling jewelry while operating or servicing the feeder. These items can get caught in the machine and choke you or you can be crushed.



INFORMATION

The feeder will only operate if the Explorer 107 is running and the sheet stack limit switch is engaged.



INFORMATION

All E-STOPS (Feeder and Explorer 107) must be in the unlatched position.



INFORMATION

A minimum sheet stack height of 3 in. (7.6 cm) is required for loading.



INFORMATION

This will allow you to adjust the belts without feeding web through the laminator.



WARNING

Inform persons around the machine that your hands are in the laminator.



INFORMATION

The belts will only move if the upper pull roller on the Explorer 107 is turning.



INFORMATION

All five belts should fall within the width of the sheet.

**INFORMATION**

The sheet blower should fan approximately 12 - 15 sheets. Varies due to paper weight.

**INFORMATION**

For heavy paper use more spring pressure. For lighter paper use less spring pressure.

**INFORMATION**

The feeder will start when the laminator starts.

1.6 Troubleshooting

The following symbols are positioned at various points in **Section 7 Troubleshooting**.

**WARNING**

Do not wear ties, loose fit clothing or dangling jewelry while operating or servicing the feeder. These items can get caught in the machine and choke you or you can be crushed.

**DANGER**

At no time should remove any covers or panels in an attempt to perform repairs or adjustments.

**DANGER**

At no time should you attempt to override any of the limit switches.

**ELECTRICAL SHOCK**

Do not remove the cabinet covers. You can be severely shocked or killed!

1.7 Maintenance

The following symbols are positioned at various points in **Section 8 Maintenance**.



DANGER

At no time should remove any covers or panels in an attempt to perform repairs or adjustments.



WARNING

Do not wear ties, loose fit clothing or dangling jewelry while operating or servicing the feeder. These items can get caught in the machine and choke you or you can be crushed.



ELECTRICAL SHOCK

Remove power from the feeder before cleaning. You can be severely shocked, killed or cause a fire.



INFORMATION

Improper maintenance, can result in poor output quality.



ELECTRICAL SHOCK

Do not use liquid or aerosol cleaners on the feeder. Do not spill liquid of any kind on the feeder. You can be severely shocked, killed or cause a fire. Use only a damp cloth for cleaning unless other wise specified.



INFORMATION

Below is a recommended maintenance schedule. Before performing any of the steps listed, read through the procedures first. Please follow the instructions pertaining to the step you are performing.



ELECTRICAL SHOCK

Do not use liquid or aerosol cleaners on the feeder. Do not spill liquid of any kind on the feeder. You can be severely shocked, killed or cause a fire. Use only a damp cloth for cleaning unless other wise specified.

1.8 Label locations

Posted at various locations on the Digital Feeder are important safety labels. **Pay careful attention to these labels at all times!** Figure 1.8.1 illustrates the location of each of these labels.

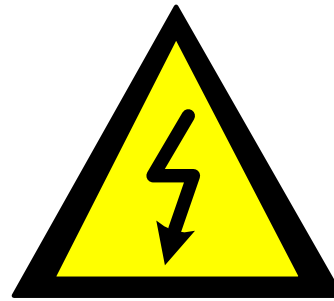

(1) Voltage: High voltage components. Do not remove cover.

▲ MUCHO CUIDADO	▲ MUCHO CUIDADO		▲ WARNING	▲WAARSCHUWING	▲ ATTENZIONE	▲ WARNING
Riesgo de choque eléctrico. No abra. Adentro, no hay piezas reparables para el usuario. Mantenimiento solamente para personal calificado.	Risque de escasse électrique. Ne pas ouvrir. Pas de pièces réparables par l'utilisateur. Entréten par personnel qualifié.		Electrical shock hazard. Do not open. No user serviceable parts inside. Refer servicing to qualified service personnel.	Kans op elektrische shock. Niet openen. Bevat geen door gebruik te repareren onderdelen. Door bevoegd service personeel laten repareren.	Pericolo di scossa elettrica. Nessuna parte riparabile dall'utente. Chiamare un servizio di riparazioni qualificato.	Spannungsfeldern de Teile. Nicht öffnen. Entsch keine vom Endverbraucher zu wählend Teile. Für service bitte an qualifiziertes Service-Personal wenden.

(2) ELECTRICAL SHOCK: Electrical shock hazard. Electrical voltage behind panel.

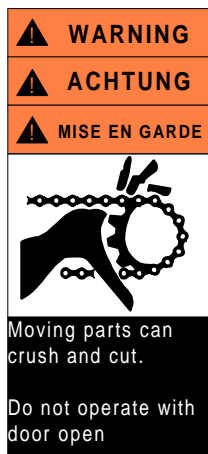

(2) CRUSH and CUT: Moving parts. Keep hands away. Do not remove cover.

Figure 1.8.1 Label locations

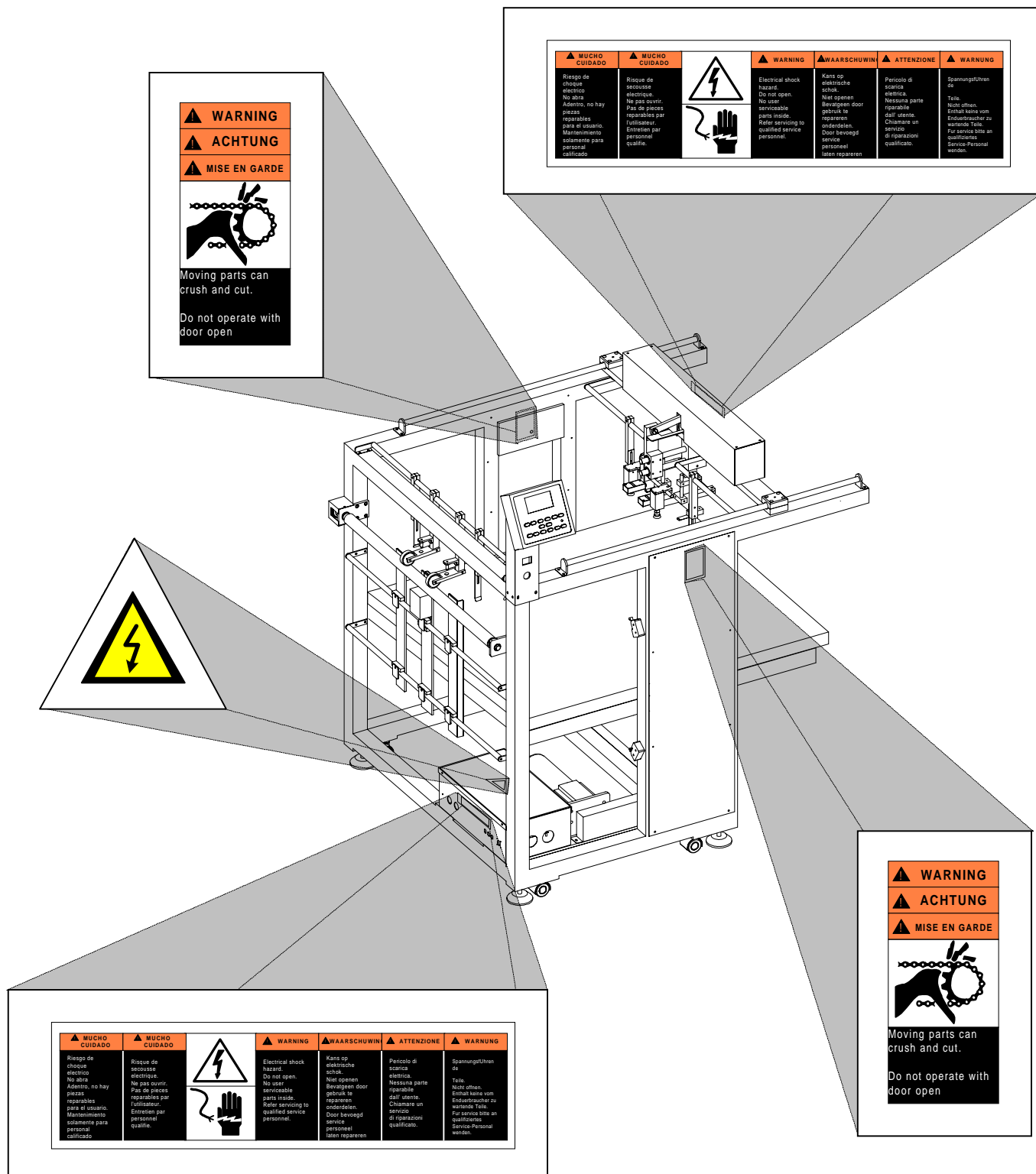

This page intentionally left blank.

Section 2 Warranty

GBC Pro-Tech warrants the equipment sold is free from defects in material and workmanship for a period of **one (1) year parts and 90 days labor** from the date of installation. This warranty is the only warranty made by GBC Pro-Tech and cannot be modified or amended.

GBC Pro-Tech's sole and exclusive liability and the customer's sole and exclusive remedy under this warranty shall be, at GBC Pro-Tech's option, to repair or replace any such defective part or product. These remedies are only available if GBC Pro-Tech's examination of the product discloses to GBC Pro-Tech's satisfaction that such defects actually exist and were not caused by misuse, neglect, attempt to repair, unauthorized alteration or modification, incorrect line voltage, fire, accident, flood or other hazards.

2.1 Limited Warranty

This warranty specifically does not cover damage to the belts caused by knives, razor blades, other sharp objects or improper use of the machine. **Warranty repair or replacement does not extend the warranty beyond the initial one year period from the date of delivery.**



CAUTION

Unauthorized customer alterations will void this warranty.

THE WARRANTY MADE HEREIN IS IN LIEU OF ALL OTHER WARRANTIES, EXPRESS OR IMPLIED, INCLUDING ANY WARRANTY OR MERCHANTABILITY OR FITNESS FOR A PARTICULAR PURPOSE. GBC PRO-TECH WILL NOT BE LIABLE FOR PROPERTY DAMAGE OR PERSONAL INJURY (UNLESS PRIMARILY CAUSED BY ITS NEGLIGENCE), LOSS OF PROFIT OR OTHER INCIDENTAL OR CONSEQUENTIAL DAMAGES ARISING OUT OF THE USE OR INABILITY TO USE THE EQUIPMENT.

2.2 Exclusions to the Warranty

This warranty specifically does not cover;

- 1. Damage to the belts caused by knives, razor blades or other sharp objects.**
- 2. Damage to the machine caused by lifting, tilting and/or any attempt to position the machine other than rolling on the installed castors on even surfaces.**
- 3. Improper use of the machine.**
- 4. Damage due from unqualified person(s) servicing the machine.**

Qualified

- Any engineer that has experience with electrical and mechanical design of lamination equipment. The engineers should be fully aware of all aspects of safety with regards to lamination equipment.

- Any commissioning or service engineer must be of competent nature, trained and qualified to GBC Pro-Tech standards to fulfill that job. This person will have completed and passed the full service training course from GBC Pro-Tech.

- Any GBC Technician, GBC Specialist, and/or GBC Pro-Tech Technician that has been through the GBC Pro-Tech service training course.

Section 3: Specifications

Specifications provide all of the technical data for the Digital Feeder.

3.1 General

Description:

- An efficient and self dependent feeding system to accompany the high speed Explorer 107 Laminator..

Features:

- Interactive operation LCD module control panel
- Automatic adjusted speed control
- Vacuum head is driven by a stepper motor
- All functions are controlled by microprocessors
- 9 programmable job memory locations
- Sheet sizes and gap are displayed
- Vacuum head can be independently adjusted

Operations:

- Automatic feeding

3.2 Consumables

Sheet sizes:

- 8.5 in. x 11 in. to 30 in. x 40 in.
(22 cm x 28 cm to 76 cm x 102 cm)

Sheet thickness:

- 24 lb. bond to 12 pt. cover stock

Pile weight: • 800 lbs Maximum (362 kgm)

Pile height: • 3 in. minimum (7.6 cm)
• 14 in. maximum (35.6 cm)

3.3 Function

Speed: • Equal to the laminator

Motor: • 1/2 horse power drive motor
• Bi-directional D.C. motor

Control: • Left side mounted control panel

3.4 Electrical

United States: • 110 VAC, 60 Hz, single phase, 10 amps.

Europe: • 220 - 240 VAC, Wye 3 phase, 3 amps/ phase

Wattage consumption: • 805 watts

Amperage draw: • Drive motor = 7amps

D/C Voltage used: • 24 vdc

3.5 Dimensions

Weight:

- Crated : 350 lbs. (159 kg.)
- Uncrated : 200 lbs. (91 kg.)

Dimensions

Crated:

- 62 in. (L) x 48 in. (W) x 63 in. (H)
(157 cm (L) x 122 cm (W) x 160 cm (H))

Uncrated:

Feeder with conveyor:

- 54.5 in. (H) x 39.5 in. (W) x 97 in. (L)
(138 cm (H) x 100 cm (W) x 246 cm (L))

Feeder unit:

- 54.5 in. (H) x 39.5 in. (W) x 47.25 in. (L)
(138 cm (H) x 100 cm (W) x 120 cm (L))
Refer to **Figure 3.5.1 Digital Feeder**

Conveyor:

- 8.5 in. (H) x 34.5 in. (W) x 51 in. (L)
(22 cm (H) x 88 cm (W) x 130 cm (L))
Refer to **Figure 3.5.2 Conveyor**

Figure 3.5.1 Digital Feeder

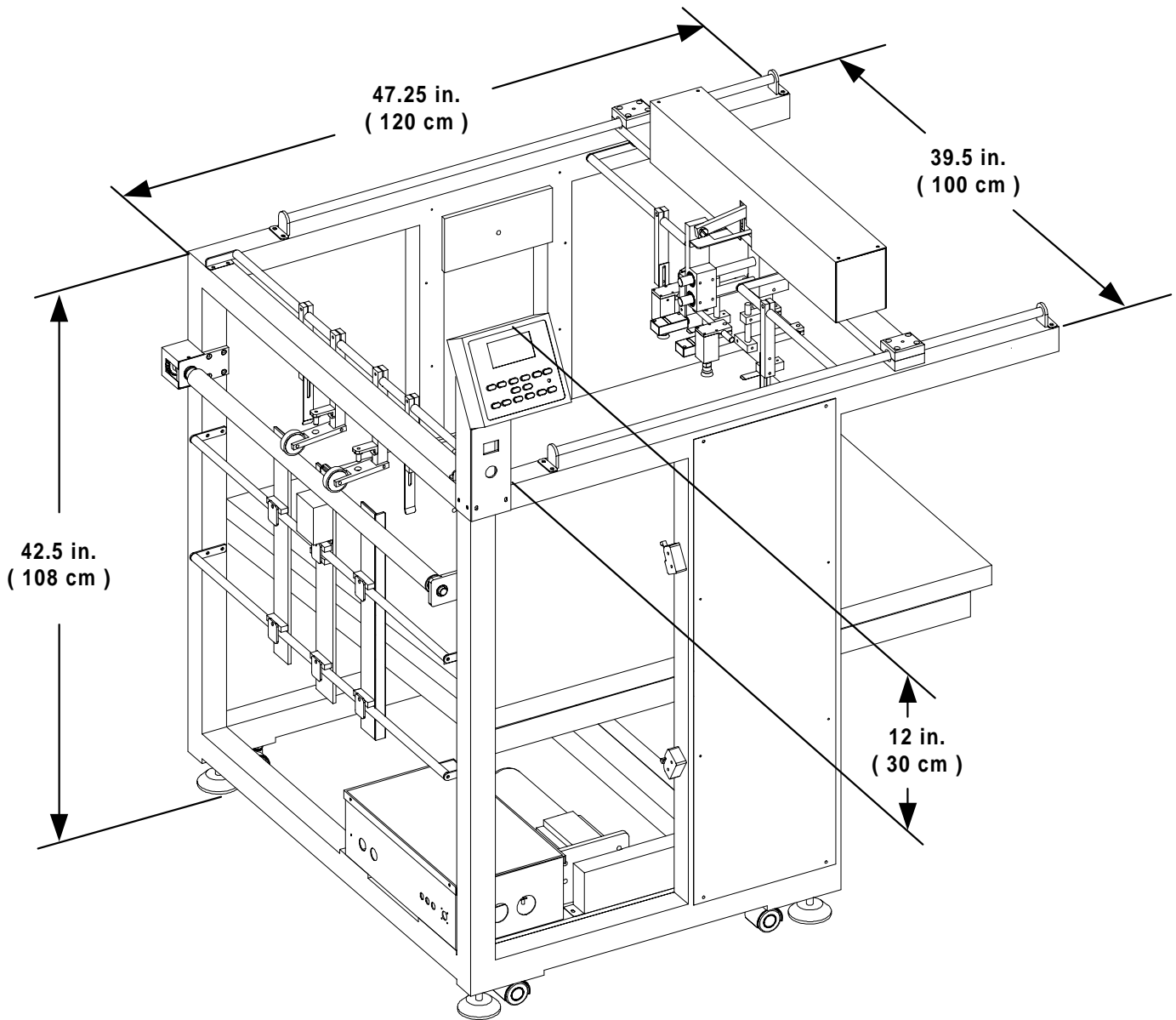
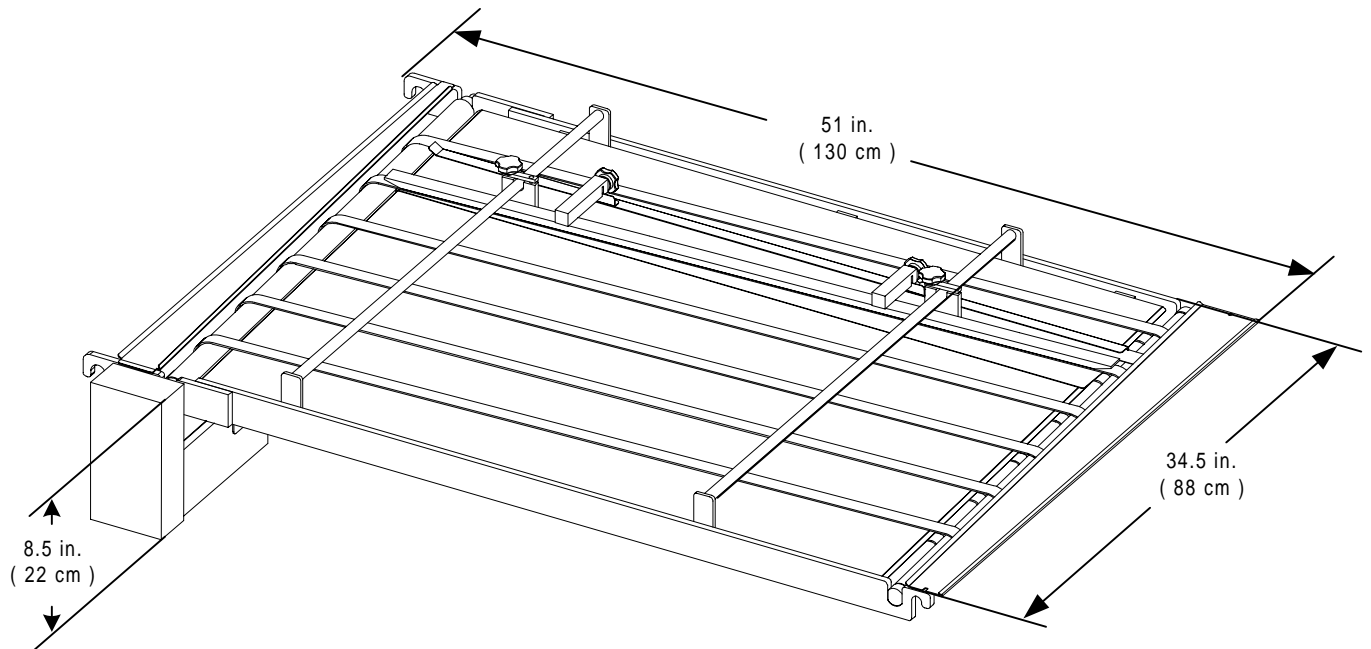

Figure 3.5.2 Conveyor



This page intentionally left blank.

Section 4 Installation

GBC Pro-Tech is committed to a program of ongoing product improvement. As a result, we are providing these instructions so that you can insure that your new Digital Feeder is properly and securely unpacked, moved, and installed.

Before the Digital Feeder can be installed, there are a few requirements that must be met. Ensure that each of the requirements listed in the following pre-installation checklist are met before beginning installation.



CAUTION

Failure to follow the pre-installation check list can result in damage to the cutter.

4.1 Pre-installation

- Are doorways and hallways wide enough for the Digital Feeder to be moved to the installation site?
- Is there ample room for the Digital Feeder?
- A work area must be established that allows for unrestricted movement around the Digital Feeder and provides space for efficient material flow. **Figure 4.1.1** illustrates a typical machine area layout.

- Electrical requirements: The Digital Feeder operates on 110 VAC, 15 amp service. The plug is standard two prong with a ground.
- Pneumatic requirements: 10 p.s.i. (10 kg / cm²).



WARNING

The Digital Feeder is a large and heavy piece of equipment. It is necessary to employ **LICENSED RIGGERS ONLY** to move the machine. The machine is not designed to be tipped up or sideways in any way. Such action disturbs the exact alignment of the moving parts of the machine and requires extensive realignment. You can be crushed or seriously injured.



INFORMATION

If you have a GBC Digital Cutter inline with the feeder and laminator, refer to **Figure 4.1.2 Optional cutter layout**

Figure 4.1.1 Suggested Floor Layout

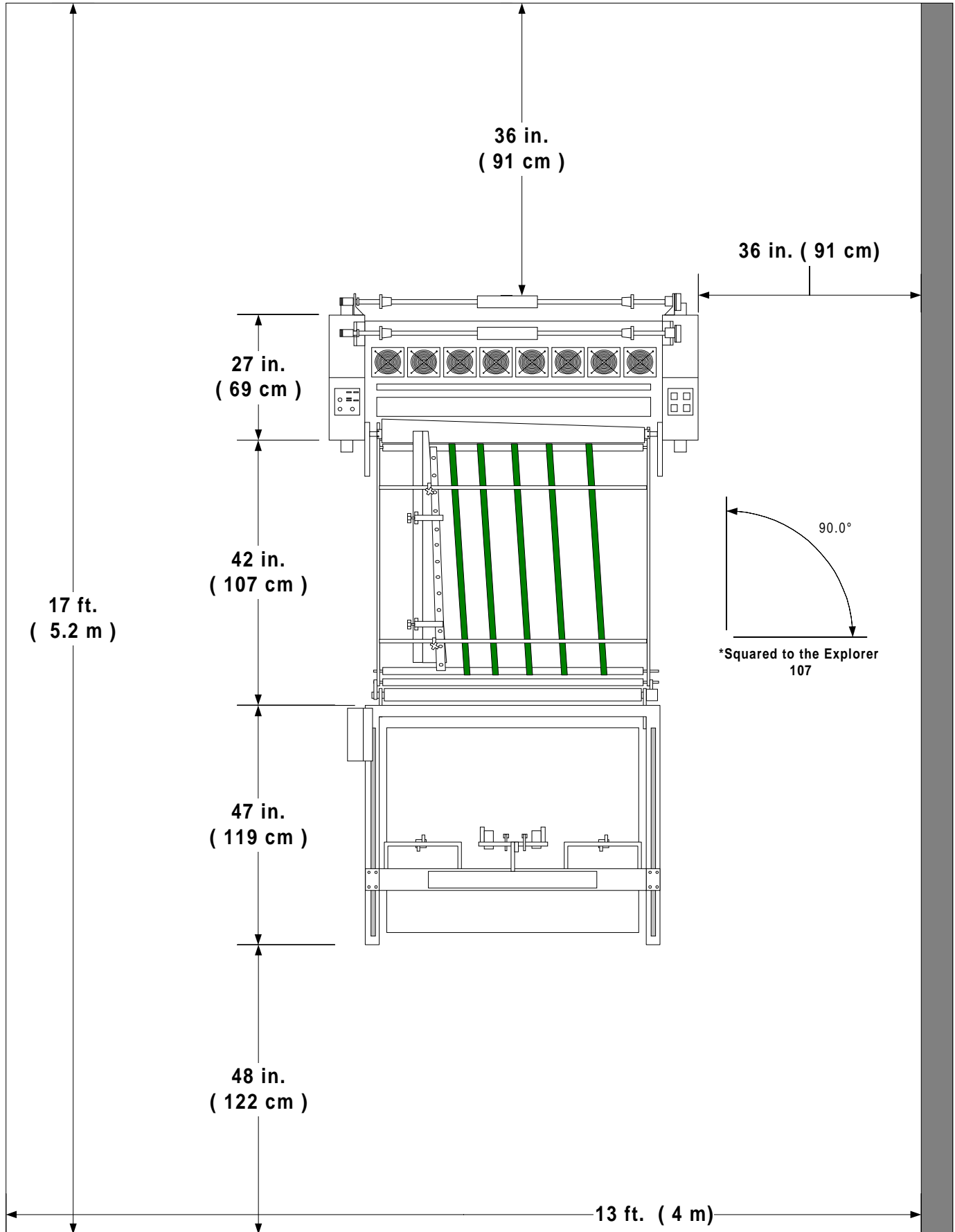
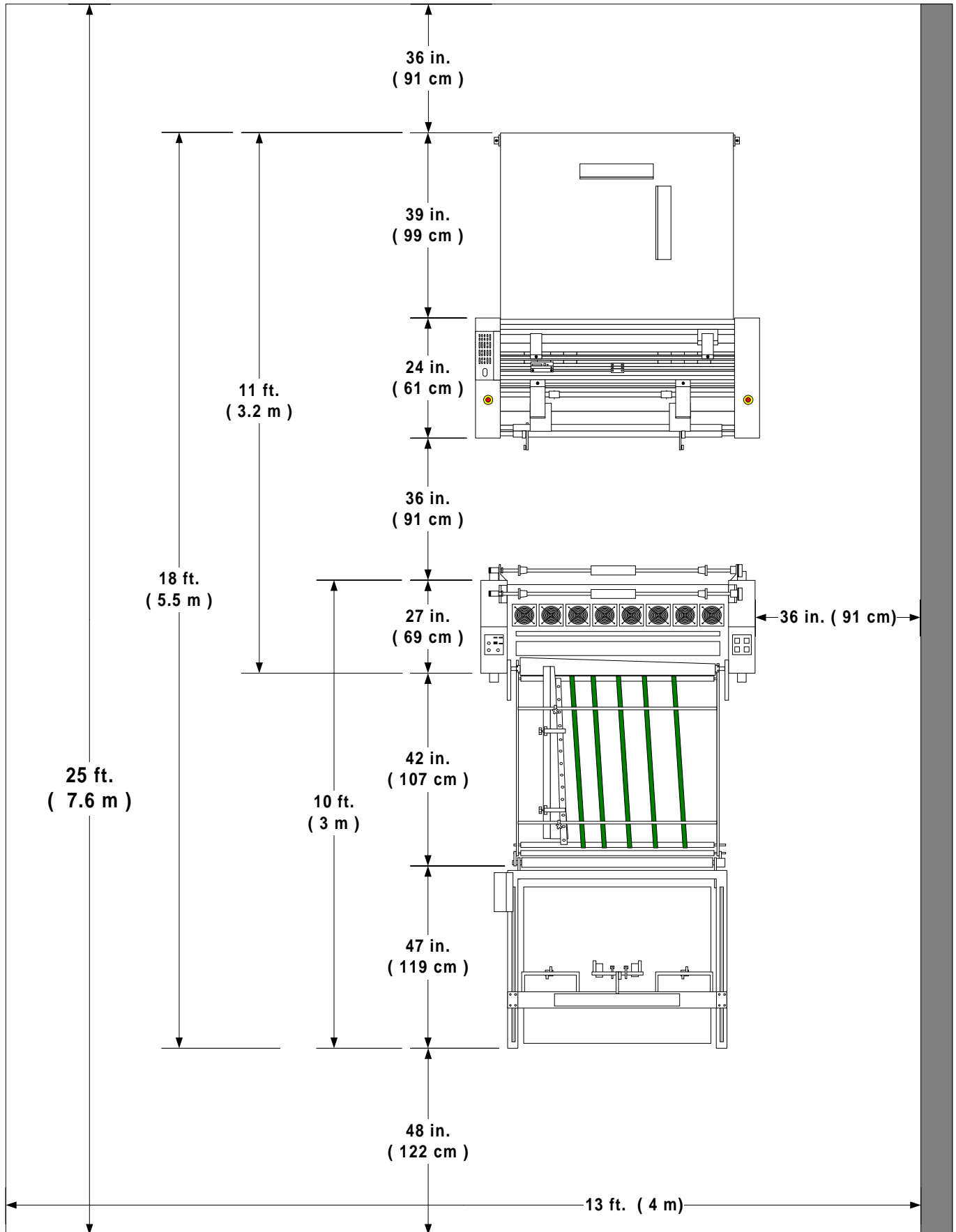

Figure 4.1.2 Optional cutter Layout



4.2 Know your Machine

Before performing any procedure within this manual, it is recommended that you take time to know the parts of your new machine.

Figure 4.2.1 Sides of the feeder

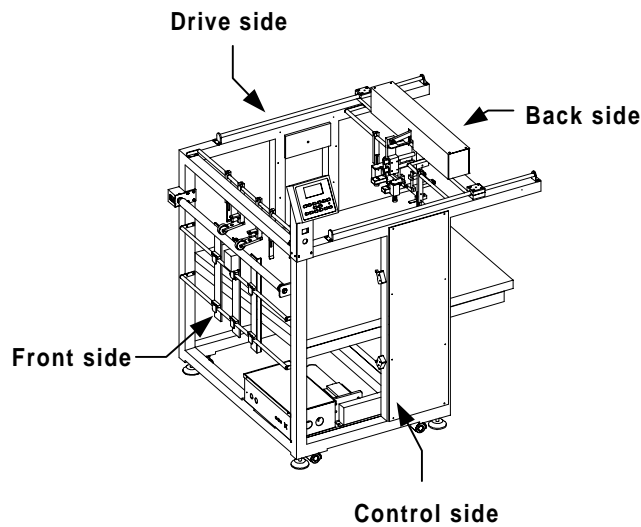
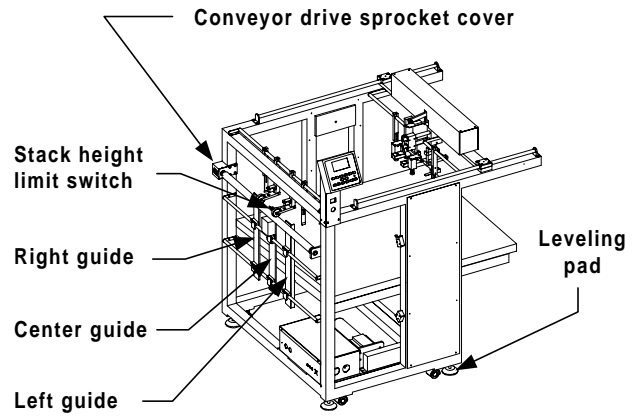

Figure 4.2.2 Parts of the feeder

Figure 4.2.3 Feeding head unit

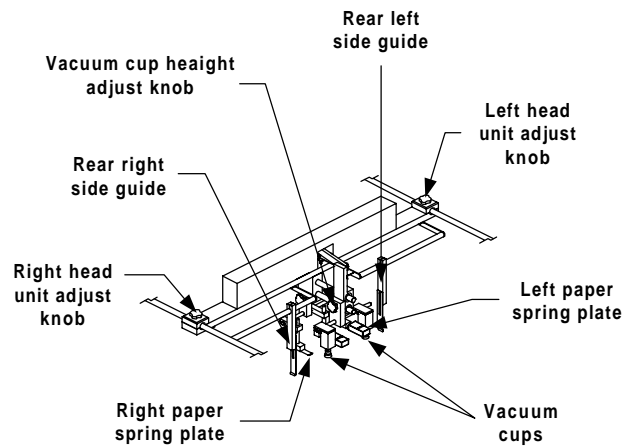

Figure 4.2.4 Sides of the conveyor

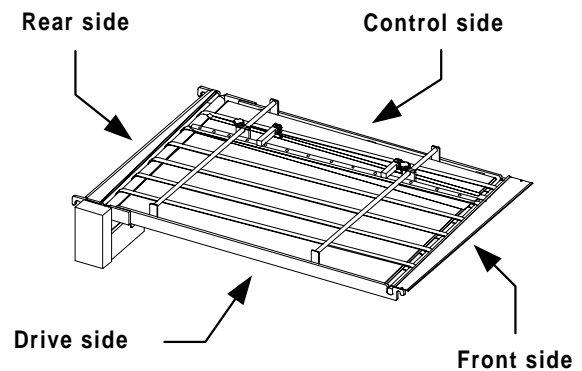
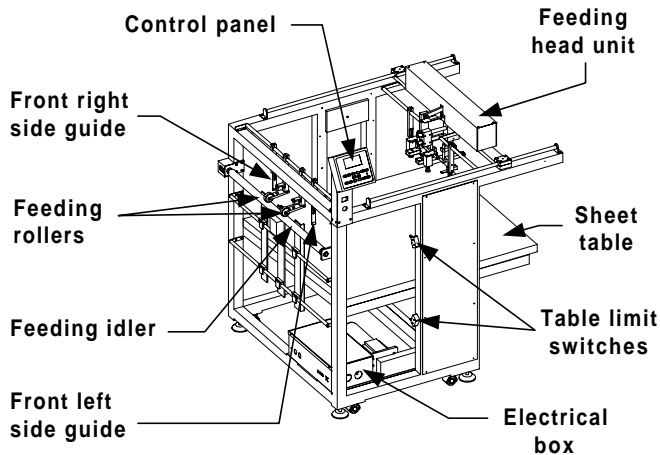
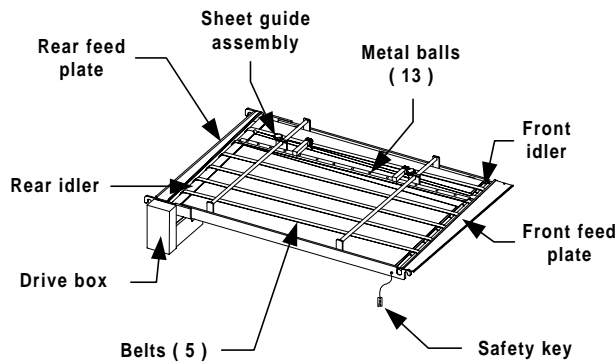

Figure 4.2.5 Parts of the conveyor



4.3 Unpacking



INFORMATION

ALL SHIPMENTS ARE EX-WORKS. At our dock, title passes to the buyer. Please review your insurance coverage prior to shipment, as you are responsible for all subsequent freight charges and risks.

Figure 4.2.6 Sheet guide assembly

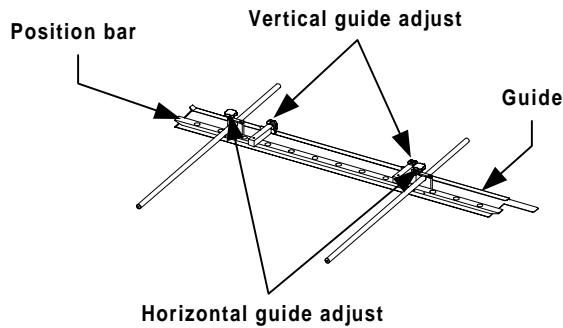

INFORMATION

Before signing the Bill of Lading, you should inspect the crate and / or pallet for signs of damage or missing items; if applicable, make note of this on the Bill of Lading.

The accessory bag attached to the conveyor when shipped contains;

- (13) Metal balls
- (1) Pneumatic tubing
- (1) Encoder cable



INFORMATION

Depending on the destination and customer preference, the Digital Feeder may be shipped by various methods. The machine may arrive shrink wrapped or in a plywood crate on a skid. Please follow the unpacking procedure that pertains to your method of shipment.

**WARNING**

The unpacking process requires at least two people. You can be severely injured, crushed or cause damage to the equipment.

With regards to your shipping methods, use one of the following procedures described to safely and properly unwrap / uncrate your cutter.

- b) Carefully unwrap the shrink wrap from around the Digital Feeder.

**CAUTION**

Do not use an open blade to cut the shrink wrap from the machine. You can cause damage to the equipment!

- c) Move all packing materials to a safe distance from the equipment and dispose of properly.

4.4 Shrink wrapped

Tools required

- # 2 Phillips head screwdriver
- Large adjustable wrench
- Crow bar
- A second person

- a) Inspect the machine for any obvious shipping damages upon receipt.

**INFORMATION**

Claims for shipping damages must be handled between your insurance company and the shipping company.

**INFORMATION**

The shrink wrap is not recyclable, therefore it must be discarded.

- d) Use two people to carefully roll the feeder and conveyer to the desired location.

**WARNING**

Do not attempt to move the Digital Feeder across anything other than a flat level surface. You can be crushed or seriously injured.

4.5 Crated

Tools required

- # 2 Phillips head screwdriver
- Large adjustable wrench
- Crow bar
- A second person

a) Inspect the machine for any obvious shipping damages upon receipt.



INFORMATION

Claims for shipping damages must be handled between your insurance company and the shipping company.

b) Remove the top of the crate and then the sides in the order shown in **Figure 4.5.1**



CAUTION

Do not allow the top to fall into the crate. It can damage the feeder.



INFORMATION

Do not put packing screws on the floor. They can cause problems when trying to roll the feeder into position or you can become injured if stepped on.



CAUTION

A second person must support the side labeled 5 in Figure 4.5.1. It can fall and damage the Feeder or cause harm to you and others.

Figure 4.5.1 Disassembling of the crate

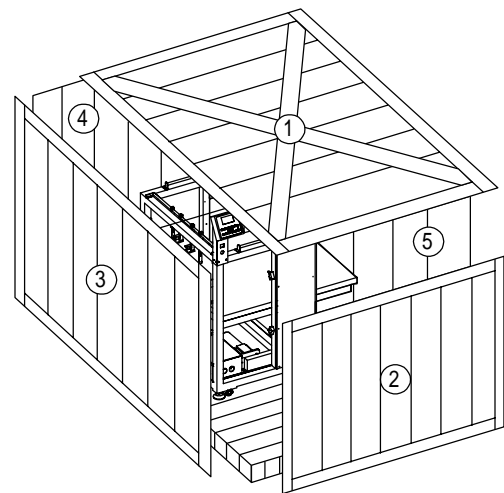

INFORMATION

The crate components can be reused for shipping the machine again or may be disassembled and recycled.

c) Gently unwrap the shrink wrap from around the feeder and conveyor.

e) Inspect the machine for any obvious shipping damages.



CAUTION

Do not use an open blade to cut the shrink wrap from the machine. You can cause damage to the equipment!

f) Move all packing materials to a safe distance from the equipment and dispose of properly.



INFORMATION

The shrink wrap is not recyclable, therefore it must be discarded.

d) Remove the shipping bolts from the feeder and have the feeder lifted from the skid and placed on the floor by licensed riggers.



WARNING

The Digital Feeder is a large and heavy piece of equipment. It is necessary to employ **LICENSED RIGGERS ONLY** to move the machine. The machine is not designed to be tipped up or sideways in any way. Such action disturbs the exact alignment of the moving parts of the machine and requires extensive realignment. You can be crushed or seriously injured.

g) Use two people to carefully roll the feeder and conveyor to the desired location.



WARNING

Do not attempt to move the Digital Feeder across anything other than a flat level surface . You can be crushed or seriously injured.



INFORMATION

GBC Pro-Tech's warranty does not cover malfunction of the equipment due to mishandling and / or tipping. GBC Pro-Tech bears no responsibility for personal injury or damage due to moving the feeder improperly.

h) Continue with **4.6 Set up**.

4.6 Set up

Follow the set up procedure to properly separate the conveyor from the feeder, preparing the laminator and installing the conveyor.

Tools required

- Tape measure
- A second person
- A third person
- Side cutters
- #2 Phillips screw driver

Separating the conveyor

- a) Set the front side of the feeder approximately 49 inches (124 cm) from the front of the Explorer 107 Laminator.

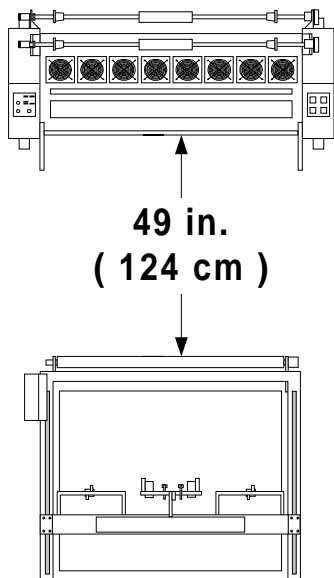

- b) Remove the accessory bag secured to the top of the conveyor and set it aside for now.

Accessory bag contents:

- Thirteen (13) Metal balls
- One (1) Encoder cable
- One (1) pneumatic hose

- c) Cut the two banding straps securing the conveyor to the sheet table of the feeder. Refer to **Figure 4.6.1 Banding straps**



CAUTION

Do not use a knife or other sharp objects to remove the strapping / ties from around the machine. You can cause damage to the equipment.

Figure 4.6.1 Banding straps

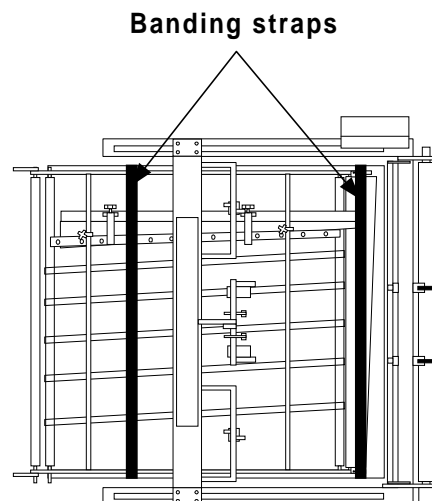

- d) Use a second person to assist with lifting the conveyor off of the sheet table. Set the conveyor near the laminator. Refer to **Figure 4.6.2 Sliding the conveyor out**.

- e) Cut the zip ties securing the power cord, the feeding rollers and the conveyor drive cable.



WARNING

Always use safe and proper lifting practices when lifting heavy objects. You can become seriously injured or crushed.

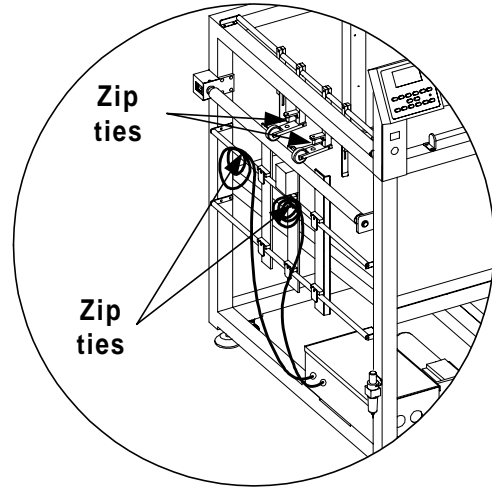
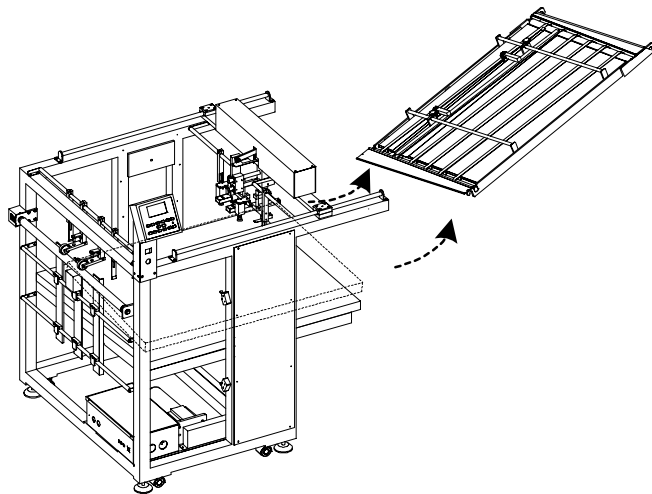

Figure 4.6.2 Sliding the conveyor out

- f) Set the power cord and conveyor drive cable neatly next to the electrical box.



Preparing the laminator

- a) Pull both safety latches on the front safety shield toward the center of the laminator.



CAUTION

Do not stand the conveyor on its side. Lay the conveyor flat on the floor. You can cause damage to the equipment!

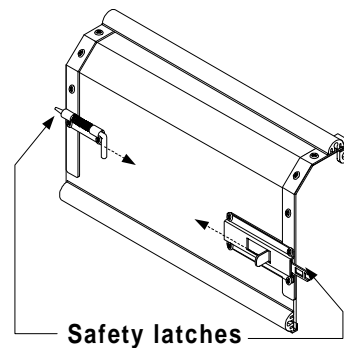



WARNING

Caution should always be exercised when using the laminator with the safety shields raised. You can be seriously **HURT** or **INJURED**!

b) Raise the safety shield to its full up right position.

c) Pull the two locator latches of the pressure plate toward the center of the laminator.

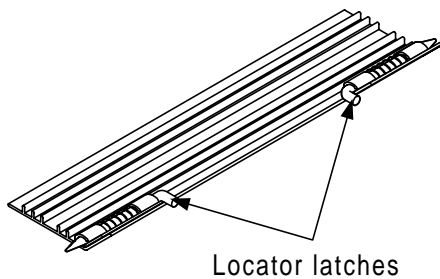

e) Pull the two safety latches on the feed table toward the center of the laminator.

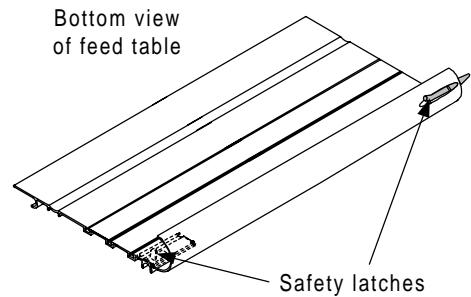

f) Lift the table from the front and pull out away from the laminator. Set the table in a safe place.

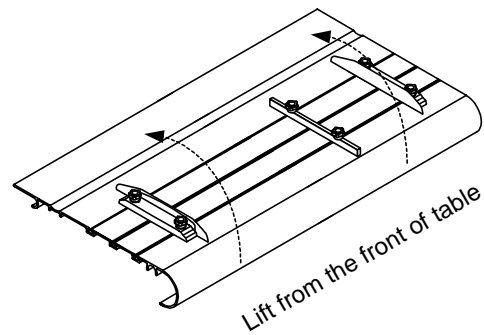

INFORMATION

The Explorer 107 pressure plate will not be used in conjunction with the Digital Feeder.



INFORMATION

The Explorer 107 feed table will not be used in conjunction with the Digital Feeder.

d) Remove the pressure plate and set in a safe place away from the laminator.

Installing the conveyor

a) Use the # 2 Phillips screw driver to remove the two screws securing the conveyor drive sprocket cover.

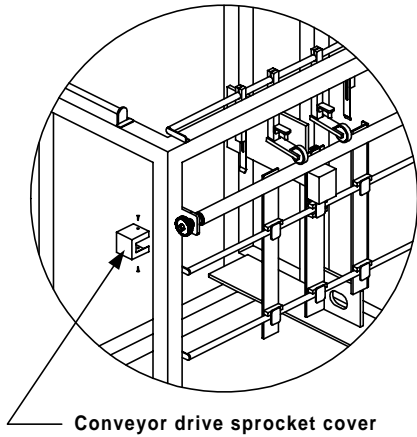

b) Use a second person to assist with lifting the conveyor and setting the rear of the conveyor to the front of the feeder..

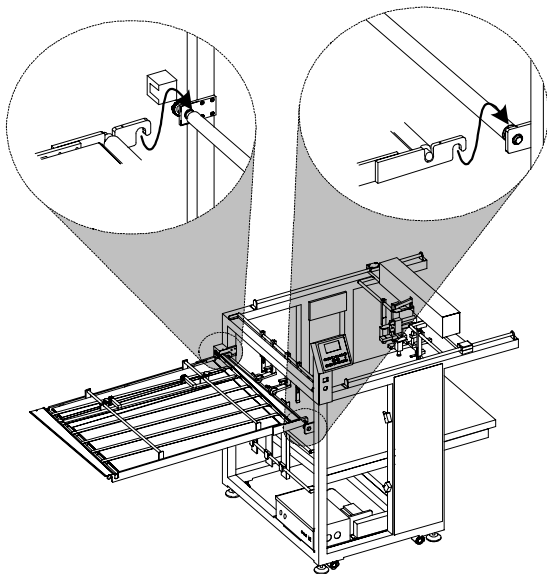

c) The third person will push the feeder forward while the two people supporting the conveyor align it to the two support bars on the laminator.

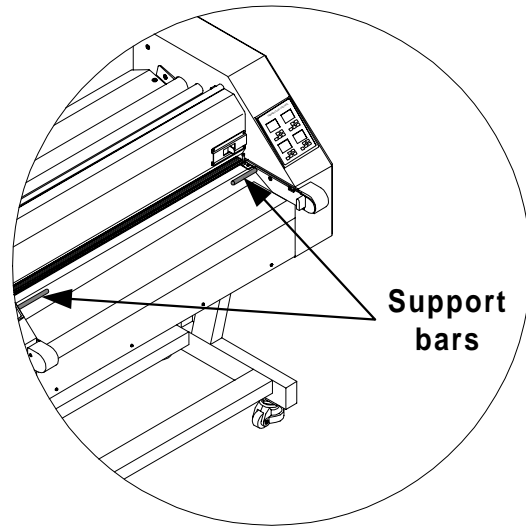

d) Replace the conveyor drive sprocket cover and secure with the two screws using the # 2 Phillips screw driver.

e) Insert the safety key attached to the conveyor into the interlock switch on laminator.

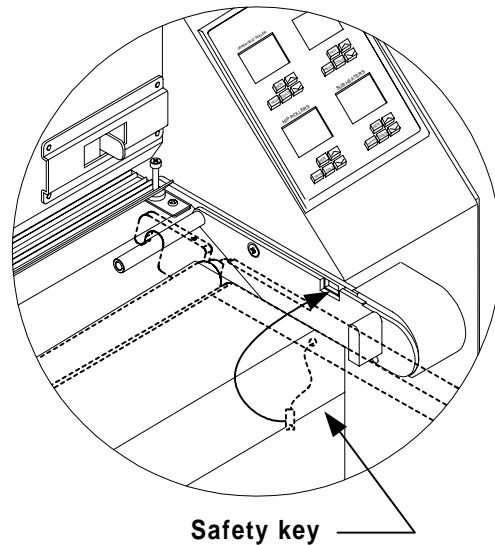

4.7 Leveling

Leveling of the feeder is very important in the way the machine performs. Leveling is crucial to the tram (tracking) of the materials through the machine.



INFORMATION

Improper leveling, will result in poor output quality.

- b) Position the level on top of the cross bar along the front side of the feeder. Refer to **Figure 4.7.1 Front side**

Figure 4.7.1 Front side

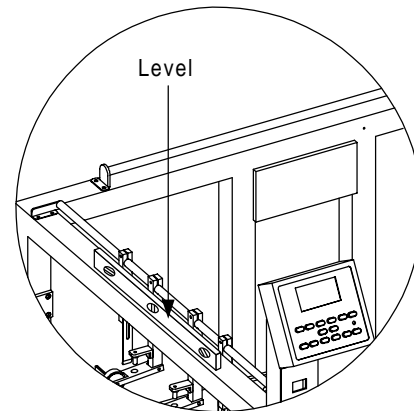

Tools required

- Torpedo level
- (2) 19 mm open end wrenches
- Second person

- c) With two 19 mm wrenches, adjust the foot bolts so that the front side is even from left to right. Refer to **Figure 4.7.2 Foot bolt**

Figure 4.7.2 Foot bolt

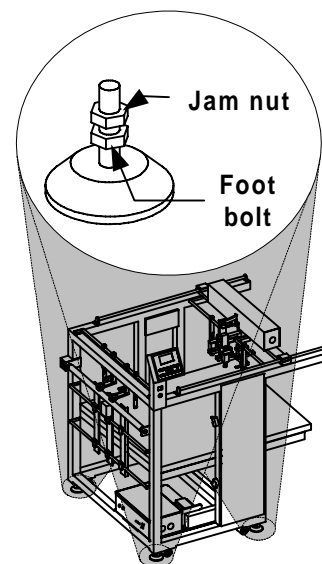

Control side to drive side

- a) Verify that the feeder has sufficient room around it to load paper, walk around and service if necessary.



INFORMATION

One person will read the level while the other person makes the necessary adjustments.

- d) Position the level on the rear cross bar. Refer to **Figure 4.7.3 Rear cross bar**.

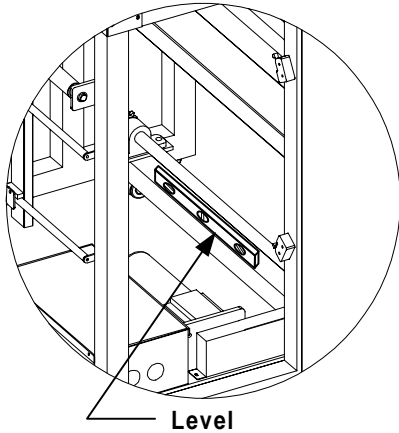

- b) With two 19 mm wrenches, adjust the foot bolts so that the control side is even from front to back. Refer to **Figure 4.7.2 Foot bolt**

- c) Position the level on the drive side. Refer to **Figure 4.7.5 Drive side**

Figure 4.7.5 Drive side

- e) With two 19 mm wrenches, adjust the foot bolts so that the front side is even from left to right. Refer to **Figure 4.7.2 Foot bolt**

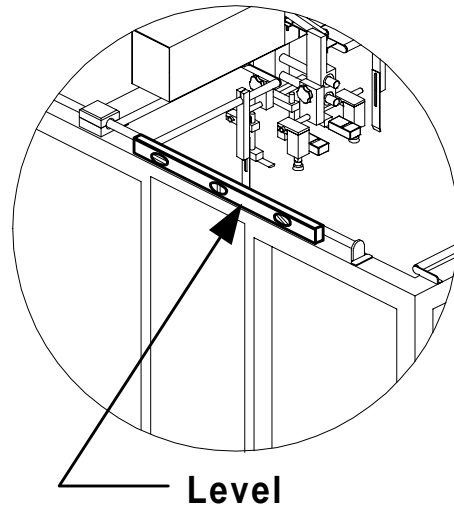

Front side to back side

- a) Position the level on the control side. Refer to **Figure 4.7.4 Control side**

Figure 4.7.4 Control side

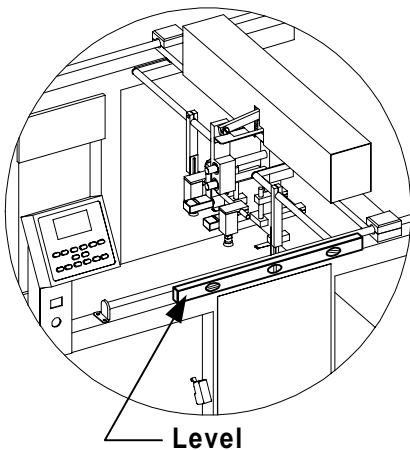

- d) With two 19 mm wrenches, adjust the foot bolts so that the drive side is even from front to back. Refer to **Figure 4.7.2 Foot bolt**

- e) Verify all four leveling points to ensure that all four sides are leveled.

4.8 Connections

Connections will consist of power, encoder, air, conveyor drive cable, placement of the metal balls and connecting air to the optional GBC Digital Cutter.

Inspect all cables and hoses for damage before connecting them. Any damage cable or hose should be replaced immediately.

Power

The feeders plug requires a grounded three prong receptacle. This unit operates on standard 110 VAC.

- a) Connect the power cord from the electrical box of the feeder to its proper receptacle.

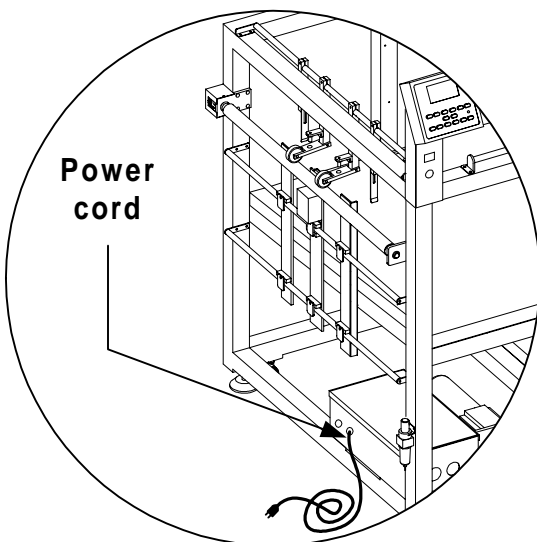

Conveyor drive cable

- a) Connect the conveyor drive cable from the feeders electrical box to the conveyors drive box. Refer to **Figure 4.8.1** and **Figure 4.8.2**

Figure 4.8.1 Conveyor drive cable

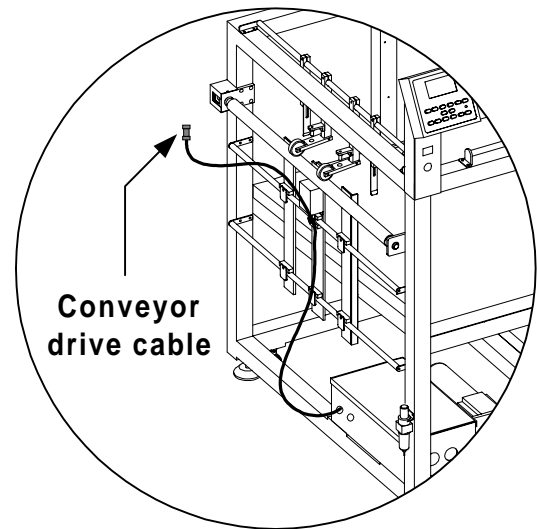
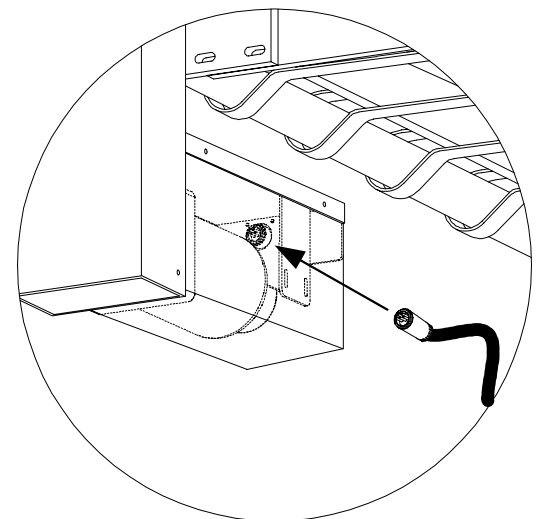

Figure 4.8.2 Conveyor drive box



Air

You, the customer, have two options to connecting air to the feeder. (1) connect air directly to the filter or (2) connect air to the filter via a quick disconnect coupler*.

* If using 1/4 inch O.D. pneumatic tubing, you may use a Quick Change coupler (GBC P/N 330260) and a male air fitting connector (GBC P/N 330600).

- a) Connect air to the air filter mounted on the feeder near the electrical box.

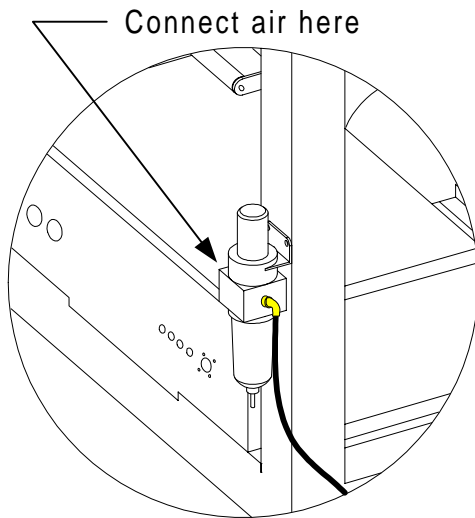

INFORMATION

The JUN-AIR compressor will not work for the feeder due to lack of air volume.

Encoder

The encoder cable allows the laminator and the feeder to communicate as one unit. The laminator will determine the speed of the feeder.

- a) Remove the encoder cable from the accessory bag.



INFORMATION

Both ends of the encoder cable are identical.

- b) Connect one end of the encoder cable to the electrical box encoder receptacle.

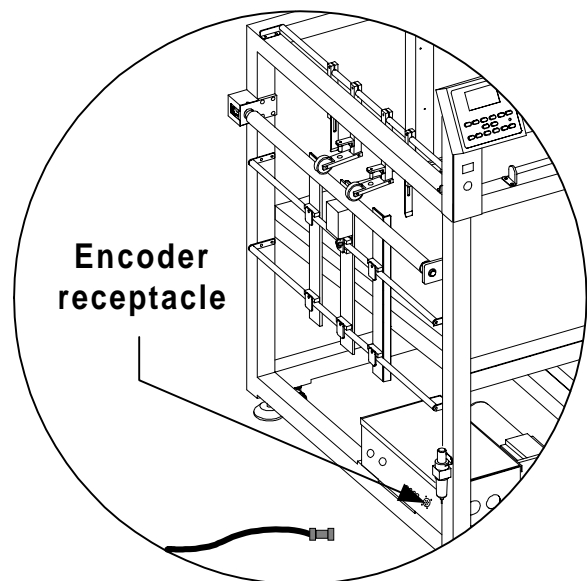

- c) Connect the opposite end to the encoder receptacle on the Explorer 107 Laminator.

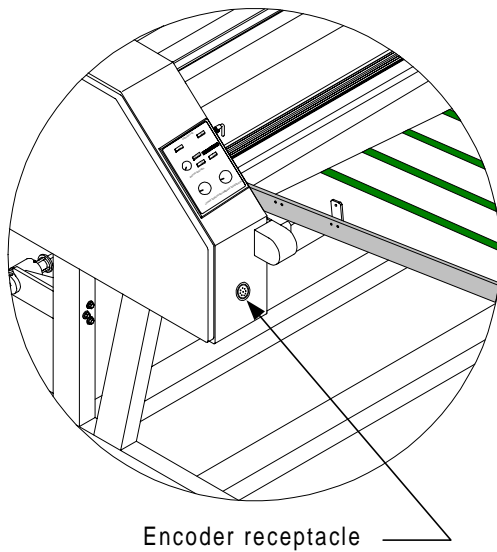

Optional cutter

The GBC Explorer System™ is composed of the GBC Digital Feeder, GBC Explorer 107 Laminator and the GBC Digital Cutter. The feeding head unit of the feeder is equipped with a spare nozzle to provide air to the cutter.

- a) Remove the pneumatic hose from the accessory bag.

- b) Push one end into the air fitting labeled Spare Nozzle on the back of the feeding head unit.

Metal ball placement

- a) Remove the 13 metal balls from the accessory bag.
- b) Place one metal ball into each of the holes in the position bar on the sheet guide assembly.

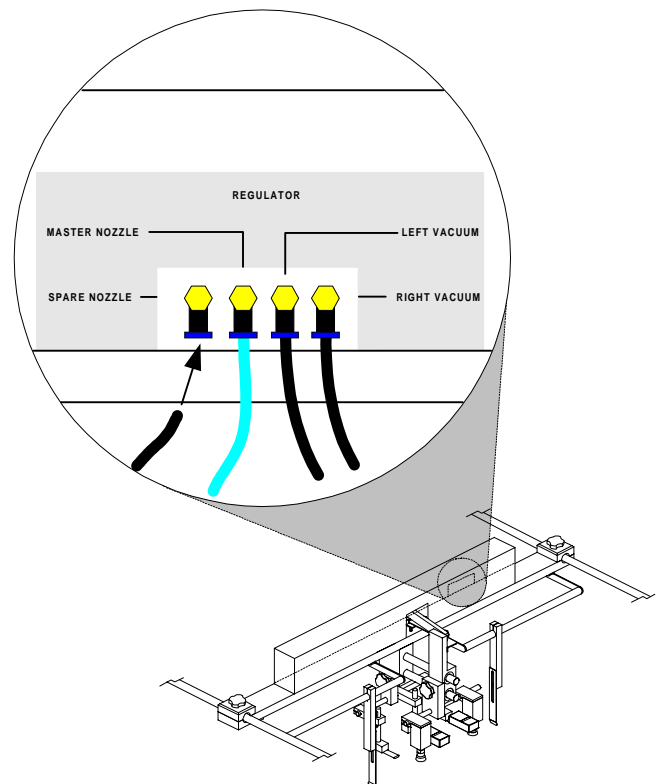
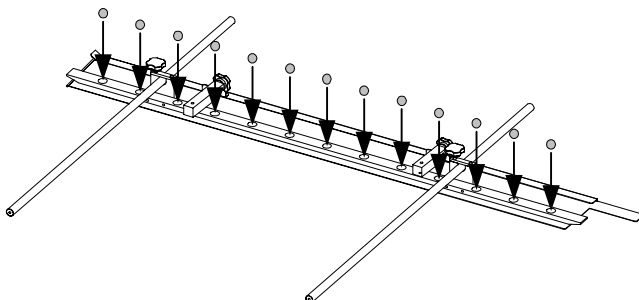

- c) Push the opposite end of the pneumatic tube into the air fitting of the cutter located below the main power ON/OFF.

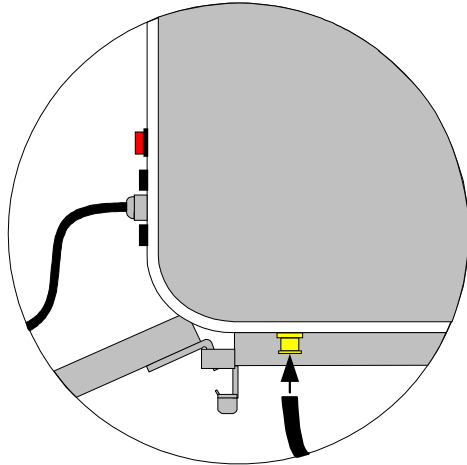

When finished with all of the necessary connections, zip ties should be used to neatly route the cables, pneumatic hoses and cords. This will prevent entanglement with these items while working around the system.



INFORMATION

Do not pinch the pneumatic tubing when using zip ties to route. Pinching will constrict the air flow.

4.9 Safety check

The safety check will ensure that all safety devices and interlock switches are functioning properly. Refer to **Section 5 Operations** for detailed explanation of the control panel.



WARNING

Do not wear ties, loose fit clothing or dangling jewelry while operating or servicing the feeder. These items can get caught in the machine and choke you or you can be crushed.



WARNING

If a safety feature is not functioning properly, contact your local service representative immediately

Safety on the feeder consists of the sheet table upper limit switch, sheet table lower limit switch and an emergency stops (**E-STOP**). Do not have the laminator webbed.



INFORMATION

The Explorer 107 and the Digital Feeder must both have power turned to ON.

Sheet table



INFORMATION

Ensure no E-STOP is depressed.



WARNING

Keep hands and feet away from the sheet table when raising or lowering.
You may be crushed!

b) Press **TABLE**  under TAB on the feeder control panel.

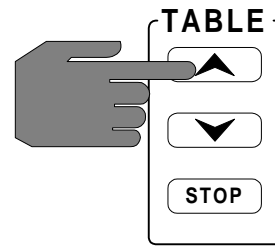

- Sheet table stops once the table upper limit switch is engaged. Refer to **Figure 4.9.1 Limits switches**.

- An audible beeping will sound until the table limit switch is deactivated.

a) Press **POWER** to “ — ” on the feeder.

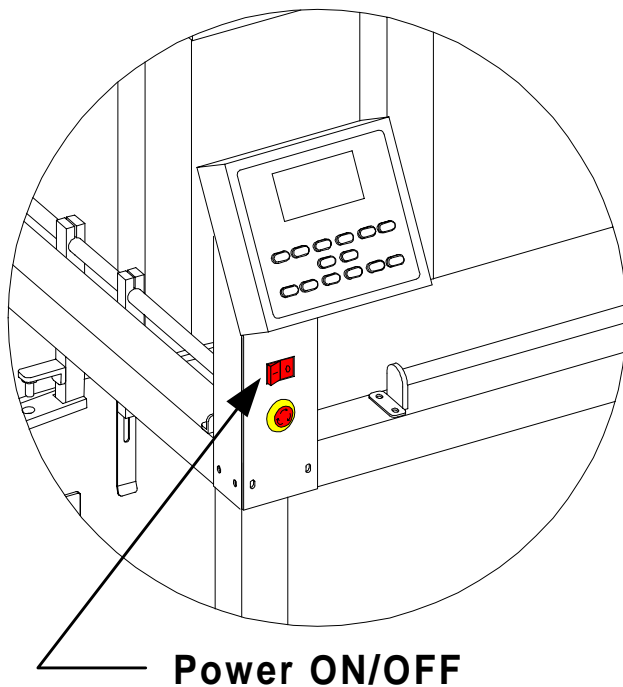
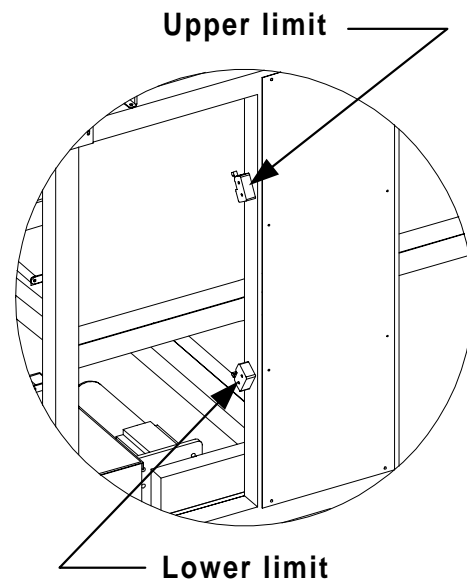

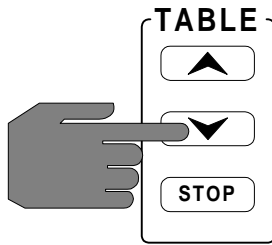

Figure 4.9.1 Limit switches



c) Press **TABLE**  on the feeder control panel.



- Sheet table stops once the table lower limit switch is engaged. Refer to **Figure 4.9.1 Limits switches**.

- The audible beeping will stop when the table upper limit switch is reset.

e) Position a 3 inch (7.6 cm) stack of 8.5 x 11 inch paper (21.6 x 27.9 cm) on the sheet table flush and center against the center guide.

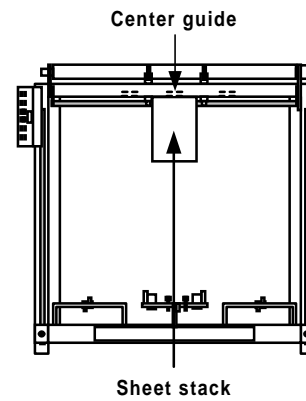

f) Press **TABLE**  on the feeder control panel.

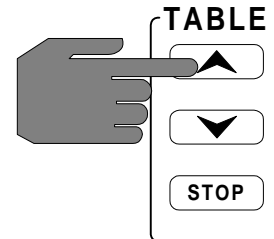

d) Loosen the left and right head unit adjust knobs and slide the feeding head unit to its far most back position.

- Sheet table stops once the stack height limit switch is engaged.

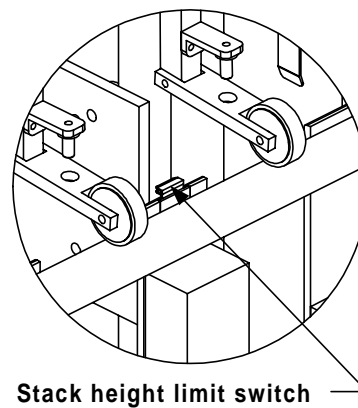
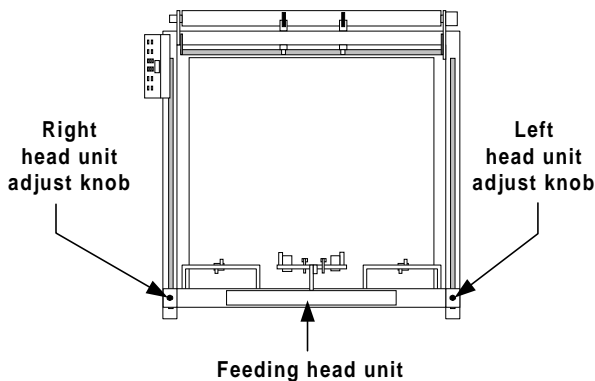

Emergency stops

Leave the sheet stack, the feeding head unit and the sheet table in the current position and continue with checking the emergency stop checks.

b) Lower the pull roller on the Explorer 107.



INFORMATION

Ensure no E-STOP is depressed.



INFORMATION

The encoder is attached to the upper pull roller on the Explorer 107.



INFORMATION

Explorer 107: Ensure no E-STOP is depressed and the front safety shield is in the fully closed and locked position.

c) Rotate **SPEED** to “5” on the Explorer 107 control panel.

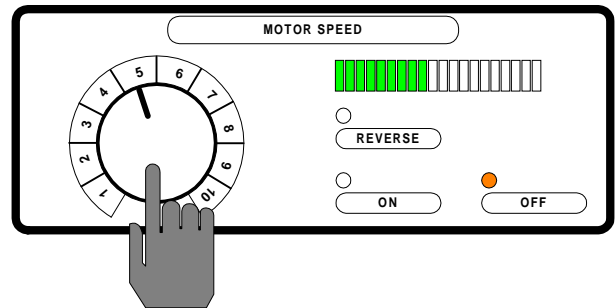

a) Press **POWER** to “I” on the Explorer 107.

d) Press **RUN** under **AUTO**. The rollers begin turning.

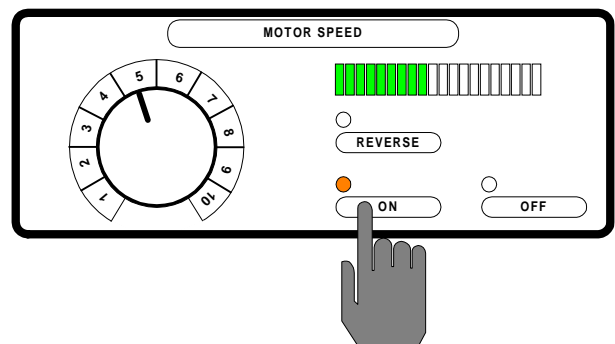
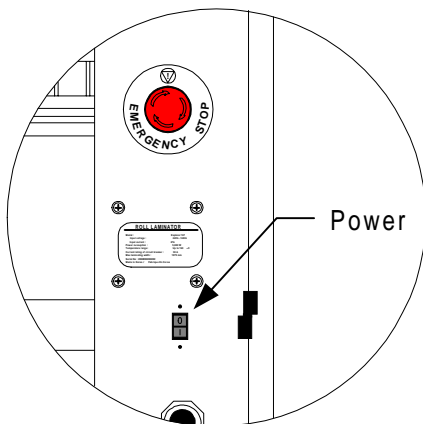



INFORMATION

The encoder on the Explorer 107 synchronizes the speed of the feeder.

d) Rotate the **E-STOP** clockwise to reset.

Rotate

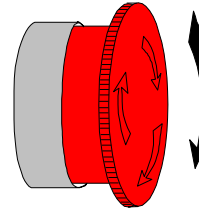

e) Press under **VACUUM** on the feeder.

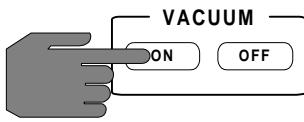

- Power to the feeder control panel is restored.

f) Press under **RUN** on the feeder.

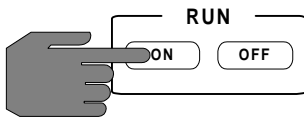

INFORMATION

The Explorer 107 E-STOPS will stop the feeder. Once the upper pull roller is engaged and turning, the feeder will resume running.

g) Push in the **E-STOP** located below the feeders ON/OFF.

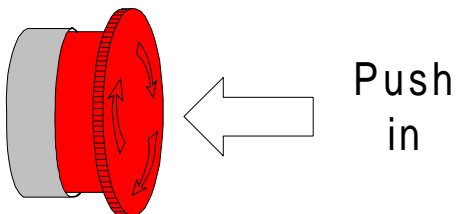

INFORMATION

The feeder will only operate if the Explorer 107 is running and the sheet stack limit switch is engaged.

- Power to the feeder control panel is removed.

4.10 Control panel check

The control panel should be checked to ensure all controls function properly. Confirm the control panel display reflects the input accordingly. The specific function of each command is explained in **Section 5 Operations**.

Although **RUN** and **VACUUM** commands have been pressed in previous steps, press them again in this procedure to confirm the display changes.

b) Press **RUN OFF**. An audible beep sounds and the **ON** light extinguishes.

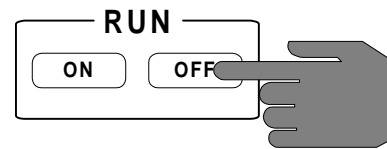

- Display shows

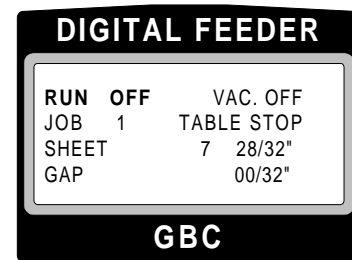

RUN

a) Press **RUN ON**. An audible beep sounds and the **ON** is illuminated.

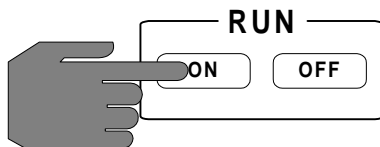

- Display shows

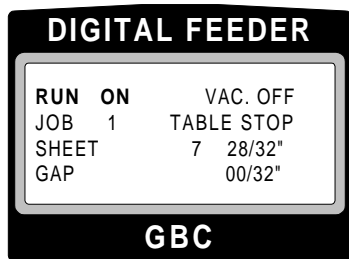

VACUUM

a) Press **VACUUM ON**. An audible beep sounds and the **ON** is illuminated.

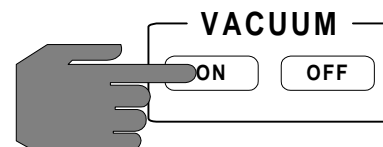

- Display shows

JOB

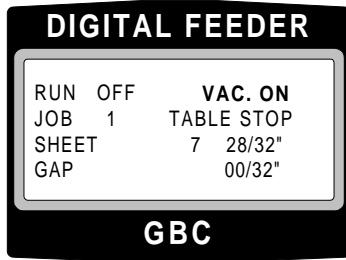

a) Press **JOB** (▲). An audible beep sounds per press and the numeric value for job increases. Maximum input value is 9.

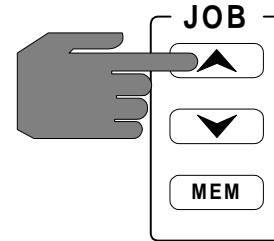

b) Press **VACUUM** (OFF). An audible beep sounds and the (ON) light extinguishes.

- Display shows

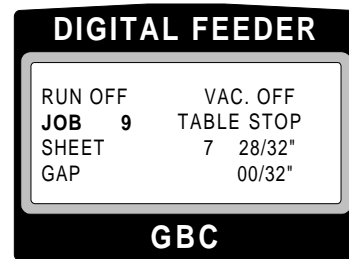
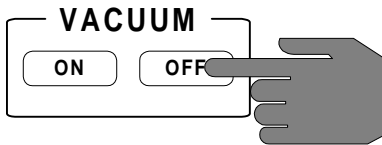

- Display shows

b) Press **JOB** (▼). An audible beep sounds per press and the numeric value for job decreases. Minimum input value is 1.

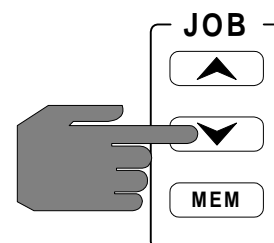
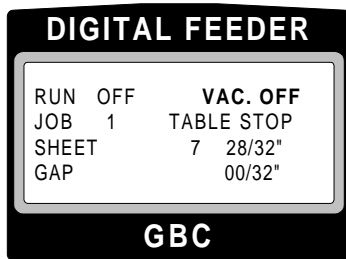

- Display shows

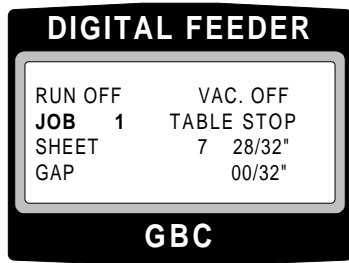

INFORMATION

Refer to Section 5.3 Job programming to store parameters.

TABLE

c) Press **JOB** (MEM). An audible beep sounds per press and the numeric value for job begins flashing.

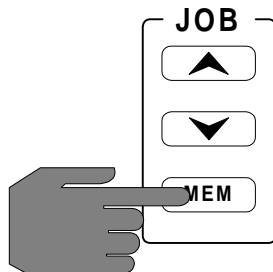

a) Press **Table** (▲). An audible beeps once per press. The sheet table begins to travel in an upward direction.

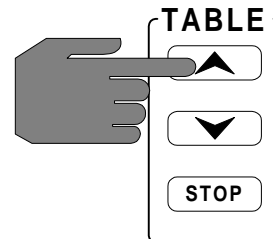

- Display shows

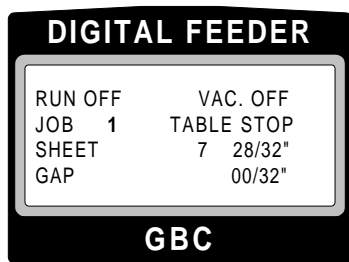

- Display shows

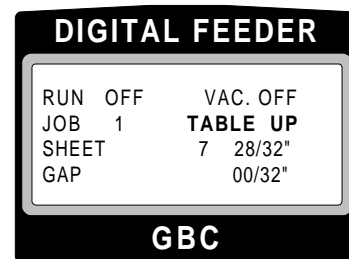

b) Press **Table** (STOP) . An audible beeps once per press. The sheet table stop traveling in an upward direction.

- Display shows

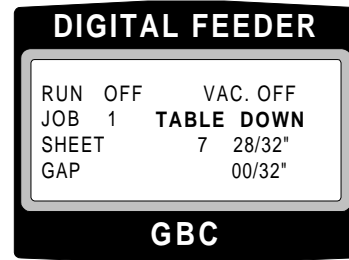
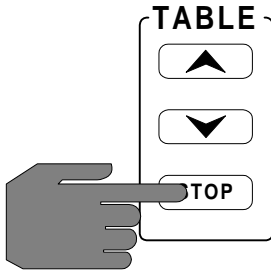

- Display shows

d) Press **Table** (STOP) . An audible beeps once per press. The sheet table stops traveling in a downward direction.

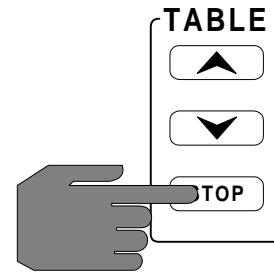
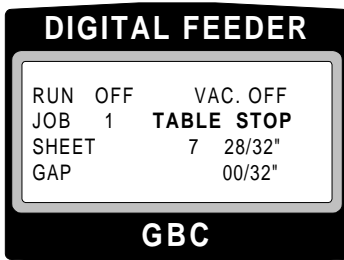

c) Press **Table** (▼) . An audible beeps once per press. The sheet table begins to travel in a downward direction.

- Display shows

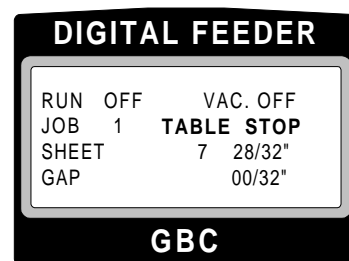
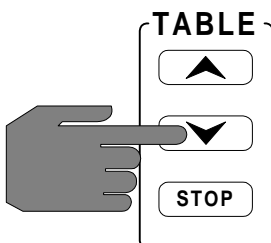

SHEET

- Display shows

- a) Press **SHEET** . An audible beeps once per press. Press and hold, five repetitious beeps sound and the input value automatically increases. Maximum input is 99 - 31/32".

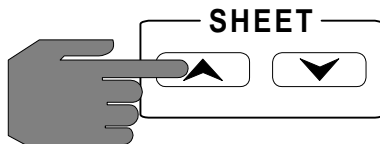
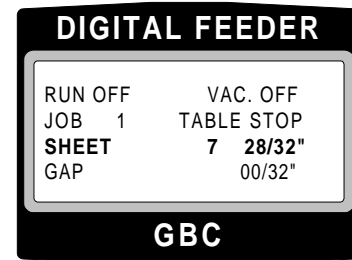

GAP

- Display shows

- f) Press **GAP** . An audible beeps once per press. Press and hold, five repetitious beeps sound and the input value automatically increases. Minimum input is 64/32".

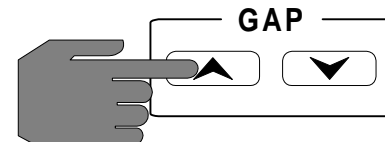
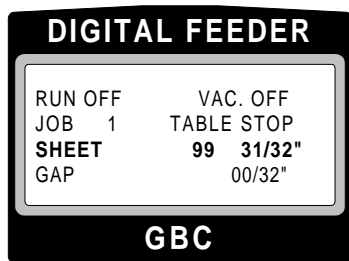

- b) Press **SHEET** . An audible beeps once per press. Press and hold, five repetitious beeps sound and the input value automatically decreases. Minimum input is 7 - 28/32".

- Display shows

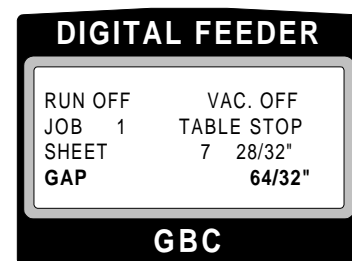
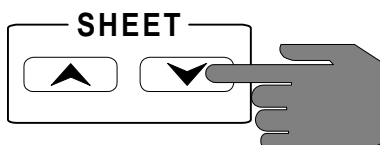

- g) Press **GAP** . An audible beeps once per press. Press and hold, five repetitious beeps sound and the input value automatically decreases. Minimum input is 00/32".

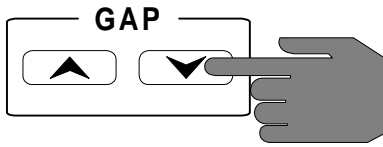

- Display shows

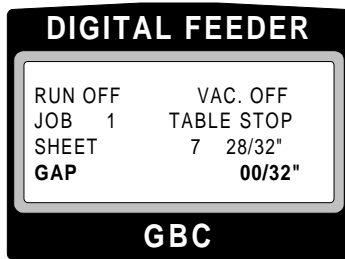

Section 5 Operations

Figure 5.1.1 Control panel location



WARNING

Do not wear ties, loose fit clothing or dangling jewelry while operating or servicing the feeder. These items can get caught in the machine and choke you or you can be crushed.

This section discusses Control panel, Emergency and Job programming.

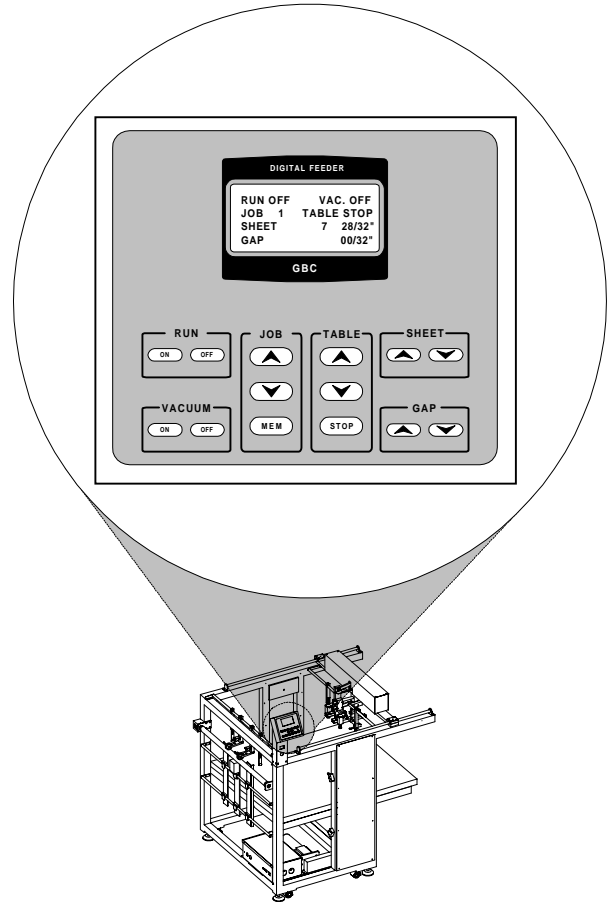

5.1 Control Panel

The control panel for the Digital Feeder is located on the control side of the machine. Refer to **Figure 5.1.1 Control panel**

The control panel is separated into six groupings. (**RUN**, **VACUUM**, **JOB**, **TABLE**, **SHEET** and **GAP**)

When **POWER** is pressed to “—”, the display panel will indicate the last **JOB** number, **SHEET** size and **GAP** entered before power was removed.



INFORMATION

Unit of measurement is set from the factory for SAE. If metric is preferable, contact your local service representative.



INFORMATION

Any command pressed will emit an audible beep per press.

(1) **RUN** **ON** : When pressed, illuminates and engages the conveyor drive motor.

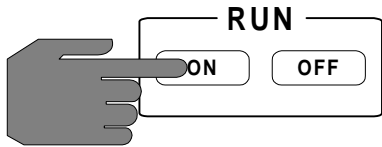

(3) **VACUUM** **ON** : When pressed, illuminates and engages the air and the feeding head unit drive motor.

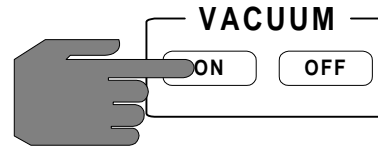

(2) **RUN** **OFF** : When pressed, stops the conveyor drive motor.

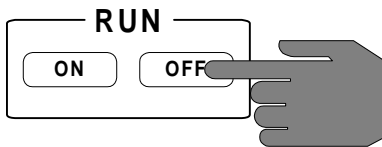

INFORMATION

Vacuum ON will only operate if RUN is ON.
Vacuum ON can be pressed to simultaneously engage with RUN ON

(4) **VACUUM** **OFF** : When pressed, stops the air and the feeding head unit drive motor



INFORMATION

If the vacuum is ON and OFF is pressed under RUN, vacuum will stop.

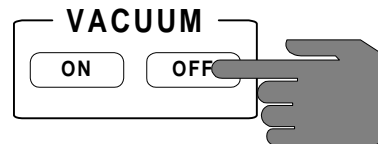

INFORMATION

If vacuum is ON and OFF is pressed under RUN, the feeding head unit will stop at its current position.



INFORMATION

When vacuum OFF is pressed, the feeding head unit will complete its cycle before stopping.

(5) **JOB** (▲): When pressed, increases the numeric value for job location. Maximum value is 9.

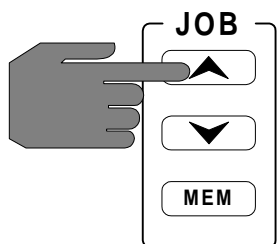

(6) **JOB** (▼): When pressed, decreases the numeric value for job location. Minimum value is 1.

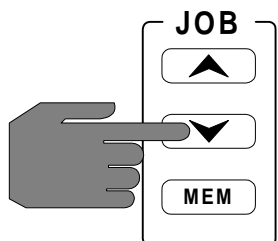

(7) **JOB** (MEM): When pressed, selects the job number displayed for storing parameters.

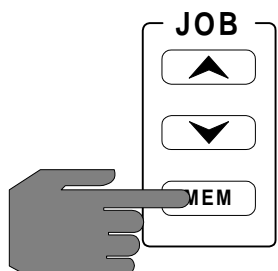

INFORMATION

Refer to Section 5.3 Job programming to store parameters.



WARNING

Keep hands and feet away from the sheet table when raising or lowering. You may be crushed!

(8) **Table** (▲): When pressed, engages the sheet table drive motor to travel in an upward direction.

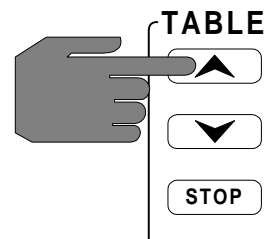

(9) **TABLE** (▼): When pressed, engages the sheet table drive motor to travel in a downward direction.

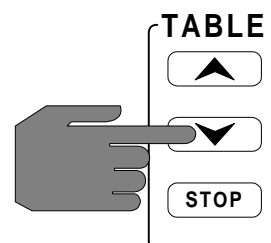

(10) **TABLE** (STOP) : When pressed, disengages the sheet table drive motor.

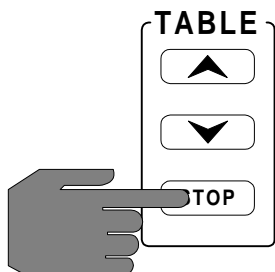

(13) **GAP** (▲) : When pressed, increases the gap size in increments of 1/32 of an inch. The maximum gap size is 64/32 in.

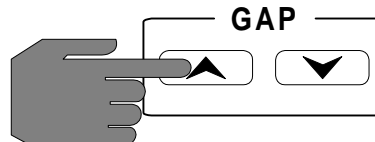

(11) **SHEET** (▲) : When pressed, increases the sheet size in increments of 1/32 of an inch. The maximum sheet size is 40 in. (102 cm)

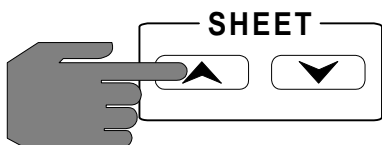

(14) **GAP** (▼) : When pressed, decreases the gap size in increments of 1/32 of an inch. The minimum gap size is 00/32 in.

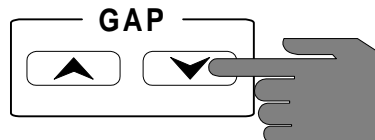

(12) **SHEET** (▼) : When pressed, decreases the sheet size in increments of 1/32 of an inch. The minimum sheet size is 11 in (28 cm)

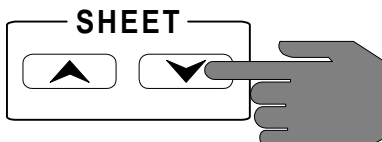

Refer to **Figure 5.1.1 Control panel** for an overall view of the control panel.

Figure 5.1.2 Control panel

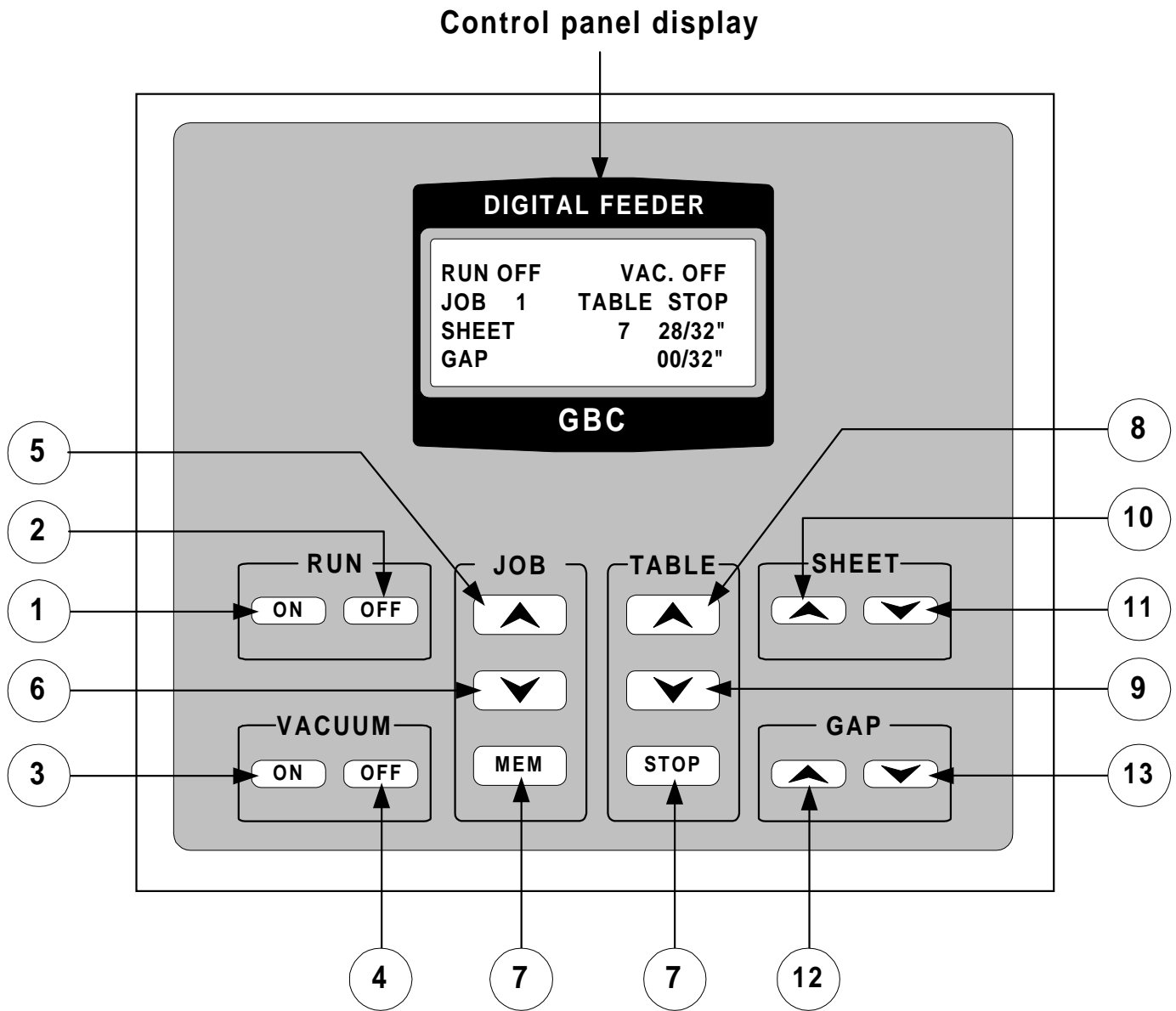

5.2 Emergency

Figure 5.2.2 Explorer 107 E-STOPS

The Digital Feeder has been designed with safety as a primary consideration; however, you must become thoroughly familiar with the controls, proper operation, proper service procedures, and safety features of the machine before using or servicing.



INFORMATION

The E-STOP on the Explorer 107 will stop the feeder. The E-STOP on the feeder will not stop the Explorer 107.

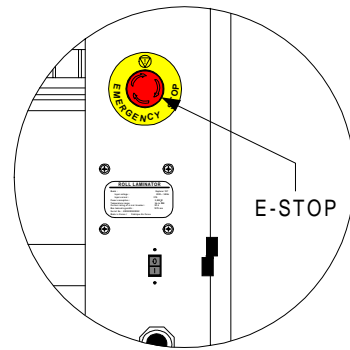
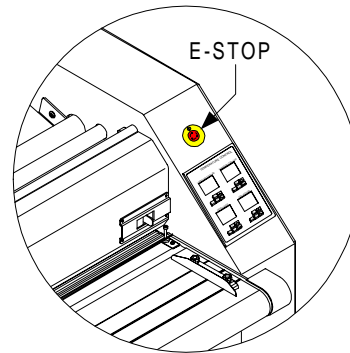

Know where the emergency stop on the feeder is (**Figure 5.2.1 Feeder E-STOP**) and the two E-STOPS on the Explorer 107 (**Figure 5.2.2 Explorer 107 E-STOPS**) are located before operating the equipment.

Reacting to an emergency

Figure 5.2.1 Feeder E-STOP

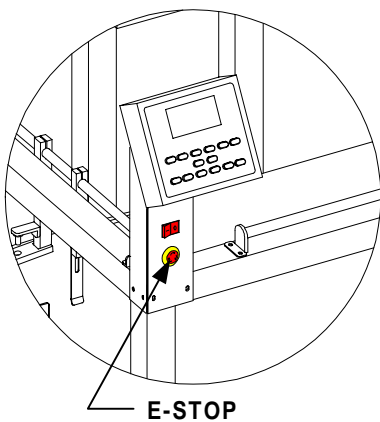

- a) In the event of an emergency, press an E-STOP.



INFORMATION

The E-STOP on the Explorer 107 will stop the feeder. The E-STOP on the feeder will not stop the Explorer 107.

b) Continue with the procedure according to the **E-STOP** that was depressed.

f) Press **VACUUM** .

- If the feeder **E-STOP** was used . . .

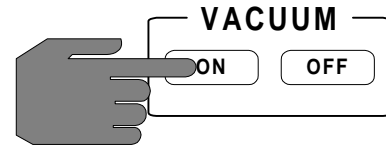

c) Press **Motor Speed OFF** to stop the Explorer 107.

g) Press **RUN** .

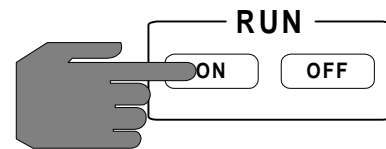
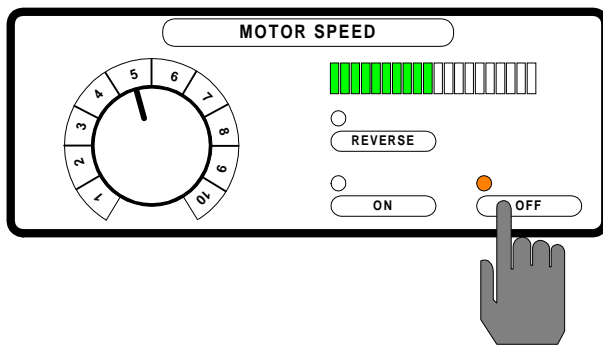

h) Press **Motor Speed ON** . The feeder starts along with the Explorer 107.

d) Resolve the emergency situation.

e) Reset the **E-STOP** by rotating 1/4 turn clockwise on the feeder.

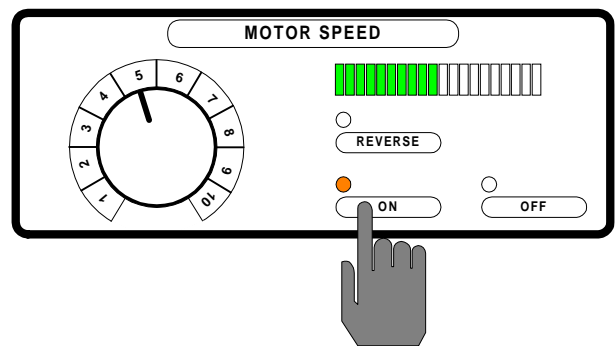

i) Resume running.

- If an E-STOP on the Explorer 107 was used . . .

5.3 Job programming

c) Resolve the emergency situation.

d) Reset the **E-STOP** by rotating 1/4 turn clockwise on the Explorer 107.



e) Press **Motor Speed ON** ON . The feeder starts along with the Explorer 107.

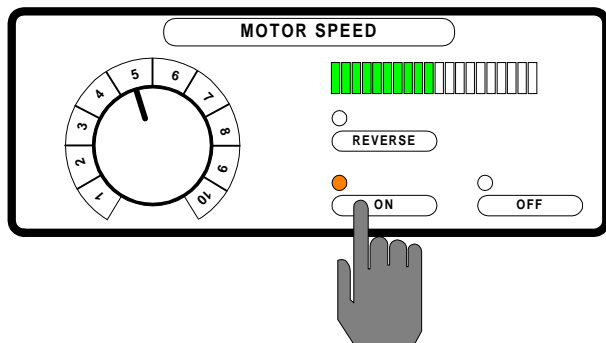

e) Resume running.

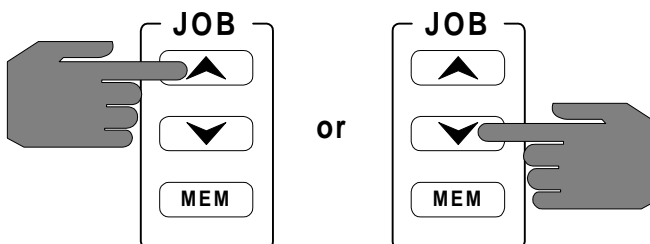

The job memory feature is very convenient if the same parameters are required to perform various feeding. This procedure will guide you step by step through this feature.

a) Press **JOB** or **JOB** to a desired numeric value.



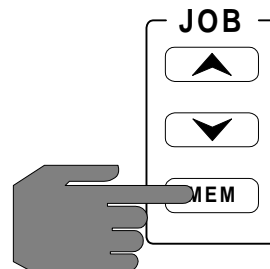

b) Press **JOB** . The numeric value begins to flash.



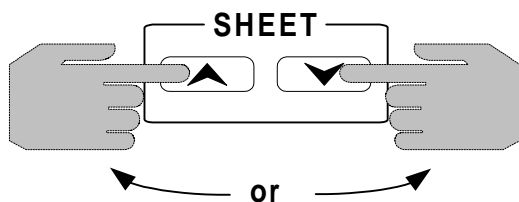

c) Press **SHEET**  or **SHEET**  to enter a sheet size.

Parameters have been stored in the displayed **JOB** number. Repeat steps to store parameters in other JOB numbers.

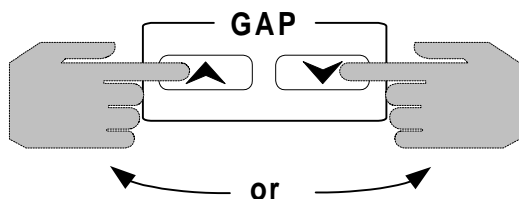

d) Press **GAP**  or **GAP**  to enter a desired gap setting.



e) Press **JOB** . The numeric value stops flashing.

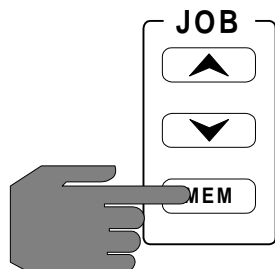

This page intentionally left blank.

Section 6 Getting started

6.1 Loading the sheet stack

Setting up the GBC Digital Feeder is quick and easy. Follow the four steps (loading the sheet stack, adjusting the guides, making adjustments and setting the controls) to properly get started.

The laminator at this point should be webbed and ready to run prior to setting up the feeder.



INFORMATION

A minimum sheet stack height of 3 in. (7.6 cm) is required for loading.



WARNING

Do not wear ties, loose fit clothing or dangling jewelry while operating or servicing the feeder. These items can get caught in the machine and choke you or you can be crushed.

a) Fold one sheet from the stack in half.

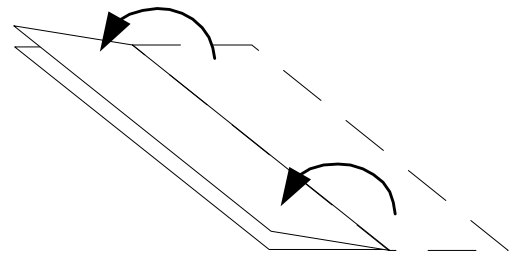

b) Unfold the sheet and place it back on the top of the sheet stack.



INFORMATION

The feeder will only operate if the Explorer 107 is running and the sheet stack limit switch is engaged.

Folded sheet

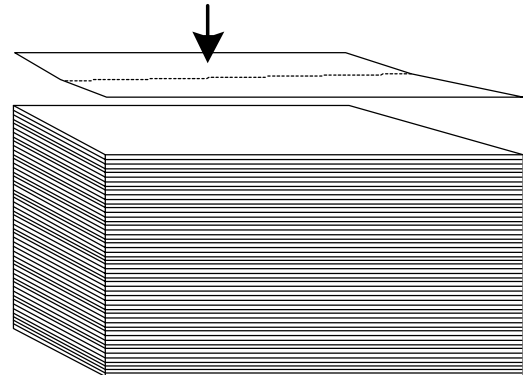

INFORMATION

All E-STOPS (Feeder and Explorer 107) must be in the unlatched position.

c) Set the sheet stack onto the sheet table.

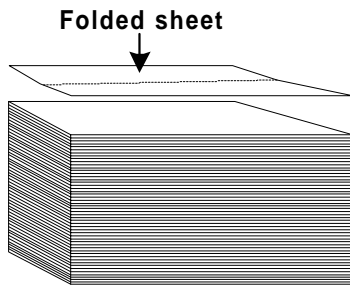

d) Slide the sheet stack up against the center guide.

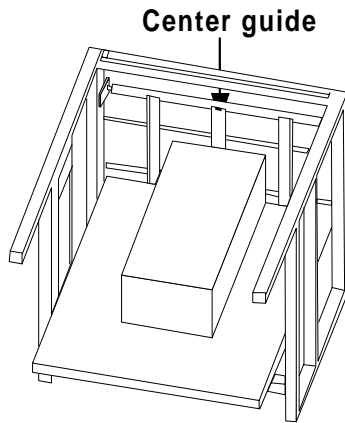

e) Align the crease from the fold of the top sheet so it is centered to the stack height limit switch.

f) Press **TABLE** . The table will raise and stop when the stack height switch is engaged.

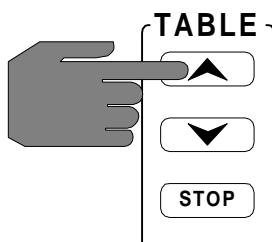

6.2 Adjusting the guides

a) Adjust the right guide and left guide flush against the sheet stack.

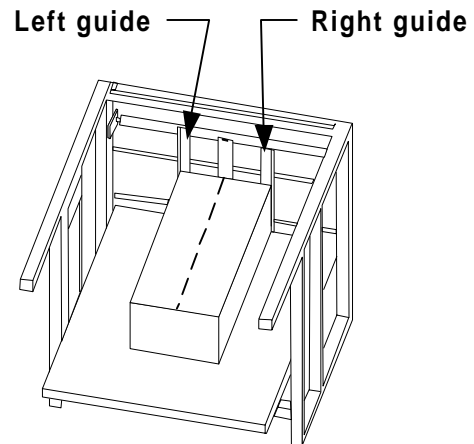

b) Adjust the front right and front left guide flush against the sheet stack.

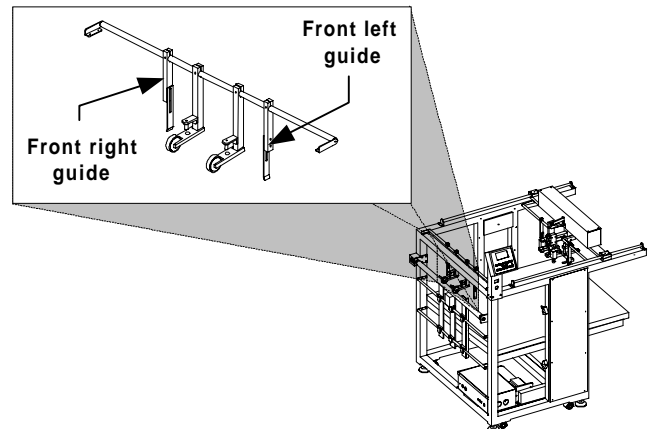

c) Press **RUN** on the feeder control panel.

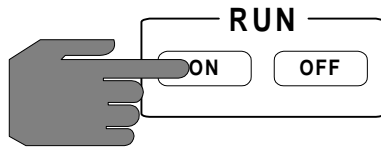

WARNING

Inform persons around the machine that your hands are in the laminator.

d) Raise the pull roller on the Explorer 107.

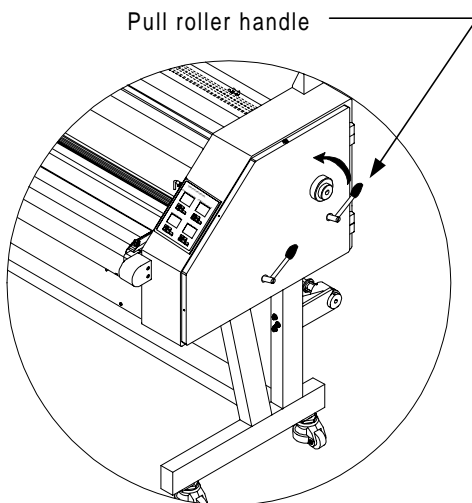

f) Have a person manually turn the upper pull roller of the Explorer 107 while you adjust the conveyor belts according to the sheet size.



INFORMATION

The belts will only move if the upper pull roller on the Explorer 107 is turning.



INFORMATION

This allows you to adjust the belts without feeding sheets through the laminator.

g) To adjust the belts, loosen the belt guide adjust knob and slide while the belts are moving.

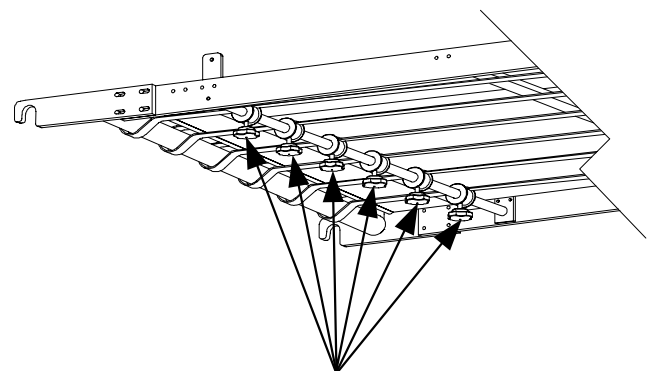

e) Depress an **E-STOP** before performing the next stop.

Belt guide adjust knobs



INFORMATION

All five belts should fall within the width of the sheet.

h) Secure the belt guide adjust knobs when finished.

i) Lower the pull roller on the Explorer 107 and close the front safety shield.

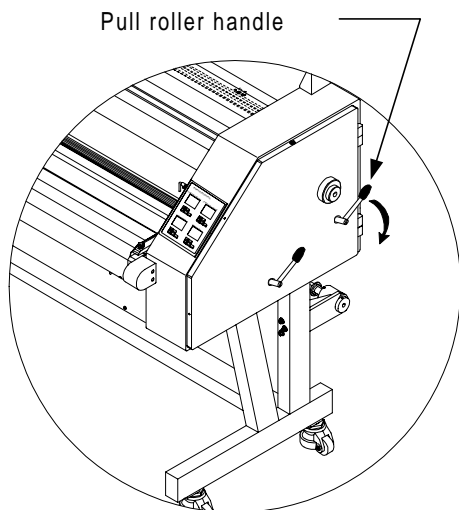

j) Press **RUN** on the feeder control panel.

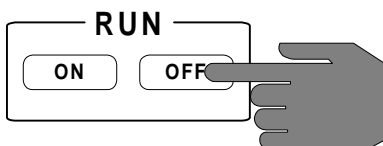

j) Slide the feeding head unit forward until 1/32 in. of the left and right paper spring plates is over the sheet stack.

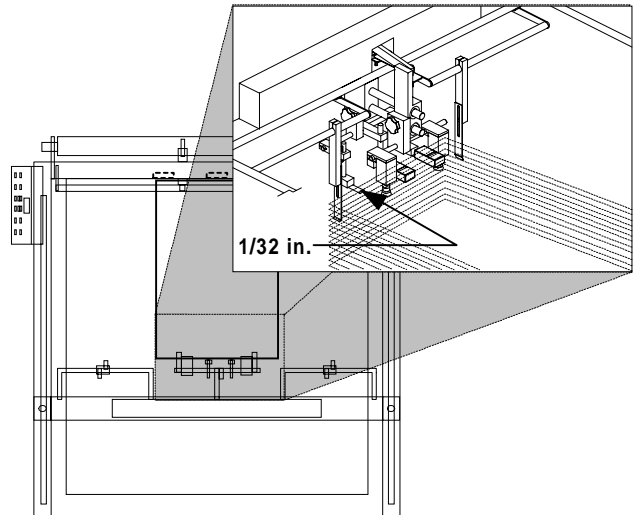

k) Adjust the rear left and rear right guides flush against the sheet stack.

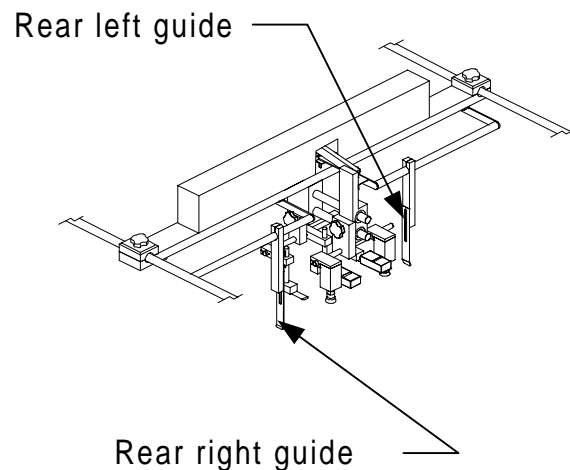

6.3 Making the adjustments

a) Adjust the sheet blower center of the sheet stack and approximately 1/2 in below the top.

b) Adjust the master nozzle air rate control valve for proper air flow strenght.

c) Adjust the left and right paper spring plate for adequate pressure.



INFORMATION

For heavy paper use more spring pressure and for lighter paper use less spring pressure.

d) Ensure the suction cups are perpendicular to the sheet stack.

e) Adjust the vacuum cups height according to the weight of the sheets.

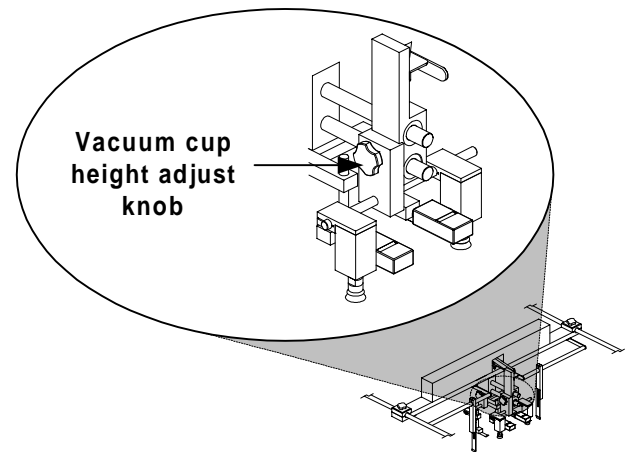
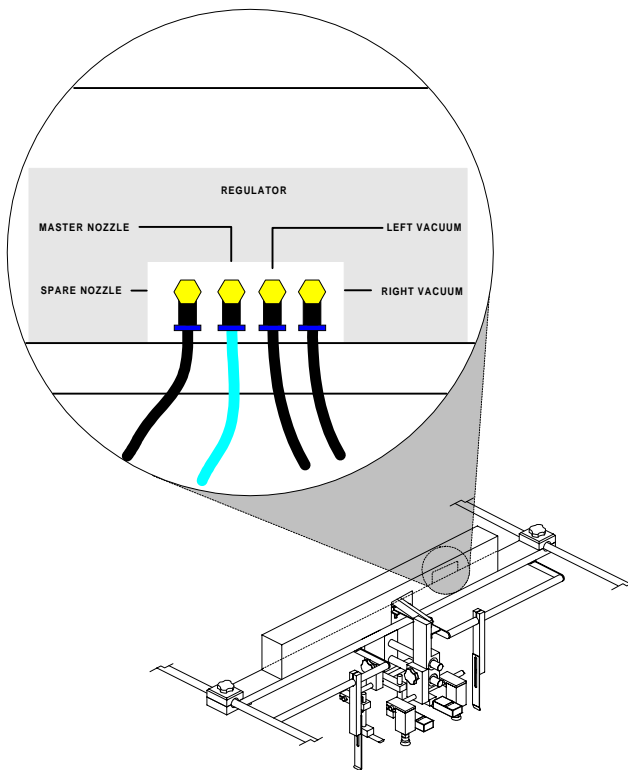

INFORMATION

The sheet blower should fan approximately 12 - 15 sheets. Varies due to paper weight.





WARNING

Do not set the suction cup too low where the cups jam into the sheet stack! You can cause damage to the suction cups.

f) Adjust the two feeding rollers.

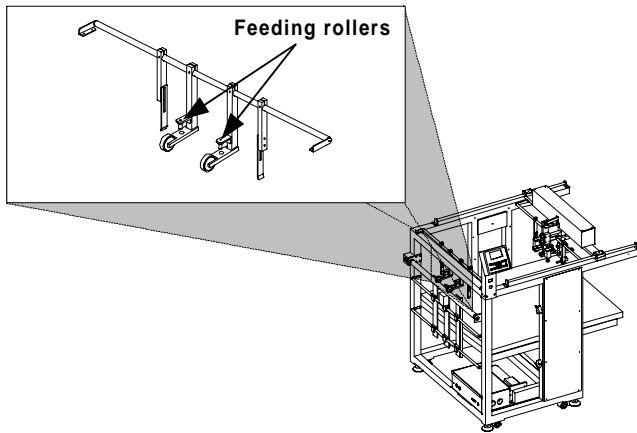
6.4 Setting the controls



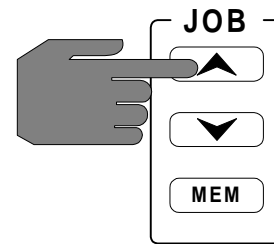

a) Press **JOB**  if you have the parameters for this sheet size and desired gap stored in a job location.

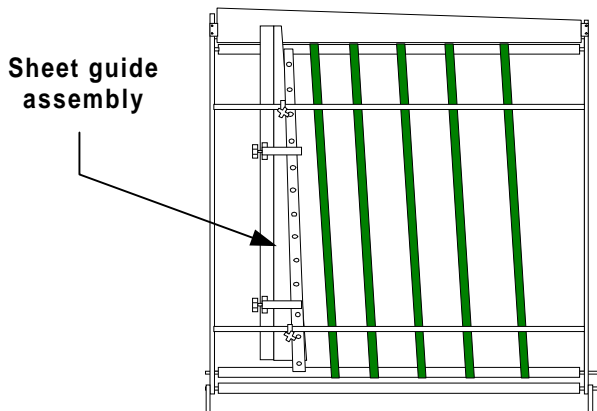

g) Adjust the sheet guide assembly.



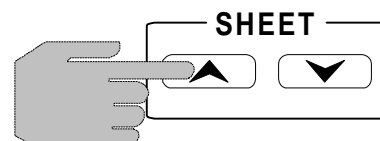

b) If you entered a job number, skip to step e, if not proceed with next step.

c) Press **SHEET**  or **SHEET**  to enter the sheet size on the sheet table.

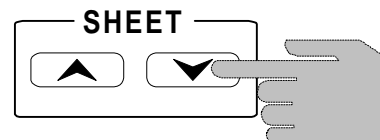

or



d) Press **GAP**  or **GAP**  to set the gap between sheets.

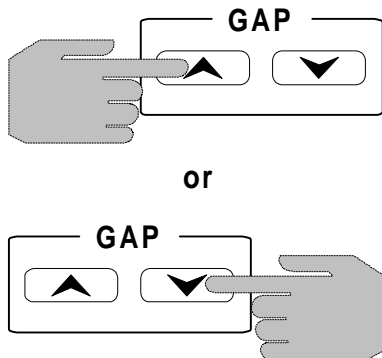

g) Press  under **MOTOR SPEED**.

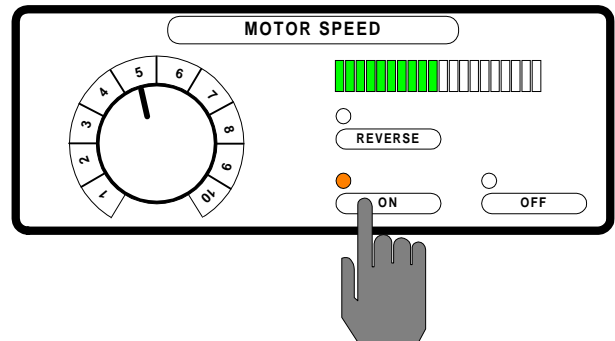

e) Press **VACUUM** .

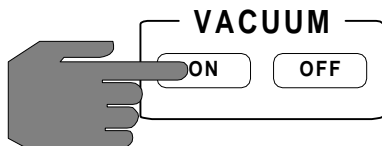

INFORMATION

The feeder will start when the laminator starts.

h) It may be necessary to make adjustments to the GAP, sheet blower, suction cup height, feeding rollers, speed (on the Explorer 107) and/ or sheet guide assembly during the run process.

f) Press **RUN** .

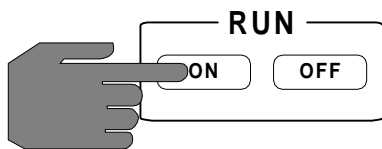

This page intentionally left blank.

Section 7 Troubleshooting

7.1 Troubleshooting Guide



WARNING

Do not wear ties, loose fit clothing or dangling jewelry while operating or servicing the feeder. These items can get caught in the machine and choke you or you can be crushed.

As an operator, you can perform simple troubleshooting to correct typical problems.



DANGER

At no time should you remove any covers or panels in an attempt to perform repairs or adjustments.



DANGER

At no time should you attempt to override any of the limit switches.

The chart on page 7-2 will assist you with minor repairs to the feeder. Refer to **Chart 7.1.1 Troubleshooting Guide** chart

Any checks beyond the solutions listed in the Troubleshooting guide chart should be performed by a qualified service technician. Please call your local area service representative.



ELECTRICAL SHOCK

Do not remove the cabinet covers. You can be severely shocked or killed!

Chart 7.1.1 Troubleshooting guide chart

Problem	Solution
Power is not on	<ul style="list-style-type: none"> • Ensure unit is properly plugged in. • Check for blown circuit fuses.
Power is ON, but the feeder does not operate.	<ul style="list-style-type: none"> • Check the connection of the encoder cable. • Verify that an E-STOP on the Explorer 107 is not depressed. • Ensure the pull rollers of the Explorer 107 are lowered.
Feeding head unit motor is not operating	<ul style="list-style-type: none"> • Check for blown Motor Fuse. • Ensure the feeding head unit is at a proper position.
Vacuum cups are not functioning correctly.	<ul style="list-style-type: none"> • Adjust the air rate control valves for each cup. • Adjust air pressure on the main regulator. • Verify the compressor is adequate for the feeder.
The sheet slips on the conveyor.	<ul style="list-style-type: none"> • Check the spacing of the conveyor belts. • Ensure all metal balls are in the position bar.
The sheet is not being fed squarely into the laminator.	<ul style="list-style-type: none"> • Check the sheet guide position. • Check the vertical and horizontal guide adjustments. • Check for contact between the conveyor feed plates.
The sheets are not being supplied smoothly.	<ul style="list-style-type: none"> • Adjust the Master nozzle for proper air flow. • Make adjustments to the left and right paper spring plates.

Section 8 Maintenance

8.1 Maintenance Schedule

GBC's Digital Feeder requires minimal maintenance. However, regular maintenance is essential to keep any piece of precision machinery at peak performance. A maintenance schedule and a section of procedures are included in this section.



INFORMATION

Below is a recommended maintenance schedule. Before performing any of the steps listed, read through the procedures first. Please follow the instructions pertaining to the step you are performing.



WARNING

Do not wear ties, loose fit clothing or dangling jewelry while operating or servicing the feeder. These items can get caught in the machine and choke you or you can be crushed.



DANGER

At no time should remove any covers or panels in an attempt to perform repairs or adjustments.



INFORMATION

Improper maintenance, can result in poor output quality.

GBC offers Extended Maintenance Agreements.

The only maintenance required by the operator is to maintain clean air and overall cleanliness of the machine itself.

Daily

- Inspect the electrical cord for damage. (**If damaged, you should replace or repair it immediately**)
- Inspect the pneumatic hoses for damage. (**If damaged, you should replace or repair it immediately**)
- Inspect the encoder cable for damage. (**If damaged, you should replace or repair it immediately**)
- Empty the water trap (**If you do not use the feeder daily, empty the water trap weekly**)

Monthly

- Check the chain tension.
(**Performed by a qualified Service Technician**)
- Inspect the area around the machine for possible hazards
(**dust buildup, combustible items stored too close, etc.**)
- Clean and lubricate the feeding head unit slide bars.
(**makes sliding the feeding head unit easier**)

Semi-Annual

- Lubricate the chains, and gears.
(**Performed by a qualified Service Technician**)
- Check wire termination tightness.
(**Performed by a qualified Service Technician**)

8.2 Clean the cabinets and covers



**ELECTRICAL
SHOCK**

Remove power from the feeder before cleaning. You can be severely shocked, killed or cause a fire.

- a) Use a damp cotton terry cloth (water only), to clean the exterior of the feeder.

- b) If water is not strong enough, you may use a mild dish washing detergent with water and a cotton terry cloth.



**ELECTRICAL
SHOCK**

Do not use liquid or aerosol cleaners on the feeder. Do not spill liquid of any kind on the feeder. You can be severely shocked, killed or cause a fire. Use only a damp cloth for cleaning unless other wise specified.

8.3 Cleaning the control panel



ELECTRICAL SHOCK

Remove power from the feeder before cleaning. You can be severely shocked, killed or cause a fire.

- a) Use only a slightly damp (water only) non abrasive cloth.



ELECTRICAL SHOCK

Do not use liquid or aerosol cleaners on the feeder. Do not spill liquid of any kind on the feeder. You can be severely shocked, killed or cause a fire. Use only a damp cloth for cleaning unless other wise specified.

8.4 Emptying the water trap

The water trap on the feeder is designed to catch the overflow of moisture from the compressor. This is the last prevention of moisture from getting to the pneumatic components.

It is essential that this water trap be emptied on a daily to weekly basis depending on usage. If your compressor in not equipped with a moisture trap device, this procedure should be performed daily.

- a) With a terry cloth towel, press up on the relief pin below the water trap bubble.

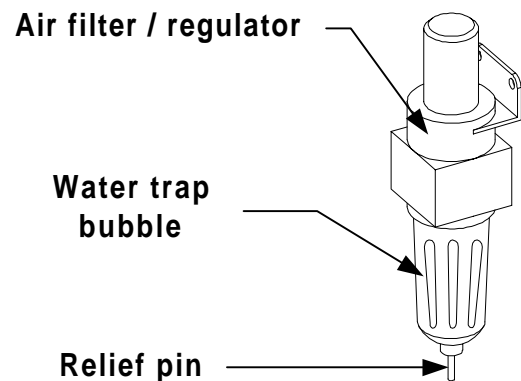

- b) If an excessive amount (more than a 1/5 full) hold a cup under the relief pin to catch most of the water.

This page intentionally left blank.