

DIGITAL CUTTER OPERATION & MAINTENANCE MANUAL

© February 2000 GBC Pro-Tech

Do not duplicate without written permission.

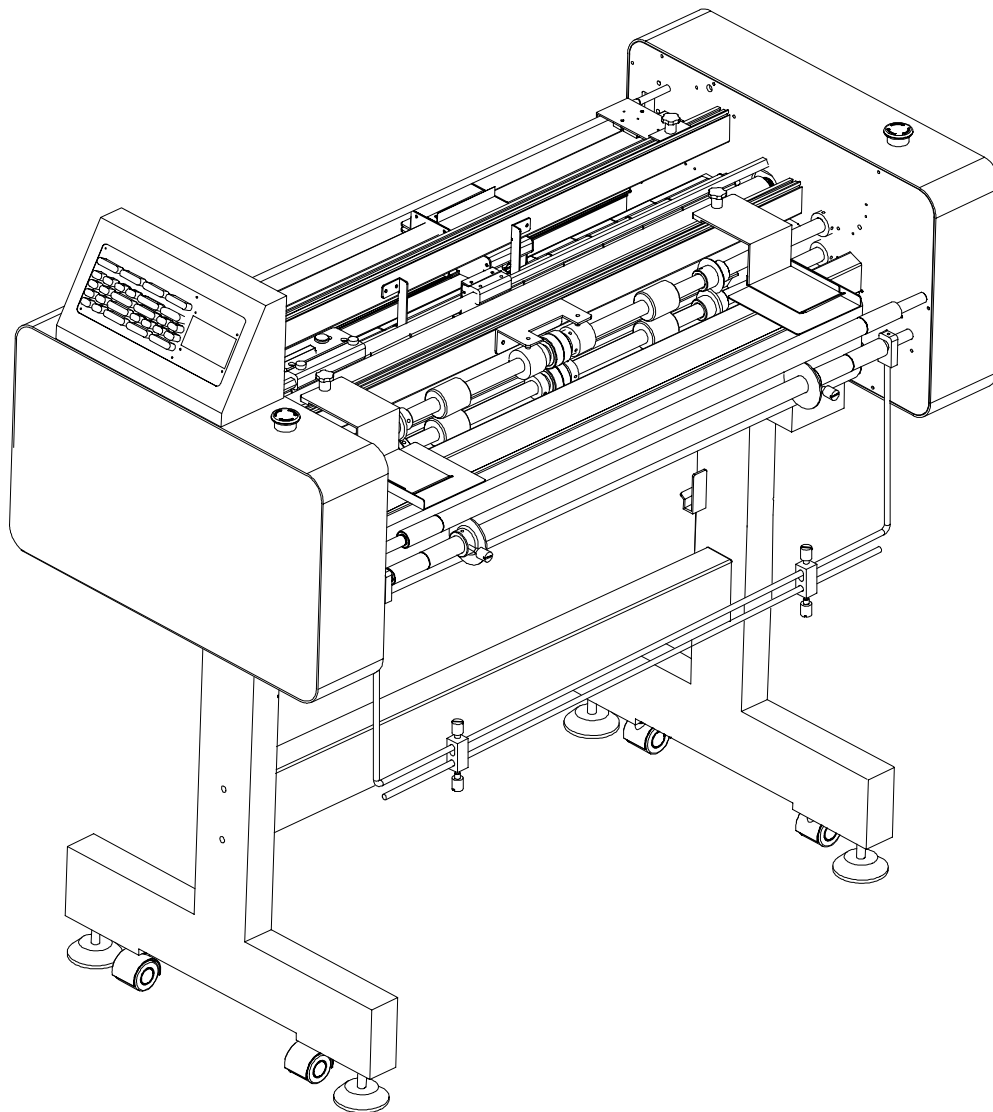

Revision :
Part number : 930 - 043

GBC Pro - Tech
4151 Anderson Road
DeForest, WI 53532
Ph: (608) 246 - 8844
Fx: (608) 246 - 8645







Read Me File

The information in this publication is provided for reference and is believed to be accurate and complete. GBC Pro - Tech is not liable for errors in this publication or for incidental or consequential damage in connection with the furnishing or use of the information in this publication, including, but not limited to, any implied warranty of fitness or merchantability for any particular use.

GBC Pro - Tech reserves the right to make changes to this publication and to the products described in it without notice. All specifications and information concerning products are subject to change without notice.

Reference in this publication to information or products protected by copyright or patent does not convey any license under the rights of GBC Pro - Tech or others. GBC Pro - Tech assumes no liability arising from infringements of patents or any other rights of third parties.

This publication is copyrighted © 2000 by GBC Pro - Tech. All rights reserved. The information contained in this publication is proprietary and may not be reproduced, stored, transmitted, or transferred, in whole or in part, in any form without the prior and express written permission of GBC Pro - Tech.

The following information will explain how to move around within the electronic version of this publication. The hand will change to a pointer finger identifying hyperlinked areas. When moving from page to page, use  to return to the **first PAGE**, use  to advance to the **last PAGE**, use  to **go back one PAGE** and use  to **advance one PAGE**. When moving from view to view, use  to **return** to a previous **VIEW** and use  to **advance** to the next **VIEW**.

Should you find an error within this publication or would like to make a suggestion, please utilize the fax correspondence sheet following the Read Me file and fax it to the number provided. Your comments and help will ensure up to date information. Thank you.

This page intentionally left blank.

Fax Correspondence

Fax number : (608) 246 - 8645

Date : _____

To : Sean Flood @ GBC Pro - Tech
4151 Anderson Road
DeForest, WI 53532

From : _____

Company : _____

Address : _____

Phone number : (_____) _____ Fax number : (_____) _____

Re : Digital Cutter Operations and Maintenance Manual (930 - 043)

Section #: _____ Page #: _____

Correction (s): _____

Additional comments: _____

This page intentionally left blank.

Table of Contents

Section 1: Safety

1.1 Symbols1 - 1

1.2 Safety features1 - 1

1.3 Installation1 - 3

1.4 Operations1 - 6

1.5 Applications1 - 8

1.6 Troubleshooting1 - 9

1.7 Maintenance1 - 10

1.8 Label Explanation1 - 11

 Figure 1.8.1 Label Location1 - 12

Section 2: Warranty

2.1 Limited warranty information2 - 1

2.2 Exclusions to the warranty2 - 1

Section 3: Specifications

3.1 General	3 - 1
3.2 Consumables.....	3 - 1
3.3 Function	3 - 2
3.4 Electrical	3 - 2
3.5 Dimensions	3 - 3
Figure 3.5.1 Digital Cutter	3 - 3
Figure 3.5.2 Stacker table	3 - 4

Section 4: Installation

4.1 Pre-installation check list	4 - 1
Figure 4.1.3 Suggested floor layout	4 - 2
4.2 Unpacking	4 - 3
4.3 Shrink wrapped	4 - 3

4.4 Crated4 - 4

4.5 Cutter positioning4 - 6

4.6 Leveling4 - 7

4.7 Connecting power/ air4 - 8

4.8 Safety check4 - 9

4.9 Control panel check4 - 12

4.10 Installing the catcher4 - 22

4.11 Installing the stacker4 - 23

Section 5: Operations

5.1 Control panel5 - 1

 Figure 5.1.1 Control panel5 - 1

5.2 Emergency5 - 9

5.3 Job programming5 - 10

Section 6: Applications

6.1 Webbing6 - 1

6.2 Manual function6 - 4

6.3 Sheeting function6 - 6

6.4 Web function6 - 7

6.5 Crop mark function6 - 9

Section 7: Troubleshooting

7.1 Troubleshooting guide7 - 1

7.1.1 Troubleshooting guide chart7 - 2

Section 8: Maintenance

8.1 Maintenance schedule8 - 1

8.2 Cleaning the rollers8 - 2

8.3 Clean the cabinets and covers8 - 3

8.4 Cleaning the control panel8 - 4

This page intentionally left blank.

Section 1 Safety



CAUTION

Do not attempt to operate your Digital Cutter until you have read this section carefully!

Your safety, as well as the safety of others, is important to GBC Pro - Tech. This section contains important safety information.

The following symbols are used throughout this manual to indicate **Information**, **Caution**, **Warning**, **Danger** and **Electrical Shock** conditions.

1.1 Symbols



INFORMATION

Indicates helpful information that should be considered before, during, or after an action, step or procedure is given.



CAUTION

Indicates a potentially hazardous situation which, if not avoided, could result in minor or moderate injury, or alerts against unsafe practices or alerts against actions which could damage the product.



WARNING

Indicates a potentially hazardous situation which, if not avoided, could result in serious injury.



DANGER

Indicates an imminently hazardous situation which, if not avoided, could result in death or serious injury.



ELECTRICAL SHOCK

Indicates an electrical shock situation which, if not avoided, could result in serious paralysis of the body or death.

1.2 Safety features

The Digital Cutter has been designed with safety as a primary consideration; however, you must become thoroughly familiar with the controls, proper operation, proper service procedures and safety features of the machine before using or servicing the unit.

**INFORMATION**

Only a qualified service technician should perform any procedure requiring the cabinet covers to be removed.

The word qualified is defined below;

Qualified ;

- Any engineer that has experience with electrical and mechanical design of lamination equipment. The engineers should be fully aware of all aspects of safety with regards to lamination equipment.

- Any commissioning or service engineer must be of competent nature, trained and qualified to GBC Pro-Tech standards to fulfill that job. This person will have completed and passed the full service training course from GBC Pro-Tech.

- Any GBC Technician, GBC Specialist, and / or GBC Pro-Tech Technician that has been through the GBC Pro-Tech service training course.

An important feature of the Digital Cutter is the safety latch and interlock. The front safety shield is equipped with one safety latch and one locator pin. When the safety latch is not in the locked position, the motor is disabled. Refer to **Figure 1.2.1**

**WARNING**

Caution should always be exercised when using the Digital Cutter with the safety shield in the raised position. You can be seriously hurt or injured!

**DANGER**

At no time should you attempt to over ride the safety latch on the machine.

Figure 1.2.1 Safety latch / locator pin

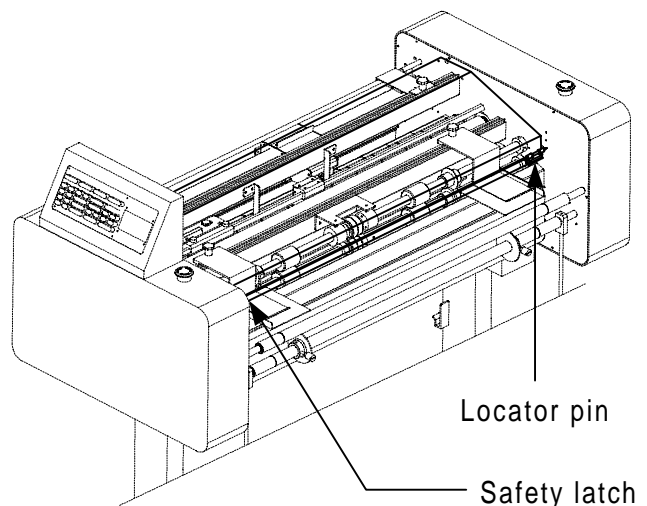

The Digital Cutter is equipped with two **EMERGENCY STOPS (E-STOP)** located on top of each side cabinet on the machine . Refer to **Figure 1.2.3**

Figure 1.2.2 Emergency stops

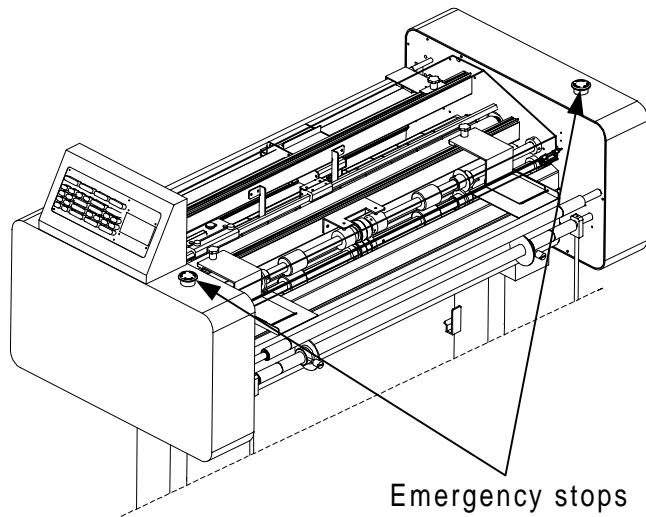

To continue operation, both **E-STOPS** must be in the up position. To reset the **E-STOP**, twist the button 1/4 turn clockwise.

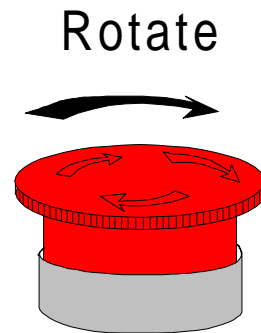

INFORMATION

The machine will only operate with both **E-STOPS** in the up position and the safety shield in the fully closed position.

1.3 Installation

The following symbols are positioned at various points in **Section 4 Installation**.

To engage the **EMERGENCY STOP** feature, press down. Either of these, when engaged, removes power to the motor.

Push down

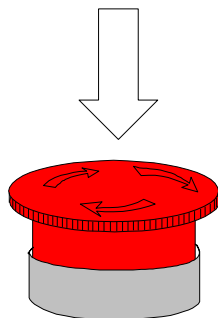

CAUTION

Failure to follow the pre-installation check list can result in damage to the cutter.



INFORMATION

Air must be controllable through an air regulator or an air rate control valve.

**WARNING**

The Digital Cutter is a large and heavy piece of equipment. It is necessary to employ **LICENSED RIGGERS ONLY** to move the machine. The machine is not designed to be tipped up or sideways in any way. Such action disturbs the exact alignment of the moving parts of the machine and requires extensive realignment. You can be crushed or seriously injured.

**INFORMATION**

Depending on the destination and customer preference, the Digital Cutter may be shipped by various methods. The machine may arrive shrink wrapped or in a plywood crate on a skid. Please follow the unpacking procedure that pertains to your method of shipment.

**INFORMATION**

ALL SHIPMENTS ARE EX-WORKS. At our dock, title passes to the buyer. Please review your insurance coverage prior to shipment, as you are responsible for all subsequent freight charges and risks.

**CAUTION**

Do not use a knife or other sharp objects to remove the strapping / and ties from around the machine. You can cause damage to the equipment.

**INFORMATION**

Before signing the Bill of Lading, you should inspect the crate and / or pallet for signs of damage or missing items; if applicable, make note of this on the Bill of Lading.

**WARNING**

Do not attempt to move the Digital Cutter across anything other than a flat level surface . You can be crushed or seriously injured.

**WARNING**

The unpacking process requires at least two people. You can be severely injured, crushed or cause damage to the equipment.

**CAUTION**

Do not allow the top to fall into the crate. It can damage the cutter.



INFORMATION

Do not put packing screws on the floor. They can cause problems when trying to roll the cutter into position or you can become injured if stepped on.



INFORMATION

Improper leveling, will result in poor output quality.



CAUTION

A second person must support the side labeled 5 in Figure 4.5.1 It can fall and damage the cutter or cause harm to you and others.



WARNING

Do not wear ties, loose fit clothing or dangling jewelry while operating or servicing the cutter. These items can get caught in the machine and choke you or you can be cut or crushed.



WARNING

If a safety feature is not functioning properly, contact your local service representative immediately



INFORMATION

GBC Pro-Tech's warranty does not cover malfunction of the equipment due to mishandling and / or tipping. GBC Pro-Tech bears no responsibility for personal injury or damage due to moving the cutter improperly.



INFORMATION

Only the safety latch (on the left) will stop the machine. The locator pin (on the right) is to secure the right side of the safety shield.



INFORMATION

About recycling: The crate components can be reused for shipping the machine again or can be disassembled and the wood and screws recycled. The shrink wrap is not recyclable, so it must be discarded.



DANGER

At no time should you attempt to over ride any of the safety devices on the cutter.

**INFORMATION**

The machine will only operate with the safety shield in the fully closed position.

**INFORMATION**

With respect to unit of measurement, Length  in SHEETING mode will give 1/32 inch increments by pressing it twice or sometimes once. This is due to the the microprocessor taking the decimal into consideration during the calculation process.

1.4 Operations

The following symbols are positioned at various points in **Section 5 Operations**.

**WARNING**

Do not wear ties, loose fit clothing or dangling jewelry while operating or servicing the cutter. These items can get caught in the machine and choke you or you can be cut or crushed.

**INFORMATION**

Speed can be adjusted regardless of the mode selection.

**DANGER**

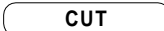
Keep hands and fingers out from the path of the rotary cutting head when using  under MANUAL mode.

**INFORMATION**

Unit of measurement will always be inches until mm is selected.

**INFORMATION**



The machine will only operate with both E-STOPS in the up position and the safety shield in the fully closed position.

**INFORMATION**

When a negative value is set for the front and rear margins, the blade will cut into the product.

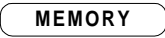

INFORMATION

JOB  and JOB  are also used in conjunction with the 



INFORMATION

If the cutter is line with a laminator, be sure to stop the laminator when possible.



INFORMATION

This operational function has no regards to sheet size or paper to paper sensors.



INFORMATION

Power to the motor is removed when the safety shield is not in the fully locked position.



INFORMATION

This operational function requires that you follow the procedure outlined in Section 6.4 Read Mark function.



INFORMATION

Follow the suggested starting procedure for the laminator after an emergency situation.



INFORMATION

The counter only counts sheets when operating in AUTO mode and SHEETING mode.



INFORMATION

Engaging an E-STOP does not affect any of the parameters on the control panel.



INFORMATION

When an EMERGENCY STOP is engaged, all motion stops.



INFORMATION

FRONT MARGIN, REAR MARGIN, SENSOR INTENSITY, UNIT, SPEED and LENGTH are parameters that can be stored.

**INFORMATION**

Values will reflect your desired settings.

**WARNING**

Exercise extreme caution when adjusting the left / right trimmers. Sharp blades can cut you!

1.5 Applications

The following symbols are positioned at various points in **Section 6 Applications**.

**INFORMATION**

Set the lower trimmers first. Then set the upper trimmers firmly against the lower trimmers.

**WARNING**

Do not wear ties, loose fit clothing or dangling jewelry while operating or servicing the cutter. These items can get caught in the machine and choke you or you can be cut or crushed.

**CAUTION**

Ensure that the trimmed web is guided down to the catcher. If not, the trimmed web may wrap around the rollers and cause problems with the operation.

**INFORMATION**

The machine will only operate with both E-STOPS in the up position and the safety shield in the fully closed position.

**INFORMATION**

The rotary cutting head sensors confine the left and right movement of the rotary cutting head unit.

**WARNING**

Caution should always be exercised when using the Digital Cutter with the safety shield in the raised position. You can be seriously hurt or injured!

**INFORMATION**

Speed may be changed at anytime regardless of MODE selection.



INFORMATION

Use **REVERSE** if you should pass your desired cutting point.



WARNING

Do not wear ties, loose fitting clothes or dangling jewelry while operating or servicing the cutter. These items can get caught in the nip and choke you or you can be crushed.



DANGER

Ensure the path of the cutting head is clear. You can be cut or damage the cutting head.



DANGER

At no time should you attempt to perform any repairs requiring the removal of the cabinet covers!



INFORMATION

When a negative value is set for the front and rear margins, the blade will cut into the paper.



DANGER

At no time should you attempt to over ride the safety latch on the machine.



INFORMATION

Approximately a 3 or 4 should be used for Matte film and a 1 or 2 for transparent film.



ELECTRICAL SHOCK

Do not remove the cabinet covers. You can be severely shocked or killed!

1.6 Troubleshooting

The following symbols are positioned at various points in **Section 7 Troubleshooting**.

1.7 Maintenance

The following symbols are positioned at various points in **Section 8 Maintenance**.



ELECTRICAL SHOCK

Remove power from the machine before servicing. You can be severely shocked, killed or cause a fire.



WARNING

Do not wear ties, loose fitting clothes or dangling jewelry while operating or servicing the cutter. These items can get caught in the nip and choke you or you can be crushed.



CAUTION

Never clean the rollers with sharp or pointed objects. You may put irreparable cuts into the rollers.



INFORMATION

Improper maintenance, can result in poor output quality.



CAUTION

Do NOT pick or pull heat activated adhesive off the rolls when they are cold. You can cause irreparable damage to the laminating rolls.



INFORMATION

Below is a recommended maintenance schedule. Before performing any of the steps listed, read through the procedures first. Please follow the instructions pertaining to the step you are performing.



WARNING

Caution should always be exercised when using the Digital Cutter with the safety shield in the raised position. You can be seriously hurt or injured!



INFORMATION

The machine will only operate with both E-STOPS in the up position and the safety shield in the fully closed position.

1.8 Label locations

Cautions / Warning Label Locations

Posted at various locations on the Digital Cutter are important safety labels. **Pay careful attention to these labels at all times!** Figure 1.8.1 illustrates the location of each of these labels.



ELECTRICAL SHOCK

Remove power from the cutter before cleaning. You can be severely shocked, killed or cause a fire.



ELECTRICAL SHOCK

Do not use liquid or aerosol cleaners on the cutter. Do not spill liquid of any kind on the cutter. You can be severely shocked, killed or cause a fire. Use only a damp cloth for cleaning unless other wise specified.

▲ MUCHO CUIDADO	▲ MUCHO CUIDADO	▲ WARNING	▲ WAARSCHUWING	▲ ATTENZIONE	▲ WARNUNG	
Riesgo de choque eléctrico. No abra. Además, no hay piezas reparables para el usuario. Mantenimiento solamente para personal calificado.	Risque de secousse électrique. Ne pas ouvrir. Pas de pièces réparables par l'utilisateur. Entretien par personnel qualifié.		Electrical shock hazard. Do not open. No user serviceable parts inside. Refer servicing to qualified service personnel.	Kies op elektrische schok. Niet openen. Bewaagden door gebroek te repareren onderdelen. Doet bevoegd service personeel laten repareren.	Pericolo di scossa elettrica. Nessuna parte riparabile dall'utente. Chiamare un servizio di riparazioni qualificato.	Spannungsfahren ge. Falls Nicht öffnen. Enthält keine vom Endverbraucher zu wartende Teile. Für Service bitte an qualifiziertes Service Personal wenden.

(2) **ELECTRICAL SHOCK:** Electrical shock hazard. Electrical voltage behind panel.

▲ CUIDADO	▲ ATTENTION		▲ CAUTION	▲ WARNUNG
NAVAJA FILOSA.	LAME COUPANTE.		SHARP BLADE.	SCHARFE KLINGE
Mantener manos y dedos a distancia.	Tenir mains et doigts à l'écart.		Keep hands and clothing away.	Hande und finger ferhalten.

(1) **SHARP BLADE:** Sharp blade comes down. Keeps hands and fingers away.

Figure 1.8.1 Label locations

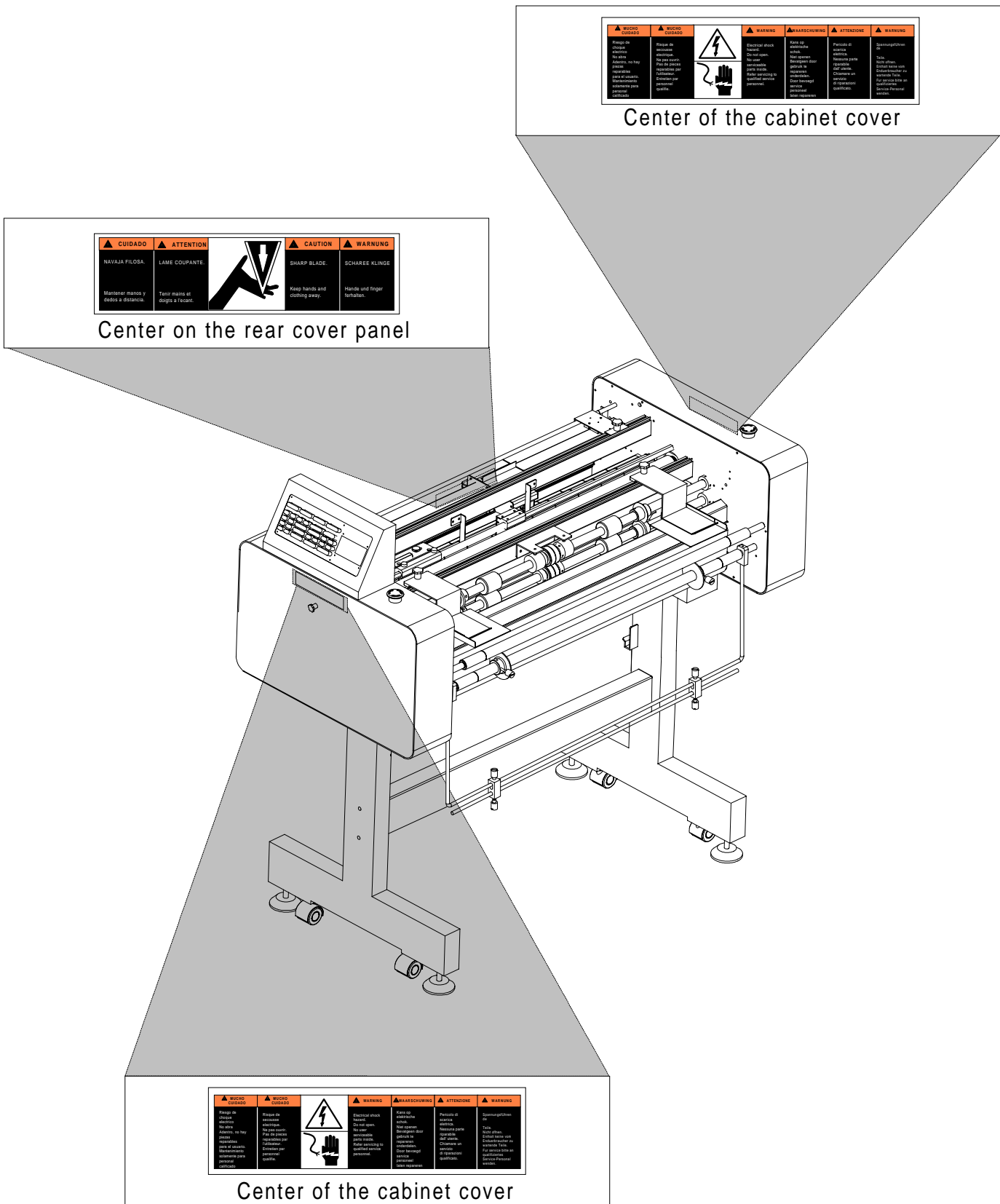

Section 2 Warranty

GBC Pro-Tech warrants the equipment sold is free from defects in material and workmanship for a period of **one (1) year parts and 90 days labor** from the date of installation. This warranty is the only warranty made by GBC Pro-Tech and cannot be modified or amended.

GBC Pro-Tech's sole and exclusive liability and the customer's sole and exclusive remedy under this warranty shall be, at GBC Pro-Tech's option, to repair or replace any such defective part or product. These remedies are only available if GBC Pro-Tech's examination of the product discloses to GBC Pro-Tech's satisfaction that such defects actually exist and were not caused by misuse, neglect, attempt to repair, unauthorized alteration or modification, incorrect line voltage, fire, accident, flood or other hazards.

2.1 Limited Warranty

This warranty specifically does not cover damage to the rollers caused by knives, razor blades, other sharp objects, failure caused by adhesives or improper use of the machine. **Warranty repair or replacement does not extend the warranty beyond the initial one year period from the date of delivery.**



CAUTION

Unauthorized customer alterations will void this warranty.

THE WARRANTY MADE HEREIN IS IN LIEU OF ALL OTHER WARRANTIES, EXPRESS OR IMPLIED, INCLUDING ANY WARRANTY OR MERCHANTABILITY OR FITNESS FOR A PARTICULAR PURPOSE. GBC PRO-TECH WILL NOT BE LIABLE FOR PROPERTY DAMAGE OR PERSONAL INJURY (UNLESS PRIMARILY CAUSED BY ITS NEGLIGENCE), LOSS OF PROFIT OR OTHER INCIDENTAL OR CONSEQUENTIAL DAMAGES ARISING OUT OF THE USE OR INABILITY TO USE THE EQUIPMENT.

2.2 Exclusions to the Warranty

This warranty specifically does not cover;

1. Damage to the rollers caused by knives, razor blades, other sharp objects or failure caused by adhesives.
2. Damage to the machine caused by lifting, tilting and/or any attempt to position the machine other than rolling on the installed castors on even surfaces.
3. Improper use of the machine.
4. Damage due from unqualified person(s) servicing the machine.

Qualified

- Any engineer that has experience with electrical and mechanical design of lamination equipment. The engineers should be fully aware of all aspects of safety with regards to lamination equipment.

- Any commissioning or service engineer must be of competent nature, trained and qualified to GBC Pro-Tech standards to fulfill that job. This person will have completed and passed the full service training course from GBC Pro-Tech.

- Any GBC Technician, GBC Specialist, and/or GBC Pro-Tech Technician that has been through the GBC Pro-Tech service training course.

Section 3: Specifications

Specifications provide all of the technical data for the Digital Cutter.

3.1 General

Description :

- High speed automatic cutter that can operate in-line with most roll laminators or as a stand alone unit.

Features :

- Interactive operation LCD module control panel
- Left and right slitting
- Adjustable width rotary cutting head
- Photo electric eye for crop mark detection
- 9 programmable job memory locations
- Large stacker table
- Convenient hanging scrap catcher

Operations :

- Manual cutting
- Sheet length cutting
- Sheet to sheet cutting
- Crop mark cutting

3.2 Consumables

Cutting thickness:

- Up to two layers of 10 mil film

Film Widths :

- 6.25 - 35.50 inches (16 - 90 cm)

Paper Widths :

- 6.25 - 35.50 inches (16 - 90 cm)

3.3 Function

Speed :

- 0 - 50 ft/m (0 - 15 m / min)

Motor :

- 1/2 horse power drive motor
- Bi-directional D.C. motor

Controls :

- Left side mounted control panel

Roll Design :

- High release silicone nip rollers

3.4 Electrical

United States :

- 110 VAC, 50/60 Hz, single phase, 10 amps.

Europe:

- 220 - 240 VAC, Wye 3 phase, 3 amps/ phase

Wattage consumption:

- 350 watts

Amperage draw :

- Drive motor = 7amps

D/C Voltage used:

- 24 vdc

3.5 Dimensions

Weight :

- Crated : 250 lbs. (113 kg.)
- Uncrated : 150 lbs. (68 kg.)

Dimensions :

- Crated : 61 in. (H) x 59 in. (W) x 36 in. (D)
(155 cm (H) x 150 cm (W) x 91 cm (D)
- Uncrated : 43 in. (H) x 51 in. (W) x 24 in. (D)
(109 cm (H) x 130 cm (W) x 61 cm (D)
Refer to **Figure 3.5.1 Digital Cutter**

Nip Height :

- 37 in. (94 cm)

Stacker table:

- 39.5 in. (W) x 43 in. (L)
(100 cm (W) x 109 cm (L)
Refer to **Figure 3.5.2 Stacker table**

Figure 3.5.1 Digital Cutter

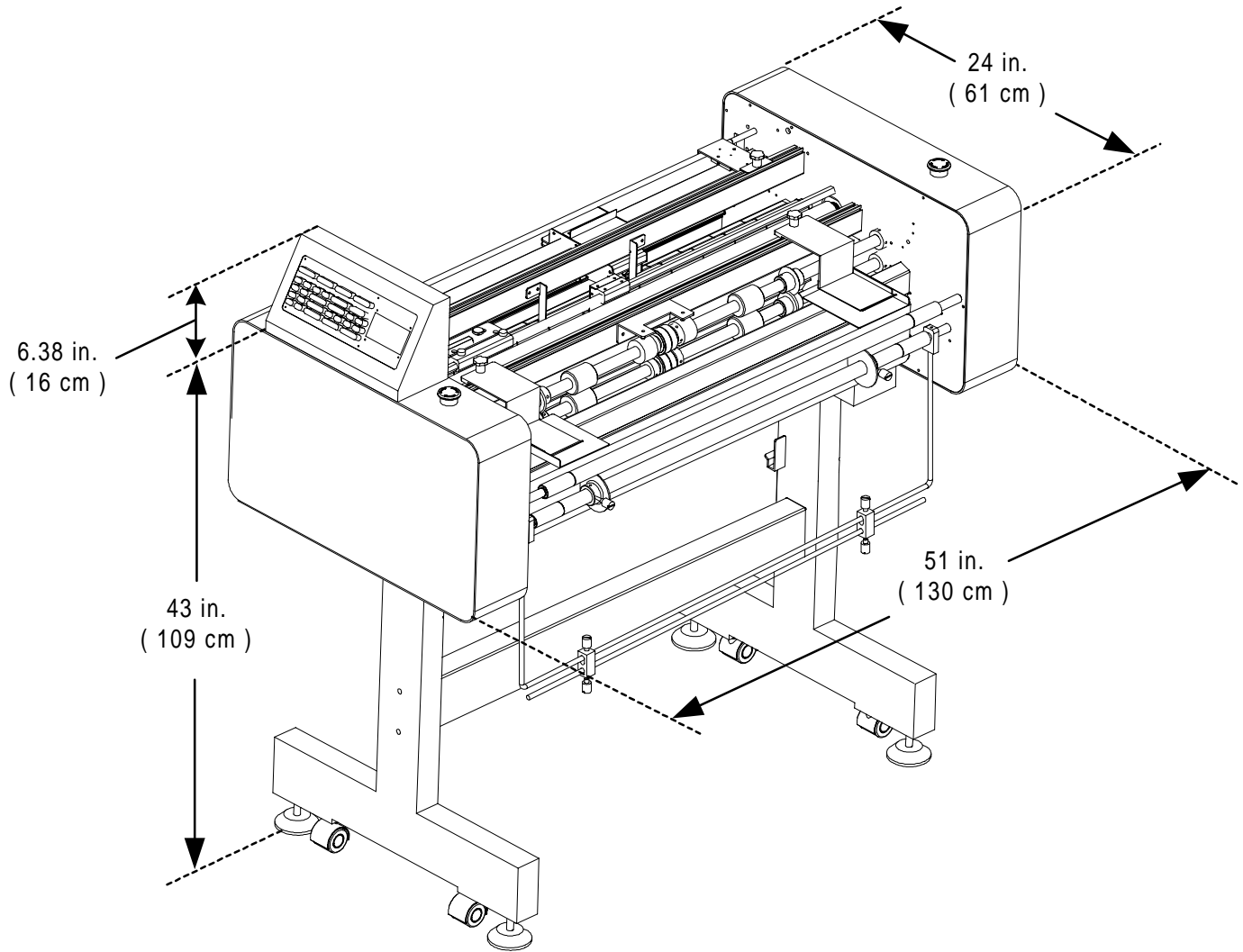
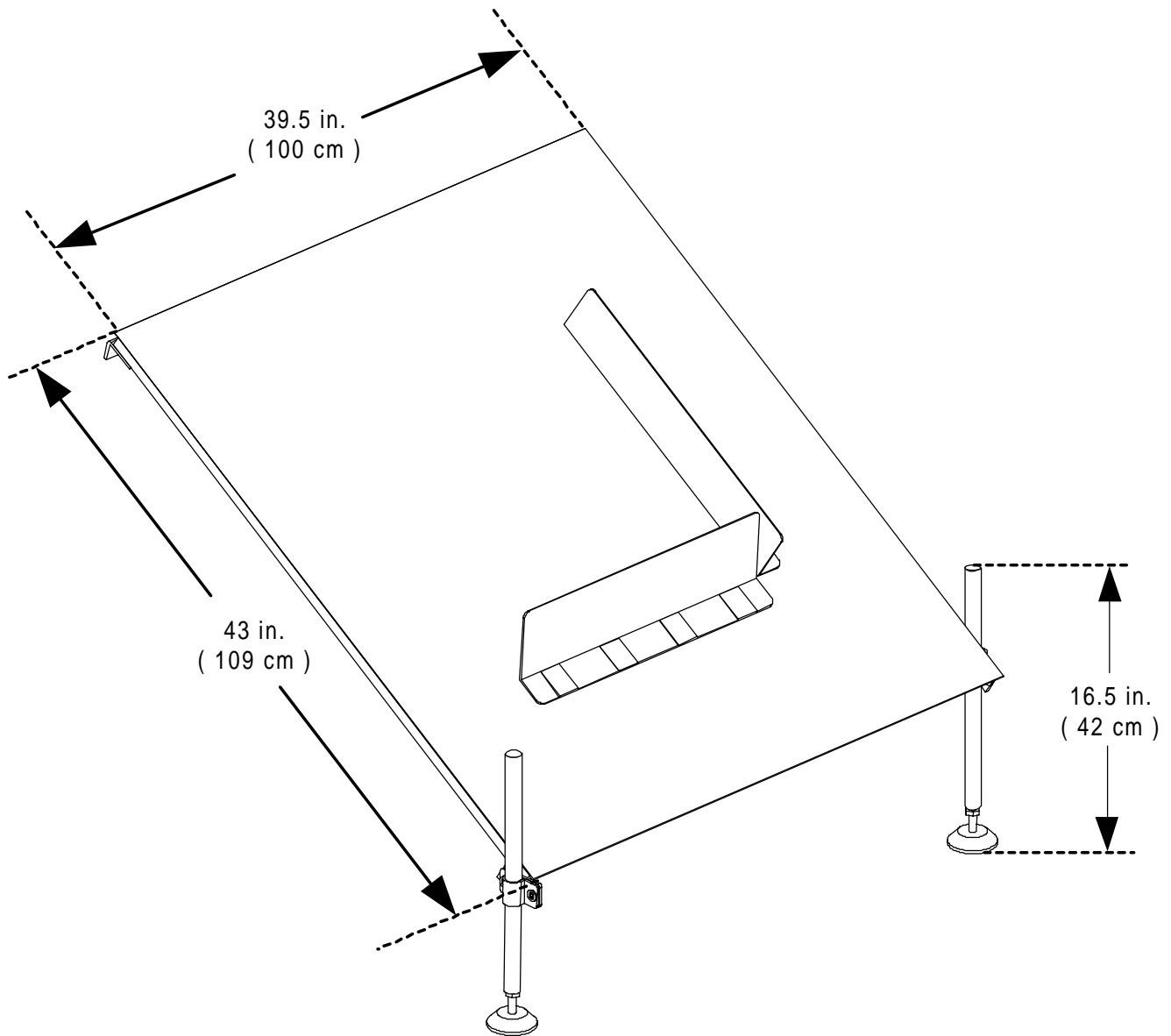

Figure 3.5.1 Stacker table



This page intentionally left blank.

Section 4 Installation

GBC Pro-Tech is committed to a program of ongoing product improvement. As a result, we are providing these instructions so you can insure that your new Digital Cutter is properly and securely unpacked, moved, and installed.

Before the Digital Cutter can be installed, there are a few requirements that must be met. Ensure that each of the requirements listed in the following pre-installation checklist are met before beginning installation.

- Electrical requirements: The Digital Cutter operates on 110 VAC, 10 amp service. The plug is standard two prong with a ground.
- Pneumatic requirements: 10 p.s.i. (If inline with a GBC Digital Feeder, use the outlet labeled Spare Nozzle on the feeder's head unit) Refer to your GBC Digital Feeder Operation and Maintenance Manual.



CAUTION

Failure to follow the pre-installation check list can result in damage to the cutter.



INFORMATION

Air must be controllable through an air regulator or an air rate control valve.

4.1 Pre-installation

- Are doorways and hallways wide enough for the Digital Cutter to be moved to the installation site?
- Is there ample room for the Digital Cutter?
- A work area must be established that allows for unrestricted movement around the Digital Cutter and provides space for efficient material flow. **Figure 4.1.1** illustrates a typical machine area layout.



WARNING

The Digital Cutter is a large and heavy piece of equipment. It is necessary to employ **LICENSED RIGGERS ONLY** to move the machine. The machine is not designed to be tipped up or sideways in any way. Such action disturbs the exact alignment of the moving parts of the machine and requires extensive realignment. You can be crushed or seriously injured.

Figure 4.1.1 Suggested Floor Layout

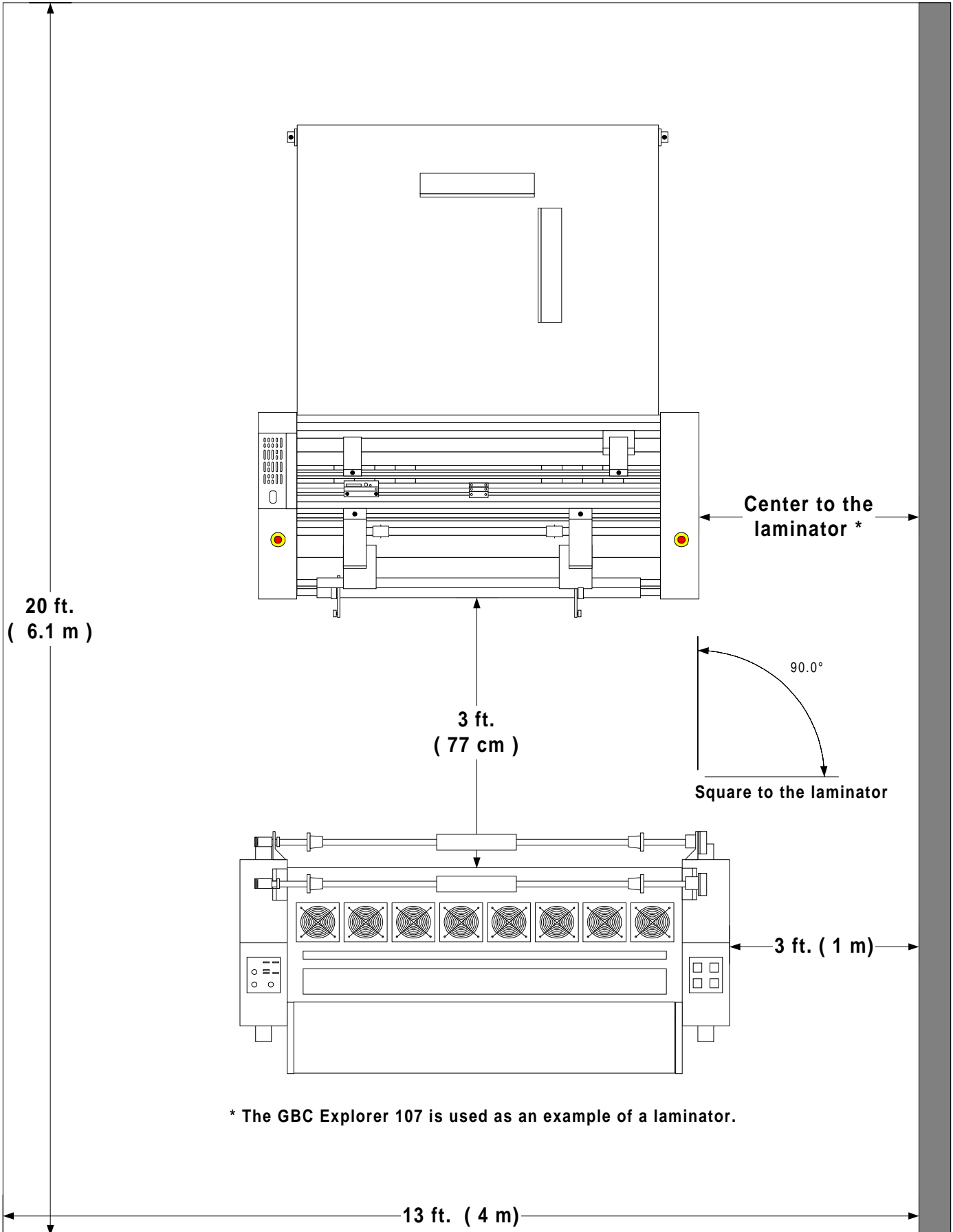

4.2 Unpacking



INFORMATION

ALL SHIPMENTS ARE EX-WORKS. At our dock, title passes to the buyer. Please review your insurance coverage prior to shipment, as you are responsible for all subsequent freight charges and risks.



INFORMATION

Before signing the Bill of Lading, you should inspect the crate and / or pallet for signs of damage or missing items; if applicable, make note of this on the Bill of Lading.



INFORMATION

Depending on the destination and customer preference, the Digital Cutter may be shipped by various methods. The machine may arrive shrink wrapped or in a plywood crate on a skid. Please follow the unpacking procedure that pertains to your method of shipment.



WARNING

The unpacking process requires at least two people. You can be severely injured, crushed or cause damage to the equipment.

With regards to your shipping methods, use one of the following procedures described to safely and properly unwrap / uncrate your cutter.

4.3 Shrink wrapped

a) Inspect the machine for any obvious shipping damages upon receipt.

b) Carefully unwrap the shrink wrap from around the Digital Cutter.



CAUTION

Do not use a knife or other sharp objects to remove the strapping / and ties from around the machine. You can cause damage to the equipment.

c) With another person, carefully wheel your Digital Cutter to the installation site.



WARNING

Do not attempt to move the Digital Cutter across anything other than a flat level surface . You can be crushed or seriously injured.



INFORMATION

Do not put packing screws on the floor. They can cause problems when trying to roll the cutter into position or you can become injured if stepped on.



CAUTION

A second person must support the side labeled 5 in Figure 4.5.1 It can fall and damage the cutter or cause harm to you and others.

4.4 Crated

Tools required

- # 2 Phillips head screwdriver
- Large adjustable wrench
- Crow bar
- A second person

To uncrate the cutter

a) Remove the top of the crate and then the sides in the order shown in **Figure 4.4.1**



CAUTION

Do not allow the top to fall into the crate. It can damage the cutter.

Figure 4.4.1 Disassembling of the crate

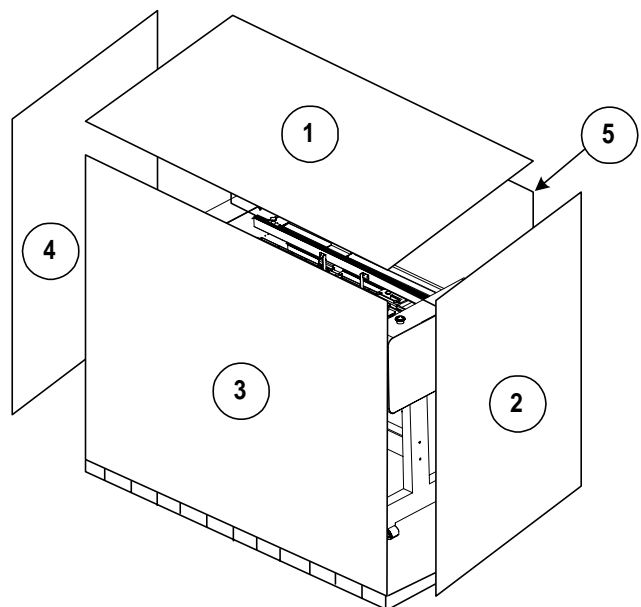

Removing the shrink wrap

- a) Gently unwrap the shrink wrap from around the cutter and stacker.



WARNING

Do not attempt to move the Digital Cutter across anything other than a flat level surface . You can be crushed or seriously injured.



CAUTION

Do not use a knife or other sharp objects to remove the strapping / ties from around the machine. You can cause damage to the equipment.



INFORMATION

GBC Pro-Tech's warranty does not cover malfunction of the equipment due to mishandling and / or tipping. GBC Pro-Tech bears no responsibility for personal injury or damage due to moving the cutter improperly.

Moving the laminator

- a) Have the cutter lifted from the skid and placed on the floor by licensed riggers.

- b) Remove any plastic strapping and/or packing paper taped to the machine.



WARNING

The Digital Cutter is a large and heavy piece of equipment. It is necessary to employ **LICENSED RIGGERS ONLY** to move the machine. The machine is not designed to be tipped up or sideways in any way. Such action disturbs the exact alignment of the moving parts of the machine and requires extensive realignment. You can be crushed or seriously injured.



CAUTION

Do not use a knife or other sharp objects to remove the strapping / ties from around the machine. You can cause damage to the equipment.

- c) Move all packing materials to a safe distance from the equipment and dispose of properly.

d) Use two people to carefully roll the cutter and stacker to the desired location.

a) Measure 3 feet (91 cm) from one side of the cutter to the laminator. Refer to **Figure 4.5.1 Squaring the cutter**



INFORMATION

About recycling: The crate components can be reused for shipping the machine again or can be disassembled and the wood and screws recycled. The shrink wrap is not recyclable, so it must be discarded.

e) Use **Figure 4.1.1** for the suggested floor layout.

Figure 4.5.1 Squaring the cutter

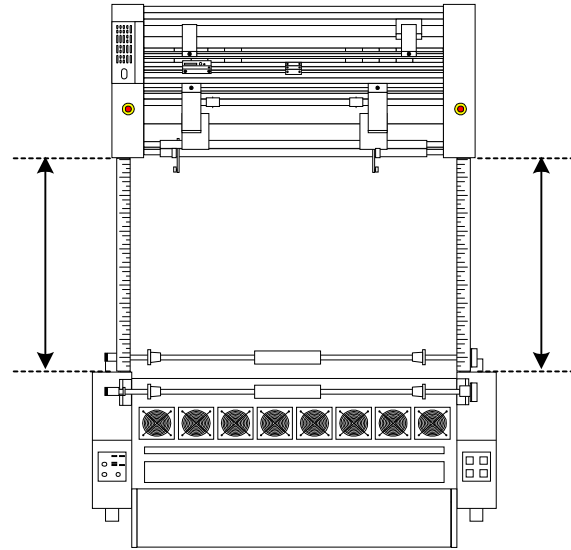

* The GBC Explorer 107 is used as an example of a laminator.

4.5 Cutter positioning

The Digital Cutter must be squared with the laminator. When two machines operate as one and are not squared to each other, skewing will occur.

b) Measure 3 feet (91 cm) from the other side of the cutter to the laminator. Refer to **Figure 4.5.1 Squaring the cutter**

Tools required

- Yard stick or tape measure
- A second person

c) Proceed to leveling the cutter.

4.6 Leveling

Leveling of the cutter is very important in the way the machine performs. Leveling is crucial to the tram (tracking) of the materials through the machine.



INFORMATION

Improper leveling, will result in poor output quality.

Tools required

- Torpedo level
- (2) 19 mm open end wrenches
- Second person

Front to back leveling

- Verify that the cutter has sufficient room around it to load film, walk around and service if necessary.
- Position the level on top of the control panel of the left cabinet. Refer to **Figure 4.6.1 Left side**

Figure 4.6.1 Left side

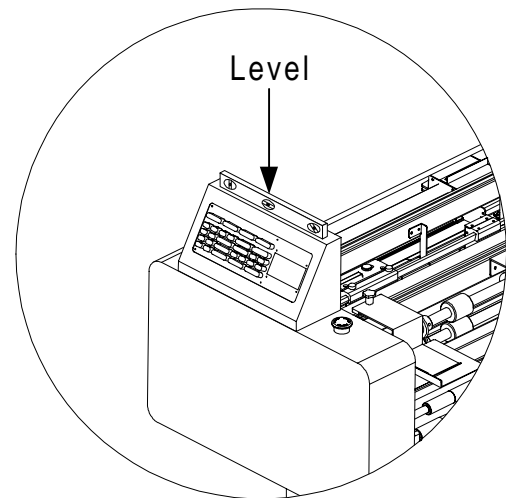

- With two 19 mm wrenches, adjust the foot bolts so that the left side is even from front to back. Refer to **Figure 4.6.2 Foot bolt**

Figure 4.6.2 Foot bolt

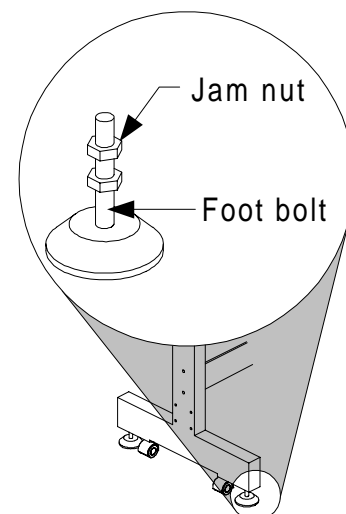

- Position the level on the right side cabinet. Refer to **Figure 4.6.3 Right side**

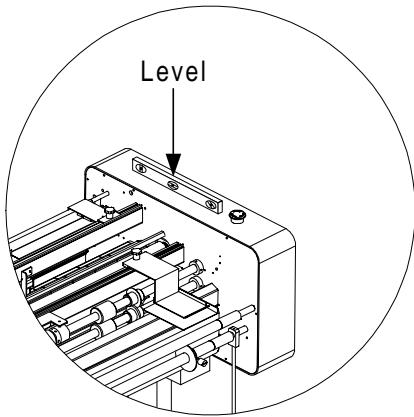
Figure 4.6.3 Right side

- e) With two 19 mm wrenches, adjust the foot bolts so that the right side is even from front to back. Refer to **Figure 4.6.2 Foot bolt**

Right to left leveling

- f) Position the level on the cross beam between the two legs. Refer to **Figure 4.6.4 Cross beam**

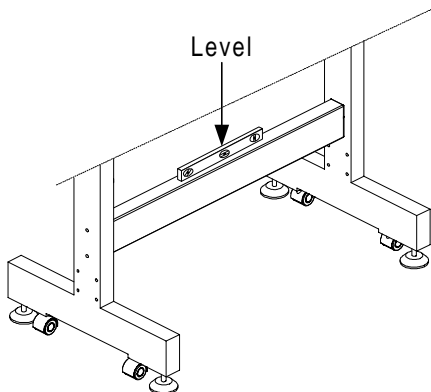
Figure 4.6.4 Cross beam

- g) With two 19 mm wrenches, adjust the foot bolts so that the right side is even from left to right. Refer to **Figure 4.6.2 Foot bolt**

- h) Verify that left, right and front to back are all still level then secure the foot bolts in position by turning the jam nut. Refer to **Figure 4.6.2 Foot bolt**

4.7 Connecting power/air

The cutters plug requires a grounded three prong receptacle.

- a) Insert the male plug into the proper female wall receptacle.
- b) Insert the 1/4 inch (2.54 cm) pneumatic tubing from a compressor to the cutter.

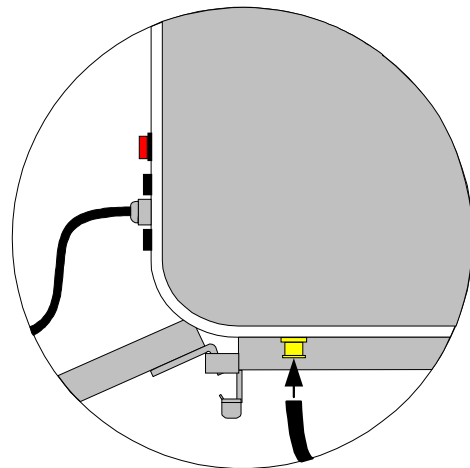

4.8 Safety check

The safety check will ensure that all safety devices and interlock switches are functioning properly. Plug the cutter into the proper receptacle. Air is not required at this point.

The stacker and catcher will be installed after the safety and function check has been completed.

b) Press **POWER** to “I”.

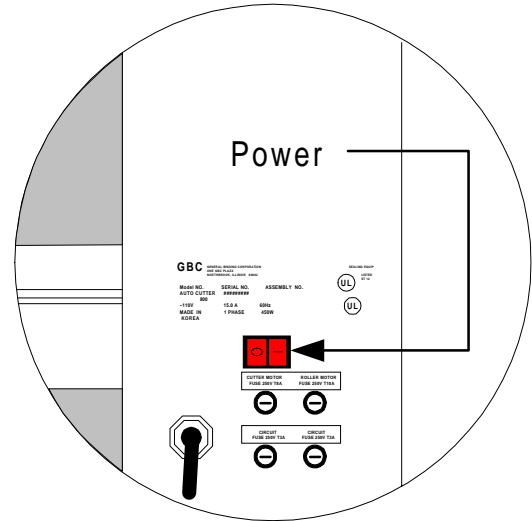

WARNING

Do not wear ties, loose fit clothing or dangling jewelry while operating or servicing the cutter. These items can get caught in the machine and choke you or you can be cut or crushed.

c) Press **MANUAL** on the control panel.

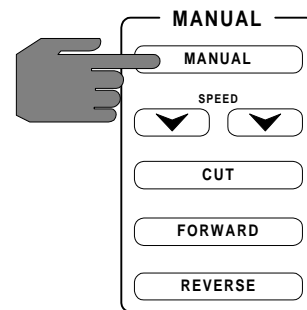

WARNING

If a safety feature is not functioning properly, contact your local service representative immediately

c) Press **SPEED** to “3” under **MANUAL**.

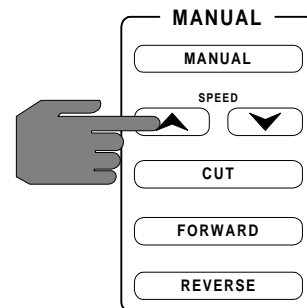

Front safety shield

a) Ensure an **E-Stop** is not depressed. If depressed, unlatch the **E-Stop**.

e) Press **AUTO** on the control panel.

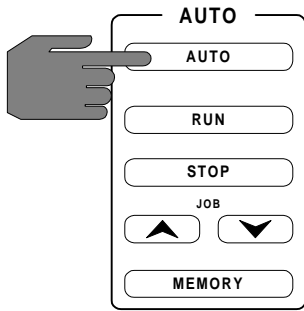

f) Press **RUN** under **AUTO**. The rollers begin turning.

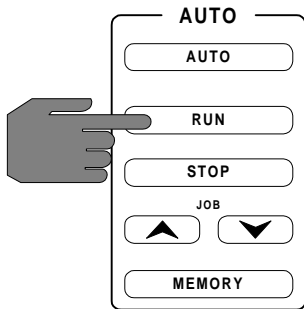

g) Pull the safety pin on the front safety shield toward the center of the machine. The rollers stop turning.

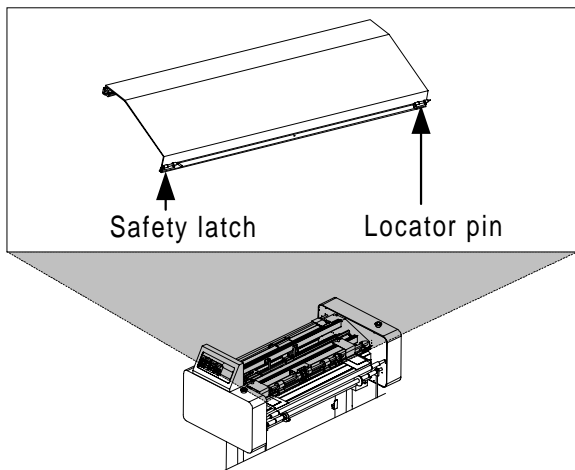

INFORMATION

Only the safety latch (on the left) will stop the machine. The locator pin (on the right) is to secure the right side of the safety shield.



DANGER

At no time should you attempt to over ride any of the safety devices on the cutter.

h) Slide the safety pin back into the interlock switch.

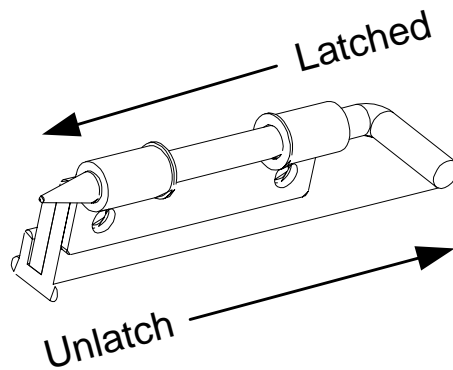

INFORMATION

The machine will only operate with the safety shield in the fully closed position.

Emergency stops

a) Press **AUTO** on the control panel.

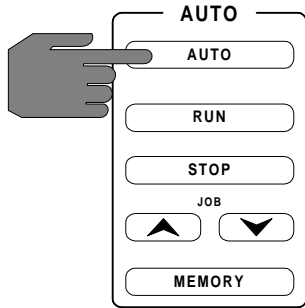

d) Rotate the **E-STOP** clockwise to reset.

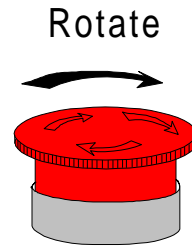

b) Press **RUN** under **AUTO**. The rollers begin turning.

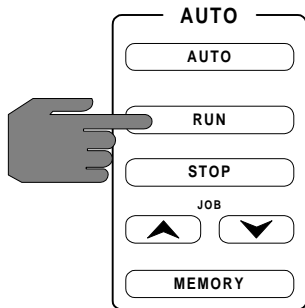

e) Press **AUTO** on the control panel.

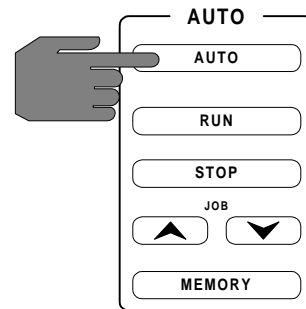

c) Press down on the right side **EMERGENCY STOP (E-STOP)**. The rollers stop turning.

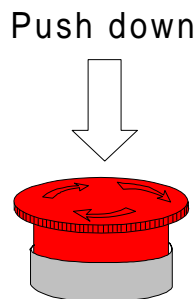

f) Press **RUN** under **AUTO**. The rollers begin turning.

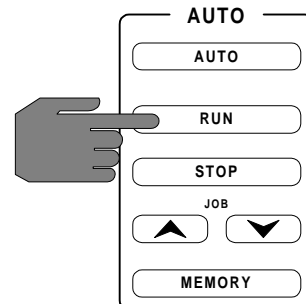

- d) Press down on the left side **E-STOP**. The rollers stop turning.

Push down

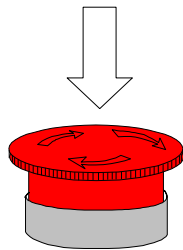

- d) Rotate the **E-STOP** clockwise to reset.

Rotate

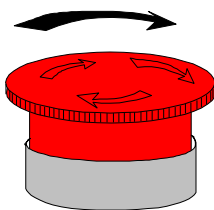

INFORMATION

The machine will only operate with both E-STOPS in the up position and the safety shield in the fully closed position.

4.9 Control panel check

The control panel should be checked to ensure all controls function properly. When checking, ensure the control panel display reflects the input accordingly.

For a detailed explanation of the control panel inputs, refer to **Section 5 Operations**.

When **POWER** is pressed to “**I**”, **SETUP** mode is automatically selected with default values displayed in the panel. Refer to **Figure 4.9.1 Default display**

Figure 4.9.1 Default display

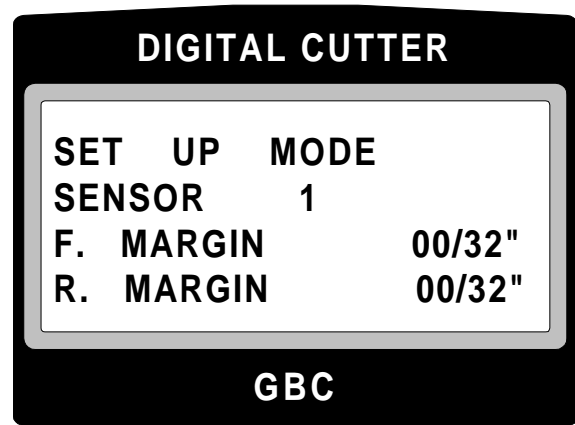

SETUP

- Display shows

a) Press **mm**.

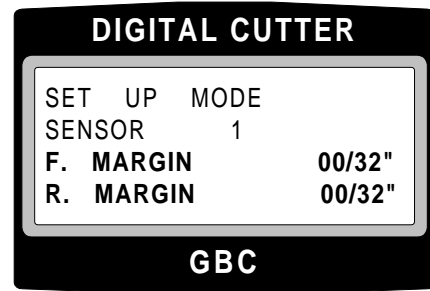
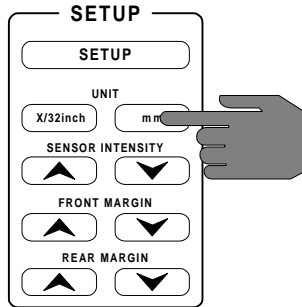

c) Press **▲** under **SENSOR INTENSITY**.
 The value for sensor increases for each press.

- Display shows

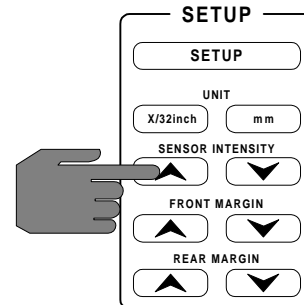
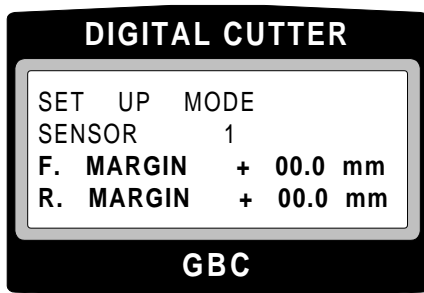

- Display shows

b) Press **X/32 inch** under **UNIT**.

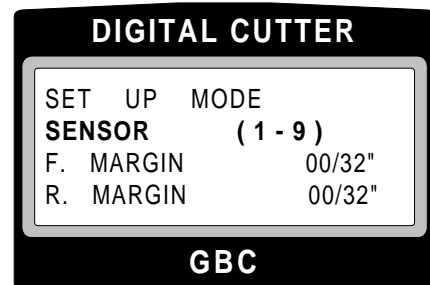
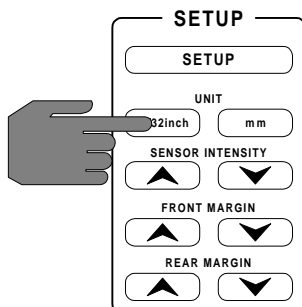

- d) Press  under **SENSOR INTENSITY**.
The value for sensor decreases for each press.

- Display shows

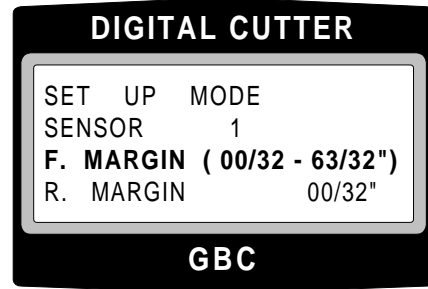
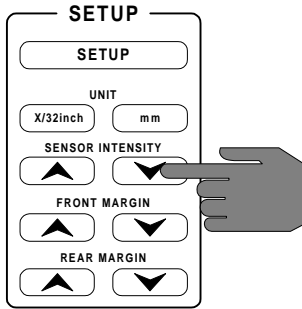

- Display shows

- f) Press  under **FRONT MARGIN**. The value for front margin decreases for each press.

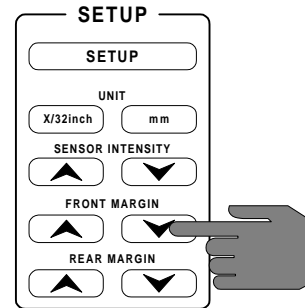
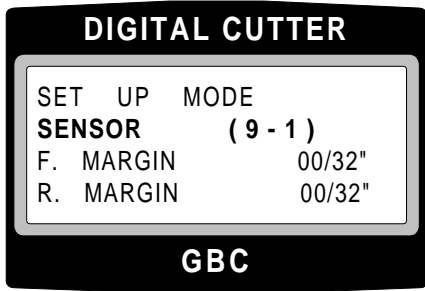

- e) Press  under **FRONT MARGIN**. The value for front margin increases for each press.

- Display shows

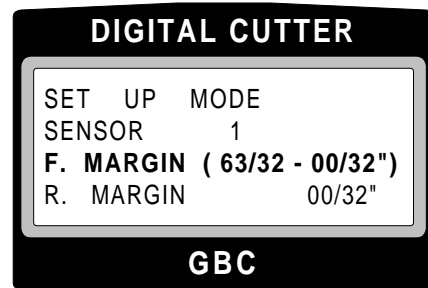
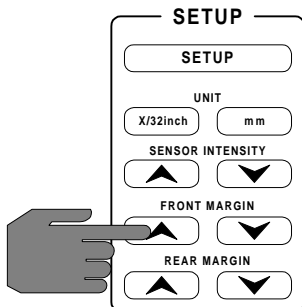

g) Press  under **REAR MARGIN**. The value for rear margin increases for each press.

- Display shows

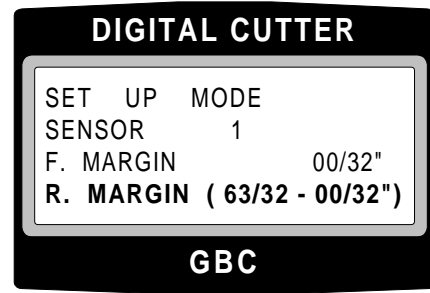
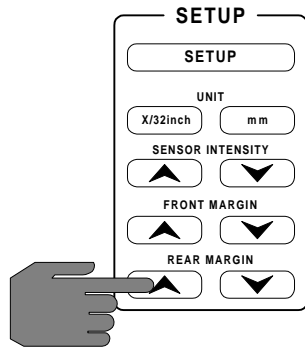

MANUAL

- Display shows

a) Press . The display switches to **MANUAL** mode

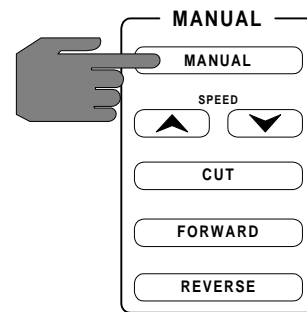
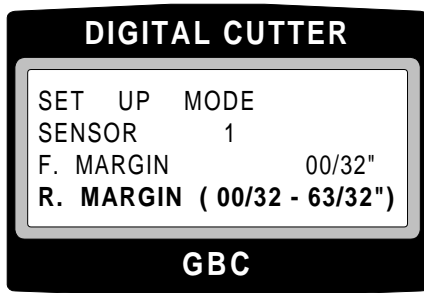

h) Press  under **REAR MARGIN**. The value for rear margin decreases for each press.

- Display shows

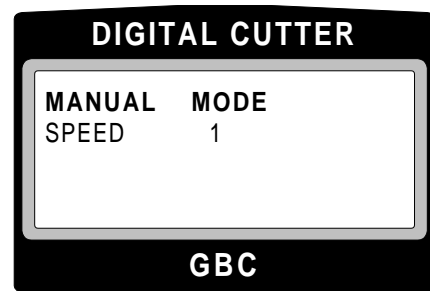
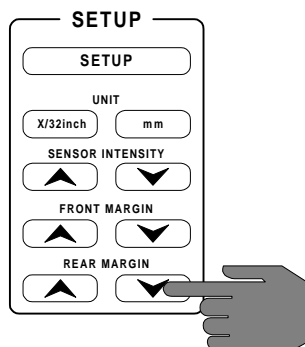

b) Press  under **SPEED**. The value for speed increases for each press.

- Display shows

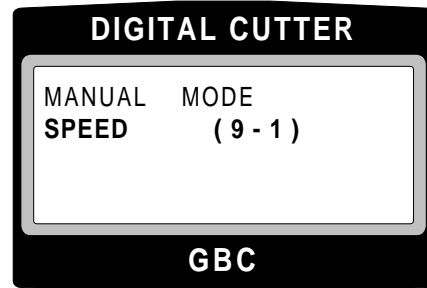
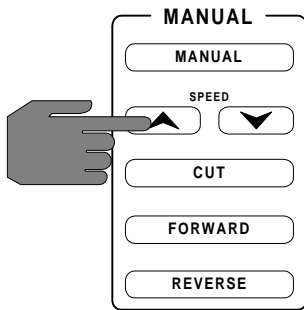

DANGER

Ensure the path of the cutting head is clear. You can be cut or damage the cutting head.

- Display shows

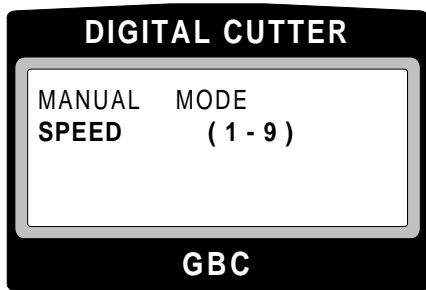

d) Press  .

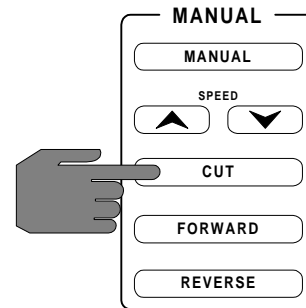

c) Press  under **SPEED**. The value for speed decreases for each press.

- The cutting head moves from one side to the other side.

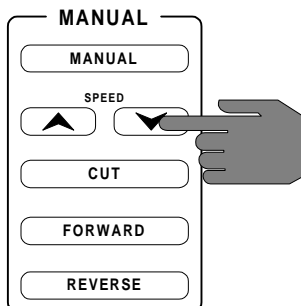

CAUTION

Do not use the Digital Cutter for any purpose other than what the machine was designed for.

e) Press **FORWARD**. The rollers turn in a forward motion for the duration of the press.

- Display shows **REVERSE** while pressed

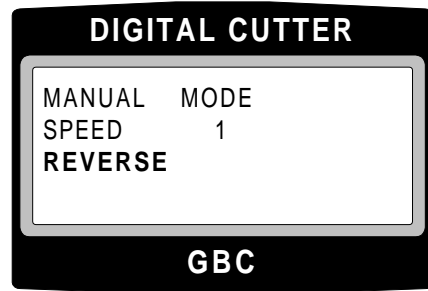
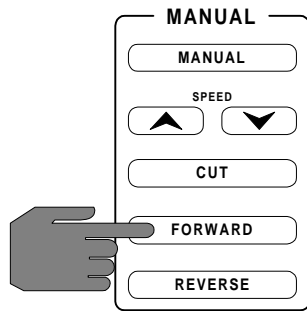

- Display shows **FORWARD** while pressed

AUTO

a) Press **AUTO**. The display switches to **AUTO** mode

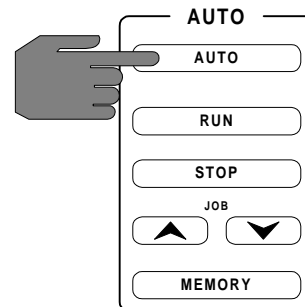
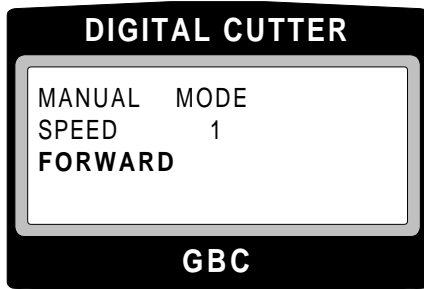

f) Press **REVERSE**. The rollers turn in a reverse motion for the duration of the press.

- Display shows

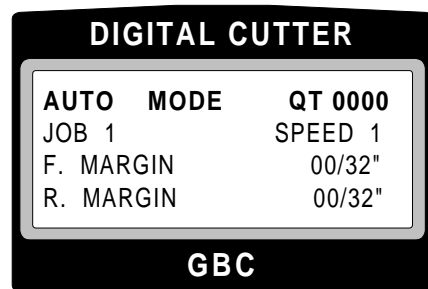
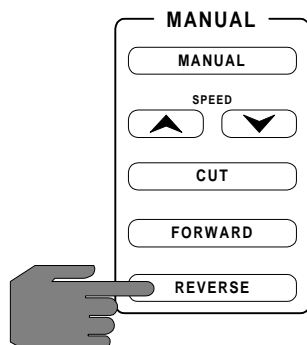

b) Press **RUN**. The rollers begin turning.

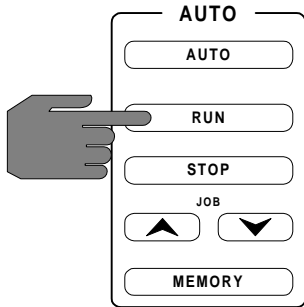

- No changes to the display panel

d) Press **▲** under **JOB**. The value for job increases for each press.

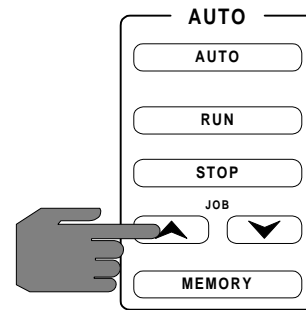

- Display shows

c) Press **STOP**. The rollers stop turning.

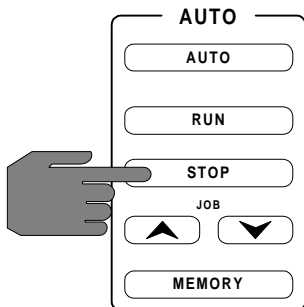

- No changes to the display panel

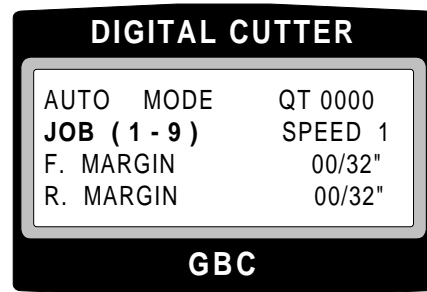

e) Press **▼** under **JOB**. The value for job decreases for each press.

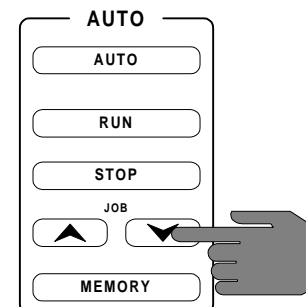

INFORMATION

The machine will only operate with the safety shield in the fully closed position.

- Display shows

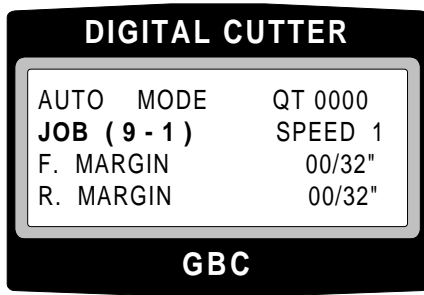

INFORMATION

When in AUTO mode, the speed can be changed using the speed controls within the MANUAL group. The display will indicate the change in values.

- Display shows

f) Press **MEMORY**.

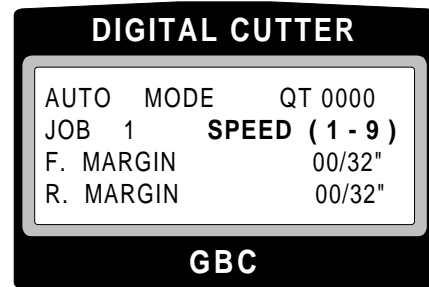
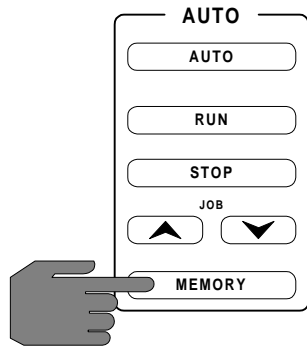

SHEETING

- **JOB** on the display panel begins flashing. Press **MEMORY** again to revert **JOB** to solid.

a) Press **SHEETING**.



INFORMATION

Storing parameters is described in Section 5.3 Job Programming.

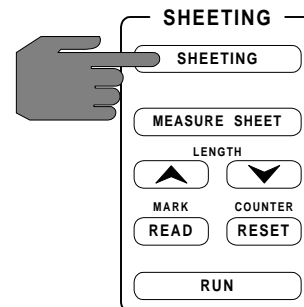

- Display shows

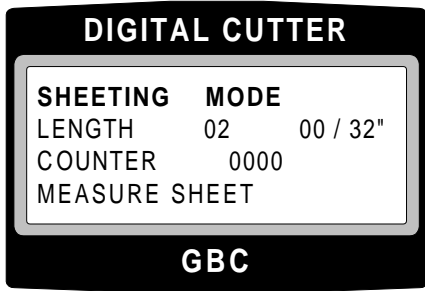

- Display shows

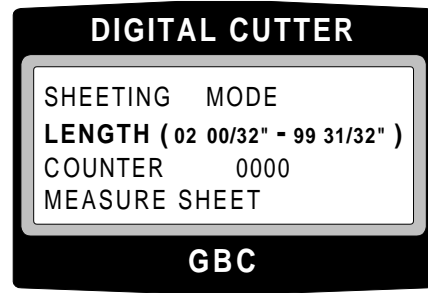

b) **MEASURE SHEET** is illuminated once **SHEETING** mode has been selected.

d) Press **▼** under **LENGTH**. The value for length decreases for each press.

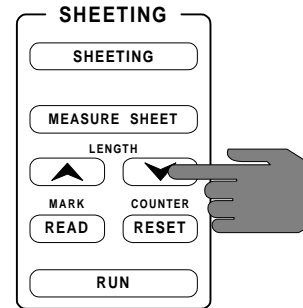
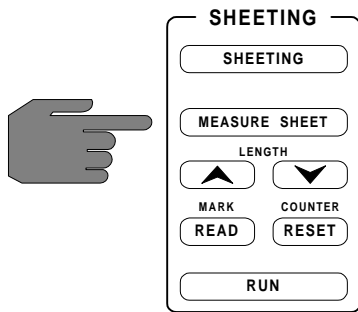

- No changes to the display panel

c) Press **▲** under **LENGTH**. The value for length increases for each press.

- Display shows

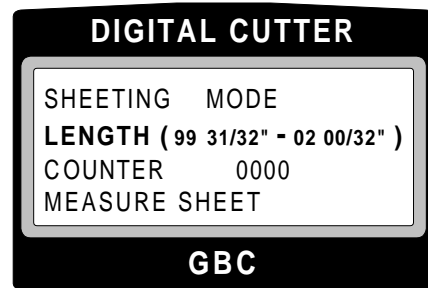
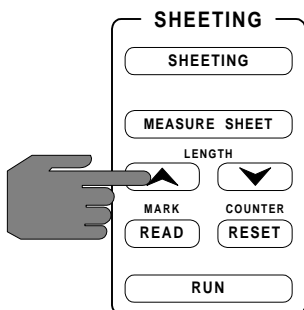

e) Press **READ** under **MARK**.

- **COUNTER** resets to **0000** if any other value is displayed.

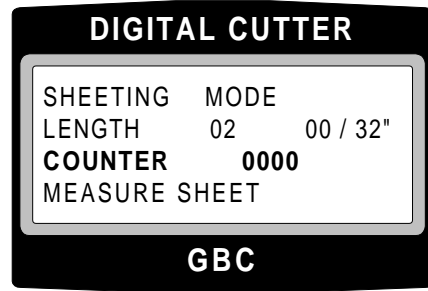
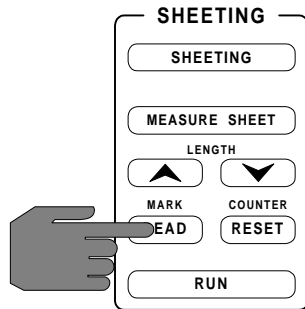

- Display shows

g) Press **RUN**. The rollers begin to turn and cuts after each input length value.

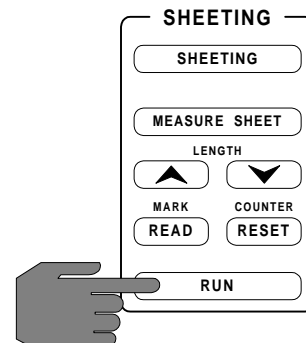
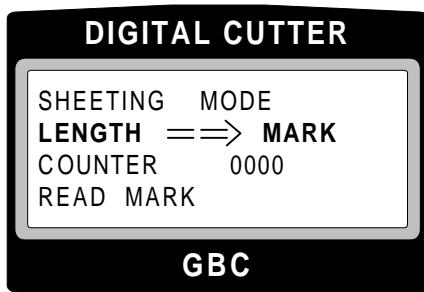

f) Press **RESET** under **COUNTER**.

- No changes to the display panel

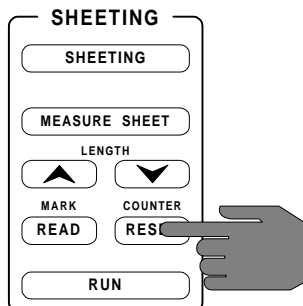

INFORMATION

Purpose and function of each mode is explained in Section 5 Operations

4.10 Installing the catcher

The catcher prevents small cut pieces from falling to the floor. No tools are required to install the catcher to the cutter. This item is optional for the operator.



INFORMATION

The catcher does not prevent the cutter from operating.

- a) Lay the catcher out at the rear of the machine. Refer to **Figure 4.10.1 Positioning the catcher**

Figure 4.10.1 Positioning the catcher

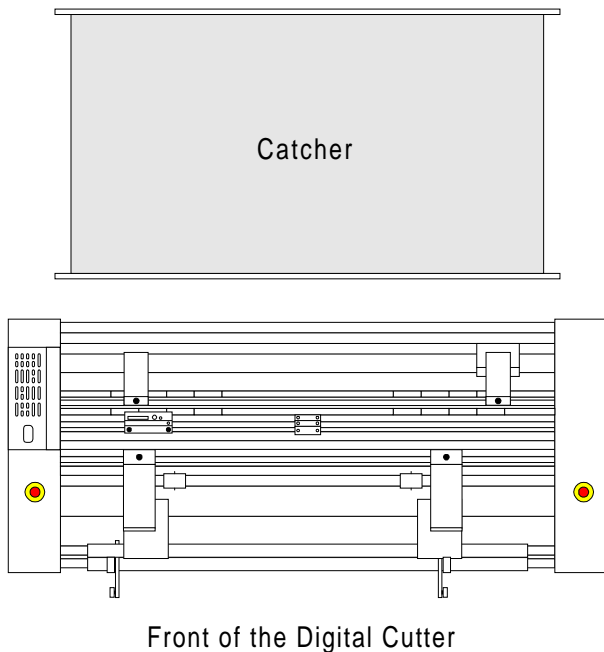

- b) Set the catcher bar closest to the cutter in the lower catcher brackets. Refer to **Figure 4.10.2 Lower catcher brackets**

Figure 4.10.2 Lower catcher brackets

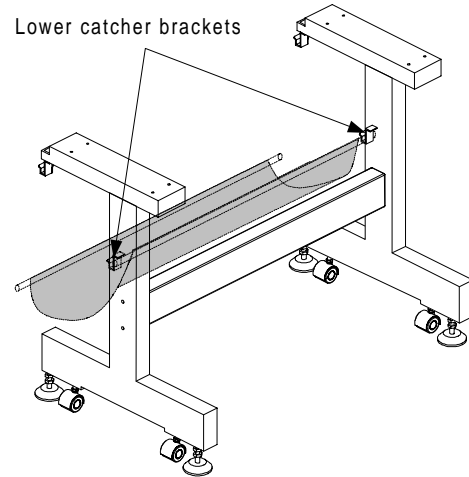

- b) Set the remaining catcher bar in the upper catcher brackets. Refer to **Figure 4.10.3 Upper catcher brackets**

Figure 4.10.3 Upper catcher brackets

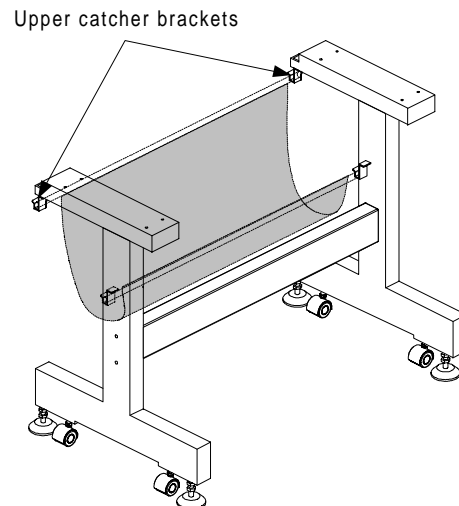

4.11 Installing the stacker

Figure 4.11.1 Positioning the stacker

Be sure to leave sufficient room around the stacker to work unrestricted. Refer to **Figure 4.1.1 Suggested floor layout**

Tools required

- 5 mm allen wrench
- 6 mm allen wrench
- Tape measure
- A second person

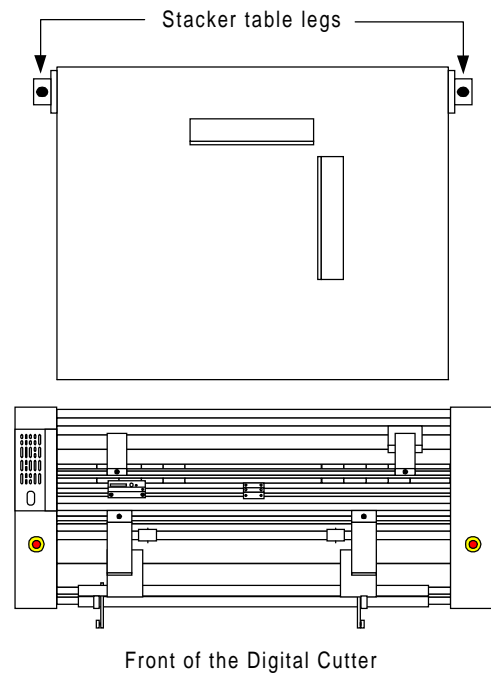

a) With help from the second person, carry the stacker table over to the cutter.

c) Lift the end closest to the cutter up and then down into the mounting brackets on the cutter. Refer to **Figure 4.11.2 Hook to mounting bracket**



WARNING

Always use safe and proper lifting practices when lifting heavy objects. You can become seriously injured or crushed.

b) Position the stacker so that the hooks are closest to the rear of the cutter. Refer to **Figure 4.11.1 Positioning the stacker**

Figure 4.11.2 Hook to mounting bracket

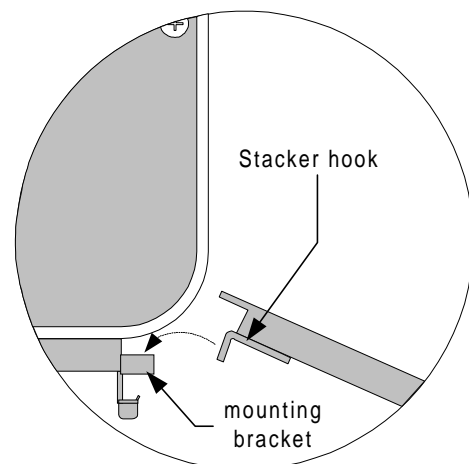

- d) Set one leg to a desired height by using the 5 mm and 6 mm allen wrenches.

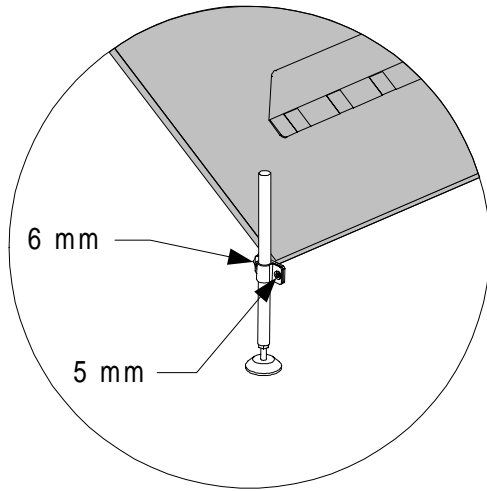
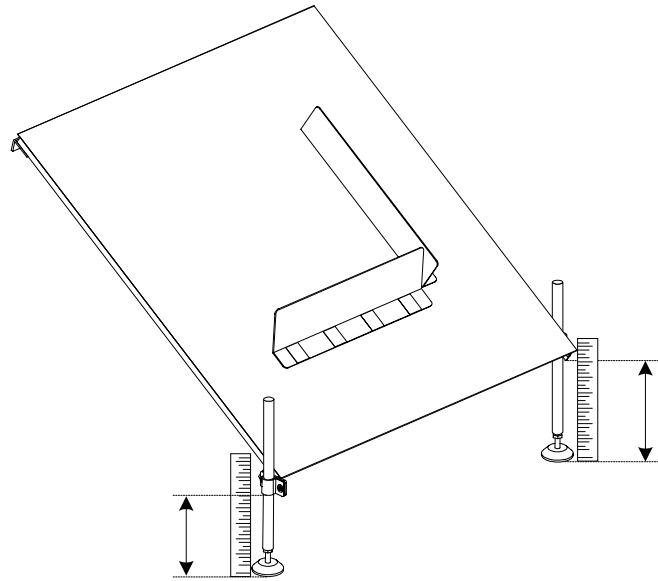
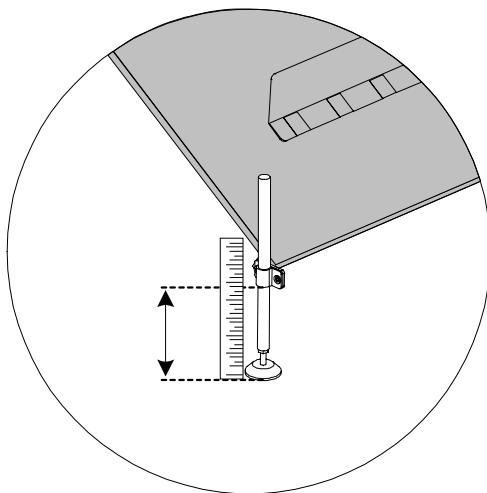

Figure 4.11.3 Leveled stacker table



- e) Measure the distance from the floor to the bottom of the stacker leg bracket.

- g) Use the 5 mm and 6 mm allen wrenches to tighten the stacker table legs securely.



INFORMATION

If the stacker table is not even from left to right, the material flow can spill off the stacker table.

- f) Set the opposite leg of the stacker to the same measurement. Refer to **Figure 4.11.3 Leveled stacker table**

- h) Position the bottom paper guide (angled) and the side paper guide (straight) on the stacker table in the manner that best fits your operating layout.

Section 5 Operations

Figure 5.1.1 Control panel



WARNING

Do not wear ties, loose fit clothing or dangling jewelry while operating or servicing the cutter. These items can get caught in the machine and choke you or you can be cut or crushed.

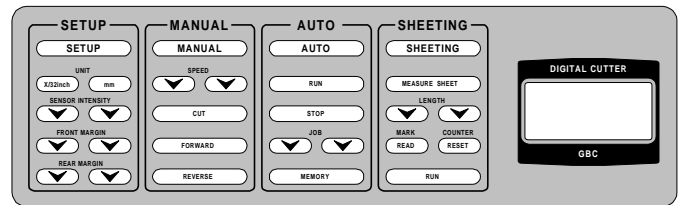

This section discusses Control panel, Emergency and Job programming.

When **POWER** is pressed to “I”, **SETUP** mode is automatically selected with default values displayed in the panel. Refer to **Figure 5.1.2 Default display**

5.1 Control Panel

Figure 5.1.2 Default display

The control panel for the Digital Cutter is located on the left side from the front of the machine. Refer to **Figure 5.1.1 Control panel**

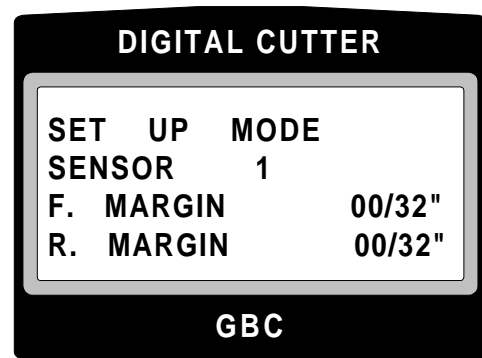

The control panel is separated into four modes. The control display shows information for the mode selected by the operator.

Once a desired mode has been selected, various settings can be changed within the group for that particular mode.



INFORMATION

The control panel is explained in four modes. (**SETUP**, **MANUAL**, **AUTO** and **SHEETING**)

Unit of measurement will always be inches until mm is selected.

SETUP

(3) UNIT **mm** : When pressed, switches the unit of measurement from inches to mm.

Within the **SETUP** mode, the operator may adjust unit, sensor intensity, front margin and rear margin.

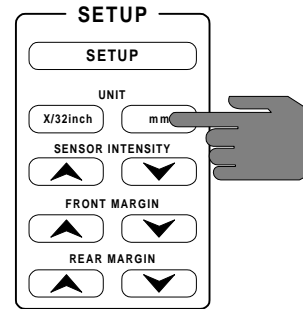

(1) **SETUP** : When pressed, selects the setup mode for the control panel.

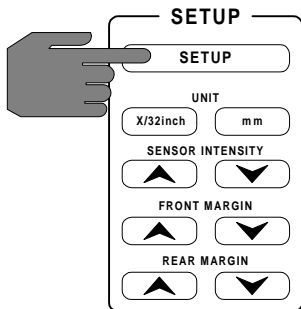

INFORMATION

With respect to unit of measurement, Length **▲** in SHEETING mode will give 1/32 inch increments by pressing it twice or sometimes once. This is due to the the microprocessor taking the decimal into consideration during the calculation process.

(2) UNIT **X/32 inch** : When pressed, reverts the unit of measurement to inches from mm.

(4) **SENSOR INTENSITY ▲** : When pressed, increases the infrared radiation sensor which detects the leading and trailing edge of the sheet. Sensor intensity has a maximum setting of 9.

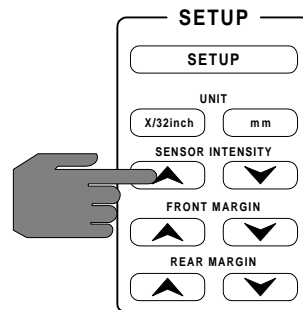
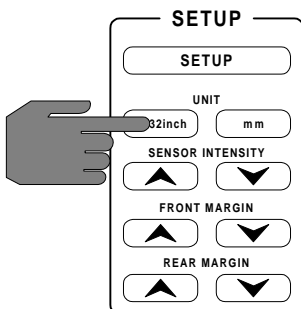

(5) **SENSOR INTENSITY** (▼): When pressed, decreases the infrared radiation sensor which detects the leading and trailing edge of the sheet. Sensor intensity has a range of 1 - 9.

(7) **FRONT MARGIN** (▼): When pressed, decreases the front margin (border) of laminate before the product. This setting has a range from -63/ 32" - +63/ 32" (mm: -50 mm - +50 mm)

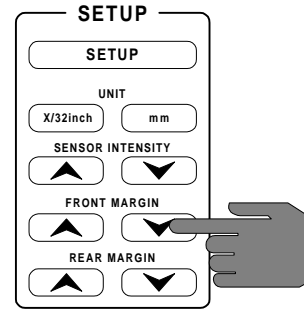
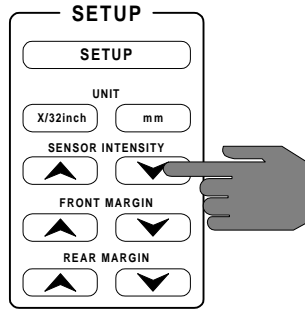

INFORMATION

When a negative value is set for the front and rear margins, the blade will cut into the product.



INFORMATION

When a negative value is set for the front and rear margins, the blade will cut into the product.

(6) **FRONT MARGIN** (▲): When pressed, increases the front margin (border) of laminate before the product. This setting has a range from -63/ 32" - +63/ 32" (mm: -50 mm - +50 mm)

(8) **REAR MARGIN** (▲): When pressed, increases the rear margin (border) of laminate after the product. This setting has a range from -63/ 32" - +63/ 32" (mm: -50 mm - +50 mm)

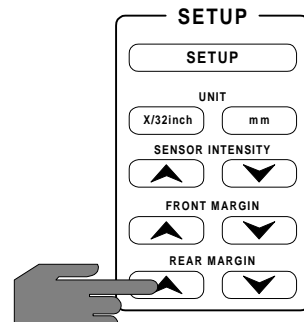
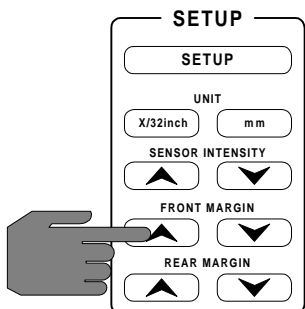

(9) **REAR MARGIN** (▼): When pressed, decreases the rear margin (border) of laminate after the product. This setting has a range from -63/ 32” - +63/ 32” (mm: -50 mm - +50 mm)

(2) **SPEED** (▲): When pressed, increases the speed of the rollers from 1 to 9.

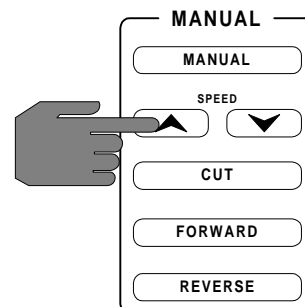
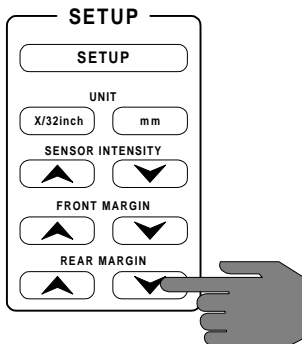

MANUAL



INFORMATION

Speed can be adjusted regardless of the mode selection.

Within the **MANUAL** mode, the operator may adjust speed, control cutting, forward drive and reverse drive.

(3) **SPEED** (▼): When pressed, decreases the speed of the rollers from 9 to 1.

(1) **MANUAL**: When pressed, selects the manual mode for the control panel.

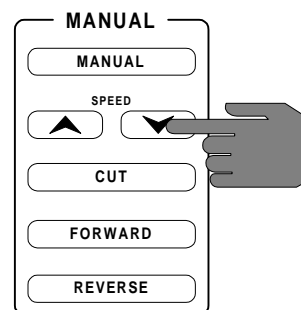
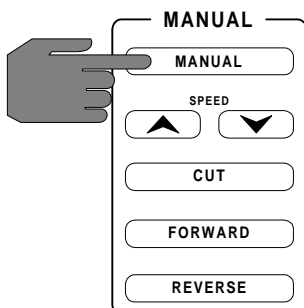



DANGER

Keep hands and fingers out from the path of the rotary cutting head when using **CUT** under **MANUAL** mode.

(4) **CUT**: When pressed, engages the rotary cutting head to move from one side to the other side. This feature is helpful in setting the width of the rotary cutting head or to manually trim the paper.

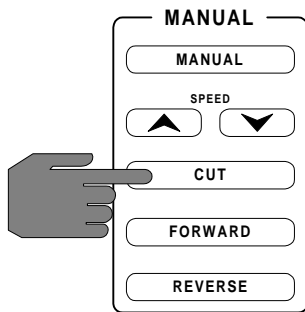

(5) **FORWARD**: When pressed, engages the rollers in a forward direction. This feature is helpful when inserting the film or removing it. When released, the rollers stop turning.

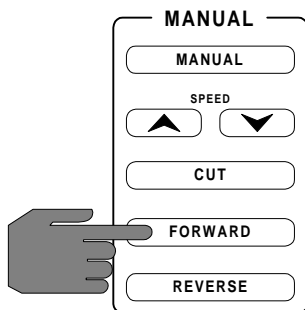

(6) **REVERSE**: When pressed, engages the rollers in a reverse direction. This feature is helpful when inserting the film or removing it. When released, the rollers stop turning.

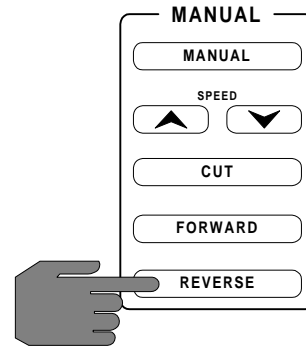

AUTO mode

Within the **AUTO** mode, the operator may control run, stop, select a job number and program job memory.

(1) **AUTO**: When pressed, selects the auto mode for the control panel.

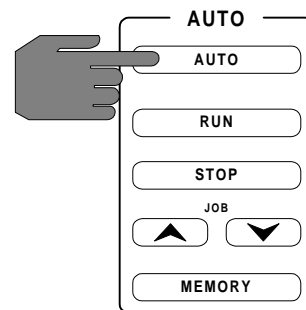

(2) **RUN** : When pressed, the cutter operates within the confinement of the set parameters selected in **SETUP** mode. The cutter will operate until **STOP** is pressed.

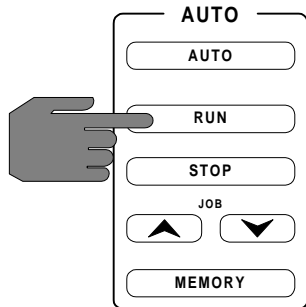

(4) **JOB** (▲) : When pressed, increases the job selection of the cutter from 1 to 9.

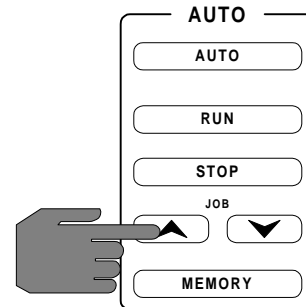

INFORMATION

The machine will only operate with both E-STOPS in the up position and the safety shield in the fully closed position.



INFORMATION

JOB (▲) and **JOB** (▼) are also used in conjunction with the **MEMORY**

(3) **STOP** : When pressed, stops the cutter's movement under **AUTO** mode.

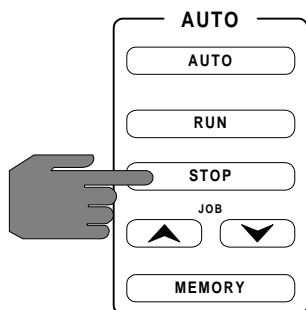

(5) **JOB** (▼) : When pressed, decreases the job selection of the cutter from 9 to 1.

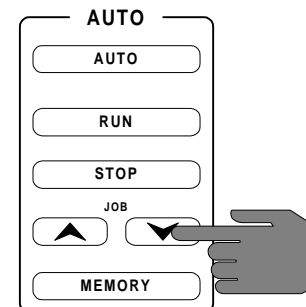

(6) **MEMORY**: When pressed once, allows for job number selection. When pressed again, retains the current settings within the selected job number.

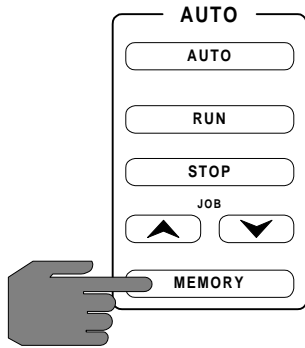

(2) **MEASURE SHEET**: When pressed, sets the operational function of the cutter to a preset size. This operational function requires an input from the **LENGTH** and **RUN** pressed under **SHEETING**.

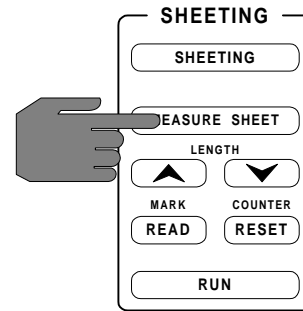

SHEETING

Within the **SHEETING** mode, the operator may measure a sheet, adjust for length, read mark, reset the counter and run the cutter.

(1) **SHEETING**: When pressed, selects the sheeting mode for the control panel.

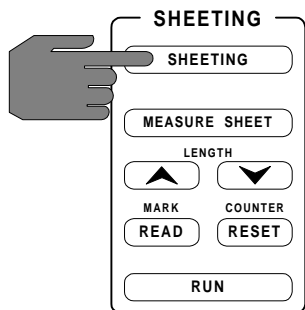

INFORMATION

This operational function has no regards to sheet size or paper to paper sensors.

(3) **LENGTH** (▲): When pressed, increases the length on the **MEASURE SHEET** function. Length has a range of 00-1/ 32" - 99-31/ 32" (mm: 50 - 2539 mm)

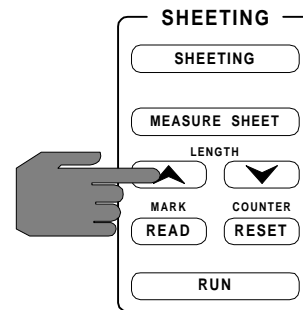

(4) **LENGTH** : When pressed, decreases the length on the **MEASURE SHEET** function. Length has a range of 00-1/ 32” - 99-31/ 32” (mm: 50 - 2539 mm)

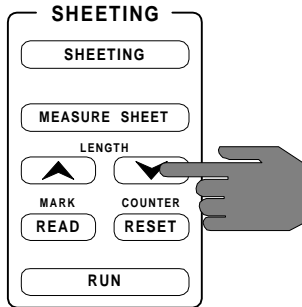

(6) **COUNTER** : When pressed, reverts the counter to 0000. The counters range is 0000 to 9999.

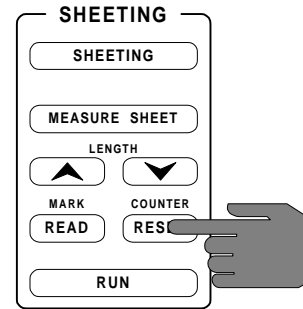

(5) **MARK** : When pressed, sets the operational function of the cutter to detect the image line crop mark indicating the cutting location on the paper.

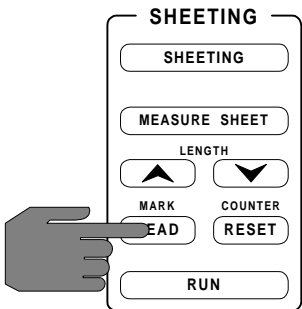

INFORMATION

The counter only counts sheets when operating in **AUTO** mode and **SHEETING** mode.

(7) : When pressed once, the cutter operates under the set operational function selected under **SHEETING** mode. Press again to stop.



INFORMATION

This operational function requires that you follow the procedure outlined in Section 6.5 Crop Mark function.

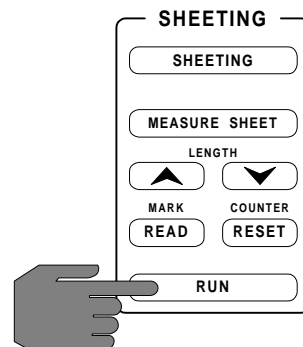

5.2 Emergency

Reacting to an emergency situation

The Digital Cutter has been designed with safety as a primary consideration; however, you must become thoroughly familiar with the controls, proper operation, proper service procedures, and safety features of the machine before using or servicing.

- a) In the event of an emergency, press an **E-STOP**.



INFORMATION

The machine will only operate with both E-STOPS in the up position and the safety shield in the fully closed position.



INFORMATION

When an EMERGENCY STOP is engaged, all motion stops.

- b) Resolve the emergency situation.

Know where the two emergency stops (**E-STOP**) are located before operating the laminator. Refer to **Figure 5.2.1 E-STOPS**



INFORMATION

If the cutter is inline with a laminator, be sure to stop the laminator when possible.

Figure 5.2.1 E-STOPS

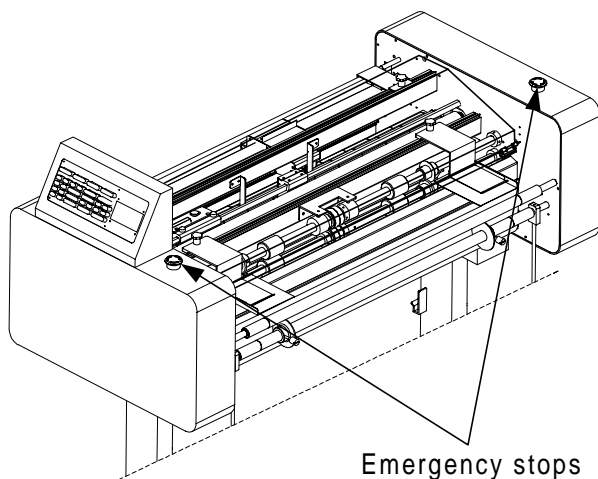

- c) If the front safety shield was lifted, ensure that it is in the fully locked position.



INFORMATION

Power to the motor is removed when the safety shield is not in the fully locked position.

- d) Reset the **E-STOP** by rotating 1/4 turn clockwise. The **E-STOP** will unlatch.

5.3 Job programming

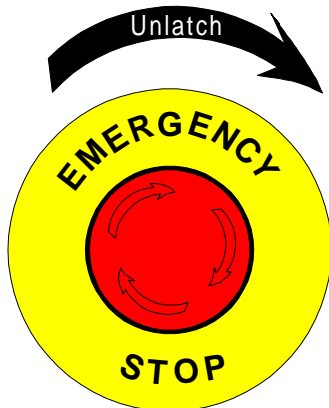

The job memory feature is very convenient if the same parameters are required to perform various trimmings. This procedure will guide you step by step through this feature.



INFORMATION

Follow the suggested starting procedure for the laminator after an emergency situation.



INFORMATION

FRONT MARGIN, REAR MARGIN, SENSOR INTENSITY, UNIT, SPEED and LENGTH are parameters that can be stored.

- e) Resume running.

- a) Enter the desired values in the control panel for the appropriate settings.

- b) Press to select **AUTO** mode.



INFORMATION

Engaging an **E-STOP** does not affect any of the parameters on the control panel.

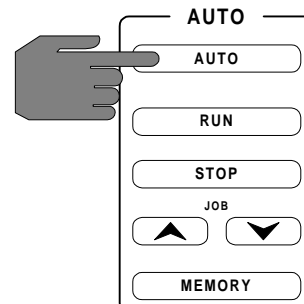

- The display shows;

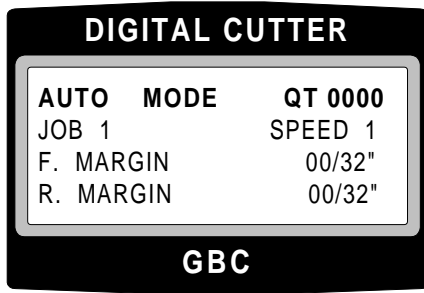

c) Press **JOB** or **JOB** to select the desired storage location.

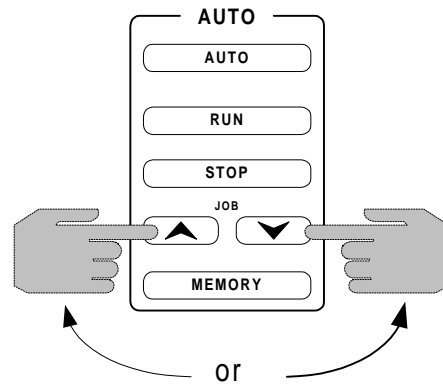

INFORMATION

Values will reflect your desired settings.

- **JOB** number shows your selected location.

b) Press .

d) Press .

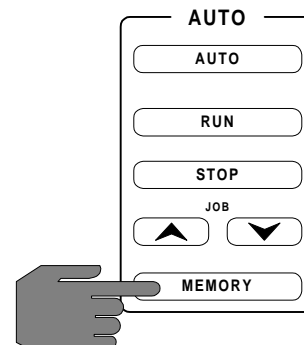
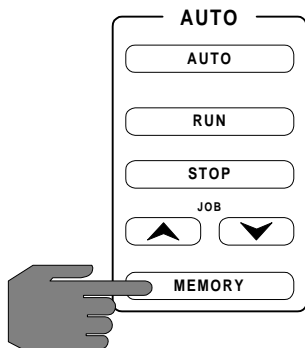

- **JOB** number will be flashing.

- Parameters have been stored in the displayed **JOB** number.

This page intentionally left blank.

Section 6 Applications

6.1 Webbing

The Digital Cutter can be operated in one of four operational functions.

- **Setup**
 - **Manual**

- **Operational**
 - **Sheeting**
 - **Web**
 - **Crop Mark detection**

Follow the procedure that best fits your operation.

Webbing will be performed in the same manner for each of the four operational functions. Webbing consists of three parts, setting the left/ right trimmers, Feeding the web and operational function selection.



WARNING

Caution should always be exercised when using the Digital Cutter with the safety shield in the raised position. You can be seriously hurt or injured!



WARNING

Do not wear ties, loose fit clothing or dangling jewelry while operating or servicing the cutter. These items can get caught in the machine and choke you or you can be cut or crushed.



INFORMATION

The machine will only operate with both E-STOPS in the up position and the safety shield in the fully closed position.

Setting the left / right trimmers

- a) Measure the width of the web material. Then raise the front safety shield.

- b) Set the feed guides so that the web runs through the center of the cutter and secure in place.

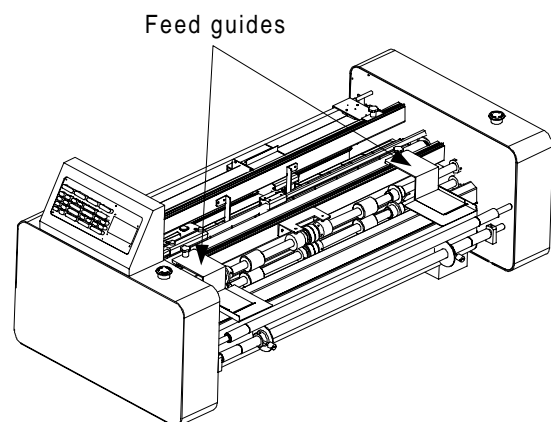

**WARNING**

Exercise extreme caution when adjusting the left / right trimmers. Sharp blades can cut you!

- c) With a 3 mm allen wrench, adjust the left and right trimmers to cut along the desired point and secure in place.

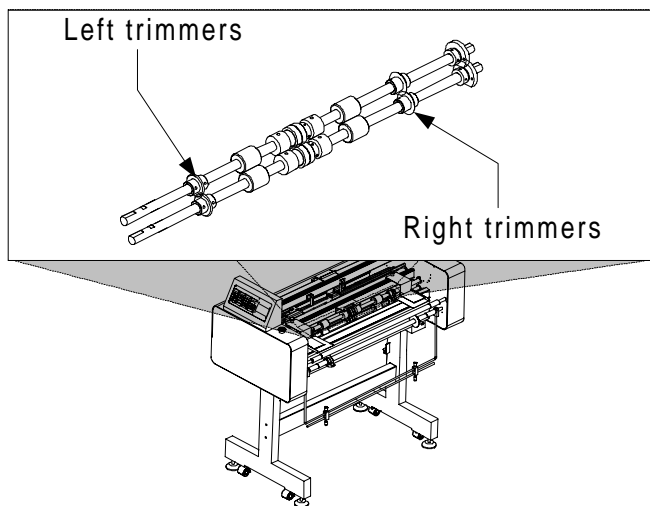
**INFORMATION**

Set the lower trimmers first. Then set the upper trimmers firmly against the lower trimmers.

- d) If the left/ right trimmers are not required, slide the left trimmers to the far left and slide the right trimmers to the far right.

Feeding the web

- a) Slide the left first idler guide and left bailer bar guide to the left far enough to feed the web. Refer to **Figure 6.1.1 Left Guides**

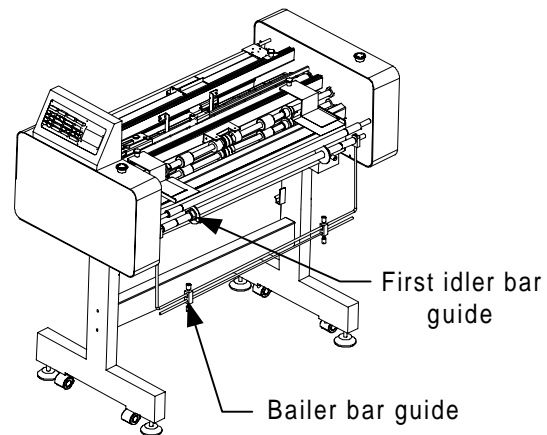
Figure 6.1.1 Left Guides

- b) Slide the right first idler guide and the right bailer bar guide to the right far enough to feed the web. Refer to **Figure 6.1.2 Right guides**

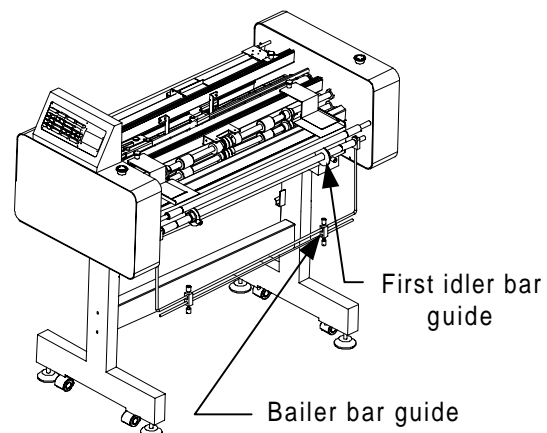
Figure 6.1.2 Right Guides

c) Feed the web through the bailer bar.

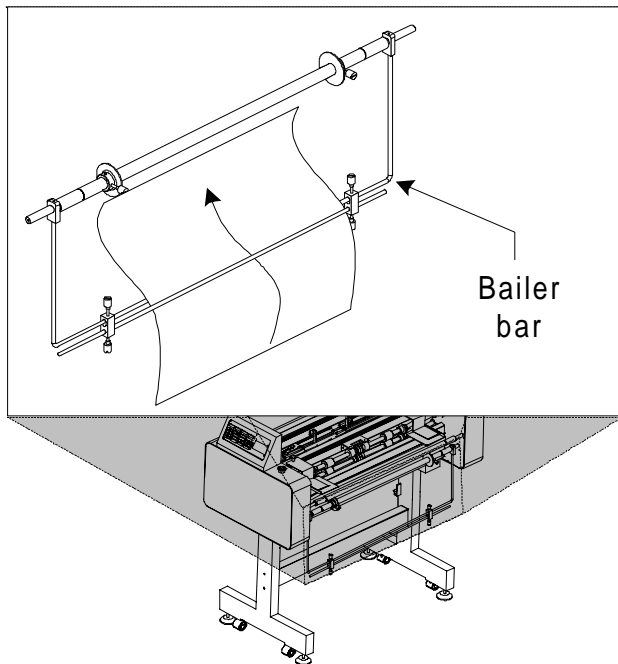

e) From the second idler, feed the web into the feed guides.

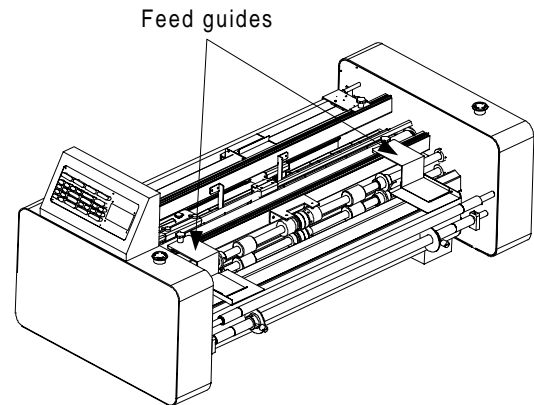

c) From the bailer bar, bring the web behind the first idler.

d) From the first idler, bring the web in front of the second idler.

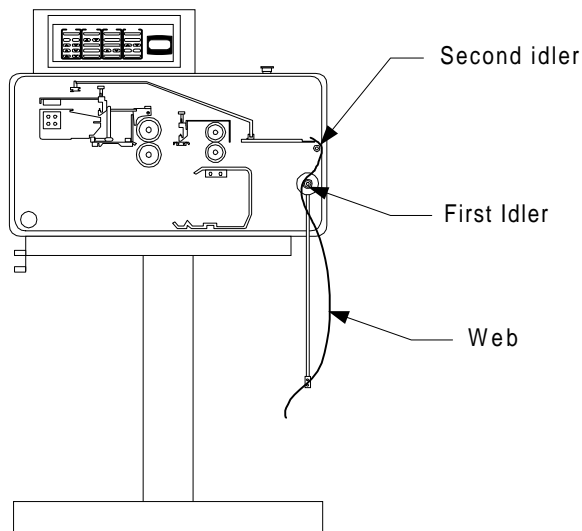

f) While manually turning the rollers slowly with one hand, use the other hand to push the web into the left/ right trimmers and into the rollers.



CAUTION

Ensure that the trimmed web is guided down to the catcher. If not, the trimmed web may wrap around the rollers and cause problems with the operation.

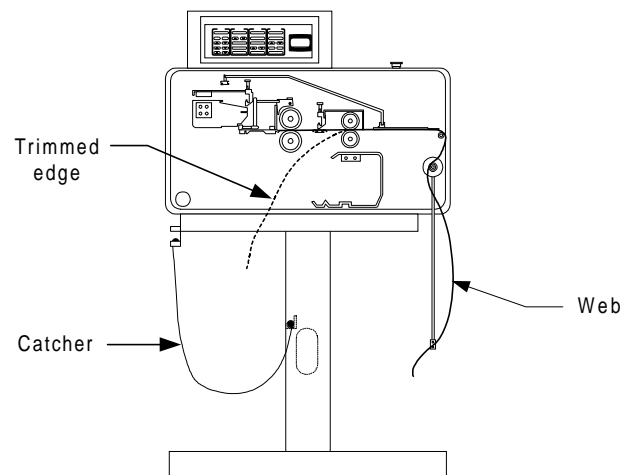

g) Stop when the web has just passed the rollers.

h) Adjust the left and right guides to the first idler and bailer bar so the web just slide between them.

i) Adjust the left and right rotary cutting head sensors close to the edges of the web but not over the web.

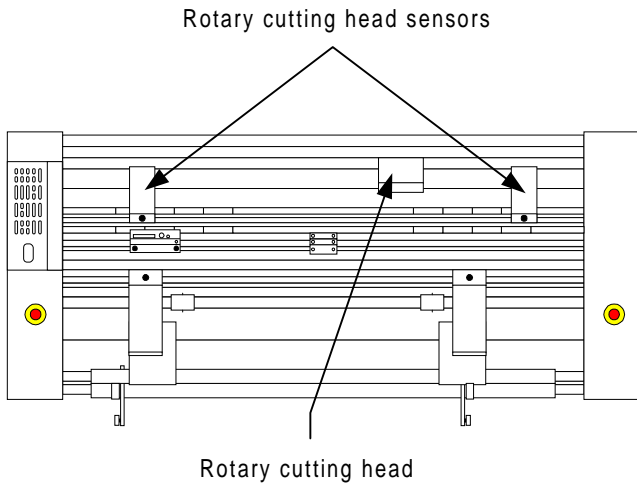

INFORMATION

The rotary cutting head sensors confine the left and right movement of the rotary cutting head unit.

j) Close the front safety shield.

6.2 Manual

Manual function allows the operator to control when the web moves forward or reverse and when the rotary cutting head travels from one side to the other side.



INFORMATION

The machine will only operate with both E-STOPS in the up position and the safety shield in the fully closed position.

a) Once the webbing has been completed, turn power to “ I ” .

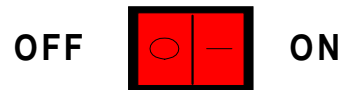

b) Press on the control panel.

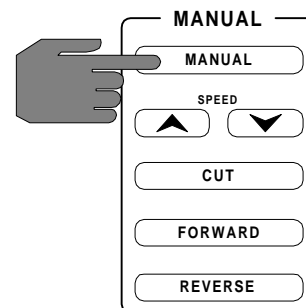

c) Press  or  under **MANUAL:** **SPEED** to enter a desired speed.

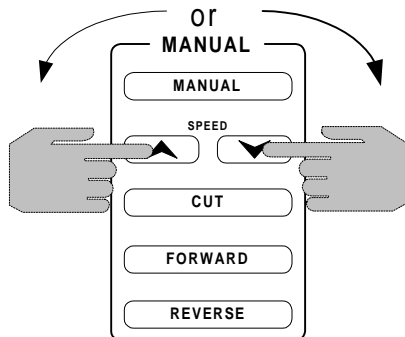

INFORMATION

Speed may be changed at anytime regardless of **MODE** selection.

f) Release  when you have come to the desired cutting point.



INFORMATION

Use  if you should pass your desired cutting point.



DANGER

Ensure the path of the cutting head is clear. You can be cut or damage the cutting head.

d) Position the two paper guides on the stacker as necessary.

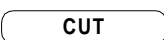
g) Press  to engage the rotary cutting head.

e) Press  under **MANUAL**.

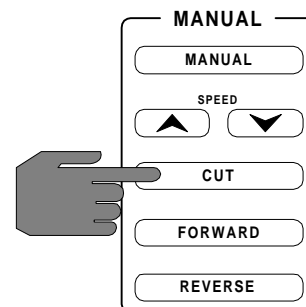
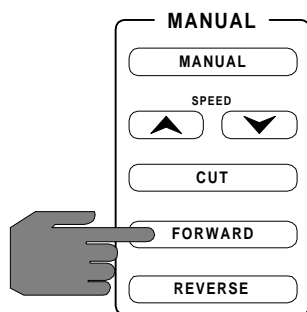

h) Repeat steps e), f) and g) as necessary.

6.3 Sheeting

Sheeting function allows the operator to control the length at which the cutter will cut. Sheeting function is used when you require a quantity of specified sheet lengths.



INFORMATION

The machine will only operate with both E-STOPS in the up position and the safety shield in the fully closed position.

c) Press or under **SHEETING** to enter a sheet length.

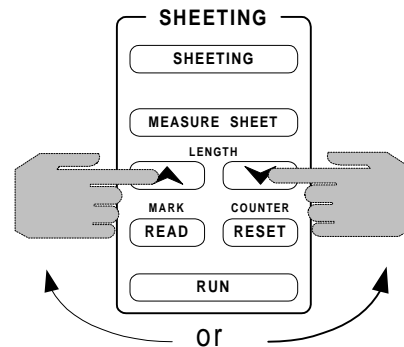

d) Press or under **MANUAL: SPEED** to enter a desired speed.

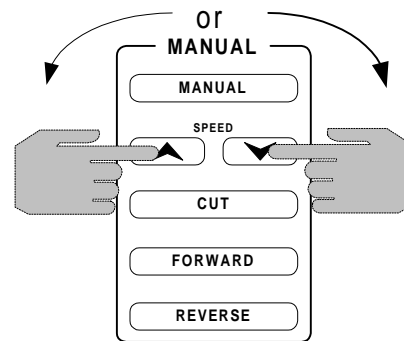

a) Once the webbing has been completed, turn power to "I".

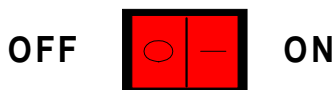

b) Press on the control panel.

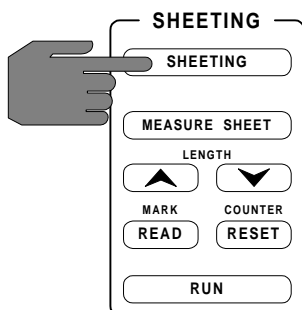

INFORMATION

Speed may be changed at anytime regardless of MODE selection.



DANGER

Ensure the path of the cutting head is clear. You can be cut or damage the cutting head.

6.4 Web

Web function sets the cutter to automatically detect the sheets in the web and cuts before and after. The operator may change the margins of the front cut and the rear cut.

e) Position the two paper guides on the stacker as necessary.

f) Press under **SHEETING** to engage the cutter.

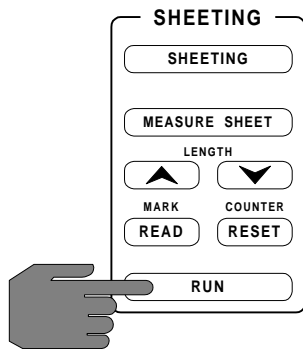

g) Press again under **SHEETING** to stop the cutter.



INFORMATION

The machine will only operate with both E-STOPS in the up position and the safety shield in the fully closed position.

a) Once the webbing has been completed, turn power to “I”.

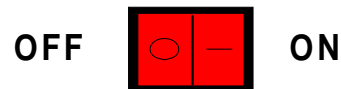

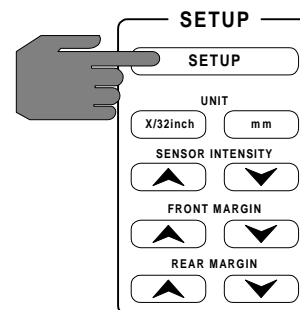

b) Press on the control panel.

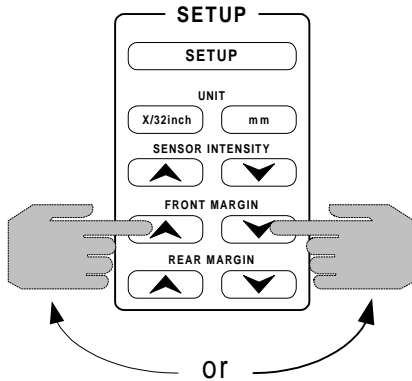

c) Press  or  under **SETUP:**
FRONT MARGIN to enter a front margin.



e) Press  or  under **SETUP:**
SENSOR INTENSITY to enter a desired detection sensor.

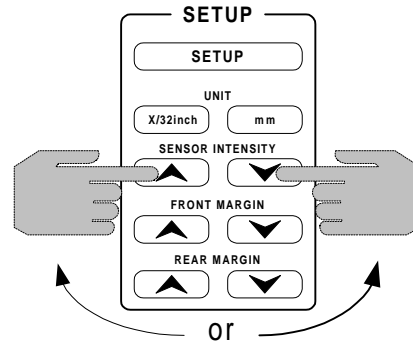

d) Press  or  under **SETUP:**
REAR MARGIN to enter a rear margin.

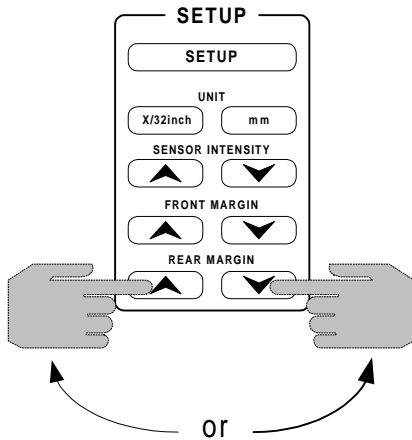

INFORMATION

Approximately 3 or 4 should be used for Matte film and 1 or 2 for transparent film.

f) Press  or  under **MANUAL:**
SPEED to enter a desired speed.

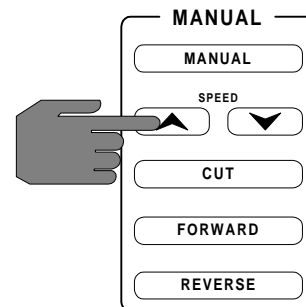

INFORMATION

When a negative value is set for the front and rear margins, the blade will cut into the paper.



INFORMATION

Speed may be changed at anytime regardless of MODE selection.

g) Press **AUTO** on the control panel.

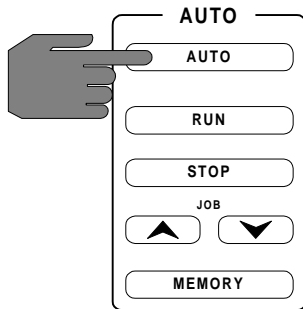

DANGER

Ensure the path of the cutting head is clear. You can be cut or damage the cutting head.

6.5 Crop mark detection

Crop mark detection function sets the cutter to automatically detect and cut at the crop marks on the sheets in the web.



INFORMATION

The machine will only operate with both E-STOPS in the up position and the safety shield in the fully closed position.

a) Once the webbing has been completed, turn power to "I".

h) Press **RUN** under **AUTO** to engage the cutter.

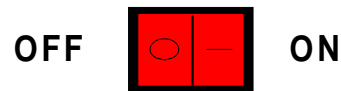
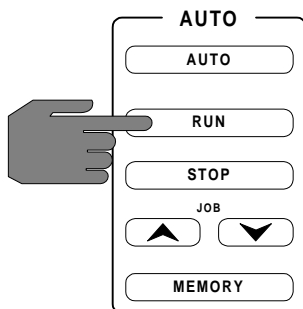

b) Press **SHEETING** on the control panel.

h) Press **STOP** under **AUTO** to stop the cutter.

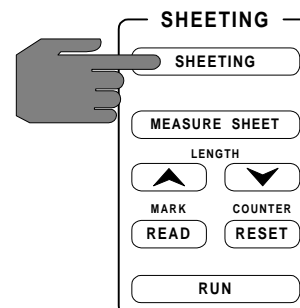



WARNING

Caution should always be exercised when using the Digital Cutter with the safety shield in the raised position. You can be seriously crushed or injured!

e) Set the **RUN/SIF/SEL** switch to **SEL** on the crop mark reader.

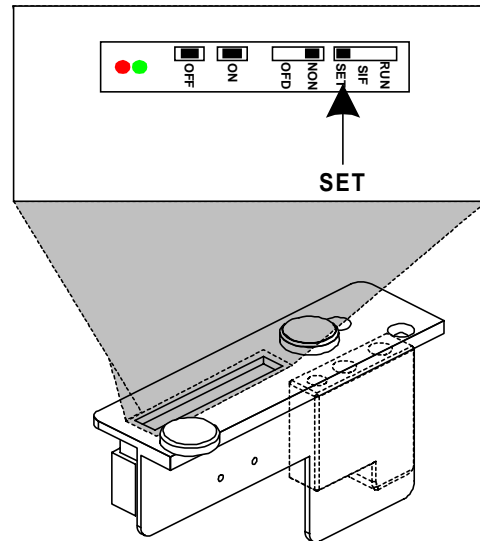

c) Raise the front safety shield.

d) Manually turn the rollers to align the crop mark on the sheet with the center of the eye on the crop mark reader.

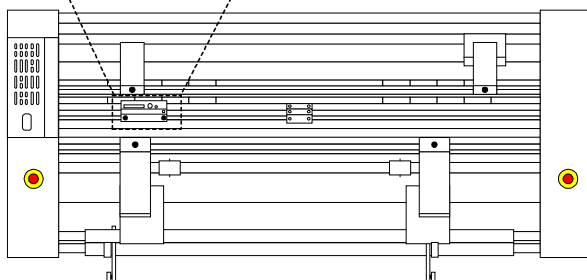
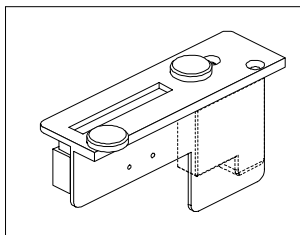

f) Press **ON** on the crop mark reader unit.

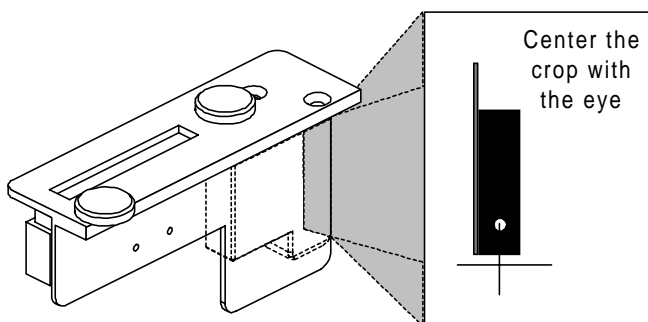
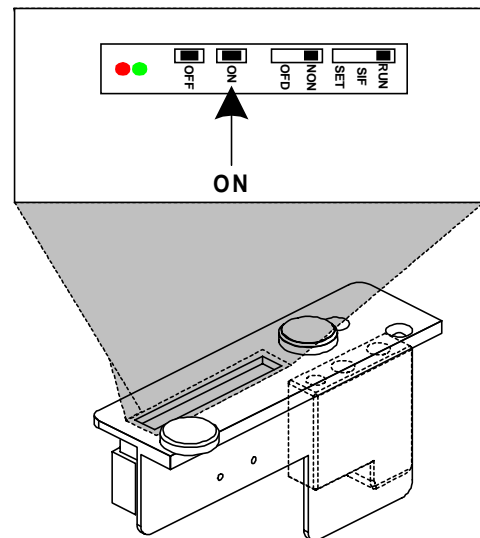

g) The red and green lights will flash. Once they stop flashing, move the crop mark on the sheet away from the crop mark reader sensor.

h) Press **OFF** on the crop mark reader unit.

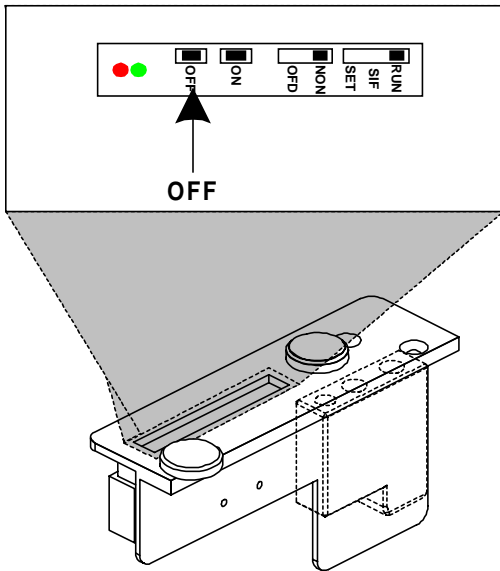

k) Press **SHEETING** on the control panel.

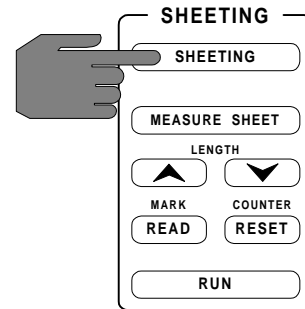

i) Set the **RUN/SIF/SEL** switch to **RUN** on the crop mark reader unit.

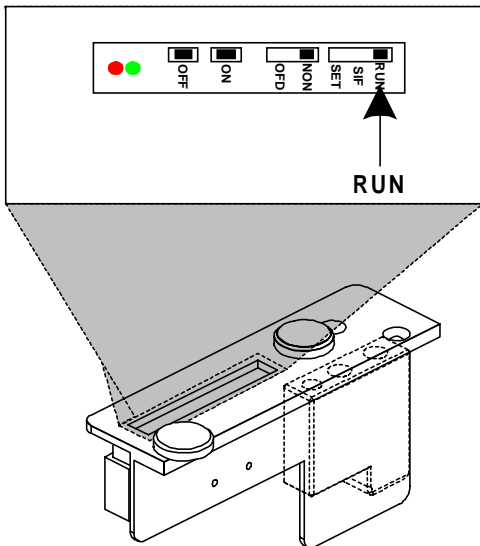

l) Press **READ** under **SHEETING: MARK**.

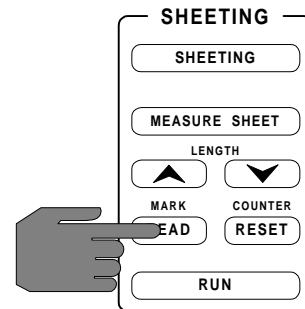

m) Press **RUN** under **SHEETING** to engage the cutter.

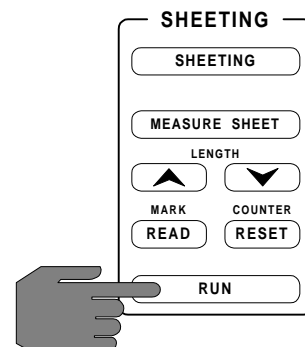

j) Close the front safety shield.

n) Press again to stop the cutter.

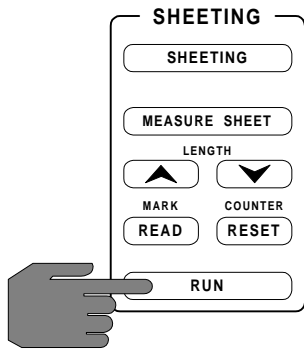

Section 7 Troubleshooting

7.1 Troubleshooting Guide



WARNING

Do not wear ties, loose fitting clothes or dangling jewelry while operating or servicing the cutter. These items can get caught in the nip and choke you or you can be crushed or burned.

As an operator, you can perform simple troubleshooting to correct typical output problems.



DANGER

At no time should you attempt to perform any repairs requiring the removal of the cabinet covers!



DANGER

At no time should you attempt to over ride the safety latch on the machine.

The chart on page 7-2 will assist you with minor repairs to the cutter. Refer to **Chart 7.1.1 Troubleshooting Guide** chart

Any checks beyond the solutions listed in the Troubleshooting guide chart should be performed by a qualified service technician. Please call your local area service representative.



ELECTRICAL SHOCK

Do not remove the cabinet covers. You can be severely shocked or killed!

Chart 7.1.1 Troubleshooting guide chart

Problem	Solution
Power is not on	<ul style="list-style-type: none"> • Ensure unit is properly plugged in. • Check for blown Circuit Fuses.
Roller is not operating	<ul style="list-style-type: none"> • Ensure an E-STOP is not depressed. • Ensure the safety shield is in the fully latched position. • Check for proper operation of rotary cutting head. • Check for blown Roller Fuse.
Rotary cutting head is not operating	<ul style="list-style-type: none"> • Check for blown Cutter Fuse. • Ensure an E-STOP is not depressed. • Ensure the safety shield is in the fully latched position.
The gap is not detected and the media comes out without being trimmed in AUTO mode.	<ul style="list-style-type: none"> • Increase the sensor intensity
The media does not come out after passing through the rollers.	<ul style="list-style-type: none"> • Make certain the rotary cutting head is adjusted to the proper width.
Side trimming is not even or sharp.	<ul style="list-style-type: none"> • Left and right rotary trimmer blades must be tight against the fixed trimmer blades.
Media is not being fed squarely.	<ul style="list-style-type: none"> • Check the distance between the left and right media guides. • Check the distance between the left and right idler bar guides. • Check the distance between the left and right bailer bar guides. • Ensure the paper is being fed squarely into the laminator.

Section 8 Maintenance

8.1 Maintenance Schedule

GBC's Digital Cutter requires minimal maintenance. However, regular maintenance is essential to keep any piece of precision machinery at peak performance. A maintenance schedule and a section of procedures are included in this section.



INFORMATION

Below is a recommended maintenance schedule. Before performing any of the steps listed, read through the procedures first. Please follow the instructions pertaining to the step you are performing.



WARNING

Do not wear ties, loose fitting clothes or dangling jewelry while operating or servicing the cutter. These items can get caught in the nip and choke you or you can be crushed.



INFORMATION

Improper maintenance, can result in poor output quality.

GBC offers Cleaning kits (P/N 1711515) as well as Extended Maintenance Agreements.

The only maintenance required by the operator is to maintain clean and adhesive free nip rollers and overall cleanliness of the machine itself.

Daily

- Clean the rollers
(See cleaning in this section)
- Inspect the electrical cord for damage.
(If damaged, it should replaced or repaired immediately)

Monthly

- Check the chain tension.
(**Performed by a qualified Service Technician**)
- Inspect the area around the machine for possible hazards
(dust buildup, combustible items stored too close, etc.)

Semi-Annual

8.2 Cleaning the rollers

- Lubricate the chains and gears.
(**Performed by a qualified Service Technician**)
- Check wire termination tightness.
(**Performed by a qualified Service Technician**)



**ELECTRICAL
SHOCK**

Remove power from the machine before servicing. You can be severely shocked, killed or cause a fire.



CAUTION

Never clean the rollers with sharp or pointed objects. You may put irreparable cuts into the rollers.



CAUTION

Do NOT pick or pull heat activated adhesive off the rolls when they are cold. You can cause irreparable damage to the laminating rolls.

Tools required

- Damp cloth
(Use water only to dampen the cloth)
- Rubber cement eraser
(a belt sander dressing block may be used instead)
- Several 100% cotton terry cloths
(best for lint free cleaning)
- 3M™ Scotchbrite™ pad

a) Turn **POWER** to off “O”.

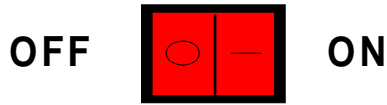

8.3 Clean the cabinets and covers



WARNING

Caution should always be exercised when using the Digital Cutter with the safety shield in the raised position. You can be seriously hurt or injured!



ELECTRICAL SHOCK

Remove power from the cutter before cleaning. You can be severely shocked, killed or cause a fire.

b) Raise the front safety shield.

a) Use a damp cotton terry cloth (water only), clean the exterior of the laminator.

c) Use the rubber cement eraser to remove any rings of adhesives from the rollers.

b) If water is not strong enough, you may use a mild dish washing detergent with water and a cotton terry cloth.

d) Use a damp cloth to wipe the beads of adhesives off of the rollers.



ELECTRICAL SHOCK

Do not use liquid or aerosol cleaners on the cutter. Do not spill liquid of any kind on the cutter. You can be severely shocked, killed or cause a fire. Use only a damp cloth for cleaning unless otherwise specified.

e) Lower the front safety shield.



INFORMATION

The machine will only operate with both E-STOPS in the up position and the safety Shield in the fully closed position.

8.4 Cleaning the control panels



ELECTRICAL SHOCK

Remove power from the cutter before cleaning. You can be severely shocked, killed or cause a fire.

- a) Use only a slightly damp (water only) non abrasive cloth.



ELECTRICAL SHOCK

Do not use liquid or aerosol cleaners on the cutter. Do not spill liquid of any kind on the cutter. You can be severely shocked, killed or cause a fire. Use only a damp cloth for cleaning unless otherwise specified.