



DELTA LAMINATOR OPERATOR MANUAL

Part Number: 930-116 Rev: - Rev Date: 7-19-04

US Version

©2004 GENERAL BINDING CORPORATION. ALL RIGHTS RESERVED.

Do not duplicate without written permission.



US Version

DELTA
Laminating Machine

OPERATOR MANUAL

Table of Contents

1.	SAFETY NOTICES.....	7
1.1	SAFETY NOTICES – COMPLETE MACHINE.....	7
1.2	SAFETY NOTICES – LOADING A STACK OF PAPER.....	9
1.3	SAFETY NOTICES – FEEDER HEAD HANDLING.....	10
1.4	SAFETY NOTICES – IN-FEED WHEELS AND GATE ADJUSTMENT.....	12
1.5	SAFETY NOTICES – ADJUSTABLE GUIDE PLATES ADJUSTMENT.....	13
1.6	SAFETY NOTICES – LAMINATING AND PRESSURE ROLLERS ZONE.....	14
1.7	SAFETY NOTICES – DECURLING BAR ADJUSTMENT.....	16
1.8	SAFETY NOTICES – SNAPPING ROLLER ZONE.....	16
1.9	SAFETY NOTICES – TWIN KNIFE.....	19
1.10	SAFETY NOTICES – MACHINE CLEANING.....	20
1.11	SAFETY NOTICES – SERVICE AND MAINTENANCE ELECTRICAL AND CONTROL SYSTEMS.....	20
2.	WARRANTY.....	21
3.	MACHINE TECHNICAL SPECIFICATIONS, DIMENSIONS, AND WEIGHTS.....	22
3.1	MACHINE TECHNICAL SPECIFICATIONS.....	22
3.2	MACHINE MAIN DIMENSIONS AND WEIGHTS.....	23
3.3	DIMENSIONS AND WEIGHT OF MACHINE WITH TRANSPORT PALLET.....	23
4.	MACHINE CONTROLS.....	24
4.1	CONTROL PANEL.....	24
4.2	MACHINE CONTROL DISPLAY.....	26
5.	MACHINE OPERATION.....	31
5.1	LOADING PAPER AND FILM.....	31
5.2	FILM ROLL POSITION ADJUSTMENT ON UNWINDING SHAFT.....	34
5.3	LAMINATING ROLL HEATING.....	35
5.4	PRESSURE MECHANISM.....	35
6.	SOLUTIONS FOR LAMINATING PROCESS PROBLEMS.....	36
7.	FEEDER – OPERATION AND ADJUSTMENT.....	39
7.1	FEEDER DESCRIPTION.....	39
7.2	SHEET OVERLAP ADJUSTMENT.....	39
7.3	SIDE GUIDES.....	40
7.4	FRONT LOADING.....	41
7.5	STACK POSITION.....	42
8.	FEEDER HEAD.....	43
8.1	FEEDER HEAD POSITIONING.....	43
8.2	FEEDER HEAD ADJUSTMENT.....	43
8.3	MINIMUM SHEET SIZE FEEDING.....	45
8.4	SHEET FEEDING PROBLEMS.....	45
8.5	FEEDER HEAD PROTECTION AGAINST FEEDER DAMAGE.....	45
9.	GATE I AND IN-FEED ROLLER MECHANISM.....	46
9.1	GATE I FUNCTION.....	46
9.2	IN-FEED ROLLER MECHANISM.....	47
10.	GATE II.....	53
11.	ADJUSTABLE GUIDE PLATES.....	53
12.	BECKER T4.25 DSK AIR COMPRESSOR.....	54
13.	SEPARATOR.....	55
13.1	DECURLING BAR.....	55
13.2	CHANGING DECURLING BAR RADIUS.....	56
13.3	PULL ROLLERS.....	57
13.4	TWIN KNIVES.....	59
13.5	SNAPPING MECHANISM.....	62
14.	STACKING TABLE.....	64
14.1	STACKING TABLE DESCRIPTION.....	64
14.2	STACKING TABLE POSITION ADJUSTMENT.....	64

- 15. MACHINE TRANSPORTATION 65
- 16. MACHINE INSTALLATION..... 66
 - 16.1 PREPARE BEFORE INSTALLATION 66
 - 16.2 ELECTRICAL INSTALLATION REQUIREMENT 66
 - 16.3 BECKER AIR COMPRESSOR 66
 - 16.4 MACHINE LOCATION..... 66
 - 16.5 FLOOR REQUIREMENTS 66

1. SAFETY NOTICES

1.1 SAFETY NOTICES – COMPLETE MACHINE

The following safety notices pertain to the operation of the machine.



WARNING

Obey the following precautions. Failure to do so can result in severe personal injury or damage the machine.

- All machine covers must be installed and closed when operating the machine. If all the covers are not installed or the safety switches do not function properly, the machine cannot be started or used.
- Never clean any rollers while the machine is in operation. In case it is necessary to turn the rollers for cleaning or inspection, use only the "SLOW FWD" or "SLOW REV" buttons.
- Use the "SLOW FWD" or "SLOW REV" buttons as follows:
 - a. Press the "SLOW FWD" or "SLOW REV" button.
 - b. After releasing the "SLOW FWD" or "SLOW REV" button, wait till the machine stops.
 - c. Start cleaning the rollers or other operation on the machine only when the machine is stopped.

CAUTION



Obey the following precautions. Failure to do so could result in minor personal injury or damage the machine.

- The machine cannot be operated by anyone under the influence of alcohol, drugs or some medications.
- If the machine operator feels sick or exhausted unexpectedly, the machine must be stopped.
- Check and test all three indicators of safety covers daily. These are:
 - a. The hinged laminating roller protective cover, snapping rollers movable protective cover, and movable protective cover (door) of the inner part under the laminating and snap section.
 - b. Two emergency stop buttons - one button on the control panel and one button on the drive side on the feeder.
- Be careful to not bump your head when switching on or off the compressed air or changing the air pressure on the main air pressure regulator.
- Be careful when you handle paper or work near the tightened web of paper with film. The sharp edges of the paper can cut.

Important

- The machine can be operated only by an operator who has been trained appropriately by a GBC service technician.
- The operator should use the primary and secondary stations to operate the machine. See the illustration in Section 1.1.1.
- The machine cannot be used for any work other than laminating paper.
- The type of film and paper must comply with the conditions given in Chapter 3, Technical Specifications.
- The machine has the necessary controllers for providing the laminating function. The controllers cannot be adjusted or modified otherwise than provided by the manufacturer.
- The machine must be placed on a solid and even surface. The operator's workstation must be at the same level as the machine.

Note

- Lighting should be adequate for the safe operation of the machine.

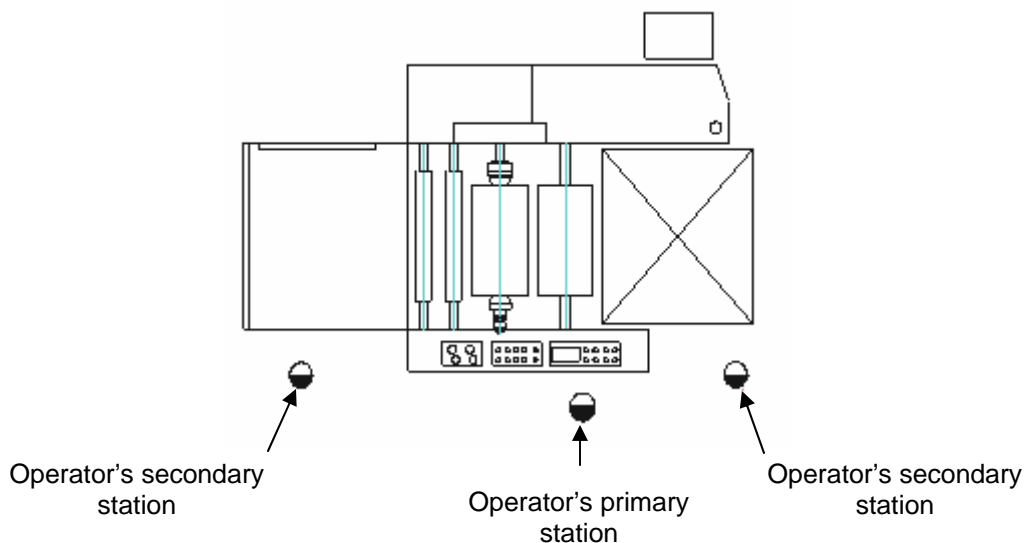
1.1.1 OPERATOR'S PRIMARY AND SECONDARY STATIONS

1.2 SAFETY NOTICES – LOADING A STACK OF PAPER

The machine is designed for feeding and laminating paper.



CAUTION

Obey the following precautions. Failure to do so could result in minor personal injury or damage the machine.

- Never handle the paper stack on the feeder if the machine is in operation. (Your fingers may get trapped during the automatic motion of the table).
- The paper should be loaded while the table is at the down position. Press the "STACK DOWN" button to move to the down position. (Otherwise you may get injured by the feeder head).
- Be careful while loading the paper stack on the table in the down position so that you do not hit your head on the feeder head.
- Move the table into the working position only by pressing and holding the "STACK UP" button.
- When the table moves, do not touch the table or the chain drives.
- Do not work under the table, so that you do not hit your head on the feeder table frame.
- The stack of paper has to be put on the table properly. It has to be pressed to the front guides and located between the side guides.

Be careful when handling paper!

CAUTION

CAUTION

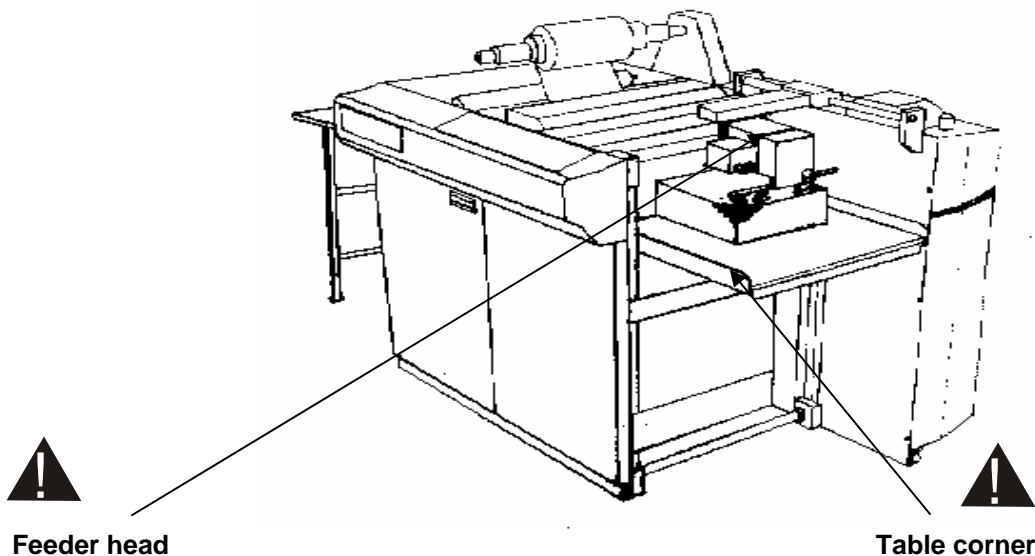

Feeder head

Table corner

1.3 SAFETY NOTICES – FEEDER HEAD HANDLING

The feeder head picks up a sheet of paper and loads it into the feeder rollers. It is necessary to change the position of the feeder head if the sheet size is changed.

CAUTION



Obey the following precautions. Failure to do so could result in minor personal injury or damage the machine.

- Do not hold on to the feeder head while the machine is in operation. The moving energy of the suction cups can injure the hands.
- Do not adjust the feeder head if the machine is in operation. The moving energy of the suction cups can injure your hands. The control buttons are the only exception.
- Do not handle the feeder head if the machine is not at rest. The control buttons are the only exception.
- To move the feeder head, loosen the clamp on the guide bar using the manual lever. Work carefully. A fast movement could result in hitting the drive cover.

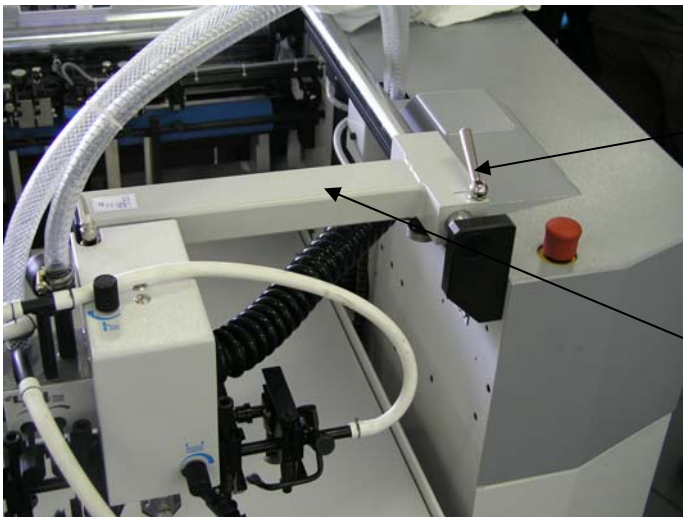

Manual lever

Hold it here if
you need to
move the head.

- To move the feeder head, turn the manual lever counter clockwise to loosen the clamp. Then move the upper arm continuously along the guide bar. Do not get your fingers near the guide bar. (The arm could hit the guide bar holder at the limit position).
- Do not put any objects on the top surface of the feeder head.
- Do not remove any covers. (The feeder head solid cover and protective rubber waved element).
- The regulating knobs can be turned even if the machine is running. Only a trained operator can adjust the machine.
- The operator should wear tight fitting clothes to prevent being pulled into the machine by the suction cups. Adjustments should be always done with only one hand.

*Regulating
knobs*



1.4 SAFETY NOTICES – IN-FEED WHEELS AND GATE ADJUSTMENT



CAUTION

- Do not handle the units in any way if the machine is in operation.
- The weights can be put in and taken out only if the machine is at rest. (You can get trapped with the feed roller while handling the in-feed wheels.)
- Always handle the rollers with the laminating roller Plexiglas cover down.
- While the machine is in operation, do not touch the in-feed mechanism.
- When the machine is turned off with the main switch, the accelerating wheels snap up 5/32 in. (4 mm). Turn off the machine with the main switch if the in-feed wheels are to be adjusted. You must be very cautious if the machine cannot be adjusted with the main switch turned off.

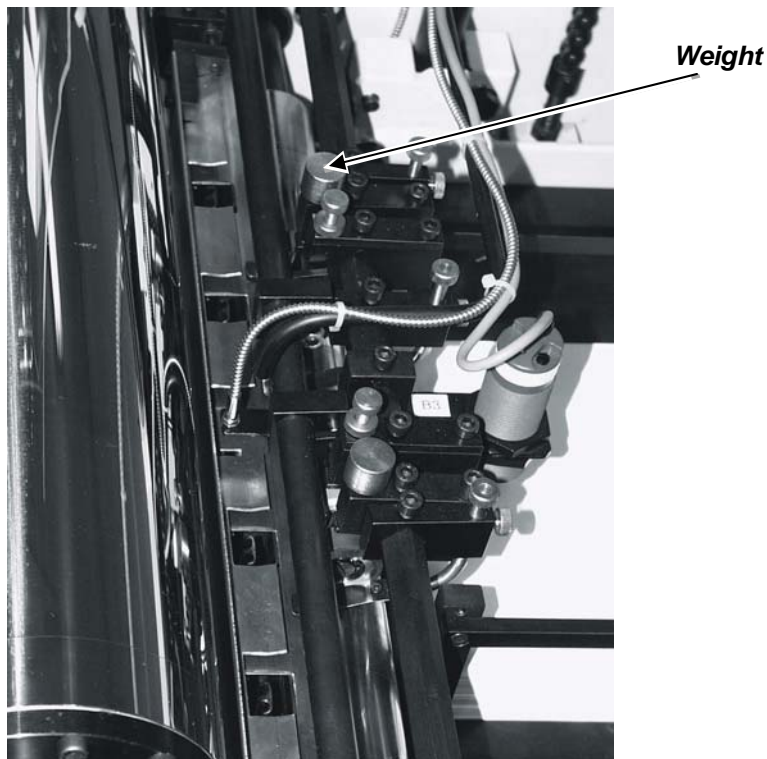

1.5 SAFETY NOTICES – ADJUSTABLE GUIDE PLATES ADJUSTMENT

The guide plates form paper in front of the laminating roller. The position of the plates has to be adjusted according to the different paper weight.



WARNING

Obey the following precautions. Failure to do so can result in severe personal injury or damage the machine.

- The position of the plates can be adjusted with the adjustment screw while the machine is in operation.
- The adjustment can be done only by an operator trained by GBC Service.
- The operator should wear tight fitting clothes to prevent possible trapping with the gate or feeder rollers. Always use only one hand for the adjustment.
- The adjustment must be done while the laminating roller cover is closed even if the machine is not in operation.

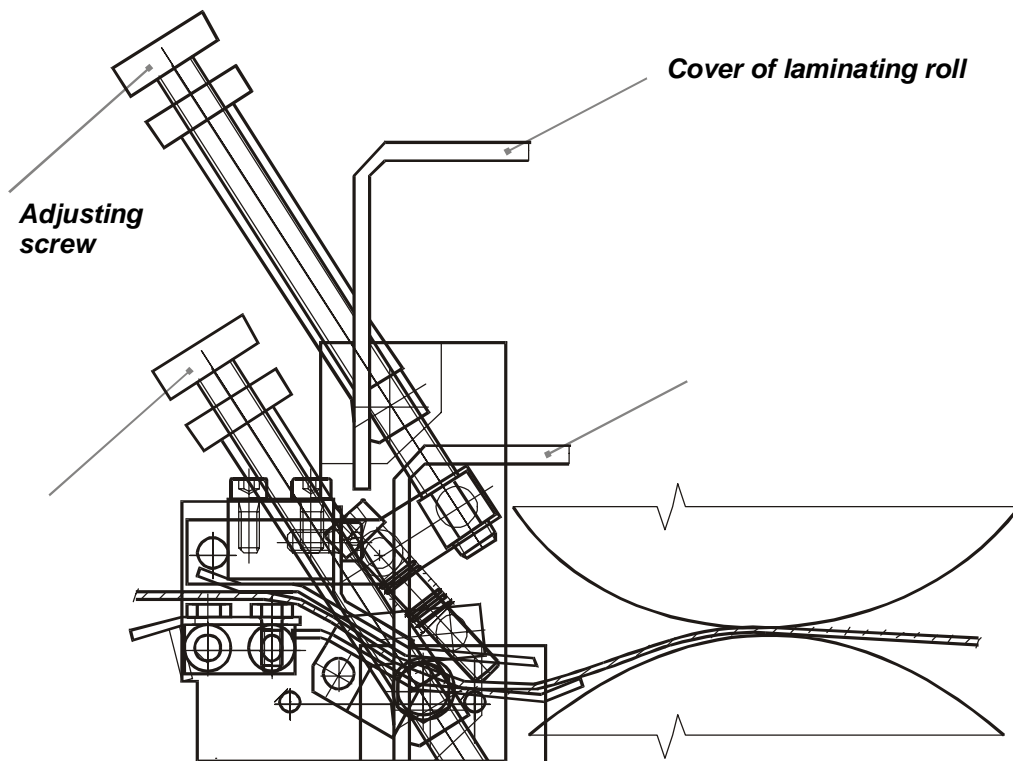

1.6 SAFETY NOTICES – LAMINATING AND PRESSURE ROLLER ZONE

The operating laminating roller temperature, depending on the type of laminating film, is 210 to 300 °F (100 to 150 °C). In order to maintain the machine function, it is not possible to cover all the zones near the laminating and pressure rollers. This is very hazardous due to the high temperature and crush hazard. Therefore the following precautions have to be followed strictly.



WARNING

Obey the following precautions. Failure to do so can result in severe personal injury or damage the machine.

- Never touch the hot laminating roller.
- Keep your hands and body away from the contact surface between the laminating roller and pressure roller where there is a crush hazard.
- When loading the first sheet of paper with film through the nip, keep your hands and fingers at least 8 in. (200 mm) behind the nip point of the laminating and pressure rollers. Failure to do so can cause severe injury.
- Use the "SLOW FWD" or "SLOW REV" buttons for cleaning. Never clean the surface of the rollers while the machine is in operation.
- Wear tight fitting clothing while working near the laminating and pressure rollers. Loose clothing can get caught in the moving rollers.
- Do not use any objects for cleaning the rollers or removing the film residue while the machine is in operation.
- The Plexiglas cover above the laminating roller must be closed while the machine is in operation. The cover cannot be dismantled or modified.



CAUTION

- To clean the rollers, follow "Machine Cleaning" given in Section 1.10.
- When the pressure roller is controlled to move up and down ("PRESSURE ROLL OPEN" and "PRESURE ROLL CLOSE" buttons), do not approach or touch the levers of the pressure roller near the pneumatic rollers and between the pressure roller lever and the cover of the screws near the laminating roller on the operator's side.
- If the Plexiglas cover of the laminating roller is opened, make sure it is fully opened so that the flat spring secures it.
- Before maintenance or adjustment, wait until the temperature on the roller surface drops below 100 °F (50 °C). To check it, do one of the following:
 - a. Use the temperature regulator display while the machine is in operation.
 - b. Use an external temperature contact measuring instrument.
 - c. Wait for 60 minutes after the roller heater is turned off.

Important

- Do not put any objects on the Plexiglas cover, which could deform or damage it or block the ventilation holes.

Side view from the operator's side

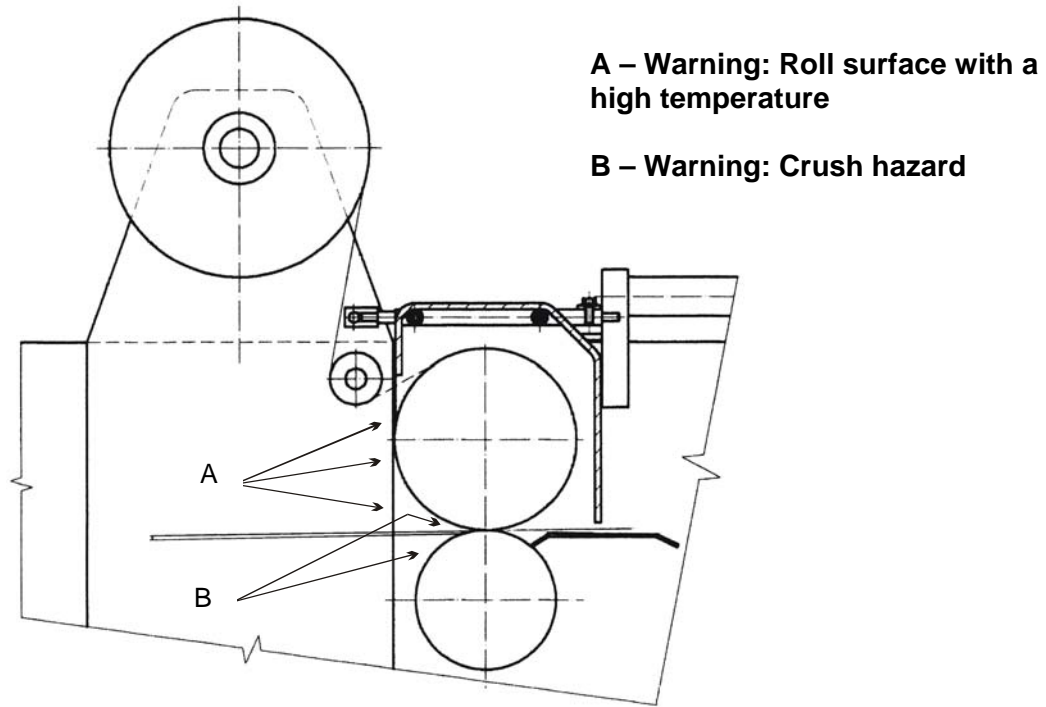

View of the laminating roller and pressure roller from the separator

Warning: Do not touch

Warning: High temperature on roll surface

Warning: Do not touch

Warning: Crush hazard

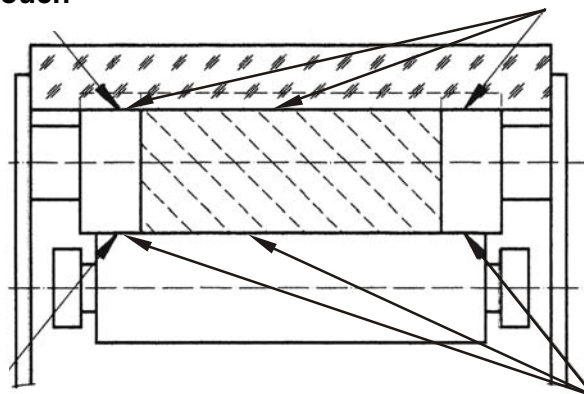

1.7 SAFETY NOTICES – DECURLING BAR ADJUSTMENT

During laminating there is an internal tension between the paper and laminating film causing it to curl up. The sheets are straightened by the decurling bar so that they will be straight after laminating.

The following safety rules must be observed while adjusting the decurling bar position.

Important

- Be careful while changing the control lever position. A fast movement of the control lever could hit the decurling bar locking lever.
- While changing the decurling bar position, do not get your fingers close to the slot in the regulating flange.

1.8 SAFETY NOTICES – SNAPPING ROLLER ZONE

In order to assure the machine functionality, it is not possible to cover the zone near the snapping roller completely. Therefore it is necessary to strictly obey the following safety rules.



WARNING

Obey the following precautions. Failure to do so can result in severe personal injury or damage the machine.

- Never adjust the snapping roller mechanism while the machine is running. If the levers of the upper snapping roller move, your fingers can get pinched between the levers and the Plexiglas cover.
- Keep your hands and body away from the surface between the upper and lower snapping rollers.
- The Plexiglas cover above the snapping roller must be always closed if the machine is in operation.
- If the snapping roller Plexiglas cover is opened, make sure it is fully opened so that the flat spring secures it.
- Do not remove the cover.

Important

- Do not put any objects on the top surface of the Plexiglas cover, which could deform or damage the cover.



CAUTION

Keep fingers away from pinch points between the lever and the cover when opening the cover.

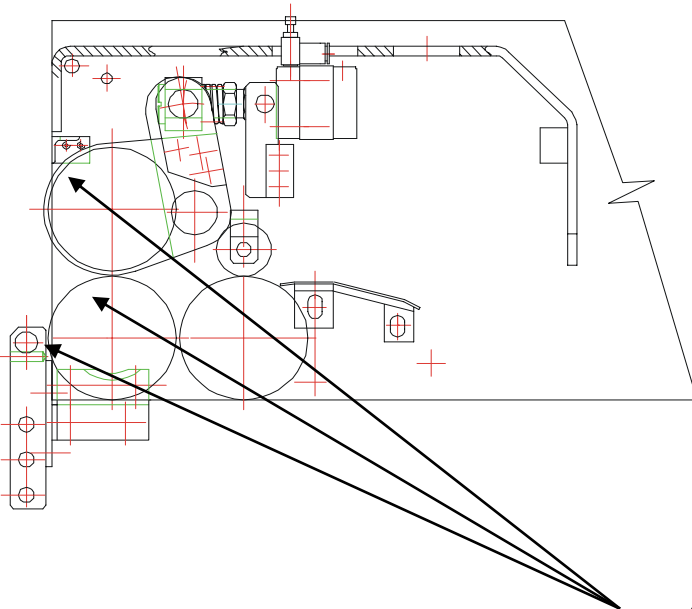

Separator (cross section)



WARNING

Keep fingers away when the machine is in operation.

View of the regulating screws from the stacking table



WARNING

Keep your fingers away when the machine is in operation. Pinching between the levers and the cover is possible.

View of the separator movable cover from the stacking table



WARNING

Keep your fingers away when the machine is in operation. Pinching between the cover edge and snapping roller is possible.

1.9 SAFETY NOTICES – TWIN KNIFE

The cutting knives are covered with Plexiglas at the top and at the sides. Since the knives are very sharp and they move very fast the following rules must be obeyed.

WARNING



Obey the following precautions. Failure to do so can result in severe personal injury or damage the machine.

- Never put your fingers or other part of the body close to the safety cover of the twin knives if the machine is in operation.
- Never put your fingers or any objects under the Plexiglas cover if the machine is not disconnected from the power supply.
- Use a 4 mm Allen wrench to adjust the knife position. The wrench can be put through the oval holes at the upper part of the twin knife Plexiglas cover.
- Do not touch the sharp edges of the knives during adjustment or changing of the knives. The knives can be held only away from the sharp edges.
- When handling the knives, put them in a safe place outside of the machine where no one can get injured.
- The solid safety Plexiglas cover must be installed every time when new or original knives are tested or adjusted.
- If another operation near the knife should be performed, disconnect the power supply.
- The Plexiglas cover must be always installed if the machine is in operation.
- The cover must not be modified otherwise than provided by the manufacturer.

Important

- Do not put any objects on the surface of the Plexiglas cover, which could deform or damage the cover.

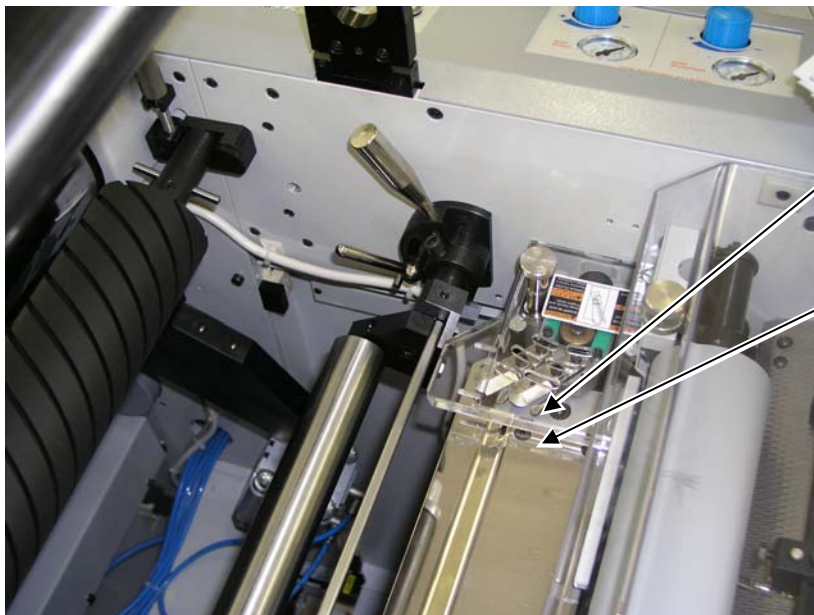

WARNING

Keep fingers away from the twin knives.

Twin knives move very fast under the Plexiglas cover.

1.10 SAFETY NOTICES – MACHINE CLEANING



WARNING

Obey the following precautions. Failure to do so can result in severe personal injury or damage the machine.

- Do not clean the machine if it is in operation.
- Use the "INCH" and "REVERSE" buttons turn the rollers to a different position for cleaning.
- Use the "INCH" and "REVERSE" buttons as follows:
 - a. Press the "INCH" or "REVERSE" button.
 - b. After releasing the "INCH" or "REVERSE" button, wait till the machine stops.
 - c. Start cleaning the rollers or any other operation only when the machine has stopped.
- Be very careful when cleaning the laminating rolls, because the roller surface temperature reaches 300 °F (150 °C). Always use rubber gloves for cleaning the laminating roller.
- Do not press the "PRESSURE ROLL CLOSE" button while cleaning the pressure roller or the machine if the operator's hands are close to the pressure roller arms.

Important

- Do not use aggressive solvents for cleaning the rubber coated rollers, which can affect or damage the rubber coating.

1.11 SAFETY NOTICES – SERVICE AND MAINTENANCE ELECTRICAL AND CONTROL SYSTEMS

Guidelines for Safe Maintenance

Only GBC Service is authorized to troubleshoot, repair, or adjust the electrical and control systems.

2. WARRANTY

GBC warrants to the original purchaser for a period of twelve months after installation that this laminator is free from defects in workmanship and material under normal use and service. GBC's obligation under this limited warranty is limited to replacement or repair, at GBC's option, of any part found defective by GBC without charge for material or labor.

THIS LIMITED WARRANTY IS IN LIEU OF ALL OTHER WARRANTIES EXPRESSED OR IMPLIED. WARRANTIES OF MERCHANTABILITY OR FITNESS FOR A PARTICULAR PURPOSE ARE EXPRESSLY EXCLUDED. ANY REPRESENTATIONS OR PROMISES INCONSISTENT WITH, OR IN ADDITION TO, THIS LIMITED WARRANTY ARE UNAUTHORIZED AND SHALL NOT BE BINDING UPON GBC. IN NO EVENT SHALL GBC BE LIABLE FOR ANY SPECIAL, INCIDENTAL, OR CONSEQUENTIAL DAMAGES, WHETHER OR NOT FORESEEABLE.

This limited warranty shall be void if the laminator has been misused; mishandled; damaged by negligence, by accident, during shipment, or due to exposure to extreme conditions; repaired, altered, moved, or installed by anyone other than GBC or its authorized agents; or if incompatible film was used. GBC's obligation under this limited warranty does not include routine maintenance, cleaning, adjustment, normal cosmetic or mechanical wear, nor freight charges.

Without limiting the generality of the previous paragraph, GBC's obligation under this limited warranty does not include:

Damage to the rollers caused by knives, razors, or other sharp tools; by any foreign objects falling into the working area of the laminator; or by cleaning the laminator with solutions or materials that harm its surfaces;

Damage caused by adhesives; nor

Damage caused by lifting, tilting or attempting to position the laminator other than rolling it on its castors across even surfaces.

For European Union Residents Only: This guarantee does not affect the legal rights which consumers have under applicable national legislation governing the sale of consumer goods.

FCC NOTE:

This equipment has been tested and found to comply with the limits for a Class A digital device, pursuant to part 15 of the FCC Rules. These limits are designed to provide reasonable protection against harmful interference when the equipment is operated in a commercial environment. This equipment generates, uses, and can radiate radio frequency energy and, if not installed and used in accordance with the instruction manual, may cause harmful interference to radio communications. Operation of this equipment in a residential area is likely to cause harmful interference in which case the user will be required to correct the interference at his/her own expense.

Changes or modifications not expressly approved by General Binding Corporation could void the user's authority to operate the equipment.

This Class A digital apparatus complies with Canadian ICES-003. (Cet appareil numérique de la Classe A est conforme à la norme NMB-003 du Canada.)

3. MACHINE TECHNICAL SPECIFICATIONS, DIMENSIONS, AND WEIGHTS

3.1 MACHINE TECHNICAL SPECIFICATIONS

3.1.1 PAPER SPECIFICATION

	US Version	EU Version
Maximum sheet size	20-1/2 x 28 in.	520 x 720 mm
Minimum sheet size	7-7/8 x 7-7/8 in.	200 x 200 mm
Paper weight	80 lb text to 24 pt	115 - 350 g/m ²

3.1.2 FILM SPECIFICATIONS

	US Version	EU Version
Types of suitable films	Polypropylene, Polyester, Nylon film	
Inner core diameter	2-1/4 x 3 in.	57 - 77 mm
Outer diameter of film reel	14 in.	350 mm
Film length per roll	10,000 ft.	3000 m

3.1.3 MACHINE SPECIFICATIONS

	US Version	EU Version
Maximum speed	65 ft./min	20 m/min
Minimum speed	6 ft./min	1.7 m/min
Laminating temperature	210 to 300 °F	100 to 150 °C
Height of feeder stack	25 in.	635 mm

3.1.4 NOISE SPECIFICATIONS

	US Version	EU Version
Sound pressure L_{pA}	77.9 dB (A)	
Sound pressure (impulse) L_{pAI}	80.6 dB (A)	
Equivalent noise level L_{Aeq}		75.3 dB (A)
Maximum noise level L_{Aeq} (max.)		79.8 dB (A)
Acoustic capacity level L_{WA}		87.7 dB (A)

3.1.5 ELECTRICAL CIRCUIT

	US Version	EU Version
Power input	6.5 kVA	6.5 kVA
Voltage	208-240 V, 60 Hz 3 Phase + Ground	400 V, 60 Hz 3 P + Ground + N
Nominal current	24 A	17 A
Recommended value of protection	30 A	25 A

3.1.6 PNEUMATIC CIRCUIT

	US Version	EU Version
Pressure pneumatic circuit	90 psi, 1.4 cfm	0.6 MPa, 40 l/min
Pneumatic circuit of feeder:		
Under pressure	- 8.7 psi	- 60kPa
Overpressure	+ 8.7 psi	- 60kPa

3.2 MACHINE MAIN DIMENSIONS AND WEIGHTS

	US Version	EU Version
Dimensions (Length x width x height)	100.4 x 48.5 x 53.2 in.	2550 x 1230 x 1350 mm
Floor space for machine operation	6.7 x 9.7 ft.	2.03 x 2.95 m
Machine foot print	33.9 ft ²	3.2 m ²
Weight	1895 lbs	860 kg

3.3 DIMENSIONS AND WEIGHT OF MACHINE WITH TRANSPORT PALLET

	US Version	EU Version
Transport pallet with machine (Length x width x height)	70 x 57 x 60 in.	1800 x 1450 x 1600 mm
Weight of machine with transport pallet	1984 lb	900 kg

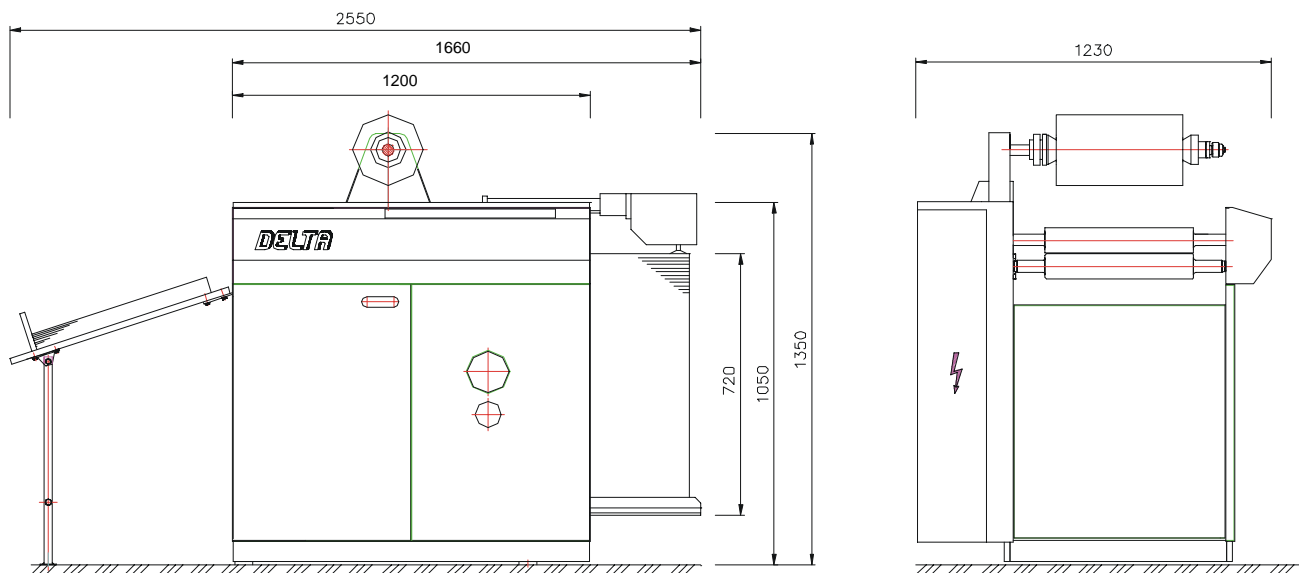

4. MACHINE CONTROLS

4.1 CONTROL PANEL

Refer to the Control Panel illustration on the next page.

KEY

1. Machine Start button
2. Machine Stop button
3. Machine speed potentiometer
4. Feeder – movement Up button
5. Feeder – movement Down button
6. Pressure roller – Closed button
7. Pressure roller – Open button
8. Machine error indicator
9. Laminating roller heater switch
10. Pull roller open/close switch
11. Knife motor Stop/Start switch
12. Snap mechanism – Impulse button
13. Snap motor – Stop/Start switch
14. Snap motor – Speed potentiometer
15. Inching – Slow forward
16. Inching – Slow reverse
17. Air compressor Stop/Start switch
18. Machine control display
19. Emergency stop button

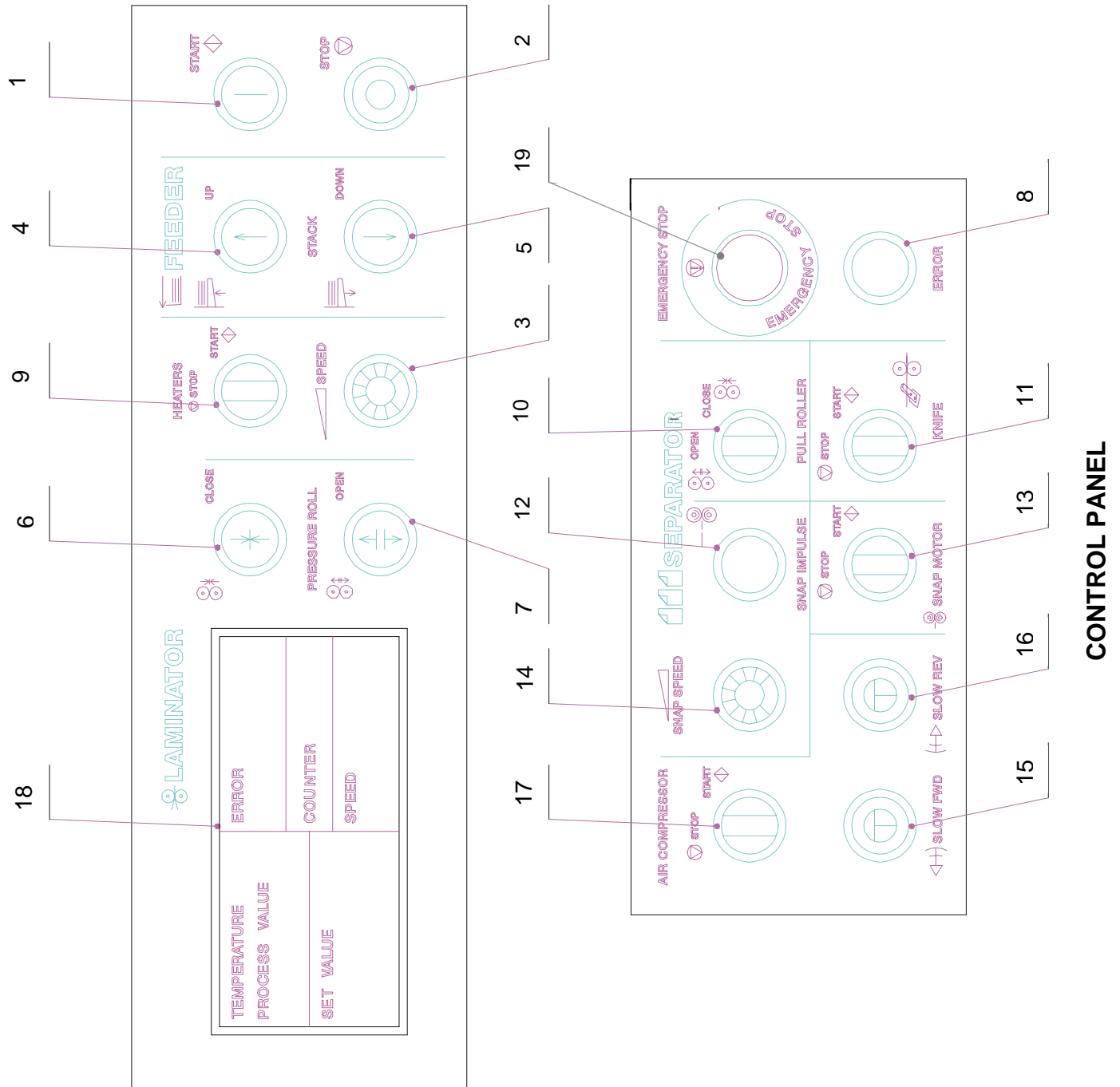

4.2 MACHINE CONTROL DISPLAY

4.2.1 Main Screen Functions

The main screen of the machine control displays shows the following functions:

- Actual machine speed (ft/min)
- Actual machine speed (histogram)
- Desired temperature (deg F)
- Desired temperature (histogram)
- Actual process temperature (deg F)
- Actual process temperature (histogram)
- Number of laminated sheets
- Machine status (No error/error)

4.2.1 Screen No. 2 Functions

The screen No. 2 of the machine control displays includes the following functions:

- Actual temperature of the middle and end roller sections (deg F)
- Snapping roller speed (ft/min)
- Button for lifting the accelerating wheels
- Laminated sheet counter functions – counting up or down

4.2.3 Screen No. 3 Functions

The screen No. 3 has the following functions:

- Total number of hours of operation (hrs)
- Total number of sheets in thousands (number of sheets)

4.2.4 Main Screen – Description

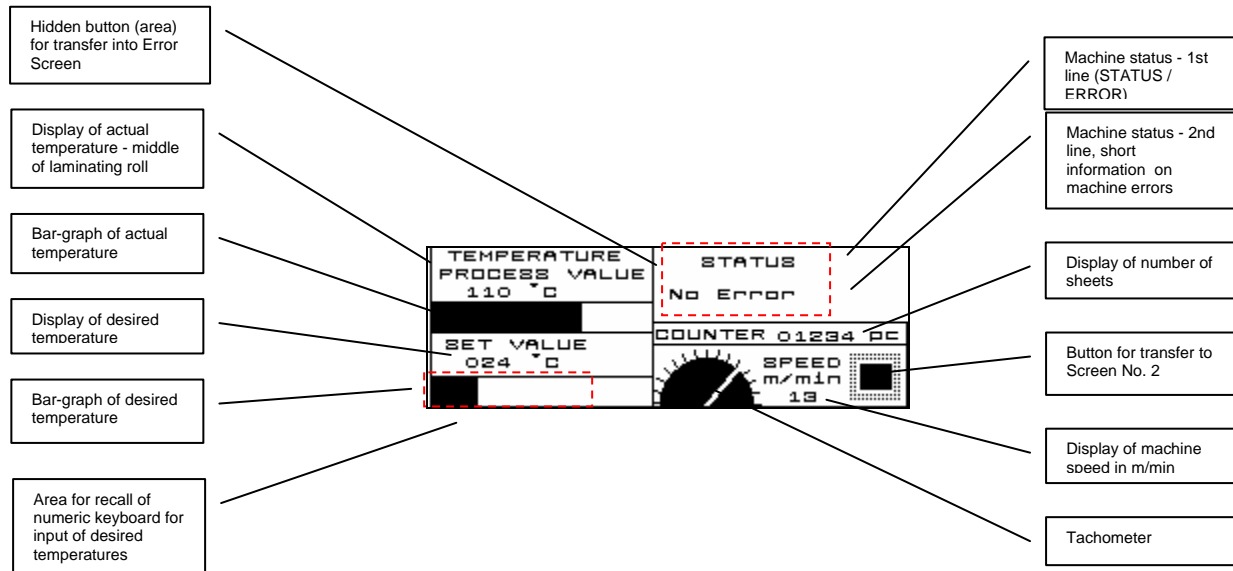

Procedure for setting the desired temperature:

1. Touch at the desired temperature in the area of the bar-graph to call the numeric button panel.
2. Enter the number of the desired temperature by pressing the buttons and confirm by pressing Enter. (Heating gets activated when the "HEATERS" switches are set to the "START" position).

4.2.5 Screen No. 2 Description

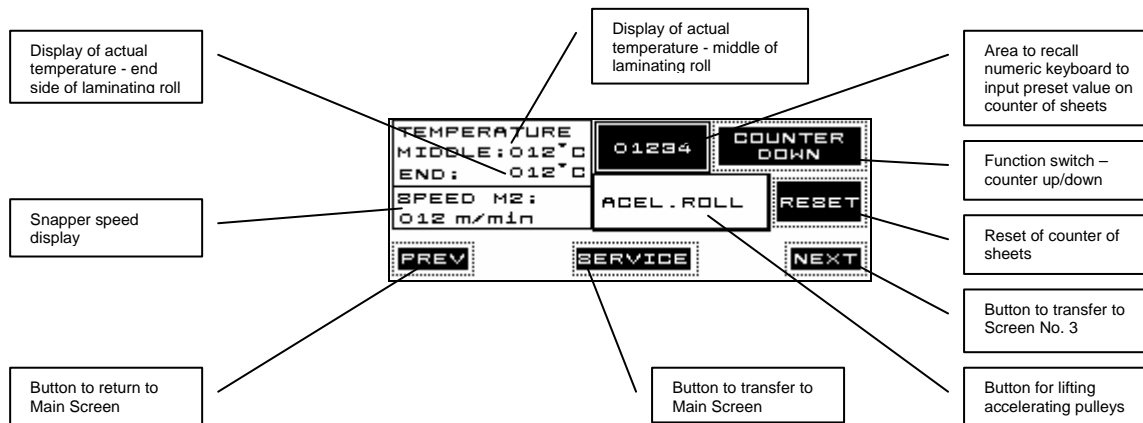

Counting sheets mode on the laminating machine

1. Counting up

The machine adds every pulse of the snapping roll to the preset value. As soon as 99999 is reached, the counter resets. If it is necessary to count from zero, set the counter value to 0.

2. Counting down

The machine deducts every pulse of the snapping roll from the preset value. As soon as 0 is reached, the machine stops. The following message will be displayed on the operator's panel:

- 1st status line – Status,
- 2nd status line - Count finished.

The preset value will rewrite in the sheet counter. Start the laminating machine by pressing the “START” button.

3. Counter reset

By the “RESET” button on the operator's panel.

Accelerating pulleys lift

If the accelerating pulleys are pushed down to a sheet of paper, lift them with the “ACEL.ROLL” button. The laminating machine must be in the operational stop (i.e. the main motor is not turning). After pressing the “ACEL.ROLL” button again, the accelerating pulleys are pushed down to the sheet of paper.

4.2.6 Screen No. 3 Description

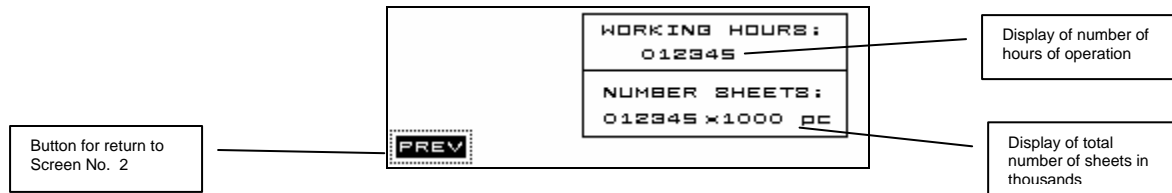

4.2.7 Error Screen Description

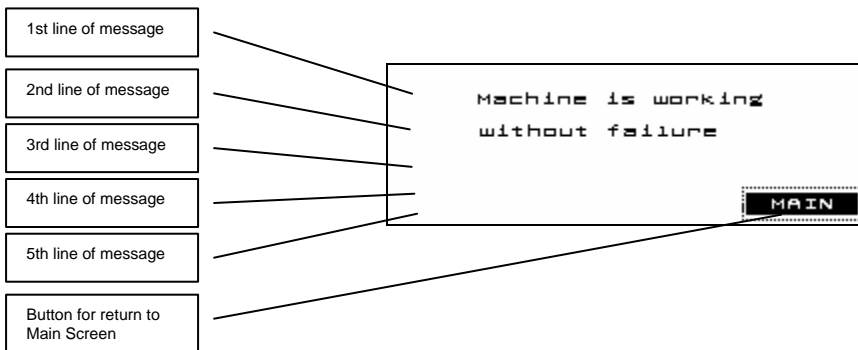

Procedure for transferring to the Error Screen:

- Touch in the 1st and 2nd status line to get in the Error Screen.

Procedure for transfer to Screen No. 2

- Touch the button in the bottom right corner of the operator's panel to get into Screen No. 2.

5. MACHINE OPERATION

5.1 LOADING PAPER AND FILM

1. Set up the side guides and the feeder head position

- Put one sheet of the paper and, according to the width of the sheet, set up the side guides as described in Chapter 7.3.
- Set up the feeder head position according to the sheet length as described in Chapter 8.1.
- Set up upper guide plates as described in Chapter 9.2.3 if needed.
- Set up the adjustable guide plates according to the paper thickness as described in Chapter 11.

2. Set up the sheet overlap.

- Set up the sheet overlap according to the sheet length as described in the overlap adjustment procedure as follows.

Important

NEVER TURN THE KNOB IF THE MACHINE DOES NOT RUN.

- Start the machine.
- Set the machine to a slow speed.
- Set the arrow on the dial (**u**) with the manual knob (**t**) to the value, which corresponds to the requested sheet length.

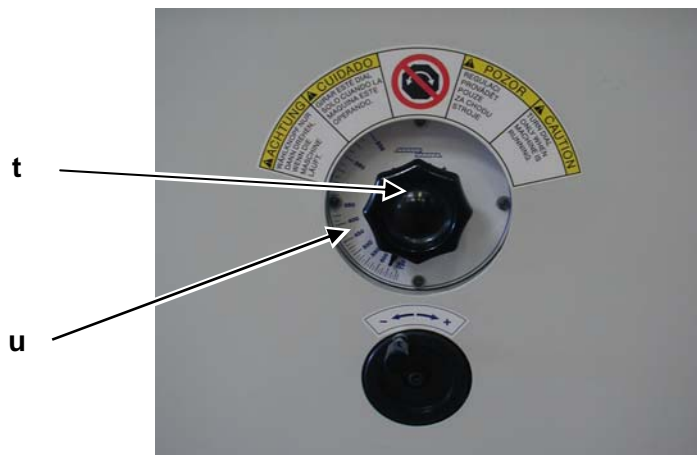

- Lift the feeder table into the working position.
- Switch the compressor to on and turn the machine on with the "START" button.
- Stop the machine when the first sheet of paper goes under the laminating roll and the front edge of the sheet is a minimum of 7-7/8" (200 mm) behind the contact surface between the laminating roll and pressure roll.

Note: Refer to the illustration on the next page for the remaining steps, which follow the illustration.

3. Check for the film adhesive side "Poly - out" or "Poly – in."

One side of the film is coated with an adhesive. It can be checked:

- Visually - the side coated with adhesive is not as glossy as the other side.
- By placing the film on the edge of the laminating roll - the adhesive side of the film will stick.
- According to the color stripe on a new film (red or blue).

Depending on the coated side of the film, the roll of film is put on the unwind shaft.

4. Positioning the roll of film on the unwinding shaft.

- a. Adjust the thread bushing by turning the regulating nut so that the white stripe on the holder runs along the edge of the sliding nut –See Section 5.2
- b. Tighten the reel with the conical holders so that the film centered with the paper sheet in the feeder. This distance should be measured from the sides.

5. Put a sheet of paper onto the beginning of the film.

In order to make it easier to insert the film, tape a sheet of paper onto the film and thread it through the nip.

6. Inserting the film.

- a. Insert the film around the guide roll, over the laminating roll according to the "FILM INSERTING PLAN and its "Poly- out" or "Poly - in" illustration. Refer to the illustration following this section.
- b. Put the sheet through the gap between the laminating and pressure rolls so that paper will be minimum 8 inches (200 mm) behind the contact surface of the rolls. ATTENTION! Follow the safety rules for the Laminating and Pressure Roll Zone, Chapter 1.6.

7. Press the "PRESSURE UP" button.

The "PRESSURE UP" button can be pressed when a sheet of paper from the feeder and a sheet of paper with film have gone between the rolls and you hold both sheets.



WARNING

Keep your hands and fingers at least 8 in. (200 mm) behind the nip point of the laminating and pressure rollers. Failure to do so can cause severe injury.

8. Inserting paper with film in the separator.

- a. Let two or three sheets go through the laminating section at the minimum speed.
- b. Cut off the stuck sheets and put the film belt with paper between the separator rolls.
- c. Turn the "Pull roller" switch to "Close."

9. Turn on the Knife and Snapping section.

- a. When sheets are behind the snapping rollers turn switch for the knife in the position Start.
- b. When next sheet overlap is in the middle of the distance between the pull rollers and the snapping rollers push the Snap Impulse button and sheet separation will start.

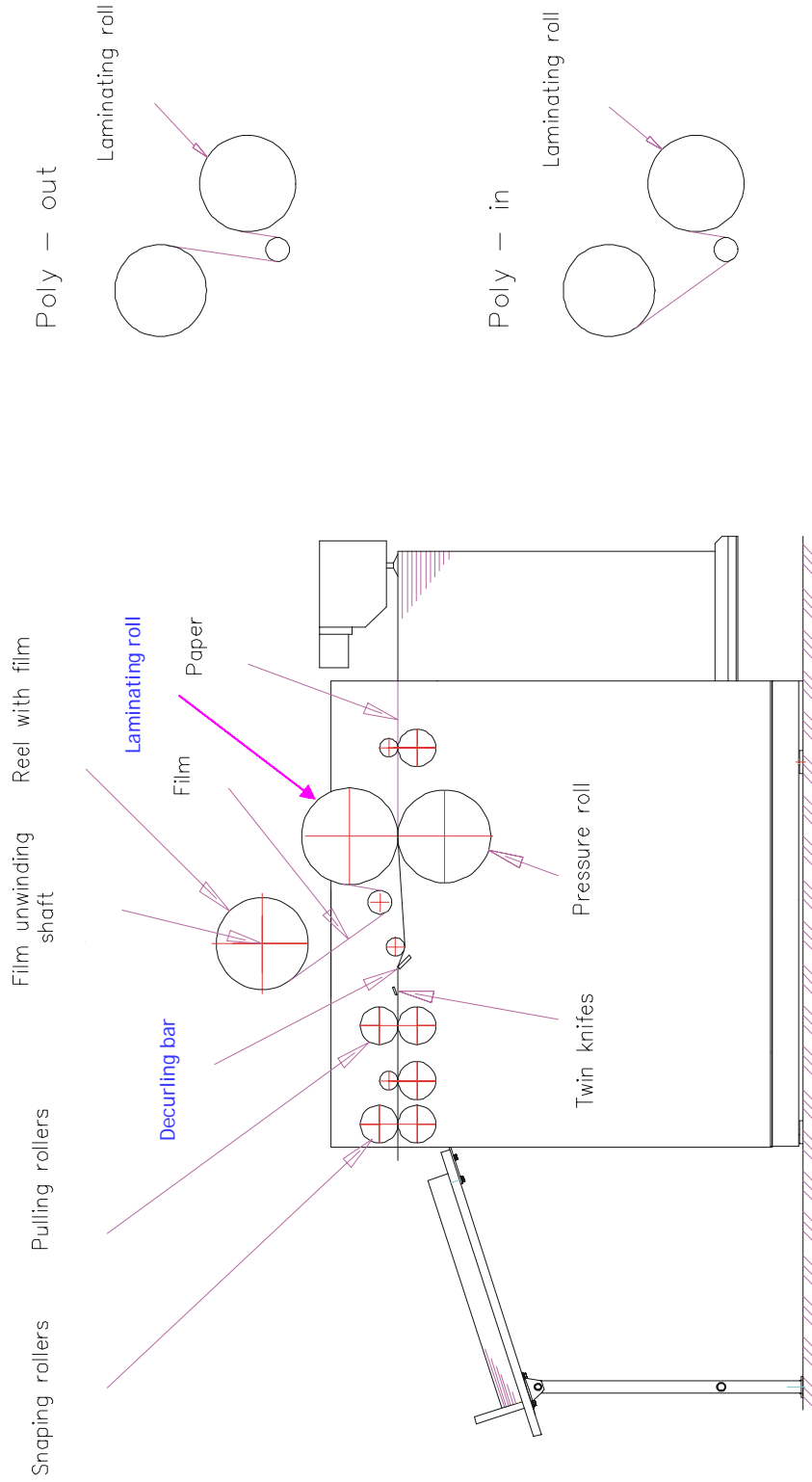

FILM INSERTING DIAGRAM

5.2 FILM ROLL POSITION ADJUSTMENT ON UNWINDING SHAFT

If you insert a new roll of film, which has a different width than the original one, proceed as follows:

1. Adjust the regulating nut of the film lateral movement (a) so that the front edge will be placed with the the white line on the thread.
2. Turn the tightening nut on the conical holder (c) on the driving side to its initial position (i.e. as close as possible to the conical holder) (e).
3. Loosen screw M8 on the conical holder (d) on the operator's side and take the cone out of the unwinding shaft (b).
4. Check if the side of the film with adhesive is on the outer or inner film side. Depending on film coating "POLY IN" or "POLY OUT," put the film reel on the unwinding shaft (b) as specified in the previous illustration, "FILM INSERTING DIAGRAM."
5. Put the conical holder on the operator's side on and tighten the screw slightly. Support the unwind shaft with a support (f).
6. Adjust the reel position according to the illustration below. The distance between the point of the film reel and the support (f) is given by the size of the gap between the stack of paper and the side plate on the operator's side, plus the width of the edge of paper that is not laminated.

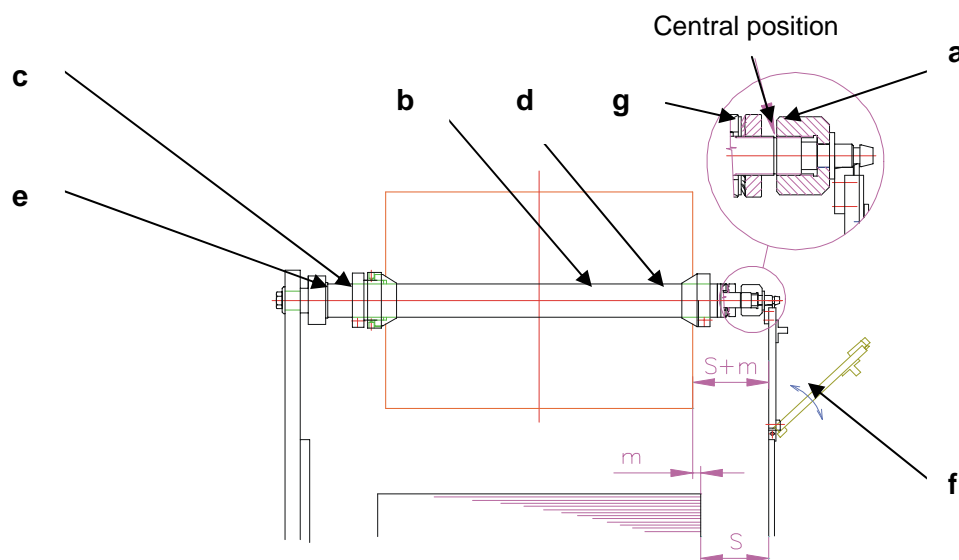

7. Tighten screw M8 on both conical holders.
8. Tighten the nut on the driving side so that the film roll will not slip on the conical holders when the brake is applied.
9. Regulate the braking force of the unwind according to the film roll weight and speed of laminating (g).

5.3 LAMINATING ROLL HEATING

Each type of laminating film and adhesive have specific temperature range requirements. The required temperature depends upon the thickness of the paper, line speed, film, humidity, ink coverage, type of ink, and other factors. Testing of good film adhesion should be done before production occurs. The laminating temperature range is 210 to 300 °F (100 to 150 °C).

5.4 PRESSURE MECHANISM

The pressure mechanism is important for correct adhesion. Depending on the desired final laminating quality, it may be necessary to change the pressure of the pressure roll against the laminating roll. The machine manufacturer recommends using a pneumatic pressure ranging from 0.2 to 0.6 MPa. The pressure is adjusted with regulators I and II.

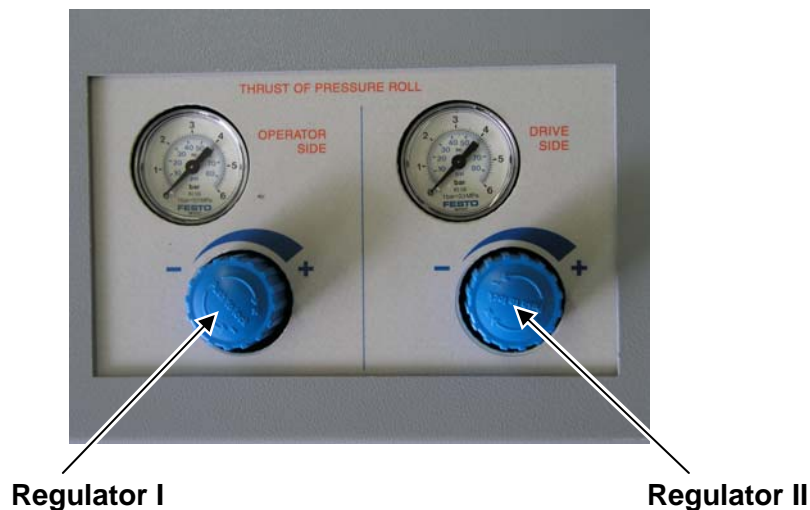

The pressure can be adjusted separately on the left and right side of the pressure roll.

The pressure roller drops down:

- 20 seconds after pressing the "STOP" button (to stop the machine) on the control panel.
- Immediately after pressing "emergency button."
- Immediately after a electricity failure.

6. SOLUTIONS FOR LAMINATING PROCESS PROBLEMS

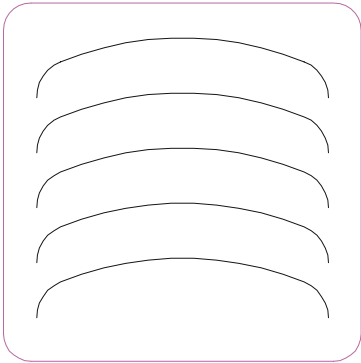

Illustration 1

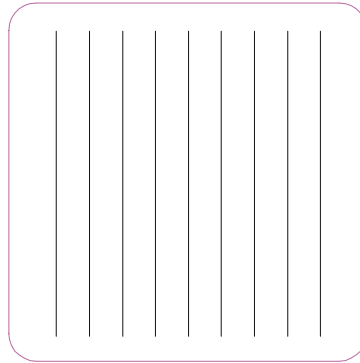

Illustration 2

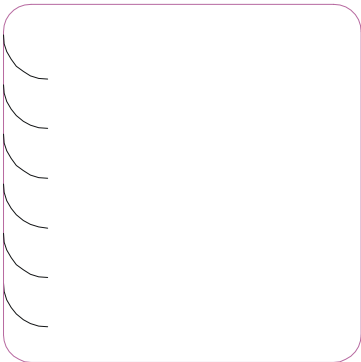

Illustration 3

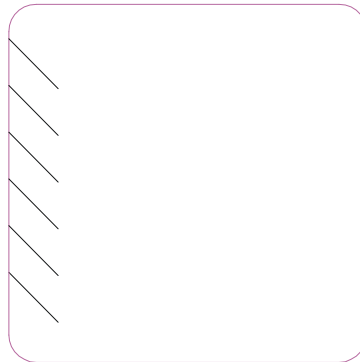

Illustration 4



Illustration 5

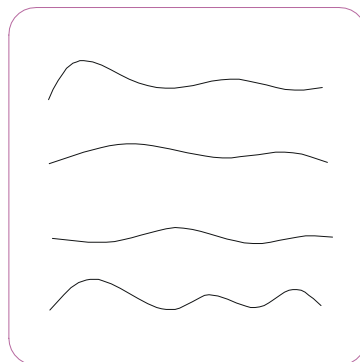

Illustration 6

- ILLUSTRATION 1 - wet paper
- brake of laminating film unwinding shaft is too tight
- ILLUSTRATION 2 - high laminating temperature
- wet paper
- brake of laminating film unwinding shaft is too tight
- excessive pull of pull rollers
- ILLUSTRATION 3 - incorrectly set pressure of pressure roll
- incorrectly set drifting roll
- incorrectly set stop of upper pull roller
- incorrectly set eccentric case
- margin zone of laminating roll is not heating if a wider format is laminated
- ILLUSTRATION 4 - incorrectly set pressure of pressure roll
- incorrectly set drifting roll
- brake of laminating film unwinding shaft is loose
- margin zone of laminating roll is not heating if a wider format is laminated
- incorrectly set eccentric case
- incorrectly set stop of upper pull roller
- ILLUSTRATION 5 - brake of laminating film unwinding shaft is too tight
- paint or dirt on pressure roll or laminating roll
- ILLUSTRATION 6 - laminating roll is not heated
- laminating roll is overheated
- excessive pressure on laminating film
- brake of laminating film unwinding shaft is loose

Problem: STRIPE ON THE LAMINATED SHEETS RUNNING ACROSS

Solution: The stripe running across is caused by the decurling bar.

The cause can be removed:

- By turning the decurling bar to the larger radius position
(Changing the decurling bar radius is described in Chapter 13.2)
- By increasing the pressure on the pull rollers where the sheets slide between the pull rollers when they are separated (an adjustment of pull roller pressure is described in Chapter 13.2)

Problem: IF POLYPROPYLENE FILM IS USED, THE SHEET WEB SPLITS BETWEEN THE LAMINATING SECTION AND SEPARATOR

Solution: The problem is caused by excessive tension by the pull rollers.

The cause can be removed:

- By reducing the separator pull rollers pressure (Adjustment of pull roller pressure is described in Chapter 13.2)

Problem: **THE SHEETS ARE RAGGED ON THE SIDE BY THE SEPARATOR KNIFE**

Solution: The problem is caused by:

- Too small gap between the sharp blade edge and guide pin

Two clamping screws M5 on the knives have to be loosened, the knife turned off the guide pins, and then the screws must be tightened again.

If turning the knives will not resolve the problem, the knives have to be raised up by forming metal sheet inserts 0.01 in. (0.3 mm thick). (Explanation on the knife position is given in Chapter 13.3.)

7. FEEDER – OPERATION AND ADJUSTMENT

7.1 FEEDER DESCRIPTION

The main sections of the feeder are the lifting mechanism, table, feeder head, front guides, gate I, side guides, in-feed wheels, and gate II. The feeder table is not removable. It is controlled by chains and guided on two guide bars. The sheets are taken off the table and loaded in the machine by the feeder head. During laminating, paper is taken off the top of the stack. The feeder head sensor checks the stack height and controls the lifting mechanism. The feeder table is lifted automatically depending on the paper withdrawal. One lifting step is 5/64 to 1/8 in. (2 - 3 mm). The movement of the feeder table is either automatic controlled by the feeder head foot or by buttons on the main control panel. Refer to the illustration in Chapter 4.1.

"STACK UP" (4) - the table will move up

"STACK DOWN" (5) - the table will move down

7.2 SHEET OVERLAP ADJUSTMENT

After any change of the sheet length, it is necessary to change the speed of the feeder head. This is done by turning the regulator knob (t) manually.

Important

NEVER TURN THE KNOB IF THE MACHINE DOES NOT RUN.

Proceed as follows:

1. Start the machine.
2. Set the machine to a slow speed.
3. Set the arrow on the dial (u) with the manual knob (t) to the value, which corresponds to the requested sheet length.
4. Check the sheetoverlap.
5. If a smaller overlap is required, turn the knob (t) slightly in the direction of the – arrow (counterclockwise) shown on the sheet size label.
6. If a bigger overlap is required, turn the knob (t) slightly in the direction of the + arrow (clockwise) shown on the sheet size label.
7. Wait until 2 to 4 sheets are loaded after turning the knob (t) and only then adjust more. The drive conversion unit is slightly delayed.

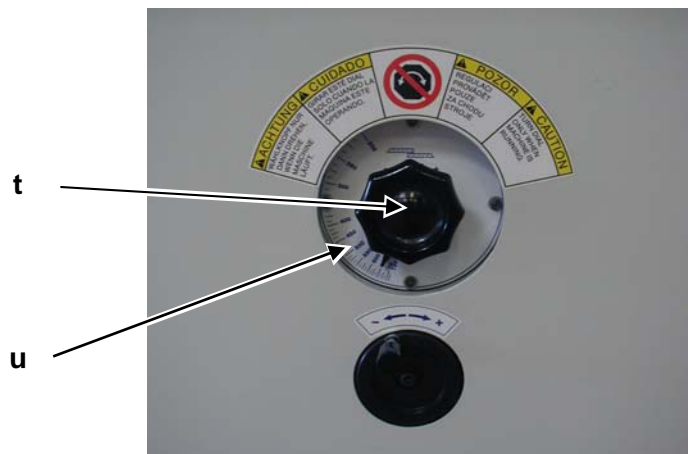

7.3 SIDE GUIDES

The side guides center the paper stack (c). They are symmetrically adjusted to the machine center. There has to be slight clearance between the side guide strips and paper stack so that the strips will not damage the paper and will not cause improper sheet feeding. The side guides are controlled by the handle on the operator's side (d). The arrow (e) represents the turning direction if the side guides position needs to be changed. If the sheet width is narrower, use –, if the sheet width is wider, use +.

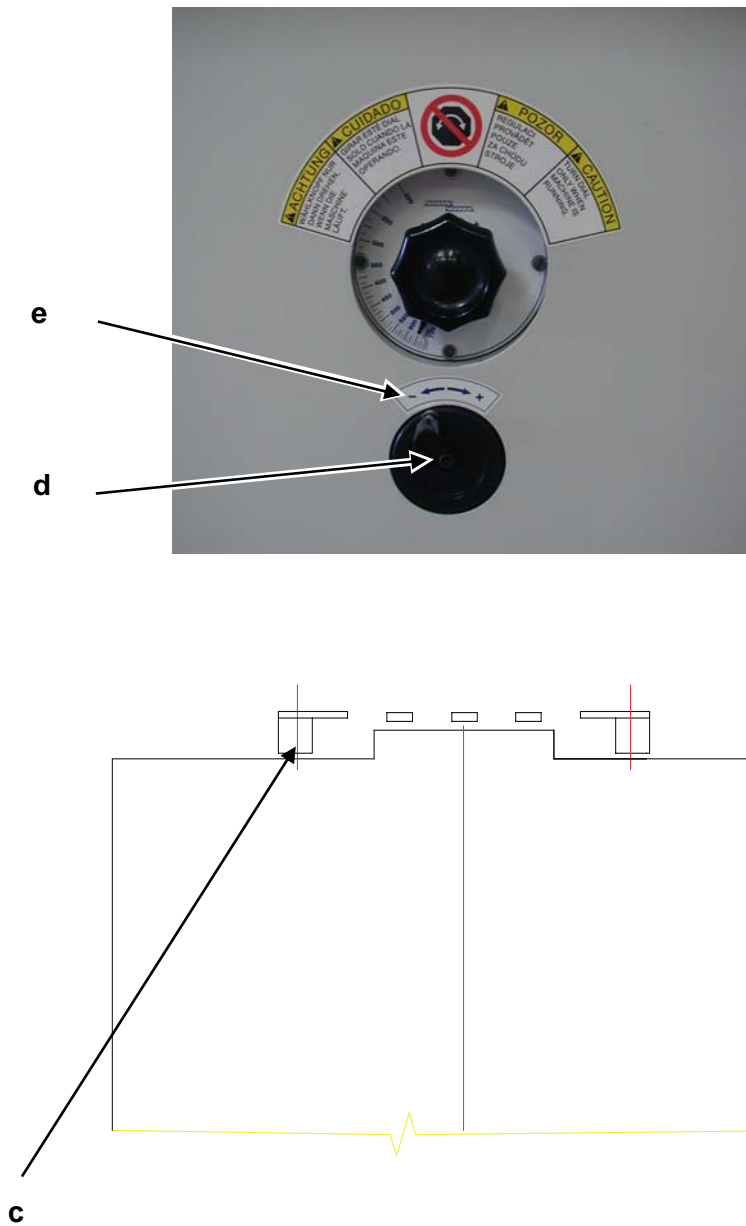

7.4 FRONT LOADING

The correct front position of a paper stack on the feeder is assured by the front guides (**a**) and gate I stops (**b**). The sheets have to be pressed against the surface of the front guides. Be careful to prevent paper bending, which could cause problems during feeding.

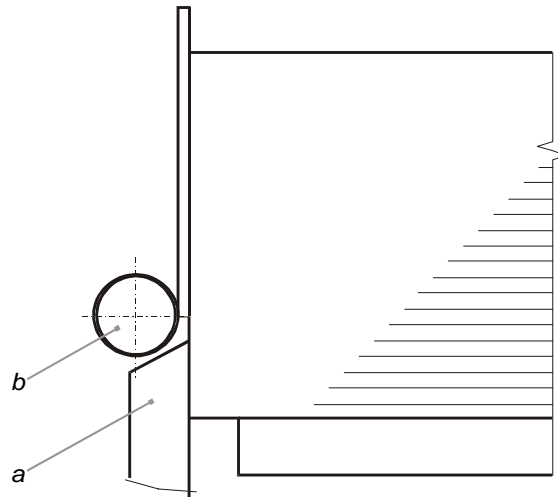

7.5 STACK POSITION

When a paper stack is loaded, press the "STACK UP" button. The table (f) will lift and its top position will be determined by the capacity sensor (g). The paper pile should stop 15/64 in. (6 mm) from the top of the gate I.

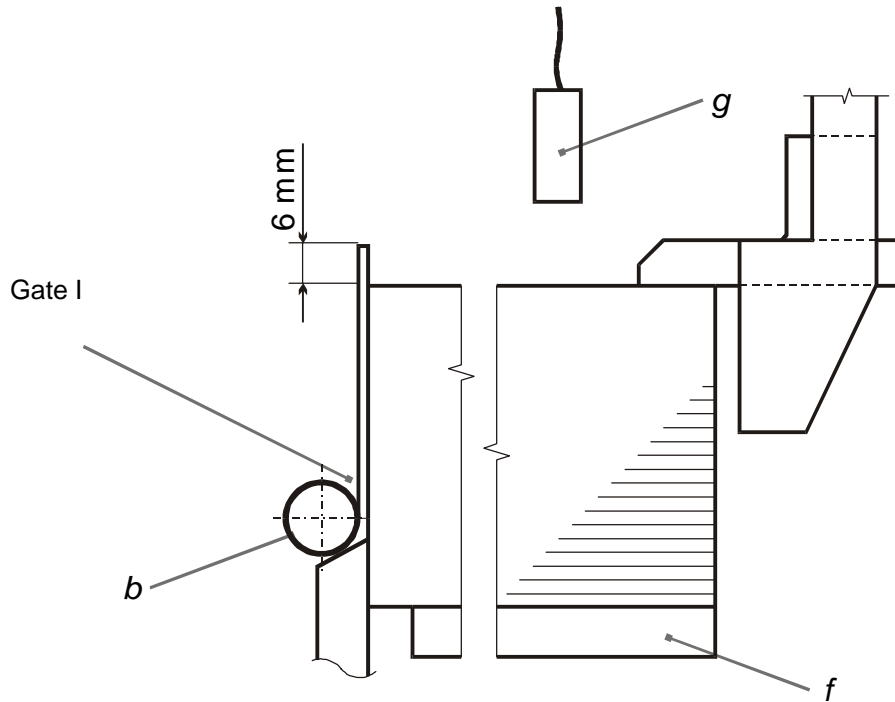

8. FEEDER HEAD

8.1 FEEDER HEAD POSITIONING

Loosen the clamp with the handle (a). Move the head to the rear position (off the machine). Lift the table with a paper stack to the working position by pressing the "STACK UP" button. (See the illustration in Chapter 4.1.) Move the head so that the rear stops (b) will touch the rear edge of the paper stack slightly and then tighten the handle (a).

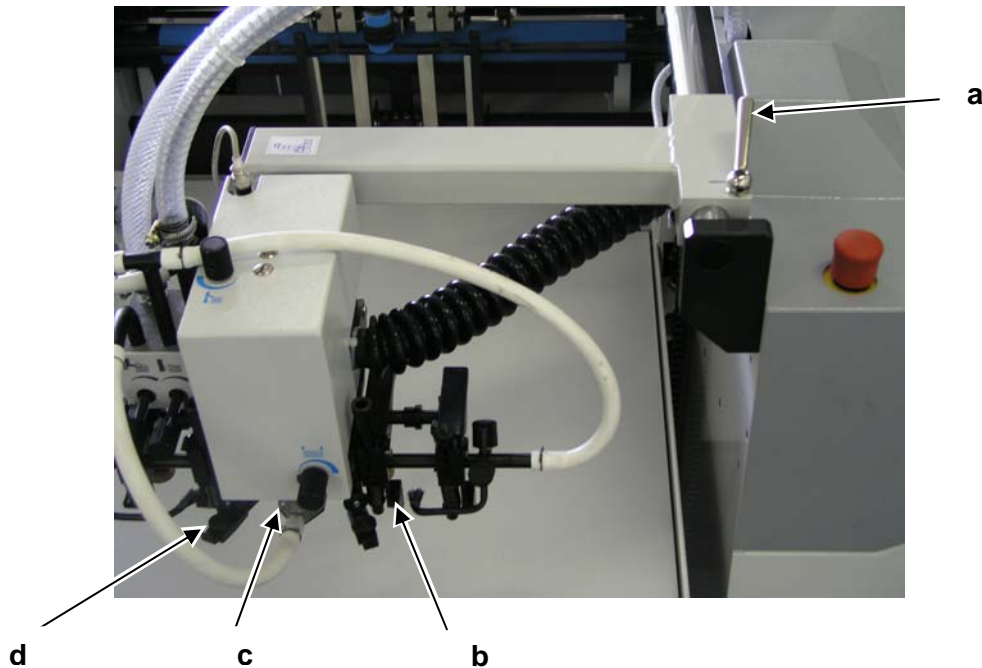

8.2 FEEDER HEAD ADJUSTMENT

The feeder head foot (c) has to be on top of the paper stack. Move the flat springs (d) onto the stack so that their front edge will exceed the paper edge by approximately $5/32$ to $9/32$ in. (4 to 7 mm) and so that they will be located by $5/32$ to $15/64$ (4 to 6 mm) above the stack. The height of the flat springs (d) have to be adjusted so that separating the different sheets will be assured.

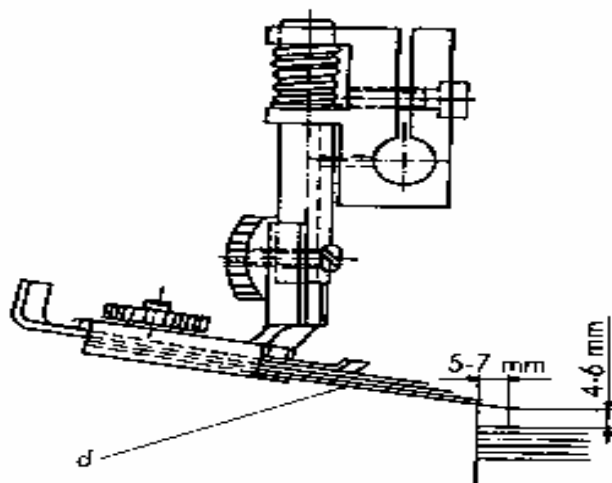

- The brushes (**e**) should exceed the paper edge by 5/64 to 7/64 in. (2 to 3 mm) and they should sit on the paper only lightly to prevent blowing the paper out. (Use only brushes instead of flat springs for a heavier paper weight.)
- Adjust the pipe blow (**f**) with the nut (**g**) so that 10 to 20 sheets at the top will be blown.
- Adjust the inner suction cups by deflecting the plot (**ch**) so that the paper sheets between the suction cups will be tightened.
- Adjust according to the type of paper the vacuum that is necessary for the sheet intake by the transport suction cups with the regulator. The regulator is located on the air compressor. Check the vacuum value on the manometer (**i**). Refer to the photo in Chapter 8.3.
- The regulators (**j**) and (**k**) are used for adjusting the requested pressure of air for blowing the sheets apart.
- The regulator (**l**) is used for adjusting the stack working height in the automatic mode.

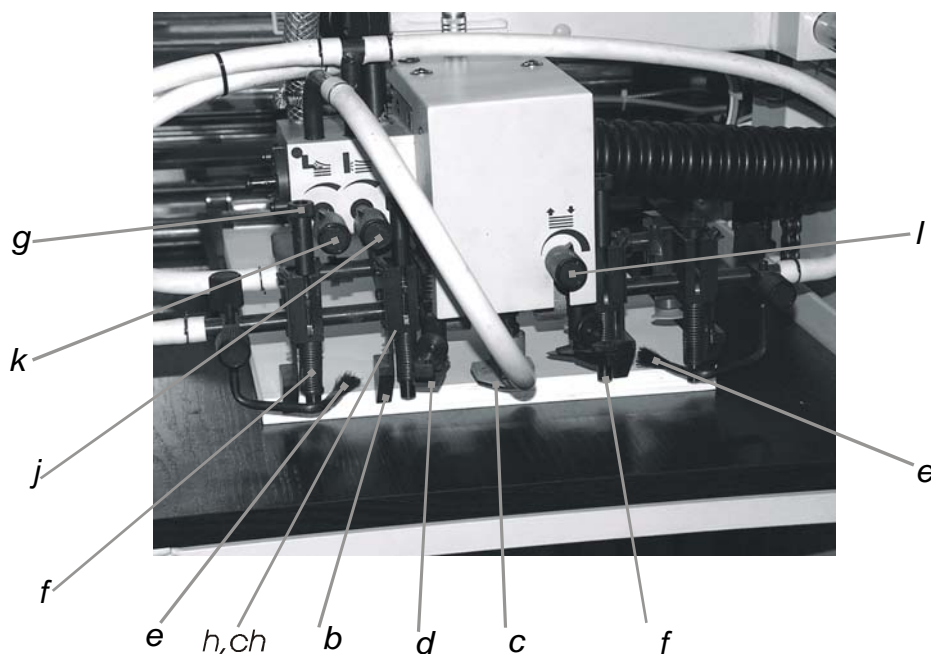

8.3 MINIMUM SHEET SIZE FEEDING

When the width of a sheet is smaller than the pitch of the internal suction cups (**m**), it is necessary to loosen the screw (**n**) and then to turn the internal suction cups forward by 90°. The suction cups will be out of operation. Turning is also necessary in order to prevent hitting the outer suction cups on the side guides.

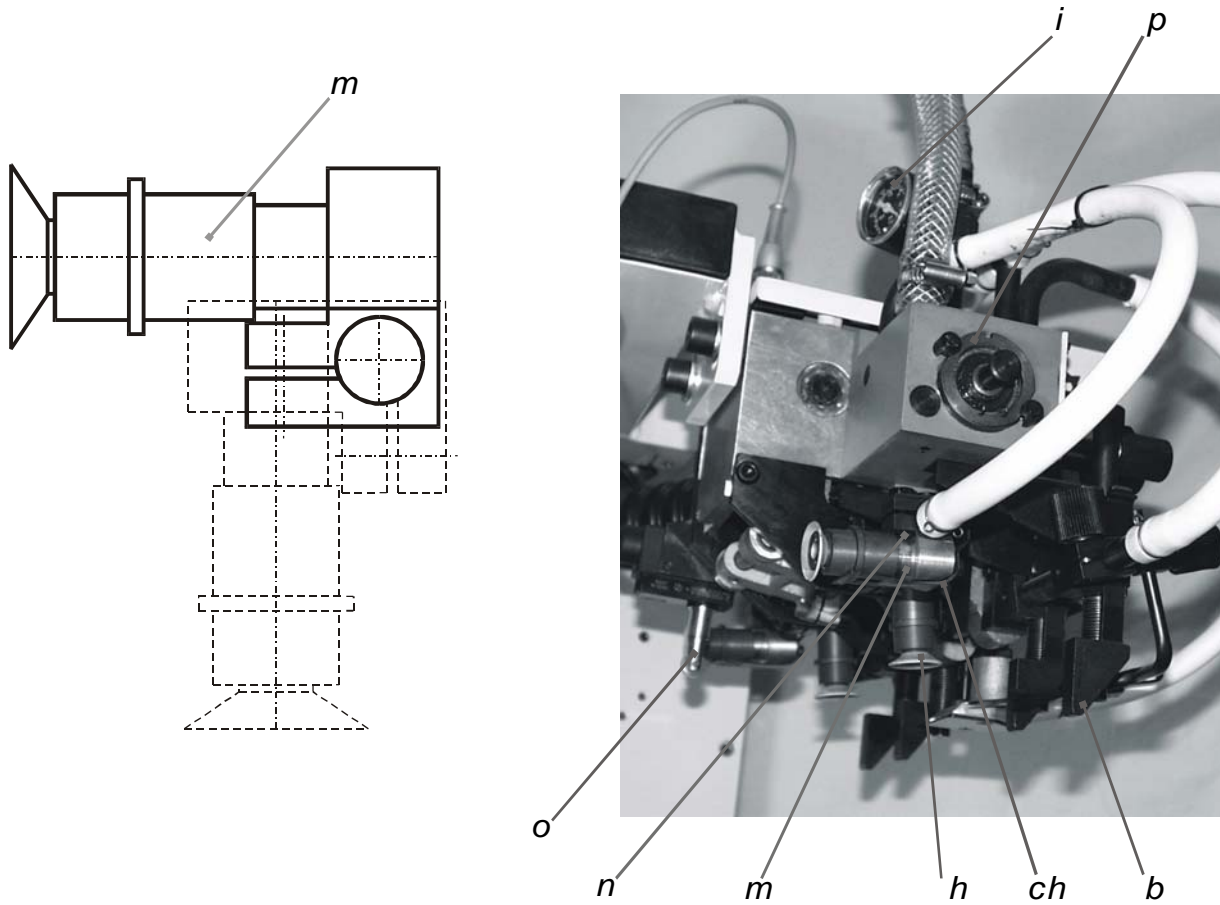

8.4 SHEET FEEDING PROBLEMS

- Paper is not acclimated.
- Incorrect underpressure and pressure.
- Paper is not cut off due to a dull knife. The stack has to be shaken.
- The side pilers are clamped too tight. There has to be a small gap.
- Stuck suction cups. Remove any dirt or sediment and clean.

8.5 FEEDER HEAD PROTECTION AGAINST FEEDER DAMAGE

If the feeder head foot sensor fails, the table may keep moving upwards. In order to prevent the table from hitting the feeder head, there is a sensor under the supporting arm at the guide bar of the feeder head.

9. GATE I AND IN-FEED ROLLER MECHANISM

9.1 GATE I FUNCTION

Gate I (**h**) holds the stack of paper vertical to the front edge. If the head moves forward, the gate I turns down in order not to obstruct feeding the sheets into the machine.



h

9.2 IN-FEED ROLLER MECHANISM

The in-feed roller mechanism consists of weight rollers (a), accelerating rollers (b), upper guides (c), and sheet overlap sensor (d).

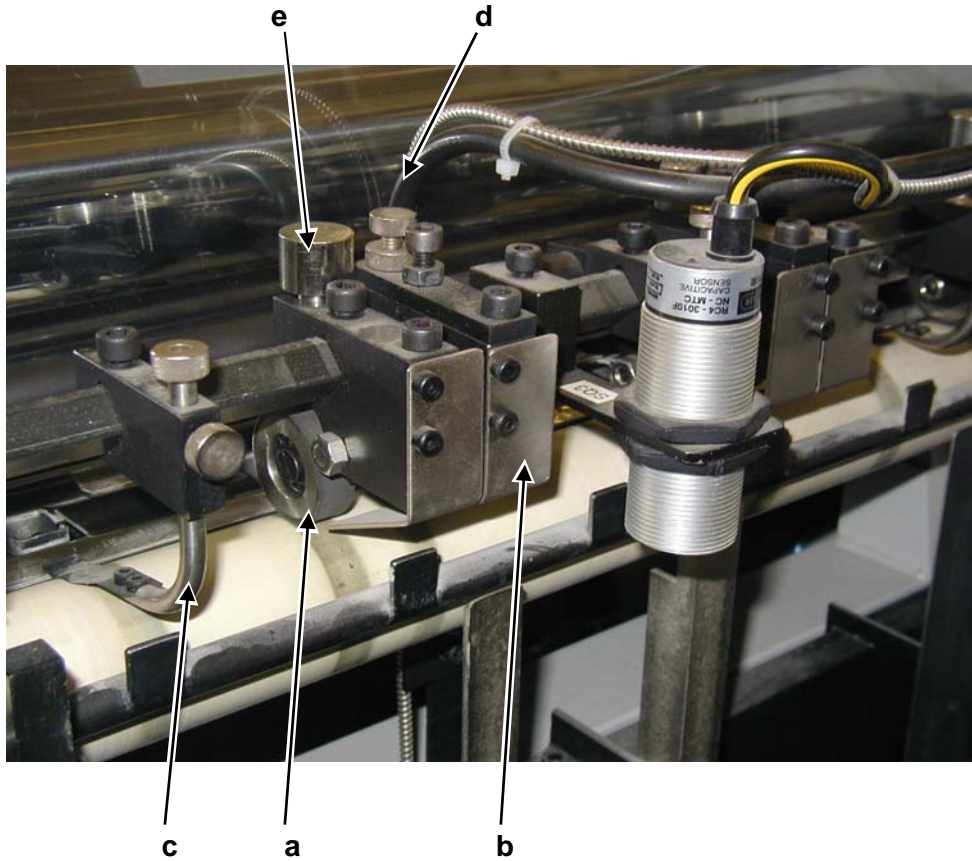

9.2.1 WEIGHT ROLLERS

The weight rollers are always in contact with the paper sheets and press them onto the in-feed roller. Their position is set by the manufacturer and should not be adjusted. If the paper weight is higher, the pressure on the loading rolls has to be increased. A set of weights (e) is provided for that purpose. The pressure can be changed by removing or adding a set of weights (e).

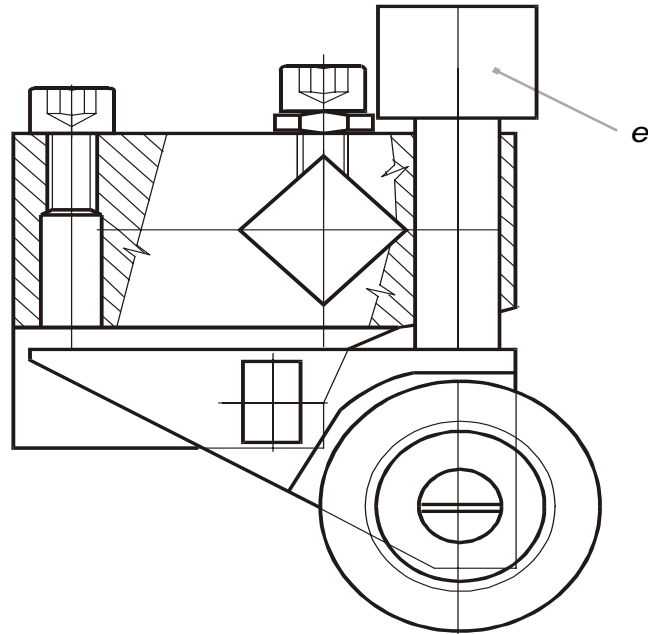

9.2.2 ACCELERATING ROLLERS

The accelerating rollers are used to increase the pressure to the in-feed roller when the gate II turns down. The mechanism is driven by the pneumatic roll on the driving side. The amount of pressure is controlled by the control system and is set by the manufacturer. The position of rollers is set by the manufacturer and the adjustment should not be changed.

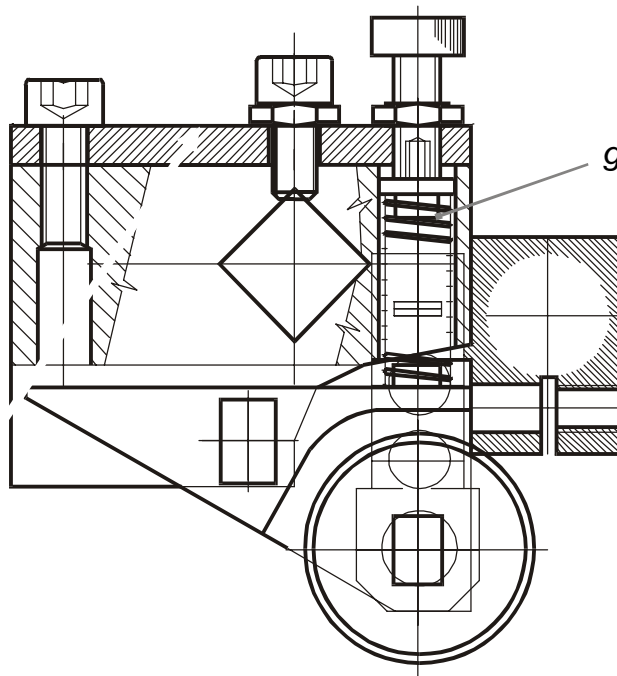

The spring (g) maintains the proper pressure.

9.2.3 upper guides

The upper guides (c) hold the paper to the bottom guide plate so that sheets will not jump over the gate II.

Position

There are three upper guides on the machine. The position of the center one is set by the manufacturer and does not change. The position of the outside holders should be changed according to the paper width. They should be adjusted so that they are approximately $13/32$ in. (10 mm) from the sheet edge. Loosen the screws (j) and then move them.

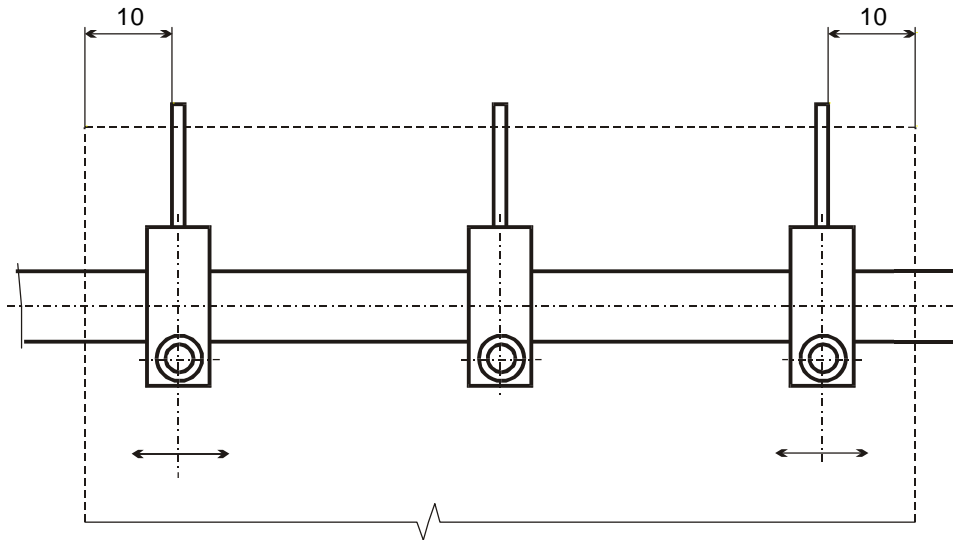

Pressure

The pressure is determined by the upper (**ch**) guide position. Refer to the following illustration. The screw (**i**) should be loosened first.

The adjustment should be done as follows:

1. Load one sheet of the paper in the machine.
2. Stop the machine when the paper is under the upper guides.
3. Loosen the screw (**i**).
4. Adjust the upper guide position so that it contacts the paper and the sheet can slide back and forth.
5. Tighten the screw (**i**).

NOTE: If a smaller size is used, move the upper guides first. Then turn the knob for moving the side guides.

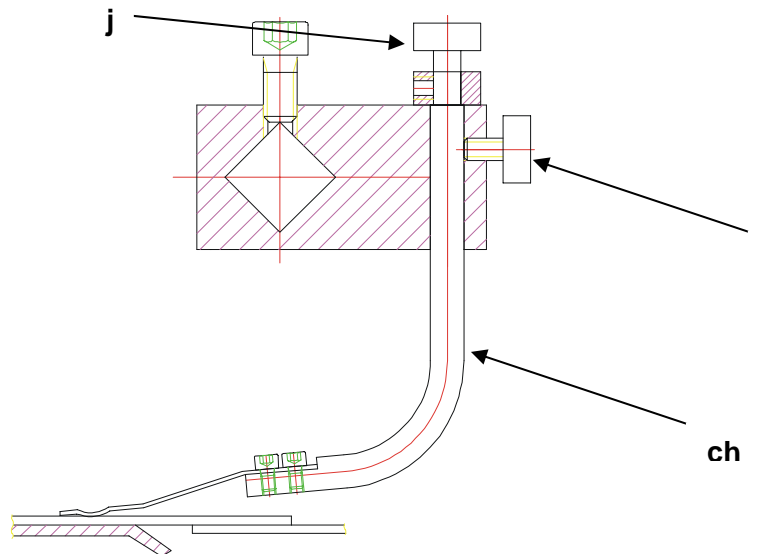

9.2.4 SHEET OVERLAP SENSOR

The sheet overlap sensor protects the supporting pressure roll and prevents the film from sticking to its surface.

Check its function daily after the machine is turned on. To do this, start the machine and put a separate sheet of paper between the receiver and sender of the SQ4 sensor. Remove the sheet. The machine should stop and the message, "Missing sheets," will display on the operator's panel.

The sensor can be repaired only by a GBC service technician.

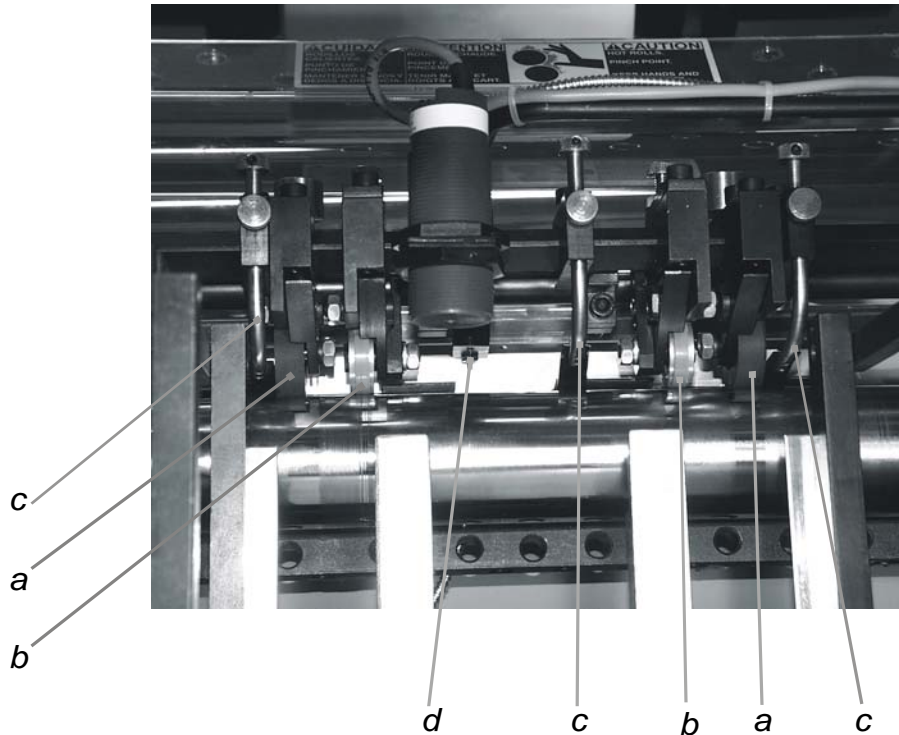

10. GATE II

The function of the gate II (a) is to hold a sheet of paper and to release it so that the overlap of the following sheets are within the tolerance of $\pm 1/16$ in. (1.5 mm).

11. ADJUSTABLE GUIDE PLATES

The guide plates (a) prevent paper from folding. The guides form the paper before the laminating roll. Their position can be adjusted by the screw (b) after loosening the nut (c). If a thicker paper is processed, the plates have to be lifted so that the sheets will not deform.

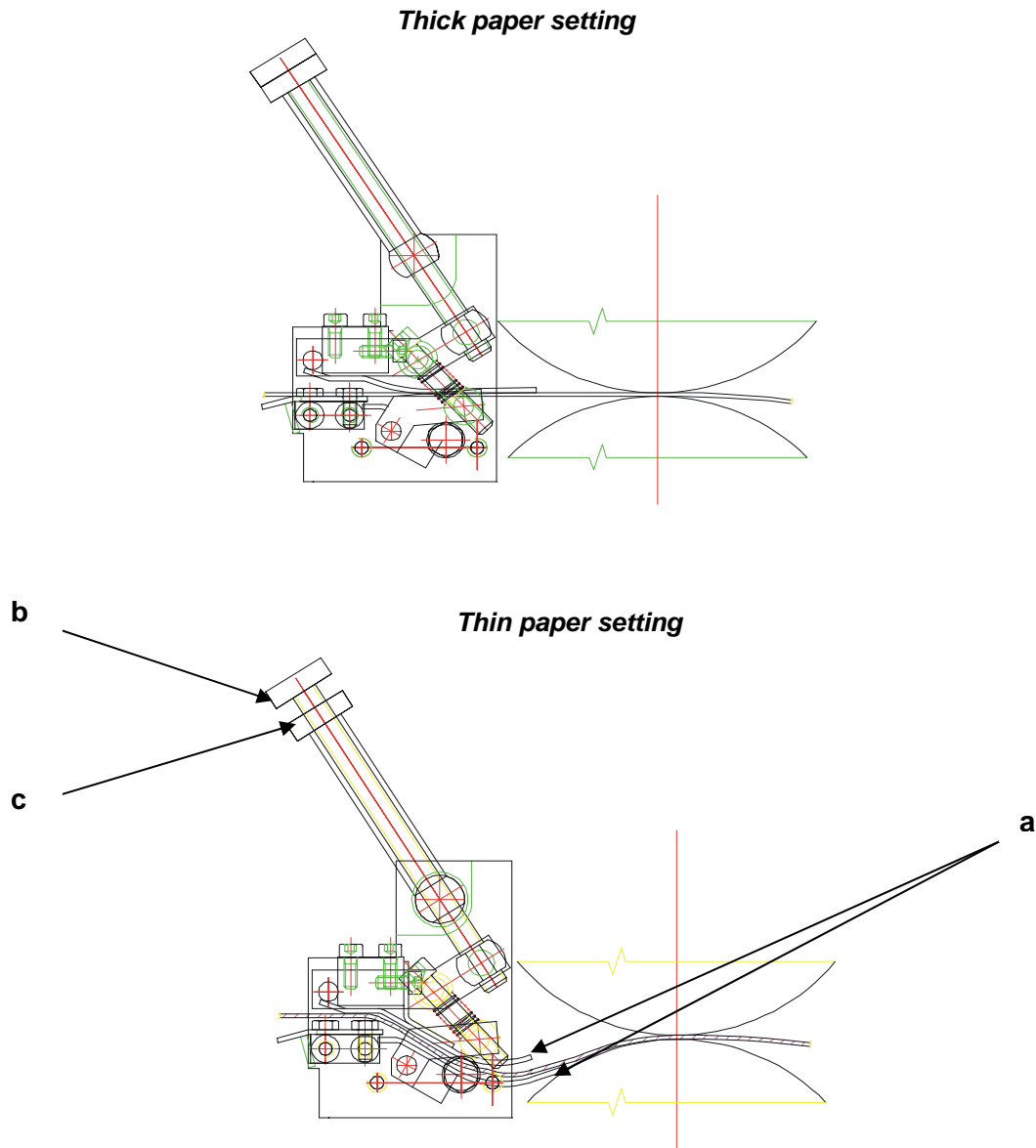

If lighter weight paper is processed, the plates have to be tipped down to reform the paper.

12. BECKER T4.25 DSK AIR COMPRESSOR

The machine is equipped with a Becker T4.25 DSK rotary wing type air compressor, which has its own documentation. The compressor works without oil.

Important

Do not position the compressor where water, oil, or any other liquids can enter the intake port.

After the compressor is connected to the machine, the first adjustment of vacuum should be set to 5.8 psi (40 kPa).

The air compressor can be turned on and off during the machine operation with the air compressor switch (a), located on the control panel.



The pressure and vacuum valve should be adjusted according to the paper size and thickness. Tightening the valve causes the air compressor to produce a maximum vacuum and pressure, which increases wear and electricity consumption.

Any air compressor function problem must be repaired only by a GBC Service technician.



CAUTION

During compressor installation, ensure that the compressor rotates in the direction of the arrow on the compressor casing. If it does not, a GBC technician must change the electric supply phase.

13. SEPARATOR

13.1 DECURLING BAR

The decurling bar straightens bent paper after laminating the film onto paper.

Position the decurling bar according to paper thickness

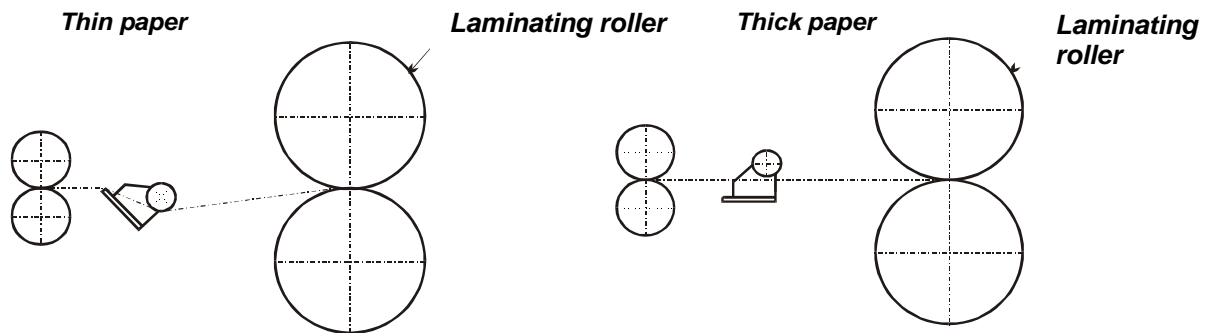

Regulating lever *Locking lever for bar turning* *Decurling bar*

SHAPE OF LAMINATING PAPER

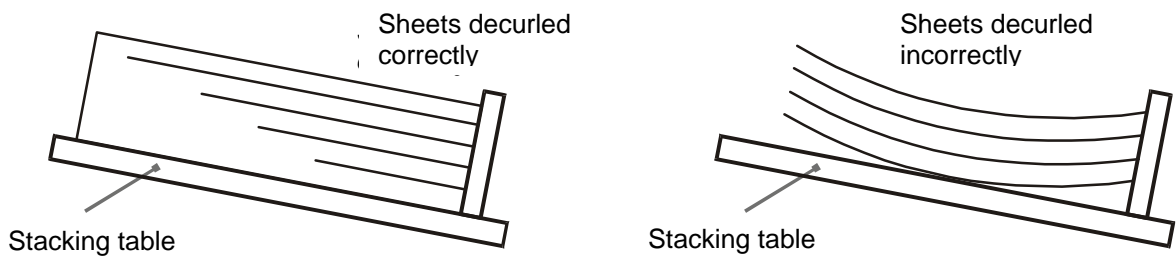

13.2 CHANGING DECURLING BAR RADIUS

If a line is apparent on the laminated sheet, radius R3 of the decurling bar (a) can be used for thin paper. The line is caused by the decurling bar edge.

To change the radius of the decurling bar:

1. Loosen the four M8 screws.
2. Turn the decurling bar (a) over end to end to the desired radius. R2 has a 5/64 in. (2 mm) radius and R3 has a 7/64 in. (3 mm) radius.

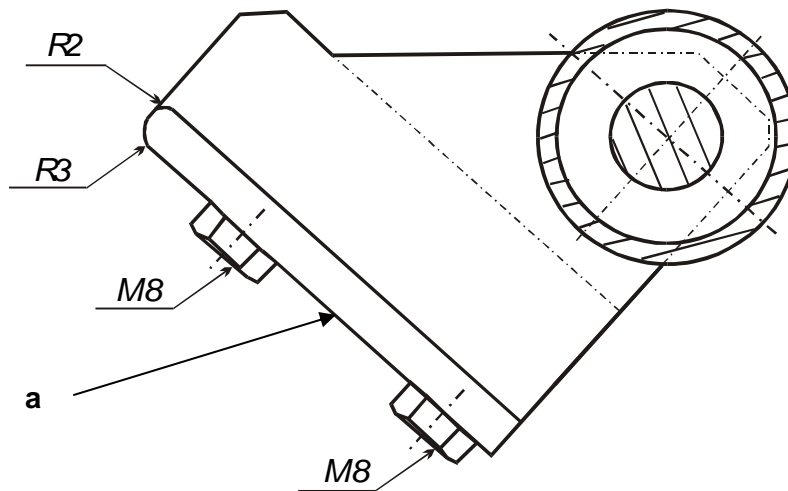

13.3 PULL ROLLERS

The pull rollers pull the paper between the laminating section and snap rolls in order to level the sheets on the decurling bar.

Regulating the paper pull

The paper pull can be changed by altering the gap between the rolls with the regulating screw. The size of the gap between the lower and upper drawing rolls is marked on the scale.

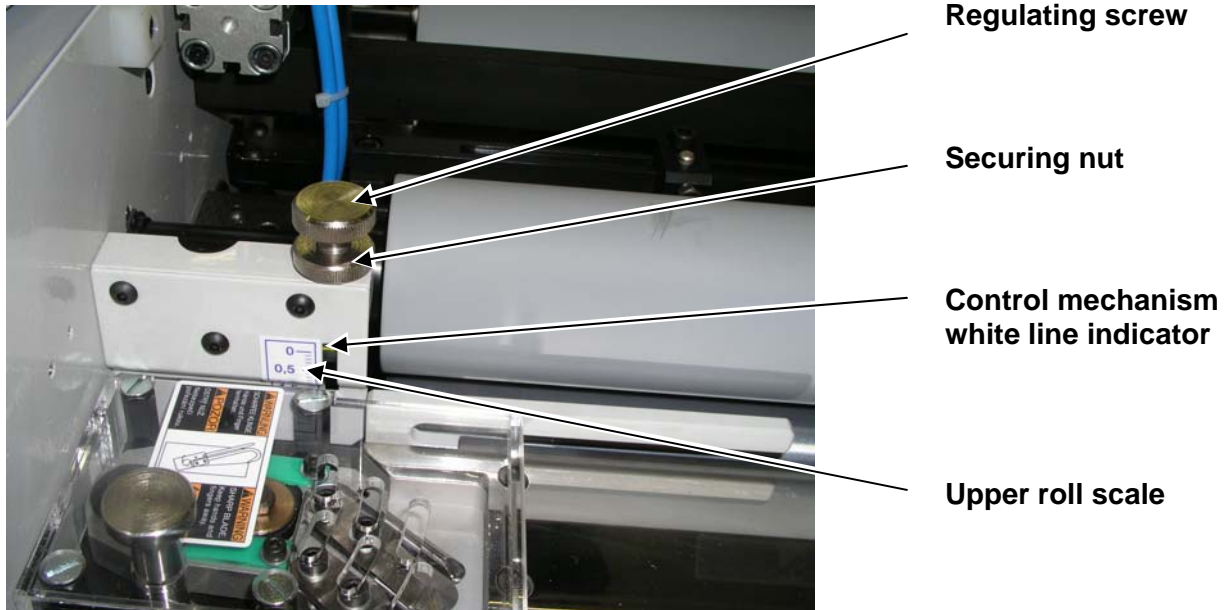

Changing the paper pull

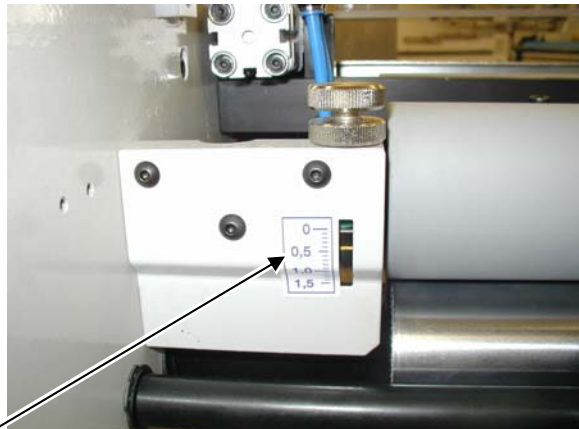

Light pull

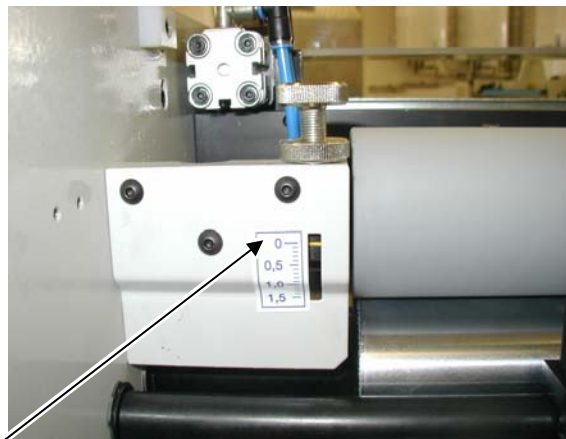
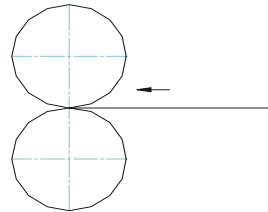
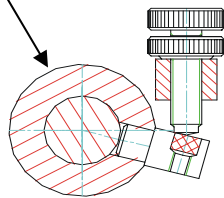

Strong pull

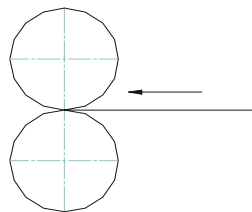
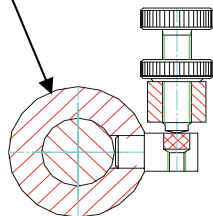

13.4 TWIN KNIVES

The continuous web of laminating film has to be nicked so that the sheets can be separated in the snapping mechanism. A knife with an oscillating motion is used for this.

Turn on the "KNIFE" switch to the "START" position to start the knives.

Position of the knife mechanism according to the paper width

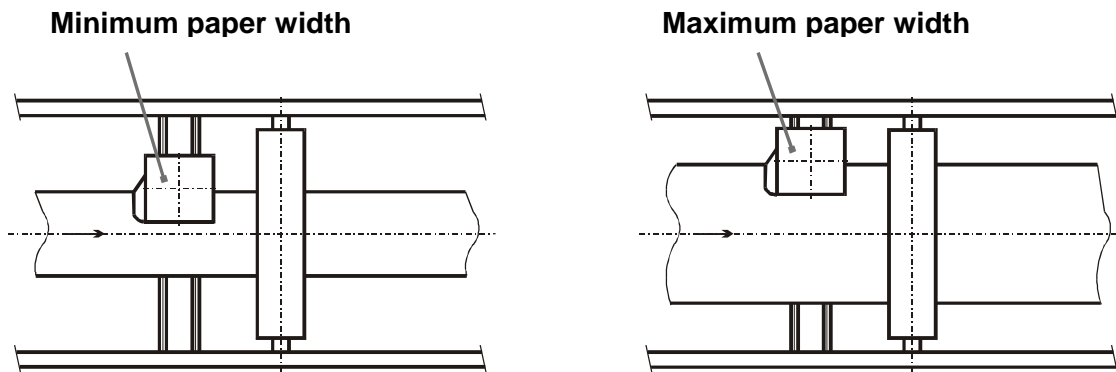

Position of the knife mechanism according to the paper's edge

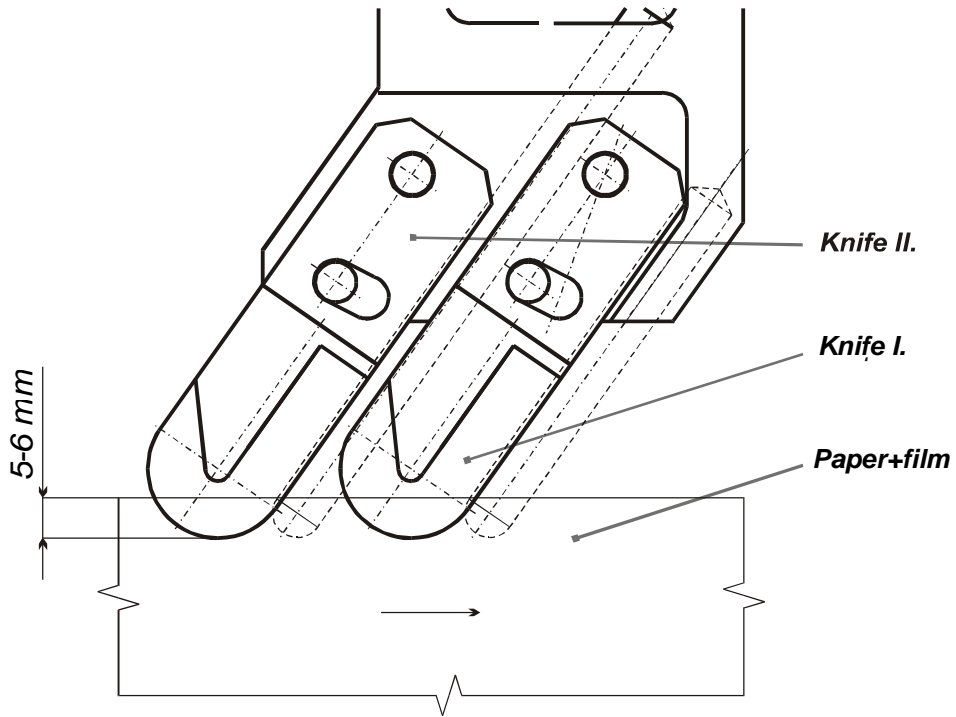

Position of the knives according to the paper thickness

Thin paper

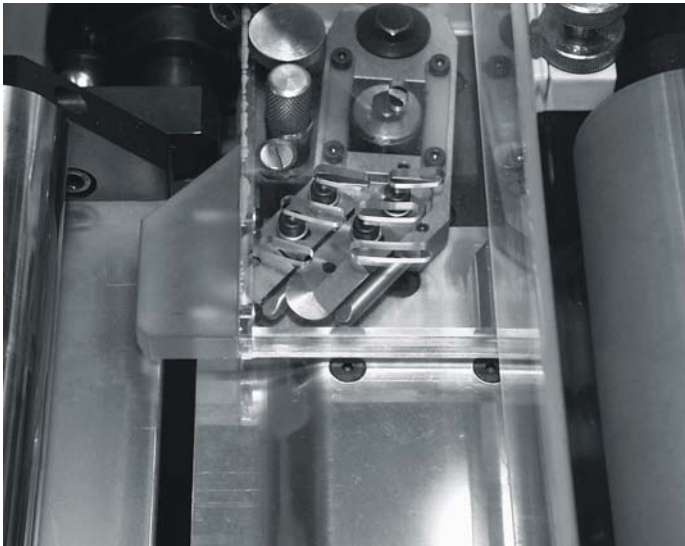
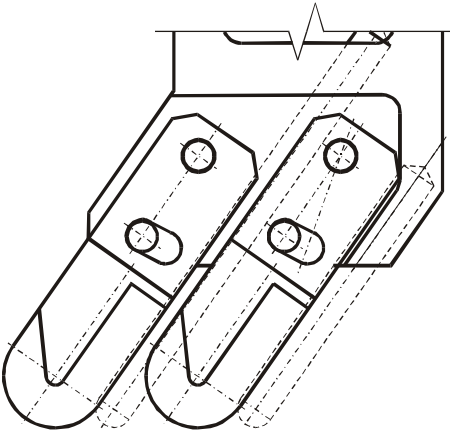

Thick paper

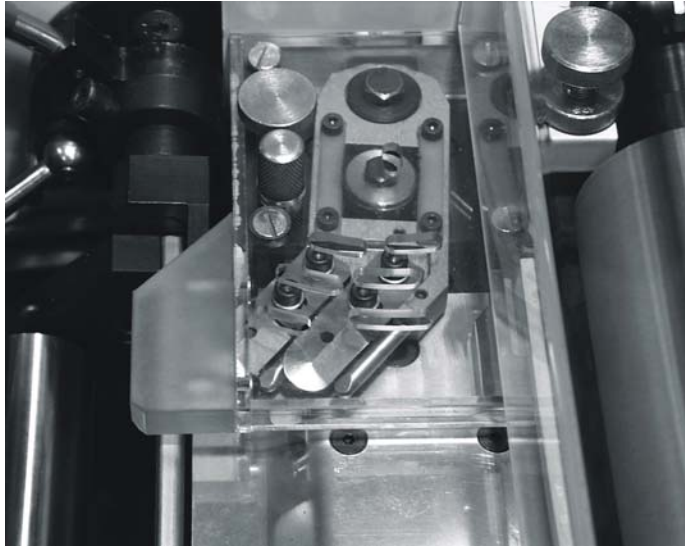
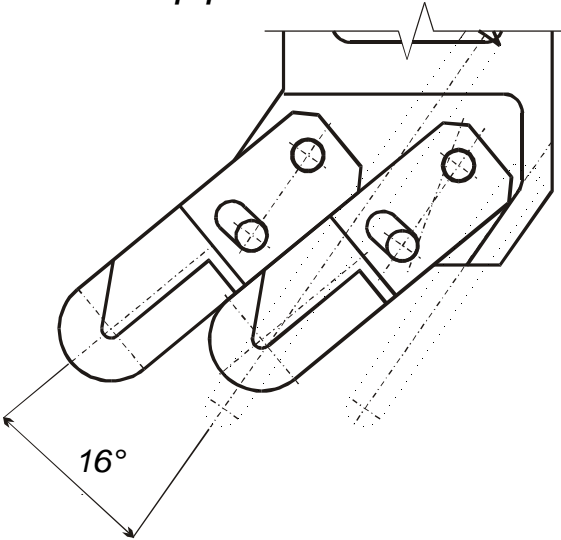

13.5 SNAPPING MECHANISM

The snapping mechanism separates the individual sheets, which are connected by the laminating film.

Controlling the upper snap roll dropping

In order to get good separation, the gap between the snapping rollers on the operator side of the rollers must close first before on the drive side of the rollers. The motion should look similar to a scissoring type of motion. Adjusting the flow controllers on the pneumatic cylinders makes this motion.

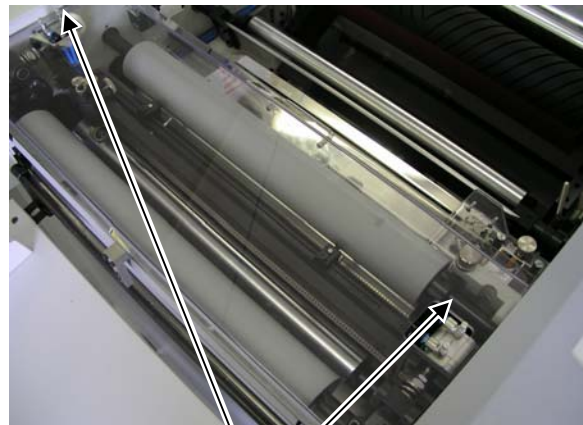
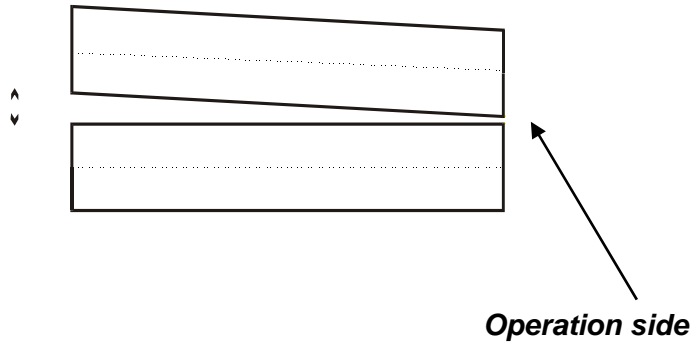

Flow controllers

Creating the paper wave in front of the snapping rollers

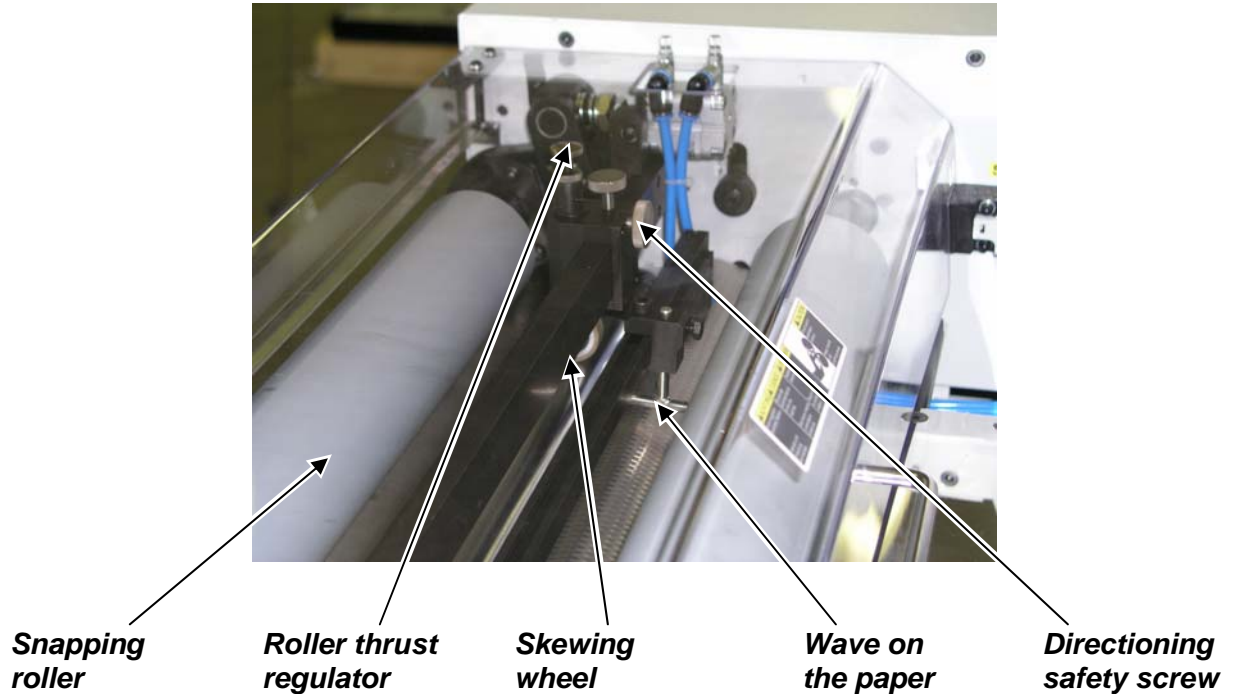

Separation of some films will improve with the use of the skewing wheel. Place the wheel on the drive side of the paper and apply just enough pressure to create a 1/2 in. (10 mm) wave in the paper just in front of the snapping rollers to separate the sheets.

The wave is made by adjusting the directioning roller on the edge of the paper band and with its directioning in the path out of the machine. (Only a mild adjustment is enough.)

Optional skewing section

An additional skewing section can be mounted behind the snapping section to make sheet separation easier for special films.

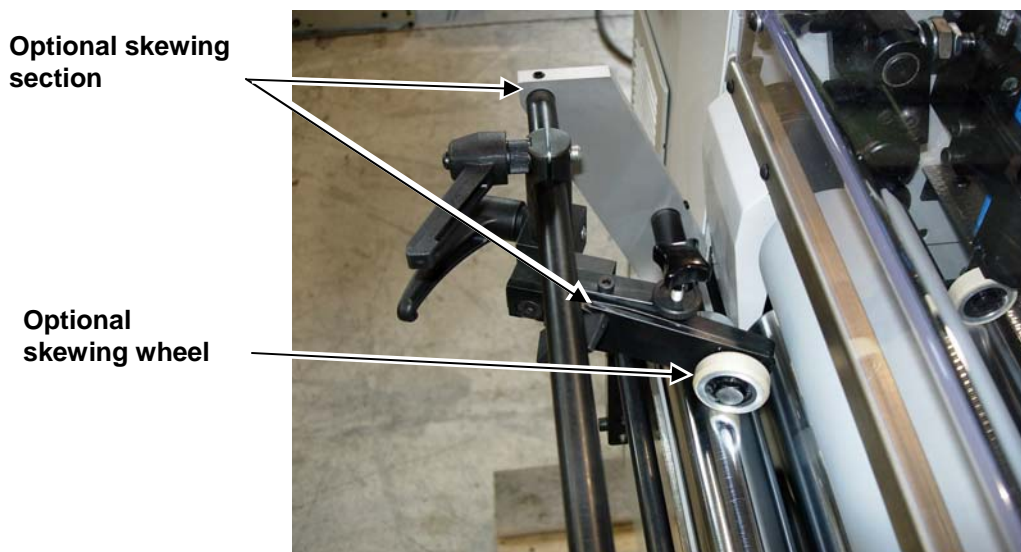

14. STACKING TABLE

14.1 STACKING TABLE DESCRIPTION

The laminated sheets, coming from the snapping section, accumulate on the stacking table.

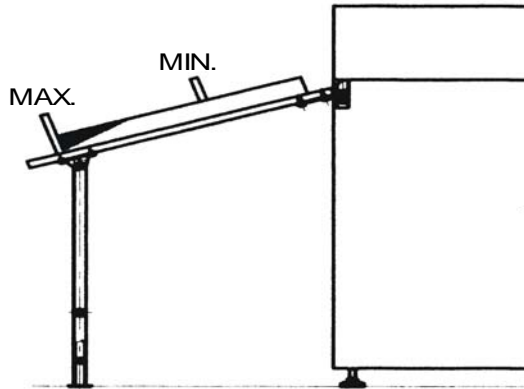

14.2 STACKING TABLE POSITION ADJUSTMENT

The stacking table position must be changed according to the selected sheet size and paper thickness. The table height can be changed at the front table clamps. To do this, remove the screw in the clamp and reposition the table as needed.

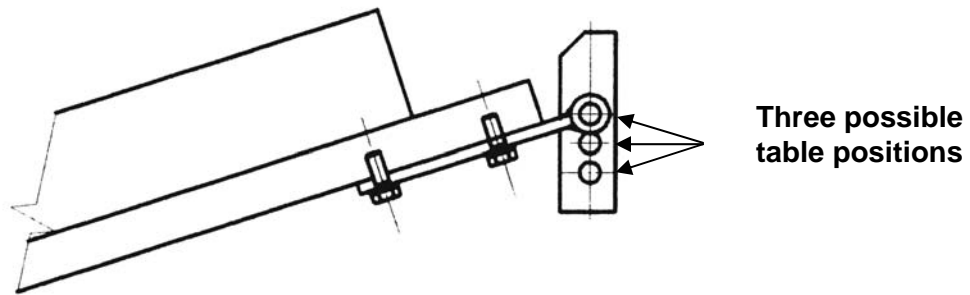

The incline angle can be also changed by adjusting the length of the legs. There are six adjustable leg positions.

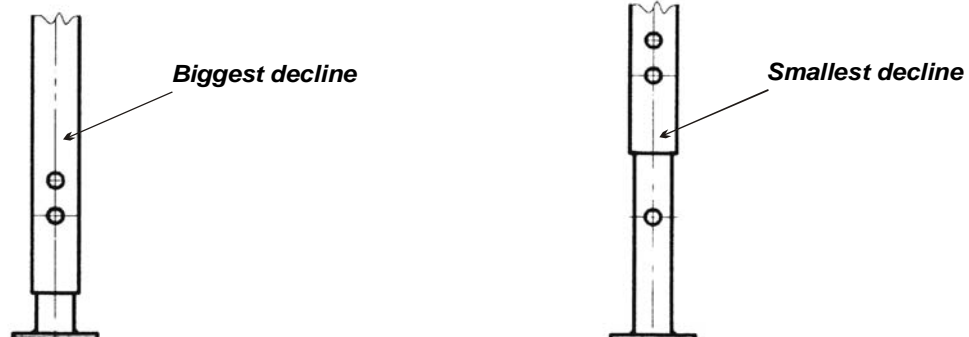

15. MACHINE TRANSPORTATION

The machine is shipped on a wooden pallet. The machine position on the pallet is shown below.

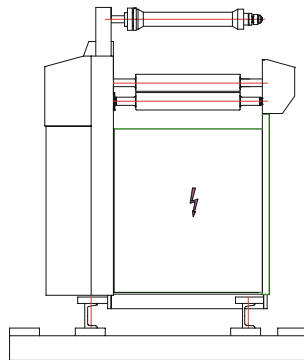

Use only a forklift or pallet truck to transport the machine. The forks must be long enough to reach past the pallet supports of the machine at the further end of the truck, as shown below.

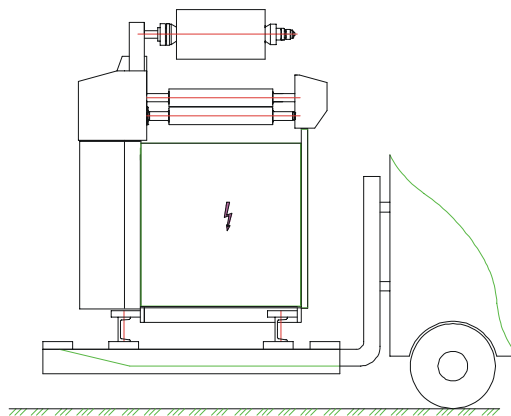

When the machine is taken off the pallet, it is necessary to:

- Unscrew the clamping screws
- Put the forks of the forklift between the pallet and machine frame

Moving the machine off the pallet to the floor is illustrated in the following illustration.

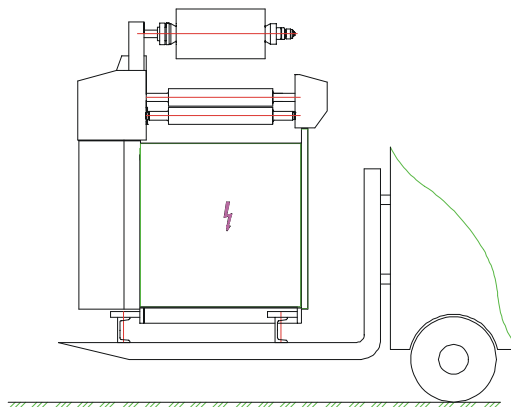

16. MACHINE INSTALLATION

A GBC service technician must install the machine, put it into operation, and train the operating personnel.

16.1 PREPARE BEFORE INSTALLATION

- Even floor with minimum bearing capacity 512 lb/ft² (25kN/m²)
- Pressure pneumatic circuit: Connection with compressed air 90 psi (0.6 MPa)

16.2 ELECTRICAL INSTALLATION REQUIREMENT

Nominal voltage	208 to 240 Vac, 60 Hz, 3 Phase plus ground
Power requirement	6.5 kVA
Nominal current	24 A
Recommended value of protection	30 A

16.3 BECKER AIR COMPRESSOR

Connect the Becker Air Compressor to the receptacle inside the machine cabinet.



CAUTION

During compressor installation, ensure that the compressor rotates in the direction of the arrow on the compressor casing. If it does not, a GBC Service technician must change the electric supply phase.

16.4 MACHINE LOCATION

The machine has to be located as follows:

- There should be a minimum gap of 16 in. (40 cm) between the stacking table and wall or other solid object.
- There should be a minimum gap of 30 in. (80 cm) between the external surface of the machine covers on the drive side and other solid objects (other machine, etc.).

16.5 FLOOR REQUIREMENTS

The machine has to stand on a solid and acceptably even floor with the bearing capacity of 512 lb/ft² (25 kN/m²)

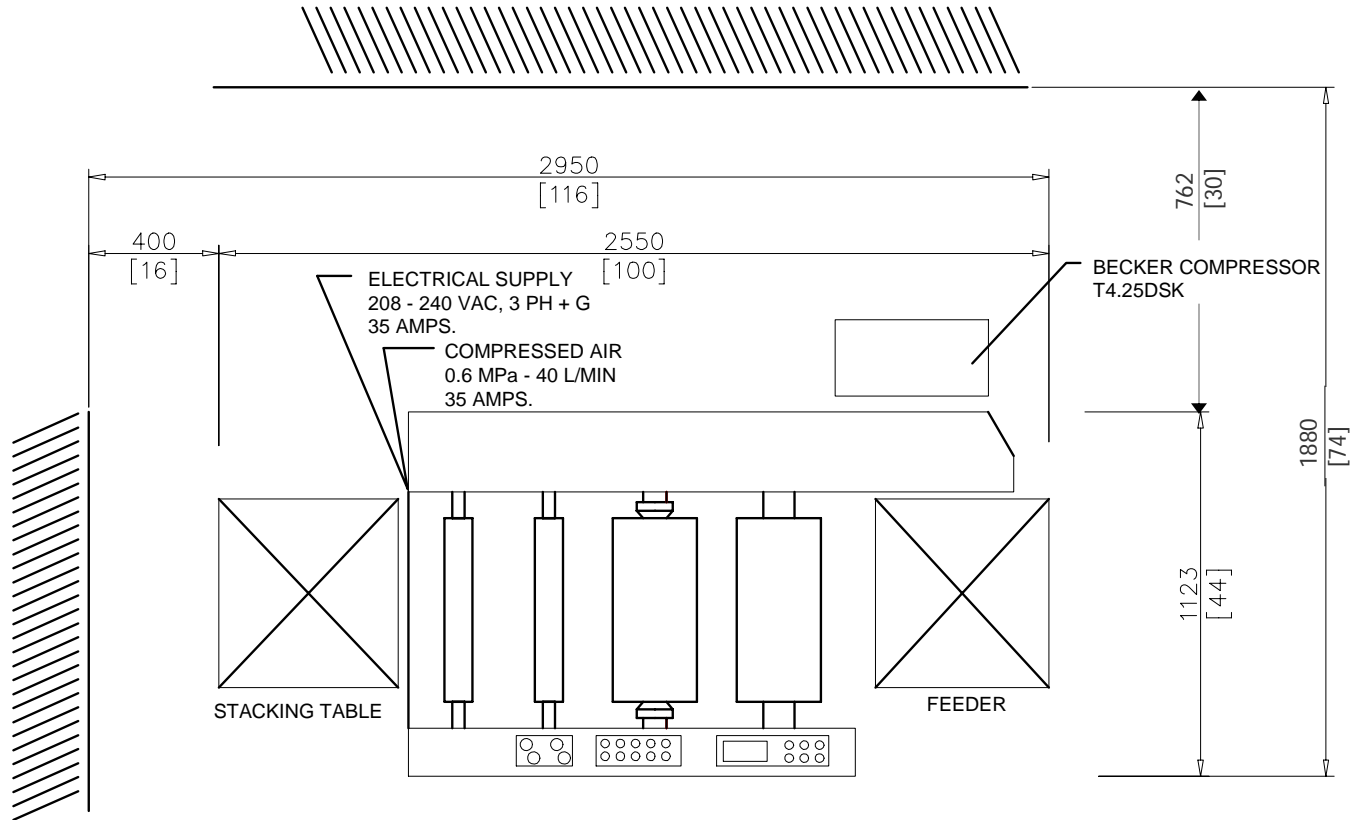

Machine installation - distance from walls, electric supply, compressed air inlet

DELTA
Laminating Machine
SERVICE MANUAL

Table of Contents

1.	SAFETY NOTICES.....	3
1.1	SAFETY NOTICES –SERVICE MAINTENANCE AND ADJUSTMENT – COMPLETE MACHINE	3
1.2	SAFETY NOTICES – FEEDER MAINTENANCE	4
1.3	SAFETY NOTICES – MAIN DRIVE MAINTENANCE.....	4
1.4	SAFETY NOTICES – CHAINS AND BELT DRIVES MAINTENANCE	5
1.5	SAFETY NOTICES – TWIN KNIFE MAINTENANCE AND CHANGE	5
2.	MECHANICAL SERVICE	7
2.1	FEEDER TABLE	7
2.2	FEEDER LIFTING MECHANISM DRIVE.....	8
2.3	STACK HEIGHT SENSOR	9
2.4	FEEDER HEAD PROTECTION SENSOR.....	10
2.5	ROTARY VALVE ADJUSTMENT	10
2.6	FEEDER HEAD DRIVE.....	11
2.7	FEEDER HEAD.....	11
2.8	GATE I.....	11
2.9	ACCELERATING ROLLERS CONTROLS	12
2.10	GATE II	14
2.11	ADJUSTABLE GUIDE PLATES	15
2.12	MACHINE MAIN DRIVE	15
2.13	PRESSURE ROLLER REPLACEMENT	16
2.14	SNAPPING ROLLER BELT	16
2.15	LUBRICATION AND INSPECTION.....	17
3.	ELECTRICAL SERVICE.....	19
3.1	TROUBLESHOOTING – MACHINE CONTROL DISPLAY	19
3.2	TROUBLESHOOTING – YELLOW ERROR LIGHT	21
3.3	TROUBLESHOOTING – PROBLEMS ARE NOT INDICATED ON THE CONTROL PANEL	31
4.	SERVICE CENTERS	33

1. SAFETY NOTICES

The safety notices in this chapter apply to the mechanical and electrical sections of this service manual.

1.1 SAFETY NOTICES –SERVICE MAINTENANCE AND ADJUSTMENT – COMPLETE MACHINE



WARNING

Obey the following precautions. Failure to do so can result in severe personal injury or damage the machine.

- Do not adjust any mechanism while the machine is in operation. The machine must be stopped, adjusted, and only then restarted.
- The machine cannot be adjusted, maintained, repaired, etc. by anyone under the influence of alcohol, drugs or some medications.
- Do not take the covers off if the machine is in operation.
- Do not start the machine with dismantled covers.
- The machine must be stopped and the switch secured before performing maintenance or adjustment.
- Do not perform maintenance on the machine if the temperature of the laminating roller surface exceeds 122 °F (50°C).
- The laminating roller temperature can be checked by:
 - The temperature value on the control panel temperature regulator
 - With an external temperature measuring instrumentIf the temperature of the laminating roller surface according to of the above point cannot be assured, maintenance or adjustment cannot be performed until 60 minutes after the roller heater has been turned off.
- Do not wear loose fitting clothes while you perform maintenance or adjust the machine.
- Use proper tools for maintenance and adjustment. Improper tools may cause injury.
- Use the eye protective shield while putting on springs.
- Maintenance and adjustment can be done only by a technician trained by GBC Service.

1.2 SAFETY NOTICES – FEEDER MAINTENANCE

In the automatic operation the feeder table moves upwards in steps. When a new paper stack is loaded, the table moves both upwards and downwards. To assure safe work, the following rules must be observed.

Important

- The feeder lifting mechanism can be adjusted and greased only by a trained and responsible person.
- Use the "STACK UP" and "STACK DOWN" buttons only for moving the table up and down.
- Grease the feeder head mechanisms only when the machine is stopped.



1.3 SAFETY NOTICES – MAIN DRIVE MAINTENANCE

The main motor drives, the feeder head, in-feed wheels, gate II, laminating roller, and drive mechanisms are located opposite the operator's side and are covered with a sheet metal cover. To assure safe work, the following rules have to be observed.



WARNING

Obey the following precautions. Failure to do so can result in severe personal injury or damage the machine.

- Cut the compressed air supply off to adjust the gate II and pressure roller mechanisms.
- The main drive mechanism can be adjusted by a trained person only.

1.4 SAFETY NOTICES – CHAINS AND BELT DRIVES MAINTENANCE

The chain and belt drives are located under a sheet metal cover, opposite the operator's side.



WARNING

Obey the following precautions. Failure to do so can result in severe personal injury or damage the machine.

- The power switch must be in the OFF (O) position while tightening the chain or belt. All other activities must be provided by GBC service.

Important

- As far as maintenance is concerned, the chain lubrication and chain tightening are the only allowed maintenance operations. Other maintenance and repair activities have to be provided by GBC service.

1.5 SAFETY NOTICES – TWIN KNIFE MAINTENANCE AND CHANGE

The twin knife has a very sharp edge and therefore the following safety rules have to be observed.



WARNING

Obey the following precautions. Failure to do so can result in severe personal injury or damage the machine.

- Use a 4 mm Allen wrench to adjust the knife position. The wrench can be put through the oval holes at the upper part of the Plexiglas cover of the twin knife.
- Do not touch the sharp edges of the knives during adjustment or changing of the knives. The knives can be held only away from the sharp edges.
- When handling the knives, put them in a safe place outside of the machine where no one can get injured.

The solid safety Plexiglas cover must be installed every time when new or original knives are tested or adjusted.

2. MECHANICAL SERVICE

2.1 FEEDER TABLE

The feeder table is suspended on two roller chains and guided on two guide bars. Only a technician trained by GBC Service can change or tighten the roller chains.

2.1.1 Chain Tension Adjustment

- The solid safety covers do not have to be removed for tightening the chains.
- Tighten the chains using the tightening screws on the feeder frame.

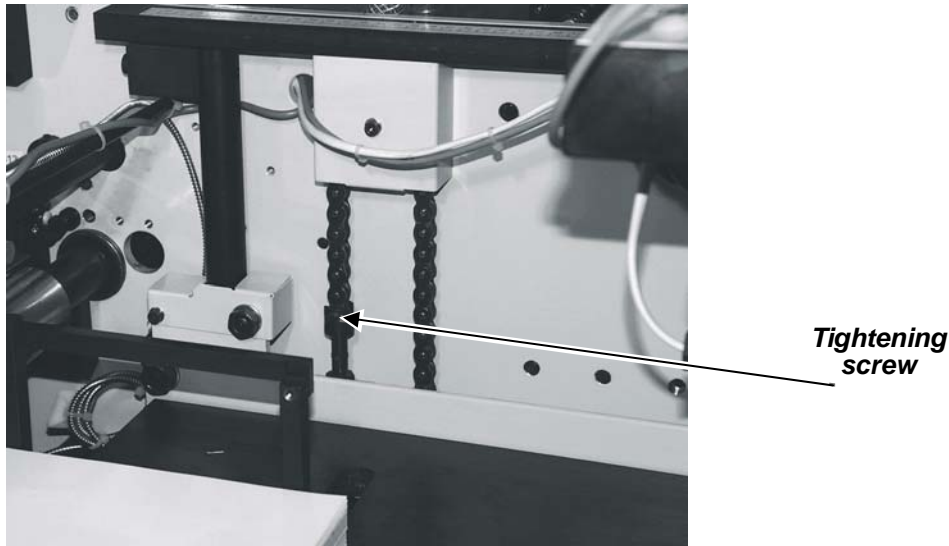

2.1.2 Chain Replacement

1. Disassemble the sheet metal safety covers.
2. Disconnect the chain from the tightening screws.
3. Take the old chain off.
4. Put a new chain on.
5. Connect the chain to the tightening screws and tighten the chains so that the table will go up evenly in the horizontal position.
6. Install the sheet metal safety covers.

2.1.3 FEEDER TABLE TROUBLESHOOTING

- **The feeder table moves uneasily although a stack is not loaded.**
Check the tightness of the chains or tighten the chains properly. Clean or oil the guide strips.
- **The automatic feeder table lifting is not working reliably.**
The problem can be removed only by a GBC Service technician. Maintenance consists of regular lubrication of the functional parts according to the lubrication plan and removal of the excess grease and dust.

2.2 FEEDER LIFTING MECHANISM DRIVE

The feeder table is suspended on the roller chains (**h**) and driven by the electric motor with a gearbox (**j**). The chain is clamped to the table on both sides. The torque from the motor is transferred through the drive shaft on both sides of the lifting mechanism, which eliminates binding.

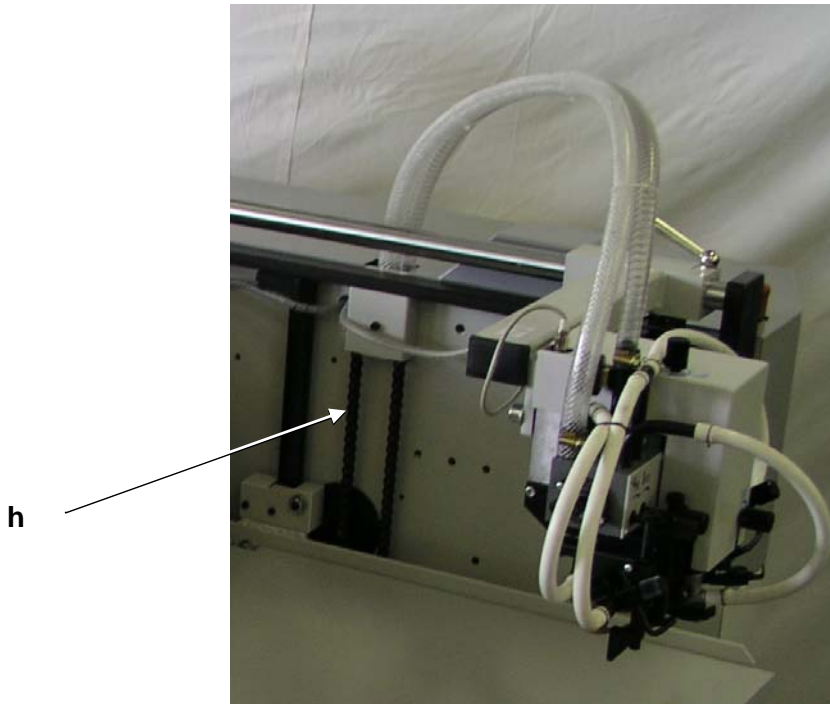

2.3 STACK HEIGHT SENSOR

The stack height sensor has to stop the paper stack 5/32 to 15/64 in. (4 to 6 mm) from the top of the gate I.

The position of the paper stack when it stops is adjustable with a small screw on the top of the capacity sensor (**g**). The capacity sensor can be adjusted only by a technician trained by GBC Service.

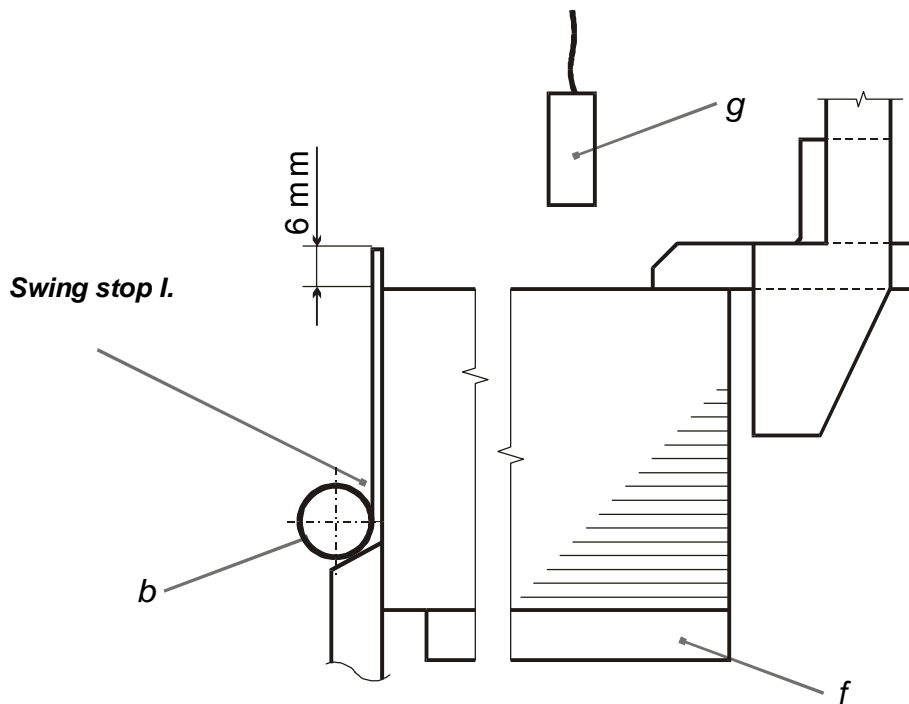

2.4 FEEDER HEAD PROTECTION SENSOR

The feeder head is protected by a sensor from damage in the case of:

- The feeder head foot slides from the paper stack and the feeder table automatically rises up.
- The capacity sensor on the front of the paper stack fails.

The sensor is located under the feeder head and is close to the clamp.

If the sensor stops the machine for one of the reasons described above, do the following:

1. Switch the power off with the main power switch.
2. Remove 1 to 1-1/2 in. (25 to 35 mm) of paper from the top of the paper stack.
3. Check to see what caused the machine to stop.

The above procedure can be performed only by a technician trained by GBC Service.

If the sensor must be adjusted so that it will not prevent the normal function of the feeder head and will stop the table movement just when the feeder head is slightly lifted around the guide bar after the feeder (stack) hits the feeder head, the adjustment can be performed only by a GBC Service technician.

2.5 ROTARY VALVE ADJUSTMENT

For correct feeding, it is necessary to precisely adjust the paper release from the suction cups. The adjustment should be performed by turning the rotary valve (**p**). The release moment has to be 1/16 to 5/64 in. (1.5 to 2 mm) in front of the front dead center of the suction cup motion. The correct position of the rotary valve is adjusted by the manufacturer and it is marked by a screwed hole in the hollow.

The adjustment can be performed only by a GBC Service technician.

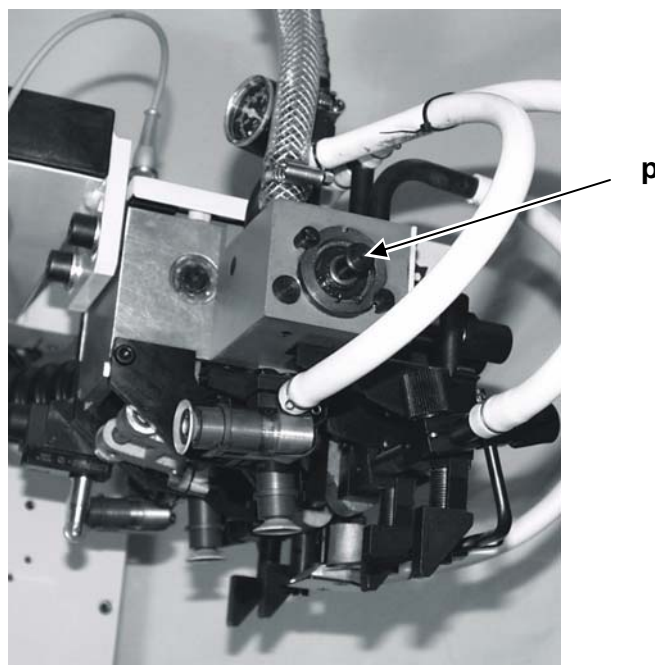

2.6 FEEDER HEAD DRIVE

The feeder head drive consists of the main motor (**q**) and the variator (**r**). The torque is transferred to the head by the cardan shaft (**s**). Any adjustment can be done only by a GBC Service technician.

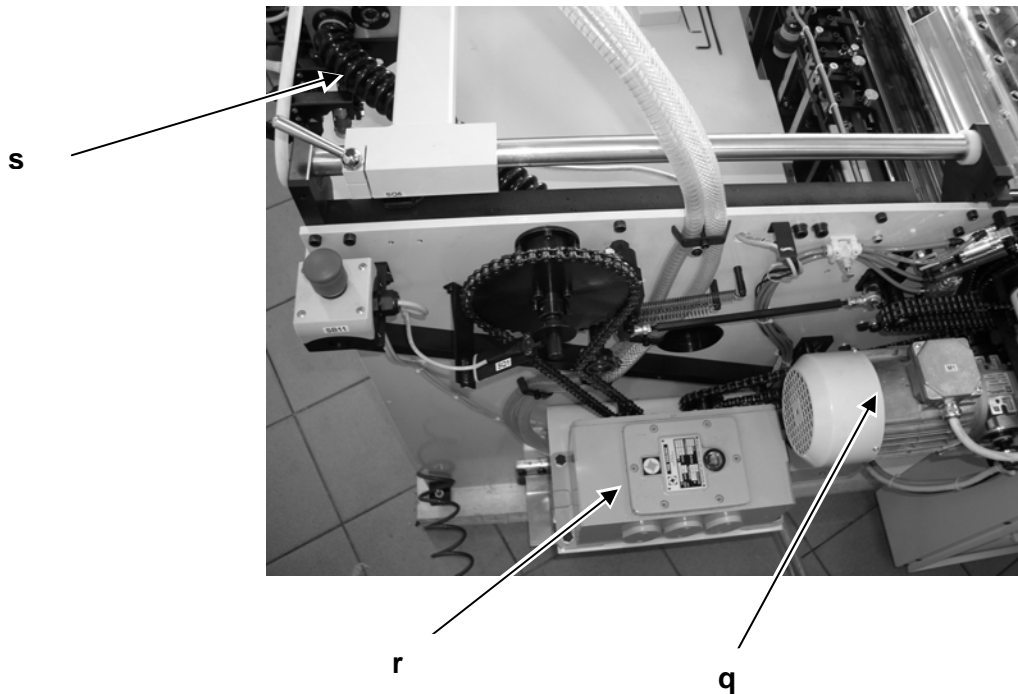

2.7 FEEDER HEAD

All adjustments and repair of the feeder head can be performed only by a GBC Service technician.

2.8 GATE I

Assembly and disassembly can be performed only by a service technician.

2.9 ACCELERATING ROLLERS CONTROLS

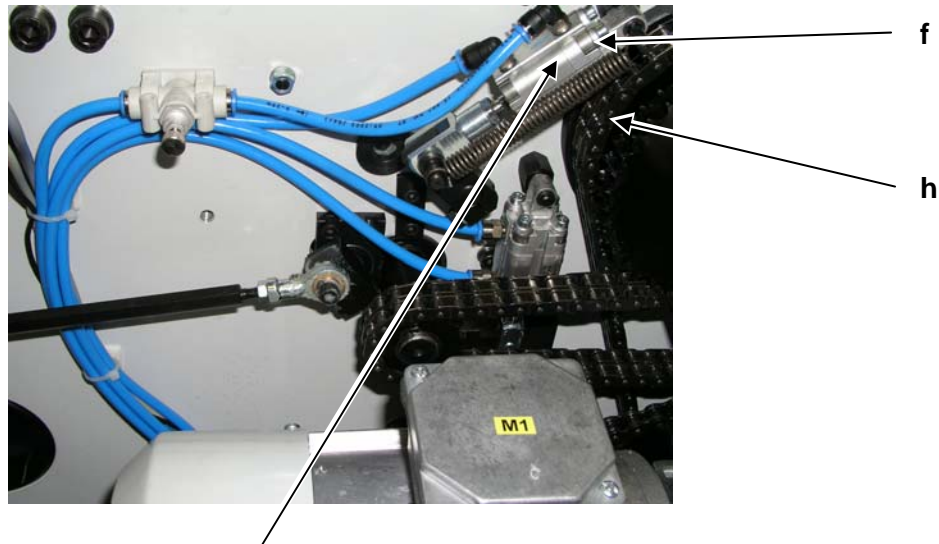

Pneumatic cylinder controlling the accelerating roller

A section view of the accelerating rollers controls is shown below.

Maintenance should be performed as follows:

1. Disassemble the sheet metal safety cover.
2. Change the defective components.
3. Install the sheet metal safety cover.

The mechanism is driven by the pneumatic cylinder (f) on the driving side. The gate II mechanism is controlled by the control system and is set by the manufacturer. The position of rollers is set by the manufacturer and the adjustment should not be changed.

If the compressed air is cut off to the pneumatic roll (f), the spring (h) retracts the pressing roller so that it does not contact and deform the feeding roller. Ensure that the spring is in good working order.

Only a technician trained by a GBC Service technician can change the pneumatic cylinders or electromagnetic valves.

The accelerating roller assembly details are shown below.

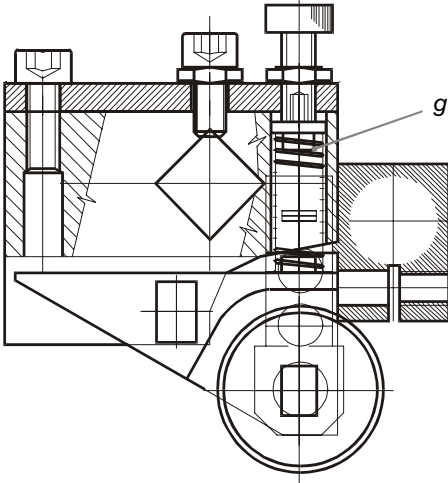

2.10 GATE II

2.10.1 Gate II Control Mechanism

Gate II is controlled from the pneumatic cylinder (b), which turns the lever (c) and therefore the whole bar with the gate (a).

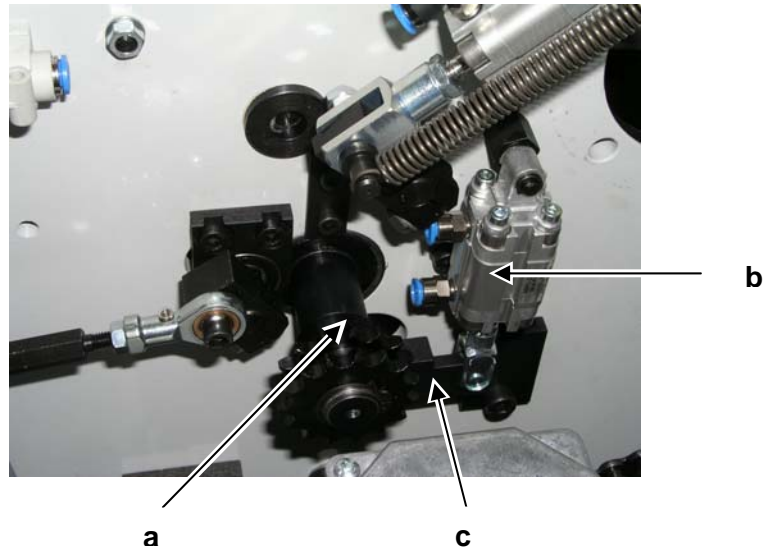

2.10.2 GATE II POSITION

The upper edge of the gate II must exceed the guide plate by $\frac{3}{32}$ to $\frac{7}{64}$ in. (2.3 to 2.7 mm). The position is set by the manufacturer and can be adjusted only by a GBC Service technician.

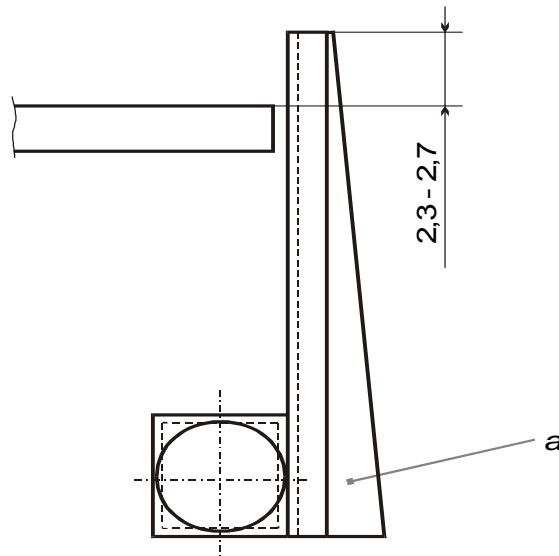

2.11 ADJUSTABLE GUIDE PLATES

Assembly and disassembly can be performed only by a GBC Service technician.

2.12 MACHINE MAIN DRIVE

The main drive roller chains are located under the sheet metal safety cover on the opposite side of the operator.

Only a technician trained by a GBC Service technician can change or tighten the roller chains.

Maintenance should be performed as follows:

1. Disassemble the sheet metal safety cover.
2. Check the chains.
3. Tighten or adjust the chain, or change the spring.
4. Install the sheet metal safety cover.

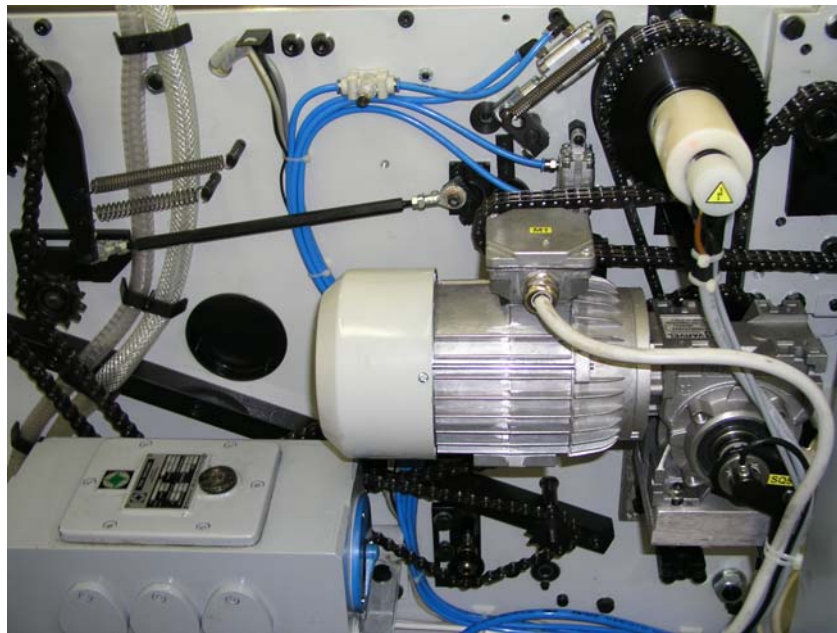

2.13 PRESSURE ROLLER REPLACEMENT

2.13.1 Pressure roll disassembly and assembly

The following should be performed by two people. To reassemble the pressure roll, reverse the steps.

1. Put two 1/2 x 2 in. x 4 ft. (10 x 50 mm x 1.2 m) bars under the pressure roller.
2. Disconnect the pneumatic cylinder pins from the pressure roller arms.
3. Unscrew the two pressure roller arm pivots from both arms of the pressure roller.
4. Roll the pressure roller with the arms from the front position to the gap between the laminator and separator, and take them out of the machine.

2.14 SNAPPING ROLLER BELT

Assembly and disassembly can be performed only by a technician trained by a GBC Service technician. If a belt fails, it must be changed. The proper belt type is given in the parts catalog and it is also printed on the upper surface of the belt. All the tighteners need to be loosened when the belts are changed.

2.15 LUBRICATION AND INSPECTION

It is necessary to lubricate and inspect the different parts regularly in order to prolong the machine function and life.

Weekly:

- Check the condensate quantity in the air treatment unit. If the condensate level in the container exceeds 15/64" (20 mm), let some condensate out.
- Check if the covers are installed and all screws secured
- Check the correct function of sensors
- Feeder limit switches
- Capacity indicator
- Feeding head protection Indicator
- Movable covers inspection indicators
- Emergency stop button

Every 14 days:

- Clean all sliding leads and lead bars and then lubricate with liquid oil or spray.
- Clean the cam and lubricate with grease.
- Clean the guide pulleys and lubricate with grease.

Monthly:

- Check and lubricate all roller chains with grease

The main drive and feeder lifting gearboxes:

Running-in 300 hours – do not load with the maximum power output

The MRT gearboxes are filled in with long-life synthetic oil, class ISO VG 320. The gearboxes are not equipped with filling, drain, or level indicator bolts.

Main drive MRT 50	4 oz. (0.13 liters) of oil
Feeder lifting MTA 63/50	1 + 4 oz. (0.04 + 0.13 liters) of oil

If it is necessary to change or add the oil, use the same type of oil only. Never use mineral oil.

Mechanical Variator:

Running-in	10,000 hours, oil OTK-8÷10
Regular operation	10,000 hours, oil OTK-8÷10

3. ELECTRICAL SERVICE

3.1 TROUBLESHOOTING – MACHINE CONTROL DISPLAY

3.1.1 Service Screen No. 1 – Pneumatic Cylinders

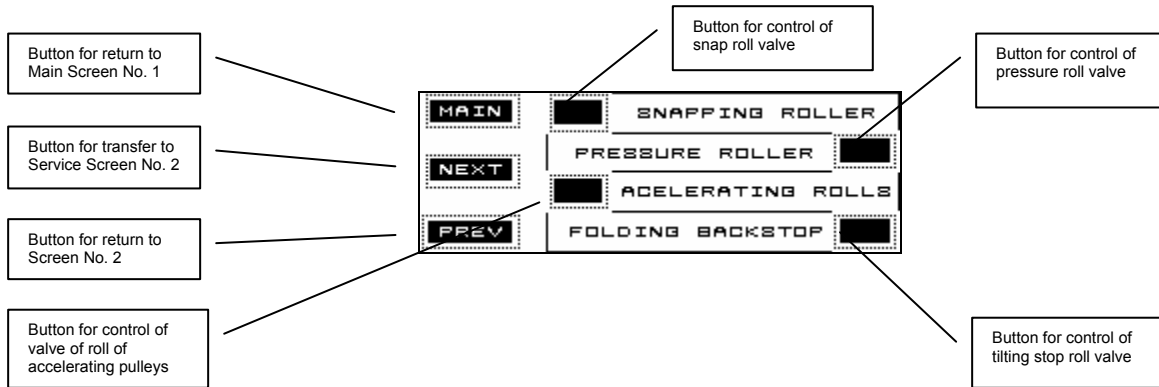

Note:

All buttons in this screen work on the principle of "OFF/ON," except for the snap roll button, where a pulse for the snap roll valve is generated by pressing this button.

3.1.2 Service Screen No. 2

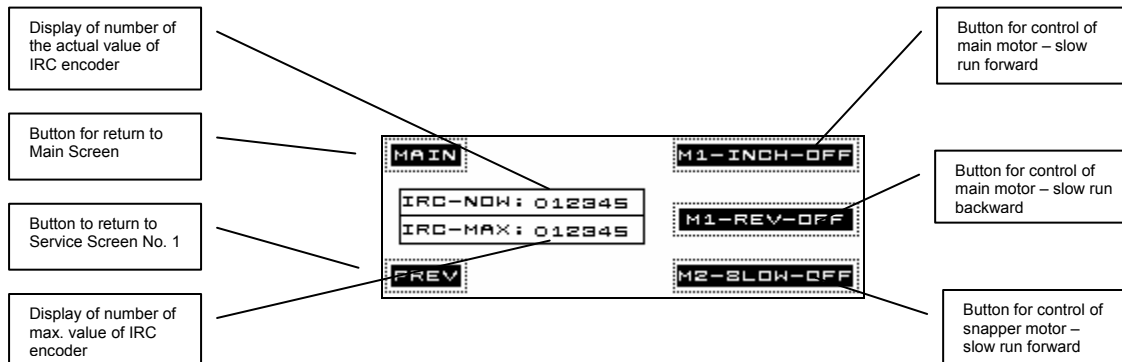

Note:

All buttons in this screen work on the principle of "running while the button is pressed."



WARNING

These buttons should only be used by service technicians for machine adjustment and for testing the function of M1 and M2 motors. Do not use these buttons in any other way.

The displayed number of the actual value of the IRC encoder is used for visual control of the correct function of this element. During the machine operation (the main motor is turning) it adds the number up to the maximum value, then it resets and the action repeats.

The maximum number of the IRC encoder is the maximum caught number, which is proportional to the paper format. This number will reset by switching the “SNAP IMPULSE” button off. It means that if the format is changed to a smaller one, it is necessary to switch the “SNAP IMPULSE” button off and thus the number will reset.

3.2 TROUBLESHOOTING – YELLOW ERROR LIGHT

The machine error is signaled by yellow indicator ERROR (lit up continuously or blinking) and the error/status message on the operator's panel in the right at the top. By touching this part of the panel, you get to the Error Screen where the error/status is described in detail.

3.2.1 Error – incorrect sequence of phases

Status indication:

- Operator's panel, Main screen, 1st status line: ERROR
- Operator's panel, Main Screen, 2nd status line: Phase sequence
- Error Screen:
 - Bad phase sequence
 - of power supply

Status correction:

- Switch the machine off.
- Change the sequence of the phases on the machine supply unit.
- Switch the machine on.

3.2.2 Status – the safety relay is not active

Status indication:

- START button/indicator is blinking with short flashes
- Yellow ERROR indicator is blinking with short flashes
- Operator's panel, Main Screen, 1st status line: STATUS
- Operator's panel, Main Screen, 2nd status line: Safety relay
- Error Screen:
 - Safety relay is not active
 - Check emergency stop
 - Close covers
 - Press button START

Status correction:

- Check the switching position of both emergency stop buttons.
- Close all the machine covers.
- Switch on the safety relay by pressing buttons START.
- If the safety relay cannot be switched on by pressing button START even after the previous steps, there must be an error the electrical connection (for example a loose conductor). See wiring diagram DA-41-100n, Sheet 4.

3.2.3 Error – fuse FU11 is broken

Status indication:

- Yellow ERROR indicator is lit up continuously.
- Operator's panel, Main Screen, 1st status line: ERROR
- Operator's panel, Main Screen, 2nd status line: Fuse FU11
- Error Screen:
 - Fuse FU11 is broken
 - or disconnected wire
 - Change fuse
 - or check wiring

Status correction:

- Check fuse FU11 in the switchboard and if it is broken, replace it.
- If the fuse is not broken, check the connection. See DA-41-100n. sheet 2
- The electrical potential on conductor No. 217 at input PLC X35 must reach the voltage of 24 Vdc (See DA-41-100n, sheet 7)

3.2.4 Error – space between sheets

Status indication:

- START button/indicator is blinking.
- Yellow ERROR indicator is blinking.
- Operator's panel, Main Screen, 1st status line: ERROR
- Operator's panel, Main Screen, 2nd status line: Missing sheets
- Error Screen:
 - Space between sheets
 - Correct overlap of paper
 - Press button START or STOP
 - or Feeder UP or Feeder DOWN

Status correction:

- Check the space between the sheets.
- Prevent sticking the foil to the pressure roll.
- Quit the error by pressing buttons STOP, FEEDER UP, FEEDER DOWN
- Start the machine by pressing button START.

3.2.5 Error - protection of the loading head

Status indication:

- Yellow ERROR indicator is lit up continuously.
- Operator's panel, Main Screen, 1st status line: ERROR
- Operator's panel, Main Screen, 2nd status line: Protect. head
- Error Screen:
 - Protection loading head
 - Press button Feeder DOWN

Status correction:

- Check the position of the head and if it is deflected by the stack of paper sheets, loosen the stack.
- Move the loading table down and quit the error by pressing the “FEEDER DOWN” button
- Check the connection on the branch of the loading head protective sensor (SQ6) according to the wiring diagram (See DA-41-400n, sheet 5)

3.2.6 Error – instrumentation of circuit breaker FA1 for frequency inverter U1

Status indication:

- Yellow ERROR indicator is lit up continuously.
- Operator's panel, Main Screen, 1st status line: ERROR
- Operator's panel, Main Screen, 2nd status line: Circuit Breaker
- Error Screen:
 - Circuit breaker
 - Check circuit breaker
 - and switch ON

Status correction:

- Check circuit breaker FA1 in the switchboard.
- Turn the circuit breaker to position I.
- If the error is still reported on the operator's panel, it is necessary to check the connection of conductors 217 and 711, which lead to input PLC X37 (See DA-41-100n, sheet 7).

3.2.7 Error - fuse FU12 is broken

Status indication:

- Yellow ERROR indicator is lit up continuously.
- Operator's panel, Main Screen, 1st status line: ERROR
- Operator's panel, Main Screen, 2nd status line: Fuse FU12
- Error Screen:
 - Fuse FU12 is broken
 - or disconnected wire
 - Change fuse
 - or check wiring

Status correction:

- Check fuse FU12 in the switchboard and if it is broken, replace it.
- If the fuse is not broken, check the connection. See DA-41-100n, sheet 2
- The electrical potential on conductor No. 218 at input PLC X36 must reach the voltage of 24 Vdc (See DA-41-100n sheet 7).

3.2.8 Error on IRC of encoder SQ5 or of the main drive

Status indication:

- START button/indicator is blinking.
- Yellow ERROR indicator is lit up continuously.
- Operator's panel, Main Screen, 1st status line: ERROR
- Operator's panel, Main Screen, 2nd status line: IRC encoder
- Error Screen:
 - Bad IRC encoder
 - or IRC is disconnected
 - or motor M1 is not moving
 - or etc.

Status correction:

- First it is necessary to establish if the error is in the pulse generation or on the main drive. You can check it as follows:
 - Press the “START” button/indicator again to quit the error, if the error persists, it will appear again.
 - If the laminating roll turned by approximately 1 in. (1 cm), the error is on the pulse generation.
 - If the laminating roll did not turn at all, there is an error in the main drive function.
- Correction of the error in the pulse generation:
 - The error is possibly caused by disconnection of conductors 601, 602 (phase A, phase B of the IRC encoder) or 217, 215 (24 Vdc, 0V supply to the IRC encoder). Repair. See DA-41-100n, sheet 6.
 - Defective IRC encoder. Replace it.
 - Defective rapid inputs X0, X1 on PLC of the machine control system. Replace.
- Correction of the errors in the main drive function:
 - The error may be caused by disconnection of conductor 906, which controls frequency inverter U1. Repair it. See DA-41-100n, sheet 9
 - Frequency inverter U1 failed. Reset the error by the control unit or by switching the machine off and on. More detail about the frequency inverter - see the Mitsubishi manual.
 - Frequency inverter U1 is defective. Replace it.
 - Motor M1 is defective. Replace it.
 - The error may be caused by disconnection of conductors 309, 310, 311 – interconnection between frequency inverter U1 and motor M1. Repair. See DA-41-100n, sheet 3.
 - The error may be caused by disconnection of conductors 307, 308, N – power supply to the frequency inverter. Repair. See DA-41-100n, sheet 3.

3.2.9 Error – the loading table is in the upper limit position*Status indication:*

- Yellow ERROR indicator is lit up continuously.
- Operator's panel, Main Screen, 1st status line: ERROR
- Operator's panel, Main Screen, 2nd status line: Feeder top
- Error Screen:
 - Feeder is in upper position
 - Press button Feeder DOWN

Status correction:

- Move the loading table down and quit the error by pressing the “FEEDER DOWN” button and simultaneously move the loading table off the top limit switch.

3.2.10 Status – the loading table is in the bottom limit position

Status indication:

- Operator's panel, Main Screen, 1st status line: STATUS
- Operator's panel, Main Screen, 2nd status line: Feeder bottom
- Error Screen:
Feeder is in bottom position
Press button Feeder UP

Status correction:

- Move the loading table up and quit the machine status by pressing the “FEEDER UP” button and simultaneously move the loading table off the bottom limit switch.

3.2.11 Error of the communication with frequency inverter U1

Status indication:

- START button/indicator is blinking.
- Yellow ERROR indicator is lit up continuously.
- Operator's panel, Main Screen, 1st status line: ERROR
- Operator's panel, Main Screen, 2nd status line: Communication U1
- Error Screen:
Error communication with
frequency inverter U1
Check connection and
switch machine ON and OFF

Status correction:

Note:

This error can be stopped with the “START” button/indicator. The machine will work without a problem but the speed of the main motor will not be displayed.

- Check if the conductors of the connecting cable between PLC, the machine control system and frequency inverter U1 are not disconnected. See DA-41-100n, sheet 14. Repair. Switch the machine off and on.
- Defective communication module A7 on PLC of the control system. Replace it.
- Frequency inverter U1 is defective. Replace it.

3.2.12 Error of the communication with frequency inverter U2

Status indication:

- START button/indicator is blinking.
- Yellow ERROR indicator is lit up continuously.
- Operator's panel, Main Screen, 1st status line: ERROR
- Operator's panel, Main Screen, 2nd status line: Communication U2
- Error Screen:

Error communication with
frequency inverter U2
Check connection and
switch machine ON and OFF

Status correction:

Note:

This error can be stopped with the “START” button/indicator. The machine will work without a problem but the speed of the main motor will not be displayed.

- Check if the conductors of the connecting cable between PLC, the machine control system and frequency inverter U2 are not disconnected. See DA-41-100n, sheet 14. Repair. Switch the machine off and on.
- Defective communication module A7 PLC of the control system. Replace it.
- Frequency inverter U2 is defective. Replace it.

3.2.13 Error – alarm of the heating regulator - in the middle

Status indication:

- Yellow ERROR indicator is lit up continuously.
- Operator's panel, Main Screen, 1st status line: ERROR
- Operator's panel, Main Screen, 2nd status line: Alarm middle
- Error Screen:

Overheat lamination roller
- middle

Status correction:

- Check the value of the actual temperature of the laminating roll on the operator's panel. If it exceeds the set acceptable limit 300 °F (150 °C), the most probable cause of the error is broken solid state relay A2. See DA-41-100n, sheet 5. Replace it.
- The error will reset as soon as the temperature of the laminating roll in its middle drops below the set maximum acceptable limit 300 °F (150 °C).

3.2.14 Error – alarm of the heating regulator - on the end sides

Status indication:

Yellow ERROR indicator is lit up continuously.

Operator's panel, Main Screen, 1st status line: ERROR

Operator's panel, Main Screen, 2nd status line: Alarm end side

Error Screen:

Overheat lamination roller
- end sides

Status correction:

- Check the value of the actual temperature of the laminating roll end sides on the operator's panel in Basic Screen No. 2. If it exceeds the set acceptable limit 300 °F (150 °C), the most probable cause of the error is broken power solid state relay A1. See DA-41-100n, sheet 5. Replace it.
- The error will reset as soon as the temperature of the laminating roll on its end sides drops below the set maximum acceptable limit 27 °F (135 °C).

3.2.15 Error – temperature sensor Pt100 disconnected – heating in the middle

Status indication:

- Yellow ERROR indicator is lit up continuously.
- Operator's panel, Main Screen, 1st status line: ERROR
- Operator's panel, Main Screen, 2nd status line: Pt100 middle
- Error Screen:

Sensor of temperature
is disconnected
- middle

Status correction:

- The error is possibly caused by disconnection of conductors 509, 510 or of the connector connection of these conductors. See DA-41-400n sheet, 4. Repair.
- A possible error of sensor Pt100 - ST1. Replace it.
Note:
At 80 °F (25 °C) it is possible to measure the resistance of this sensor of approximately 110Ω for the orientation check of this sensor.
- The error will reset as soon as temperature sensor ST1 shows the correct value. The error can be suppressed by turning the heating off with the “HEATERS” rotary switch on the machine control panel to STOP.

3.2:16 Error – temperature sensor Pt100 short – heating in the middle*Status indication:*

- Yellow ERROR indicator is lit up continuously.
- Operator's panel, Main Screen, 1st status line: ERROR
- Operator's panel, Main Screen, 2nd status line: Pt100 middle
- Error Screen:
 - Sensor of temperature
 - is short
 - middle

Status correction:

- A possible error in the connection of conductors 509, 510 or in the connector connection of these conductors. See DA-41-400n, sheet 4. Repair.
- A possible error of sensor Pt100 - ST1. Replace it.
 - Note:**
 - At 80 °F (25 °C) it is possible to measure the resistance of this sensor of approximately 110Ω for the orientation check of this sensor.
- The error will reset as soon as temperature sensor ST1 shows the correct value. The error can be suppressed by turning the heating off with the “HEATERS” rotary switch on the machine control panel to STOP.

3.2.17 Error – temperature sensor Pt100 disconnected – heating on the end sides*Status indication:*

- Yellow ERROR indicator is lit up continuously.
- Operator's panel, Main Screen, 1st status line: ERROR
- Operator's panel, Main Screen, 2nd status line: Pt100 end side
- Error Screen:
 - Sensor of temperature
 - is disconnected
 - end sides

Status correction:

- The error is possibly caused by disconnection of conductors 511, 512 or of the connector connection of these conductors. See DA-41-400n, sheet 4. Repair.
- A possible error of sensor Pt100 – ST2. Replace it.
- **Note:**
- At 80 °F (25 °C) it is possible to measure the resistance of this sensor of approximately 110Ω for the orientation check of this sensor.
- The error will reset as soon as temperature sensor ST2 shows the correct value. The error can be suppressed by turning the heating off with the “HEATERS” rotary switch on the machine control panel to STOP.

3.2.18 Error – temperature sensor Pt100 short – heating on the end sides*Status indication:*

- Yellow ERROR indicator is lit up continuously.
- Operator's panel, Main Screen, 1st status line: ERROR
- Operator's panel, Main Screen, 2nd status line: Pt100 end side
- Error Screen:
 - Sensor of temperature
 - is short
 - end sides

Status correction:

- The error is possibly caused by disconnection of conductors 511, 512 or of the connector connection of these conductors. See DA-41-400n, sheet 4. Repair.
- A possible error of sensor Pt100 – ST2. Replace it.
- **Note:**
At 80 °F (25 °C) it is possible to measure the resistance of this sensor of approximately 110Ω for the orientation check of this sensor.
- The error will reset as soon as temperature sensor ST2 shows the correct value. The error can be suppressed by turning the heating off with the “HEATERS” rotary switch on the machine control panel to STOP.

3.2.19 Status – the stacking unit attached to the machine is not running (it is stopped)**Note:**

Applicable only in case a stacking unit is attached to the machine.

Status indication:

- START button/indicator is blinking.
- Yellow ERROR indicator is lit up continuously.
- Operator's panel, Main Screen, 1st status line: STATUS

Operator's panel, Main Screen, 2nd status line: Stacking mach.

Error Screen:

Stacking machine
is not running

Status correction:

- The attached stacking unit must be set into operation by pressing the “START” button before the machine is started. Then the laminating machine can be started with the “START” button.

3.2.20 Status – the embossing unit attached to the machine is not running (it is stopped)

Note:

Applicable only in case a embossing unit is attached to the machine.

Status indication:

- START button/indicator is blinking.
- Yellow ERROR indicator is lit up continuously.
- Operator's panel, Main Screen, 1st status line: STATUS
- Operator's panel, Main Screen, 2nd status line: Embossing m.
- Error Screen:

```
Embossing machine  
is not running
```

Status correction:

- The attached embossing unit must be set into operation by pressing the “START” button before the machine is started. Then the laminating machine can be started with the “START” button.

3.2.21 Status – the number of sheets reached (COUNTER DOWN)

Status indication:

- START button/indicator is blinking.
- Operator's panel, Main Screen, 1st status line: STATUS
- Operator's panel, Main Screen, 2nd status line: Count finished
- Error Screen:

```
Counting down is finished
```

Status correction:

- The laminating machine can be restarted by pressing the “START” button as long as setting of the counter of sheets does not have to be changed.

3.3 TROUBLESHOOTING – PROBLEMS ARE NOT INDICATED ON THE CONTROL PANEL

3.3.1 Error – heating on the laminating roll is not active – end sides or middle

Possible indications of statuses:

- Bad laminated sheets quality
- A Part of the laminating roll is colder than the others
- The difference between the sections on the laminating roll was established by the contact thermometer

Status correction:

- Check fuses FU1 (heating on the end sides) and FU2 (heating in the middle), if broken, replace them.
- Check if no error is reported when rotary switch HEATERS is turned to position START and contactor KM7 is activated. If not, the error is possibly caused by disconnection of conductors 1001, 215. See DA-41-100n, sheet 10.
- Check the correct function of power solid state relays A1 (heating on the end sides), A2 (heating in the middle). If defective, replace them.
- The error is possibly caused by disconnection of conductors 503 - N, 506 - N or it is probably in the connector connection of these conductors. See DA-41-400n, sheet 4. Repair.

3.3.2 Error – the snap roll is not turning while the machine is running and the SNAP MOTOR rotary switch is in the START position

Possible indications of statuses:

The snap roll is not turning while the machine is running and the “SNAP MOTOR” rotary switch is in the “START” position.

Status correction:

- Check circuit breaker FA2 if it is in position I. If not, set it to position I.
- The error is possibly caused by disconnection of conductors 312 - N, 313 – N, 314, 315, 316. See DA-41-100n, sheet 3. Repair.
- The error may be caused by disconnection of conductor 909, which control frequency inverter U2. Repair. See DA-41-100n, sheet 9.
- Frequency inverter U2 failed. Reset the error by the control unit or by switching the machine off and on. More detail about the frequency inverter - see the Mitsubishi manual.
- Frequency inverter U2 is defective. Replace it.
- Motor M2 is defective. Replace it.

4. SERVICE CENTERS

Please contact the GBC Service Centers if needed:

USA

GBC National Service
One GBC Plaza
NORTHBROOK, IL 60062
U.S.A.

Phone: +1 (847) 272 3700

Fax:

E-Mail:

Internet: www.gbc.com

EUROPE

GBC Film Group Europe
Mercuriusstraat 9
6468 ES KERKRADE
The NETHERLANDS

Phone: +31 (0) 45 535 7651

Fax: +31 (0) 45 535 7878

E-Mail: info@gbcfilms.com

Internet: www.gbcfilm.com

Notes

