AQUILA LAMINATOR OPERATION & MAINTENANCE MANUAL

© 2002 GENERAL BINDING CORPORATION. ALL RIGHTS RESERVED.

Do not duplicate without written permission.



The information in this publication is provided for reference and is believed to be accurate and complete. General Binding Corporation is not liable for errors in this publication or for incidental or consequential damage in connection with the furnishing or use of the information in this publication, including, but not limited to, any implied warranty of fitness or merchantability for any particular use.

General Binding Corporation reserves the right to make changes to this publication and to the products described in it without notice. All specifications and information concerning products are subject to change without notice.

Reference in this publication to information or products protected by copyright or patent does not convey any license under the rights of General Binding Corporation or others. General Binding Corporation assumes no liability arising from infringements of patents or any other rights of third parties.

This publication is copyrighted © 2002 by General Binding Corporation. All rights reserved. The information contained in this publication is proprietary and may not be reproduced, stored, transmitted, or transferred, in whole or in part, in any form without the prior and express written permission of General Binding Corporation.

Table of contents

1.0 Safety	
1.1 Explanation of symbols	1-1
1.2 General Rules of safety	1-1
1.3 Labels	1-3
Figure 1.3.1 Safety label placement	1-4
2.0 Warranty	
2.1 Limited warranty	2-1
2.2 Exclusions to the warranty	2-1
3.0 Specifications	
3.1 Film capacity	3-1
3.1 Film core	3-1
3.2 Operating speed	3-1
3.3 Weight	3-1
3.4 Dimensions	3-2
3.5 Electrical requirements	3-1
4.0 Installation	
4.1 Setting up the laminator	4-1
4.2 Know your laminator	4-2
5.0 Operations	
5.1 Components on the laminator	5-1
5.2 Control panel	5-6
Figure 5.2.1 Control panel	5-5
5.3 Feed table	5-7
5.4 Supply shaft	5-7
5.5 Film alignment	5-8
5.6 Tension knobs	5-8
6.0 Applications	
6.1 Film loading and threading	6-1
6.2 Starting an application	6-4
6.3 Speed and temperature guide	6-5
Figure 6.3.1 Chart for degrees Fahrenheit	6-6
Figure 6.3.2 Chart for degrees Celsius	6-6
6.4 Web diagrams	6-7
6.5 Helpful hints	6-8
6.6 Important points to remember	6-9

7.0 Maintenance and troubleshooting

7.1 Cabinets, cover and stand	7-1
7.2 Clean the rollers	7-1
7.3 Troubleshooting	7-2
Figure 7.3.1 Troubleshooting guide	7-3

8.0 Recommended spares

8.1 Spare parts list	8-1
----------------------	-----

1.0 Safety



CAUTION: Do not attempt to operate your Aquila Laminator until you completely read and understand this Operations Manual.

Your safety, as well as the safety of others, is important to General Binding Corporation. This section contains important safety information which must be adhered to while operating, cleaning and performing basic maintenance in and around the machine.

1.1 Explanation of symbols



INFORMATION: *[This symbol is used prior to, during and/ or after a step. Following this symbol is important information pertaining to current subject.]*



CAUTION: *[This symbol is used prior to a step. The information following this symbol is to inform you of how to avoid harm to you, others around you or to the equipment.]*



WARNING: *[This symbol is used prior to a step. The information following this symbol is to inform you of how to avoid a dangerous situation.]*



ELECTRICAL HAZARD: *[This symbol is used prior to a step. The information following this symbol is to prevent an electrical shock condition that may be caused by an operators action or machine function.]*

1.2 General rules of safety



ELECTRICAL HAZARD: Do not operate the laminator if power cord is damaged or frayed. You can be severely shocked, electrocuted or cause a fire.



WARNING: Do not operate this laminator if you are not physically, psychologically or emotionally fit. Do not operate this machine until you have been trained and read this manual in it's entirety.



WARNING: Do not wear ties, loose fitting clothes or dangling jewelry while operating or servicing the laminator. These items can get caught in the nip and choke you or you can be crushed or burned.



WARNING: Never tamper with the safety devices to increase the laminator's production capacity. In the event a safety device should fail, never attempt to bypass it for operation. Consult a service representative immediately.



WARNING: Never use this machine for any other purpose than its intended design and function.



WARNING: Do not make any modifications to this laminator. Unauthorized changes will void your warranty and may cause extensive repairs or create poor output quality.



WARNING: Do not attempt to repair or service the laminator. Disconnect the plug from the power receptacle and contact your local sales/ service representative.



CAUTION: Only use acceptable materials through this laminator. Unacceptable materials may cause damage to the rollers or cause poor output quality.



CAUTION: Always observe all warning labels placed at various points on the laminator. If you do not completely understand a label, contact your local service representative for further explanation.



CAUTION: Avoid contact with the heat roller during operation or shortly after power has been removed from the laminator.



CAUTION: Do not place the laminator on an unstable cart, stand or table. An unstable platform may cause the laminator to fall resulting in serious bodily injury.



CAUTION: When moving the laminator on a cart or stand, avoid quick stops, excessive force and uneven floor surfaces.



INFORMATION: Always disconnect the power plug from the receptacle to which it is connected and keep the power supply cord in your possession when moving the laminator.



INFORMATION: Any concerns for safety or operation should be brought to the attention of your local service representative immediately.

1.3 Labels

Safety warning labels are placed at various locations on the laminator. Do not remove any of these labels. They are placed for your safety as well as the safety of those working around you.

Below are illustrations of the safety labels and a description of their meanings.

Hot rollers

– The safety label below means that you could be burned and your fingers and hands could be trapped and crushed in the rollers. Jewelry and long hair could be caught in the rollers and you could be pulled into them.

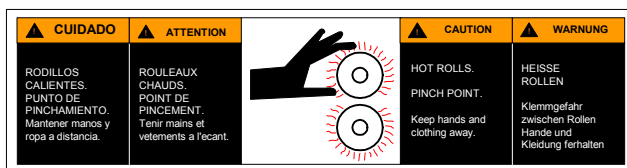

One label is placed on each side from the front operating position just in front of the heat rollers nip.

Electrical hazard

– The safety label below means that you could be seriously hurt or killed if you open the product and expose yourself to hazardous voltage.

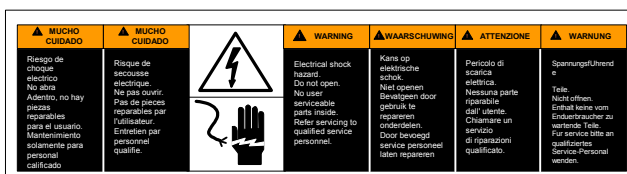

This label is located on the rear panel in the center of the laminator just below the film supply shaft between the pull rollers and decurling bar.

Pinch point

– The safety label below means use extreme caution when placing your hands in the proximity of the pull rollers nip. You should never place your fingers or other items in this area while the machine is running.



This label is located between the pull rollers and the decurling bar center of the rollers.

Refer to Figure 1.3.1 Safety label placement for illustration.

Figure 1.3.1 Safety label placement

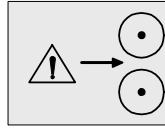

Use caution in proximity of pull rollers.

(1) Between pull rollers and decurling bar

▲ MUCHO CUIDADO	▲ MUCHO CUIDADO	▲ WARNING	▲ WAARSCHUWING	▲ ATTENZIONE	▲ WARNING
Riesgo de choque eléctrico. No abra. Advertir, no hay piezas reparables para el usuario. Mantenimiento solamente para personal cualificado.	Risque de secousse électrique. Ne pas ouvrir. Plus de pièces réparables par l'utilisateur. Entretien par personnel qualifié.	 <p>Electrical shock hazard. Do not open. No user serviceable parts inside. Refer servicing to qualified service personnel.</p>	<p>Kans op elektrische schok. Niet openen. Besluit niet te repareren of te onderhouden. Over serviceel service personeel laten repareren.</p>	<p>Peligco di scarica elettrica. Nessuna parte riparabile dall'utente. Chiamare un servizio di riparazioni qualificato.</p>	<p>Spanningsgevaar. Tele. Niet openen. Ervaakt keine von Endverbraucher zu wartende Teile. Für service bitte an qualifiziertes Service-Personnel wenden.</p>

(1) Center rear panel below film unwind.

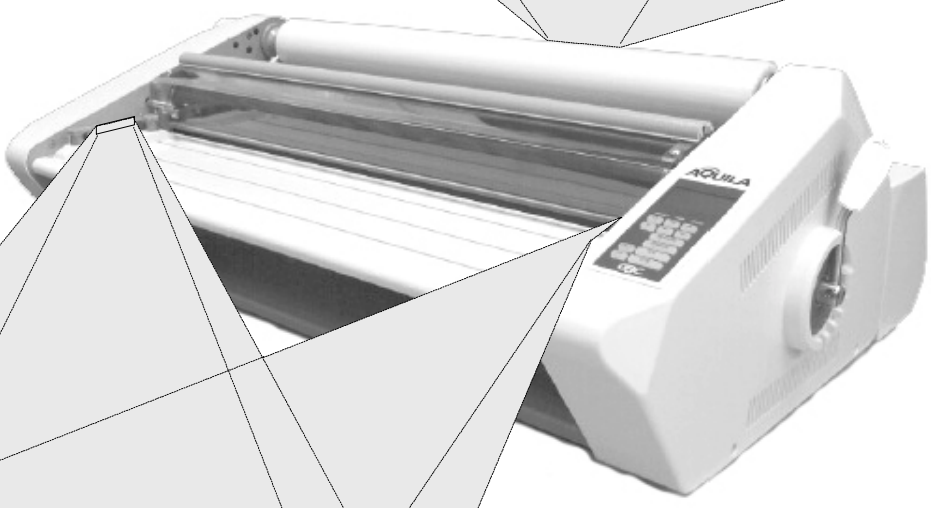

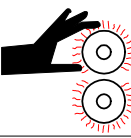
▲ CUIDADO	▲ ATTENTION	▲ CAUTION	▲ WARNING
<p>RODILLOS CALIENTES. PUNTO DE PINCHAMIENTO. Mantener manos y ropa a distancia.</p>	<p>ROULEAUX CHAUDS. POINT DE PINCEMENT. Tenir mains et vêtements à l'écart.</p>	 <p>HOT ROLLS. PINCH POINT. Keep hands and clothing away.</p>	<p>HEISSE ROLLEN. Klemmgefahr zwischen Rollen. Hände und Kleidung fernhalten.</p>

(2) One on each side of the laminator

2.0 Warranty

General Binding Corporation warrants the equipment to be free from defects in material and workmanship for a period of **90 days for parts and labor** from the date of installation. This warranty is the only warranty made by General Binding Corporation and cannot be modified or amended.

General Binding Corporation's sole and exclusive liability and the customer's sole and exclusive remedy under this warranty shall be, at General Binding Corporation's option, to repair or replace any such defective part or product. These remedies are only available if General Binding Corporation's examination of the product discloses to General Binding Corporation's satisfaction that such defects actually exist and were not caused by misuse, neglect, attempt to repair, unauthorized alteration or modification, incorrect line voltage, fire, accident, flood or other hazard.

2.1 Limited Warranty

This warranty specifically does not cover damage to the laminating rollers caused by knives, razor blades, other sharp objects, failure caused by adhesives or improper use of the machine. Warranty repair or replacement does not extend the warranty beyond the initial 90 day period from the date of installation.



CAUTION: Unauthorized customer alterations will void this warranty.

THE WARRANTY MADE HEREIN IS IN LIEU OF ALL OTHER WARRANTIES, EXPRESSED OR IMPLIED, INCLUDING ANY WARRANTY OR MERCHANTABILITY OR FITNESS FOR A

PARTICULAR PURPOSE. GBC FILMS GROUP WILL NOT BE LIABLE FOR PROPERTY DAMAGE OR PERSONAL INJURY (UNLESS PRIMARILY CAUSED BY ITS NEGLIGENCE), LOSS OF PROFIT OR OTHER INCIDENTAL OR CONSEQUENTIAL DAMAGES ARISING OUT OF THE USE OR INABILITY TO USE THE EQUIPMENT.

2.2 Exclusions to the Warranty

This warranty specifically does not cover;

1. Damage to the laminating rolls caused by knives, razor blades, other sharp objects or failure caused by adhesives.
2. Damage to the machine caused by lifting, tilting and/ or any attempt to position the machine other than rolling on the installed castors on even surfaces.
3. Improper use of the machine.
4. Damage due from unqualified person(s) servicing the machine.

Qualified;

- Any engineer that has experience with electrical and mechanical design of lamination equipment. The engineer should be fully aware of all aspects of safety with regards to lamination equipment.

- Any commissioning or service engineer must be of competent nature, trained and qualified to General Binding Corporation standards to fulfill that job. This person will have completed and passed the full service training course from General Binding Corporation.

- Any General Binding Corporation Technician and/ or General Binding Corporation Specialist that has been through the General Binding Corporation service training course.

This page intentionally left blank.

3.0 Specifications

This section provides specific information regarding the laminator. Any specification not provided must be requested from GBC.

3.1 Film and sheet size

Film	– 1.2, 1.7, & 3 Mil
Core	– 1 in. (2.54 cm)
Sheet Size	– Min. Width 2 in. (5 cm) – Max. Width 25 in. (64 cm) – Min. Length 4 in. (10 cm) – Max. Length unlimited

3.2 Functions

Speed	– 1.0 - 5.0 fpm (30.5 cm - 1.5 m)
Temperature	– 32 - 326 °F (0 - 163 °C)
Cooling fans	– 5 fan bank system

3.3 Weight

Unpacked	– 132 lbs. (60 kilograms)
Shipping Weight	– 143 lbs. (64.4kilograms)

3.4 Dimensions (W x H x D)

Refer to **Figures 3.4.1 Dimensions**.

Machine	– 23.75 x 24 x 12 in. – (60 x 61 x 31 cm)
----------------	--

3.5 Electrical requirements



INFORMATION: Refer to the serial plate located on the rear of the laminator for specific electrical ratings applicable to the unit.



Voltage	– 110V ~ 60Hz
Current	– 10A
Power	– 1100 W

Figure 3.4.1 Dimensions



4.0 Installation

This section will guide you through the installation process of the laminator.



INFORMATION: Shipping damage should be brought to the immediate attention of the delivering carrier.

4.1 Setting up the laminator

1. Place the Aquila laminator on a stable flat surface capable of supporting at least 95 lbs. (45kgs).

The surface should be at least 30 inches high to assure comfortable positioning during operation.



CAUTION: Too high or too low of an operating position can lead to serious bodily injury and or cause poor output quality.

All four rubber support feet should be positioned completely on the supporting surface.



CAUTION: The laminator is a heavy piece of equipment and may cause injury and/ or require extensive repair work if it falls.

The supporting surface may also be large enough to hold the material being laminated.

2. The laminator should be positioned to allow exiting film to drop freely to the floor. The drop rollers should hang over the edge of the table.



CAUTION: Accumulation of laminate immediately behind the laminator as it exits the equipment may cause the film to wrap around the pull rollers, resulting in a “jammed” condition.

3. Avoid locating the laminator near sources of heat or cold. Avoid positioning the laminator in the direct path of forced heated or cooling air.



INFORMATION: This effects the performance of the heating system and could result in poor output quality.



CAUTION: The stand and laminator should only be moved across even flat surfaces by two or more people. Do not turn the laminator on its side or up side down to move.

4. Connect the attachment plug provided with the laminator to a suitably grounded outlet only.

Refer to Section 3.6 Electrical Requirements



CAUTION: Avoid connecting other equipment to the same branch circuit to which the laminator is connected, this may result in nuisance tripping of circuit breakers or blowing fuses.

4.2 Know your laminator

This section will assist you in understanding what and where items are when referred to in the manual.

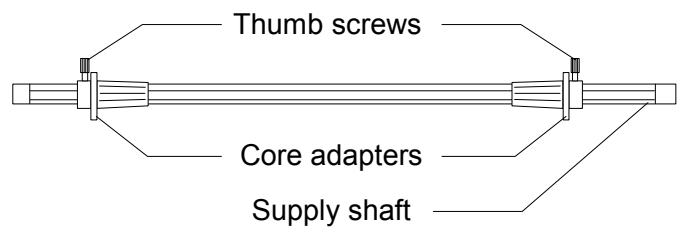
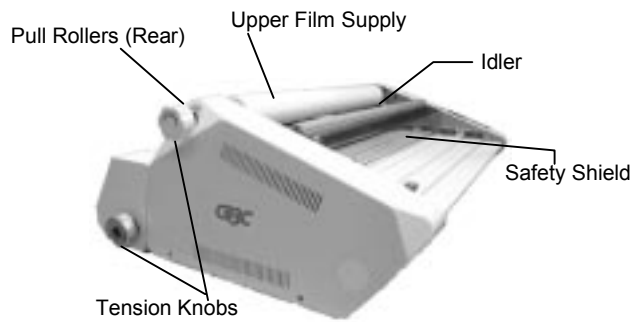
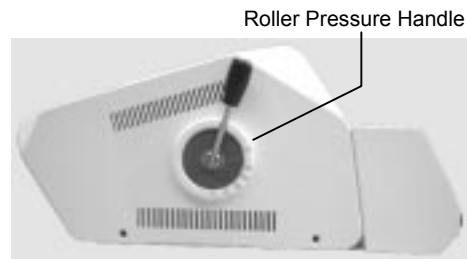
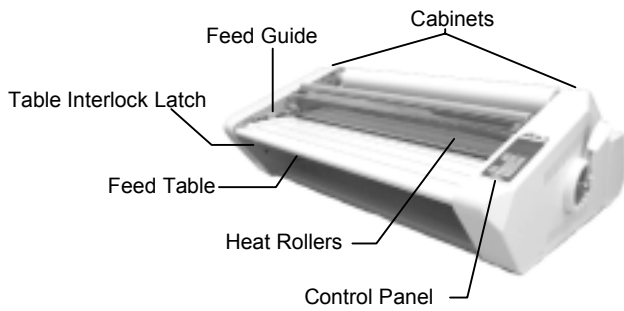
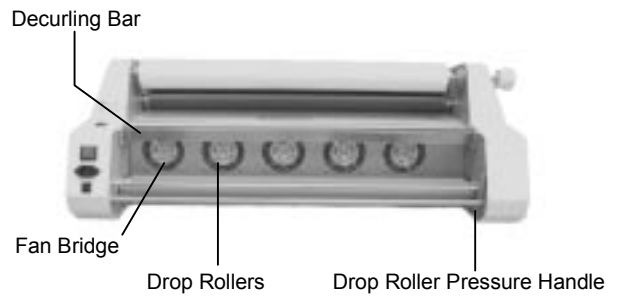
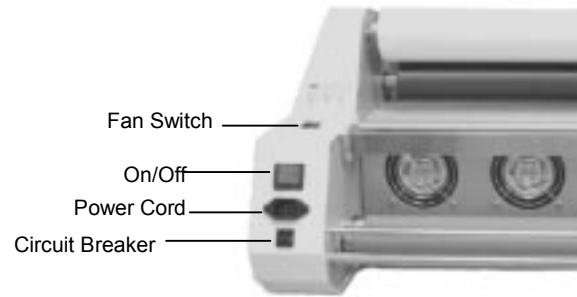
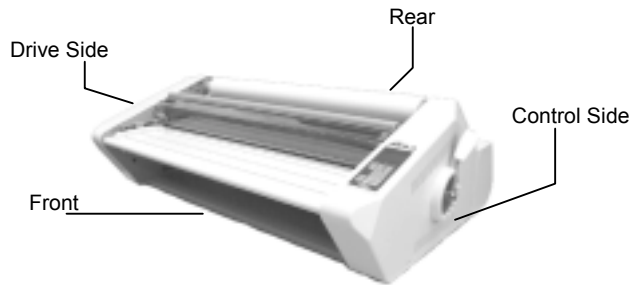

5.0 Operation

This section covers the components of the laminator, the control panel, feed table, supply shaft, film alignment and tension knobs.

5.1 Components on the laminator

(1) POWER ON/ OFF: This is located at the back of the control side cabinet. When set to the “I” position, applies power to the laminator. When set to the “O” position, removes power from the laminator.

(2) CIRCUIT BREAKER: Electrical safety device, located under the drive side cabinet cover, can be reset by the operator if tripped.



CAUTION: If the circuit breaker trips a second time after being reset, contact your service representative for assistance.

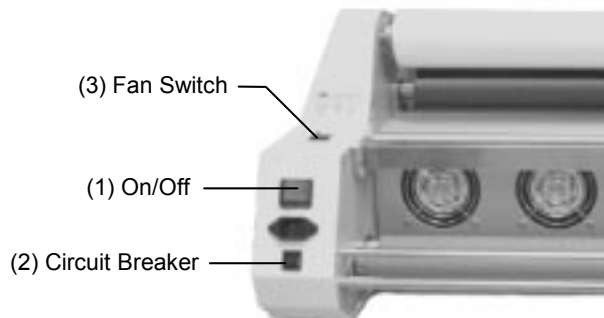

(3) FAN ON/ OFF: This is located at the back of the control side cabinet near the drop rollers. When set to the “I” position with motor engaged, applies power to the fan bank. When set to the “O” position, removes power from the laminator.

(4) MAIN ROLLER SAFETY SHIELD: Prevents entanglement, entrapment and inadvertent contact with the heat rollers.



INFORMATION: The laminator will operate only when the safety shield is located in the fully down position. Power to the motor is removed when the safety shield is in the raised position.

(5) MAIN ROLLER SAFETY SHIELD INTERLOCK LATCH: Used to lock the safety shield into position and activate an interlock switch. This interlock latch is located on the drive side from the front operating position.

To raise the main roller safety shield, retract the interlock latch and lift. Once the interlock latch has been retracted, power to the motor is removed.



To close the the safety shield, lower and align the interlock latch with its locked position. If the motor will revert to its condition prior to the safety shield being raised.

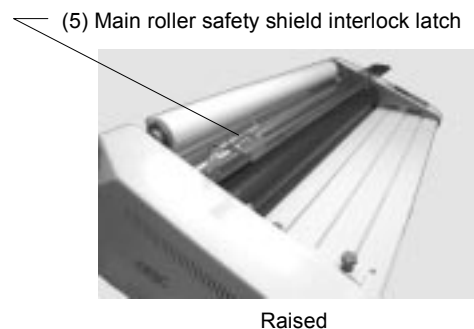

(6) DROP ROLLER SAFETY SHIELD: Prevents entanglement, entrapment and inadvertent contact with the drop rollers.



CAUTION: Never force the pressure handle down. If the handle does not move smoothly, contact your local service representative.

(7) DROP ROLLER LEVER: Lever located at rear of machine, next to drop rollers. Used to engage drop rollers. Used to pull image over decurling bar to ensure flat output.

(8) FANS: The fan bridge is located in the back of the machine. The fans are used to cool the finished material.

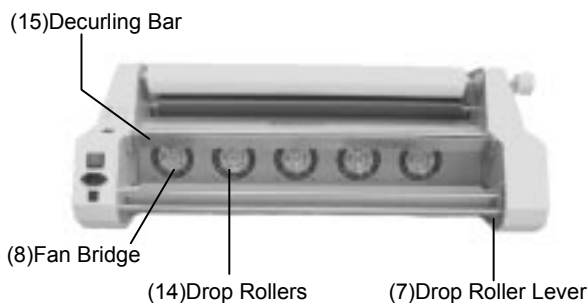

(9) FEED TABLE: The feed table is used to position items for lamination.

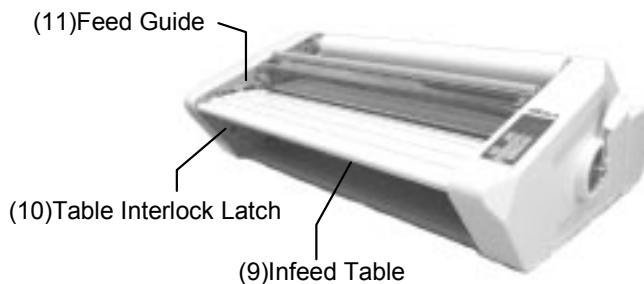

INFORMATION: The laminator will operate only when the feed table is installed and the table interlock latch is properly engaged.

(10) TABLE INTERLOCK LATCH: Used to lock the feed table into position and activate an interlock switch. This interlock latch is located on the underside of the feed table on the drive side from the front operating position. The table can not be removed without retracting the latch

(11) FEED GUIDE: The feed guide permits alignment of the item(s) to be laminated and is used to keep longer items straight.

To position the adjustable guide, loosen the knob on the top of the guide, slide it to the desired position and tighten the knob to secure in place.

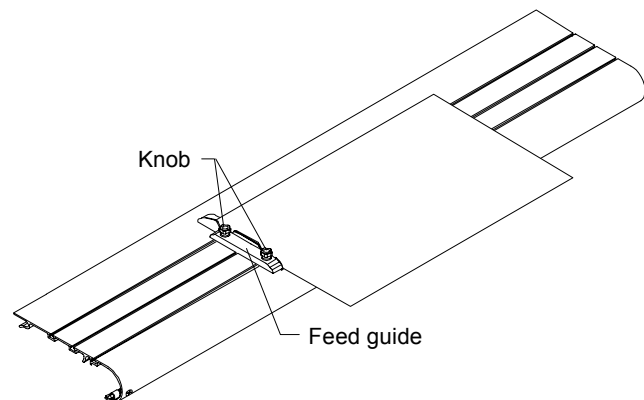

CAUTION: The feed guide should be set outside the width of the film. The film should be completely inside the sheet being fed.

(12) MAIN ROLLER: Teflon coated steel tube. Used to heat the laminating film and compress the film to the items being laminated. Heat is provided by an internal infrared element.



WARNING: Avoid contact with the heat roller. Direct contact with the heat roller can burn you.

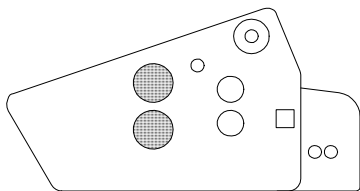

(13) PULL ROLLERS: The bottom pull roller, located in the middle of the laminator, is motor driven. When Rollers are in the down position, they simultaneously pull the film and improve the quality of the laminated item.

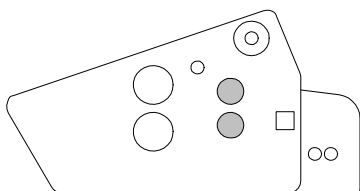

(14) DROP ROLLERS: One of the drop rollers, located at the back of the laminator is also motor driven. They pull the laminate over the decurling bar correcting any curl to the finished product.

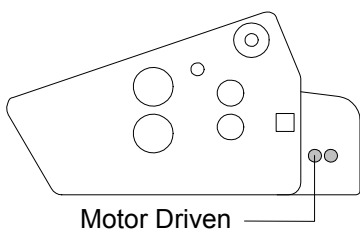

(15) DECURLING BAR: The curling bar is located in the middle of the machine, just past the pull rolls. Each side of the curling bar has a different radius to ensure the output of the finished product lays flat.

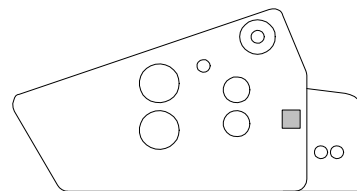

(16) IDLER BAR: The idler bar, located near the supply roll, is used to direct the film to the heat rollers.

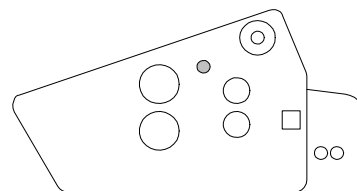

(17) SUPPLY SHAFT: The supply shaft holds the film supply and the core adapters hold the rolls of film on the film shaft.

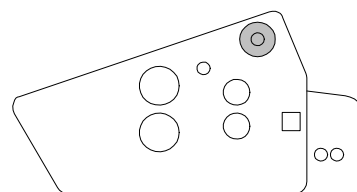

(18) CORE ADAPTERS: The film shaft holds the supply roll while the core adapters hold the rolls of film on the shaft.



CAUTION: Never force the pressure handle down. If the handle does not move smoothly, contact your local service representative.

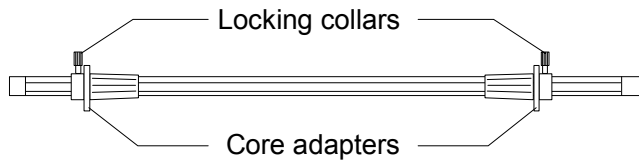

(19) FILM WEB: Laminating film loaded into the machine

(21) NIP POINT: The point at which two rollers come into contact. The nip point of the heat rollers is the place at which the items for lamination are introduced into the laminator.

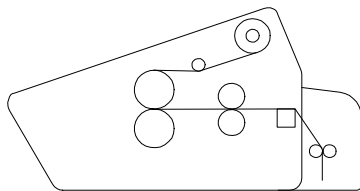

CAUTION: Only feed acceptable materials through the nip of the rollers. Unacceptable materials may cause damage to the rollers.

(20) PRESSURE HANDLE: Located on the control side cabinet. Used to adjust the amount of roller pressure needed for various laminating applications.

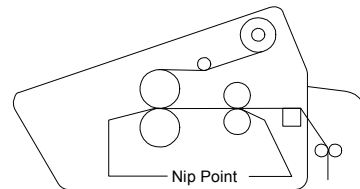

- Mounting-
 - 3/16in./ 5mm.
 - 1/8in./ 3mm.
 - 1/16in./ 2mm.
 - 1/32in./ 1mm.
- Laminating-
 - 1.5mil/38mic.
- Heavy Gauge- laminating films thicker than 1.5 mil (38 mic)

(22) FILM TENSION KNOB: Allows the operator to increase or decrease film web tension as necessary to reduce curl and wrinkles. Refer to Section 4.6 Adjusting film tension for more information on tension.

(20) Roller Pressure Handle

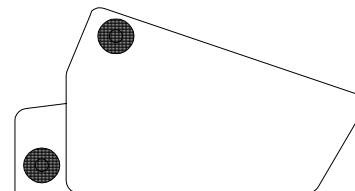
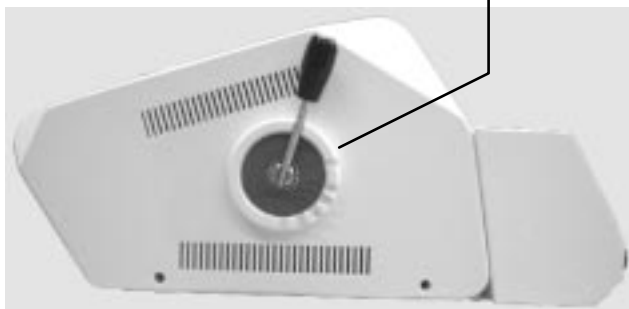
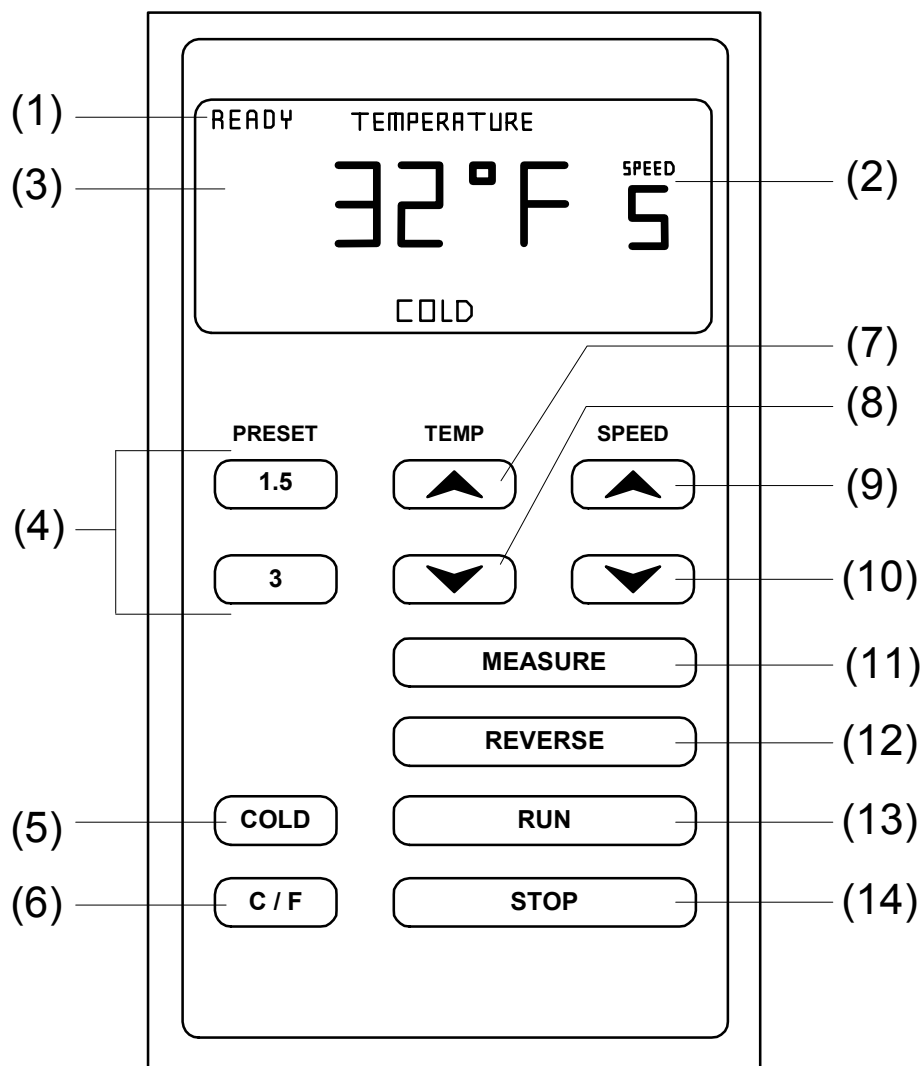

Figure 5.2.1 Control panel



5.2 Control panel

Refer to Figure 4.2.1 Control panel

(1) READY: Indicates when the laminator has sufficient heat for the selected film gauge. Flashes when the temperature is close to the set point or overshoots the set point.

(2) SPEED: Indicates the speed of the motor.

(3) TEMPERATURE: indicates the programmed temperature setting in either degrees Fahrenheit or degrees Celsius.

(4) PRESETS: When 1.5, or 3 is pressed, the speed and temperature are automatically set for NAP LAM II film and 20 lb. paper stock (copier paper). Refer to the speed and temperature guide in Section 4.6 for manual and preset conditions.

(5) COLD: Turns power to the heaters off for cold lamination.

(6) C/F: Allows the operator to control the unit of measurement displayed. The display will toggle between Fahrenheit and Celsius.

(7) TEMP ▲: When pressed, allows the operator to increase the temperature, overriding the preset condition.

(8) TEMP ▼: When pressed, allows the operator to decrease the temperature, overriding the preset condition.

(9) SPEED ▲: When pressed, engages motor and allows the operator to increase the speed of the laminator, overriding the preset condition.

(10) SPEED ▼: When pressed, allows the operator to decrease the speed of the laminator, overriding the preset condition.

(11) MEASURE: When pressed, permits the operator to read the current temperature of the rollers.

(12) REVERSE: When pressed and held, reverses roller direction to clear film jams and wrap-ups. Motor must be engaged for reverse operation.

(13) RUN: When pressed, activates rollers for normal operation.

(14) STOP: When pressed, stops the rotation of the rollers.

5.3 Feed table

To remove

1. Lift the safety shield to its full upright position.
2. Slide the feed table interlock latch to the right.
3. Lift the rear of the table (the rounded side) upwards and away from the laminator.

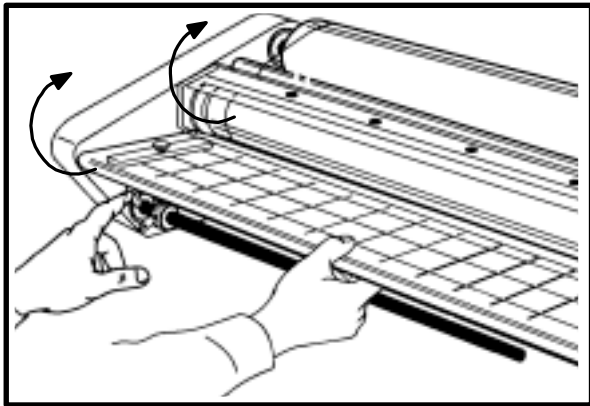

To replace

1. Set the front of the feed table (the side that is not rounded) into the table brackets first.
2. Lower the rear of the feed table onto the table support bar.
3. Slide the table interlock latch to the left.
4. Lower the safety shield to its fully closed position.

5.4 Supply shaft

To remove

1. Slide the upper shaft to the right from the front operating position.
2. While pushing in on the supply shaft to the right, remove the left side of the shaft from the brake assembly.

To replace

1. Align the rounded end of the supply shaft into the supply shaft hole located on the right side of the laminator from the front operating position.
2. Push the supply shaft in while aligning the hex end of the supply shaft with the brake assembly.

5.5 Film alignment

The film supply shaft come with pre alignment holes on the right side.

Aquila - Has pre alignment holes for 9 in. (21 cm) and 12 in. (31 cm) film widths.

1. Loosen the thumb screw on the right side core adapter.
2. Move to the corresponding hole to match the width of your roll of film.
3. Tighten the thumb screw in the pre drilled hole.

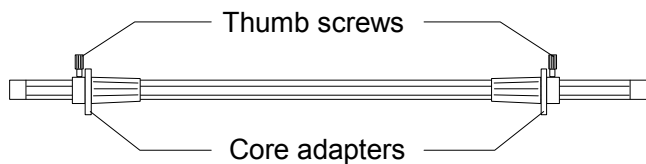

5.6 Tension knobs

Allows the operator to increase or decrease film web tension as necessary to reduce curl and wrinkles. Refer to Page 5-3, Adjusting film tension for more information on tension.

To increase tension

1. Turn the tension knob as indicated below.

Tension Knobs



To decrease tension

1. Turn the tension knob as indicated below.

Tension Knobs



6.0 Applications

The Aquila will accommodate rolls of film on a 1 in. core. This section will describe how to load and thread film and start an application. Included in this section are speed and temperature guide, web diagrams, helpful hints and important points to remember.



WARNING: Do not wear ties, loose fitting clothes or dangling jewelry while operating or servicing the laminator. These items can get caught in the nip and choke you or you can be crushed or burned.

6.1 Film loading and threading

1. Turn power to ON.



2. Ensure the roller nip is open and enter a temperature or press one of the preset film options.

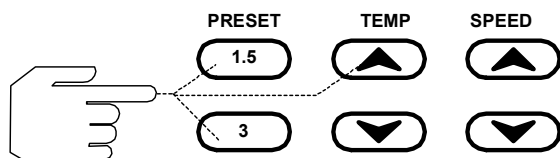

3. Remove the unwind shaft from the laminator. Remove the core adapters from the unwind shaft.

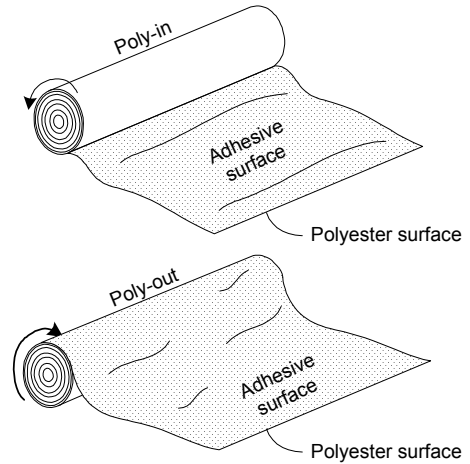

CAUTION: The dull side of the film contains the adhesive. Use extreme caution when loading delustered (matte) film as both sides appear dull.

4. Slide the roll of laminating film onto the unwind shaft so the adhesive is facing away from the heat roller when placed on the laminator.

Poly-in film

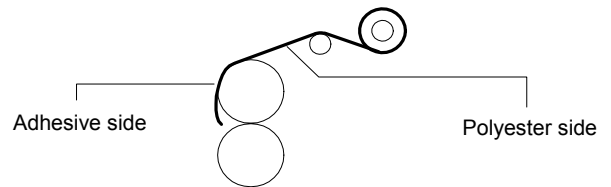

Poly-out film

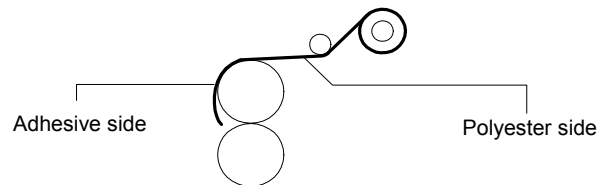

5. The film should be center of the heat roller. Once the film is centered, secure in place by tightening the thumb screws on the core adapters.



CAUTION: The **READY** indicator on the display should be illuminated. This is your indication that the roller has sufficient heat.

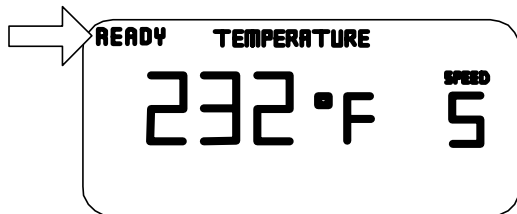

6. Remove the main roller safety shield for ease of webbing the film.



7. Pull the upper laminating film down over the upper idler, over the heat roller and allow to drape over the feed table.



8. Slide the threading card (a piece of heavy stock paper, card board or similar product) between the feed table and the film resting on the feed table. Push the threading card into the nip of the main rollers.

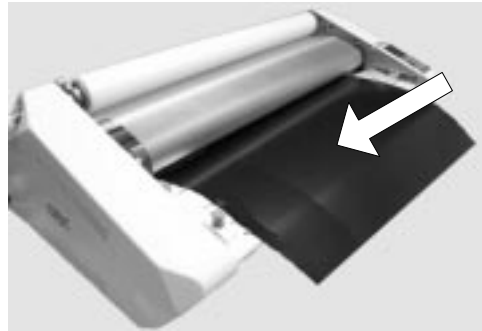

CAUTION: The threading card should exceed the width of the film to prevent activated adhesive from adhering to the bottom roller.

9. Lower the main roller pressure handle to the related film setting position.

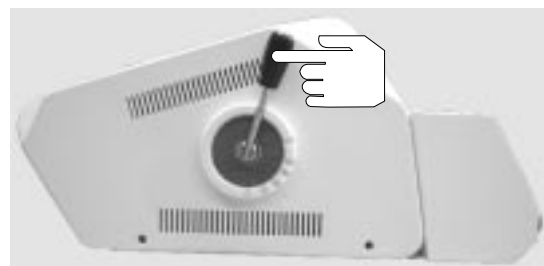

10. Press **RUN** on the control panel.

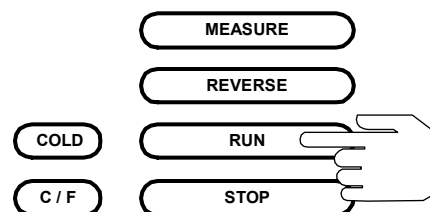

11. While the threading card is being taken through the rollers, use this time to adjust film tension.



12. Once the threading card has entered the laminator, let the card proceed until the card is almost completely through the nip. Before the threading card is completely through the nip, insert next object to be laminated, overlapping the card slightly. Remembering that overlapping is necessary, continue with next sheet. Repeat.

13. When the job is complete. Trim the threading card off and release roller pressure using the roller pressure handle.



CAUTION: Exercise extreme caution when using an open blade around the laminator. A sharp knife can cut you and/ or the rollers.

6.2 Starting an application



CAUTION: Ensure the safety shield is in the fully closed position and the feed table is properly installed with the table interlock latch in position.

1. Turn the laminator on by pushing the On/Off switch to the “I” position.

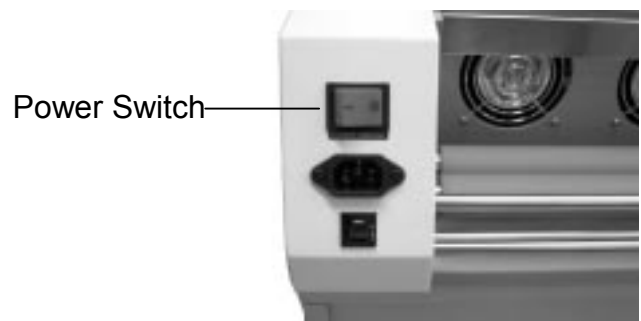

2. The laminator will automatically default to the **COLD** setting which is used for PSA film. .

3. When you are using thermal film, you must manually press the 1.5, or 3, MIL button. The laminator will set the speed and temperature for the respective film and 20 lb. bond paper (copier paper). If you are using NAP I film, the heat and speed will be different.

Refer to Section 4.8 Speed and temperature guide



INFORMATION: Use the ^ or v buttons below TEMP or SPEED to adjust the temperature and/or speed settings



INFORMATION: When using thermal film, do not begin laminating until the **READY** indicator illuminates. Normal warm up time is approximately ten minutes.

4. Adjust the feed guide and position the item(s) on the feed table to be laminated.



CAUTION: Anything obstructing the path of the film exiting the rear of the laminator may cause a film jam (wrap-up).

5. Set the roller pressure handle to the appropriate position and press **RUN**. The rollers will begin to turn.

6. Wait for the heat line (dwell line) to disappear, then push the items into the nip point of the heat rollers. Additional items can be laminated without stopping and starting the laminator.

7. Once the last item laminated has completely exited the rear of the laminator, press the **STOP** button.

8. Turn the laminator off by pushing the On/Off switch to the “**O**” position.



INFORMATION: You do not need to un-web the laminator after turning power off except to clean the rollers. Refer to Section 5.1 Cleaning the rollers.

Figure 6.3.1 Chart for degrees Fahrenheit

Stock	Film guage	Nap-Lam II		Nap-Lam I		Hi-Tac	
		Preset conditions		Settings		Settings	
	Mil	Temp (F)	Speed	Temp (F)	Speed	Temp (F)	Speed
20# Bond	1.5	248	8	290	7	255	8
	3	239	6	270	5		
80# Bond	1.5	248	6	295	7	255	6
	3	239	5	275	5		
10 pt. Board	1.5	248	5	300	6	255	4
	3	239	4	275	4		

You may have to adjust temperature or speed depending on stock finish, thickness and ink coverage.

* Turn heat off when not in use.

Figure 6.3.2 Chart for degrees Celsius

Stock	Film guage	Nap-Lam II		Nap-Lam I		Hi-Tac	
		Preset conditions		Settings		Settings	
	Mic	Temp (C)	Speed	Temp (C)	Speed	Temp (C)	Speed
20# Bond	38	120	8	143	7	123	8
	75	115	6	132	5		
80# Bond	38	120	6	146	7	123	6
	75	115	5	135	5		
10 pt. Board	38	120	5	149	6	123	4
	75	115	4	135	4		

You may have to adjust temperature or speed depending on stock finish, thickness and ink coverage.

* Turn heat off when not in use.

6.3 Speed and temperature guide

Figure 6.3.1 and Figure 6.3.2 are speed and temperature charts that provide general guidelines for proper heat and speed settings for use on certain materials and laminating film combinations.



INFORMATION: Different settings may become necessary as the warm up time, lamination time and materials change.



INFORMATION: You may have to adjust temperature or speed depending on stock finish, thickness and ink coverage.

Figure 6.3.1 Chart for degrees Fahrenheit and Figure 6.3.2 Chart for degrees Celsius are on the page 4-6.

6.4 Web diagrams

Use the web diagrams to perform various applications.

Encapsulation (Poly-in film)

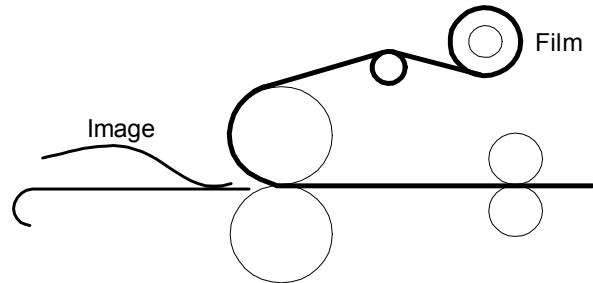

Encapsulation (Poly-out film)

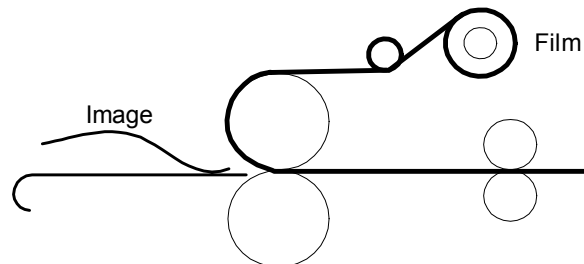

6.5 Helpful hints

Good consistent lamination is a result of combining proper heat, speed, tension and dwell time. Dwell time is the amount of time the material to be laminated is compressed between the heat rollers and is controlled by the speed of the laminator.

As a general rule, thicker items and films as well as items with dark or full ink coverage, need to run at a slower speeds because they extract more heat from the rollers at a quicker rate.

Thinner items, such as standard copier paper (20lb.bond) and tissue stock, extract less heat from the rollers and can be run at faster speeds.

Operation of the laminator for more than thirty minutes at a time may necessitate a lower speed setting. It is recommended that during periods of long runs the items being laminated are alternated between thick and thin.

If you are ever unsure that your laminator is set at proper speed, run a test piece (scrap) of the same or similar material through the laminator. Rotating the heat rollers prior to laminating distributes the heat evenly throughout the heat rollers.

Always use the minimum brake tension necessary to achieve the desired results. Using the maximum amount will yield unwanted results after close inspection. You may see stretching, waves in the laminate, distortion of the image and/or curling.

6.6 Important points to remember



WARNING: Do not press RUN until READY has illuminated.



WARNING: To cut film or web, only use an enclosed blade around the laminator.



WARNING: Do not force items into the laminator. An item that is not easily drawn into the laminator is probably to thick to laminate.



WARNING: Do not attempt to laminate abrasive or metal objects such as staples, paper clips and glitter as they may damage the heat rollers.



WARNING: Do not attempt to laminate adhesives marked "FLAMMABLE".



CAUTION: Avoid direct contact with the heat rollers when changing the supply roll after the laminator has been running.



CAUTION: Do not stop the laminator before an item has completely exited the pull rollers. Even a momentary stop will cause a dwell line (heat line) on the laminated item.



INFORMATION: Wrinkles may result if an attempt is made to reposition an item once it has entered the nip of the heat rollers.



INFORMATION: When feeding long items, skewing may occur if the item is not fed into the laminator straight. Use the feed guide to help prevent this from happening.



INFORMATION: If the machine is not working, always check that the safety shield is properly closed, the feed table is properly installed and the circuit breaker has not tripped before placing a service call.

7.0 Maintenance & Troubleshooting

General Binding Corporation laminators require minimal maintenance. However, regular maintenance is essential to keep any piece of precision machinery at peak performance. A maintenance schedule and a section of procedures are included in this section.



WARNING: Do not wear ties, loose fitting clothes or dangling jewelry while operating or servicing the laminator. These items can get caught in the nip and choke you or you can be crushed or burned.



INFORMATION: Improper maintenance can result in poor output quality.

General Binding Corporation offers Cleaning kits (P/N 1711515) as well as Extended Maintenance Agreements.

The only maintenance required by the operator is to maintain clean and adhesive free nip rollers and overall cleanliness of the laminator itself.



ELECTRICAL HAZARD: Do not use liquid or aerosol cleaners on the laminator. Do not spill liquid of any kind on the laminator. You can be severely shocked, killed or cause a fire. Use only a damp cloth for cleaning unless other wise specified.

7.1 Cabinets, cover and stand



ELECTRICAL HAZARD: Remove power from the laminator before cleaning. You can be severely shocked, killed or cause a fire.

1. Use a damp (use water only to dampen the cloth) white terry cloth towel to wipe dust from the cabinets, cover and stand.

7.2 Clean the rollers



CAUTION: This procedure is performed while the laminator is HOT! Use extreme caution. Direct contact with the rollers can burn you!



CAUTION: Hardened adhesive deposits on the rollers can cause damage to the rollers. Rotate the rollers at the lowest speed setting on the control panel.



WARNING: Do not apply cleaning fluids or solvents to the rollers! Fluids and solvents will have a direct effect on the rubber coated rollers and will require replacement.



WARNING: Do not use metal scouring pads to clean the rollers! Scouring pads will damage the rollers and require replacement.



WARNING: Never clean the rollers with sharp or pointed objects.

1. Remove the film from the laminator.
2. Preheat the laminator until the **READY** indicator illuminates.
3. Rub the top and bottom heat rollers with a 3M™ Scotch-Brite™ pad.
4. Install the feed table and lower the safety shield.
5. Press **RUN** to rotate the heat rollers to a new area for cleaning. Press **STOP**. Continue this process until the complete surface of both rollers are clean.
6. Follow the procedure in Section 4.6 Film loading and threading to reload the laminator.

7.3 Troubleshooting

As an operator, you can perform some basic troubleshooting before contacting your local service representative.



WARNING: Never remove the cabinets in attempt to troubleshoot the laminator. You may cause damage to other components or injury to yourself.



ELECTRICAL HAZARD: Do not remove the cabinets. You will be exposed to dangerous voltage which can shock or paralyze you.



CAUTION: Only trained technicians should perform service related work on the laminator.

Refer to **Figure 7.3.1 Troubleshooting Guide** on page 7.3.

Figure 7.3.1 Troubleshooting guide

Symptom	Possible cause	Corrective action
•POWER lamp does not illuminate when ON/OFF is in the ON position.	Laminator not connected to the electrical supply.	Insert attachment plug into receptacle.
• Heat rollers do not turn.	Circuit breaker open.	Reset circuit breaker.
	Safety shield in upright position.	Lower safety shield.
	Feed tray interlock pin not in place.	Slide interlock lever all the way into the left side frame.
• Laminated items exhibit curling.	Tension on the top film is too tight.	Adjust tension per section Film Tension Adjustment .
	Tension on top roll of film is too loose.	Adjust tension per section Film Tension Adjustment .
	Speed setting too slow.	Slightly speed up laminator.
	Top film roll may be improperly loaded.	Make sure top roll of film is around idler bar.
• Adhesive deposited on the heat rollers.	Heat rollers were lowered with no paper stock between them.	Avoid running the laminator without paper stock.
	Laminate improperly loaded.	Adhesive (matte) side of laminate film may be against the heat rollers. Load film per procedure outlined in section Film Loading and Threading .
• Unsatisfactory adhesion of laminate.	Speed setting too fast for type of material being laminated.	Lower speed setting by pressing SLOW .
	Insufficient heat.	READY must be illuminated.
	Laminate improperly loaded.	Adhesive side of film must be facing away from the heat rollers.
	Heat rollers require cleaning.	Clean heat rollers per section To Clean The Rollers .
	Laminated item unsuitable for adhesion.	Item may be dirty or may have non-porous surface that is extremely difficult to laminate.

This page intentionally left blank.

8.0 Recommended spares

8.1 Spare parts list

Side Cover (L):	604022101
Side Cover (R):	604022102
PCB Display:	706011107
Rubber Key:	704090320
Display Panel:	703020203
Display Decal:	802105047
Tension Decal:	803040315
Core Adapters (1 in.):	604037021
Film Shaft:	613030202
Core Adapter Bolt:	613030527
Film Shaft Bushing:	613030301
Pull Roller:	607040503
Drop Roller:	613030176
Teflon Roller:	607040522
Heat Roller:	607040513
Heater Ass'y:	706025063
Temp. Sensor:	705200201
Main PCB:	706011106
DC Geared Motor:	6090202

This page intentionally left blank



General Binding Corporation
One GBC Plaza
Northbrook, IL 60062-4195