

OPERATION MANUAL LAMINATOR

MODELS 6250 AND 6360

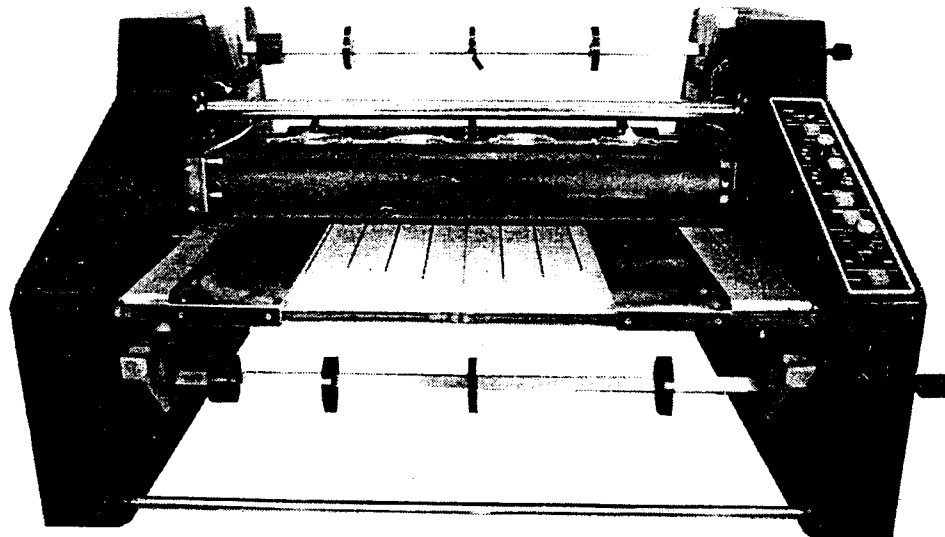

GBC

General Binding Corporation

One GBC Plaza
Northbrook, Illinois 60062
312/272-3700

PART NO. 1119907
REV. 2 (10/88)
T.J.H 3-03-04

4.0 OPERATING INSTRUCTIONS

Your new GBC Laminator is a durable, simple to operate machine designed for heavy work loads. By following these instructions and taking proper care of your unit, you can be assured of years of professional quality laminating.

These instructions cover two models of laminators; the GBC 6250 and GBC 6360. Aside from the width, both units appear and operate alike.

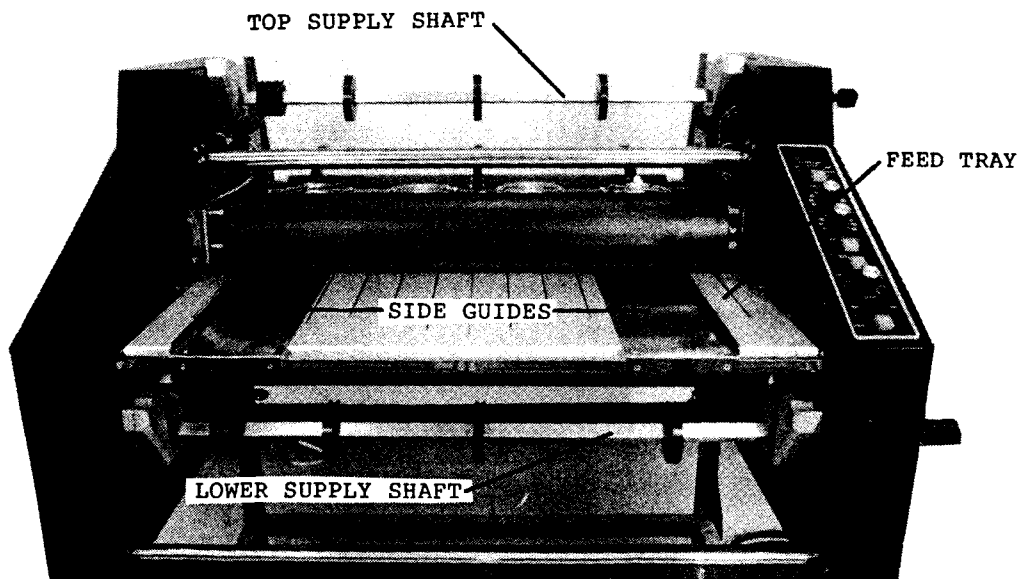
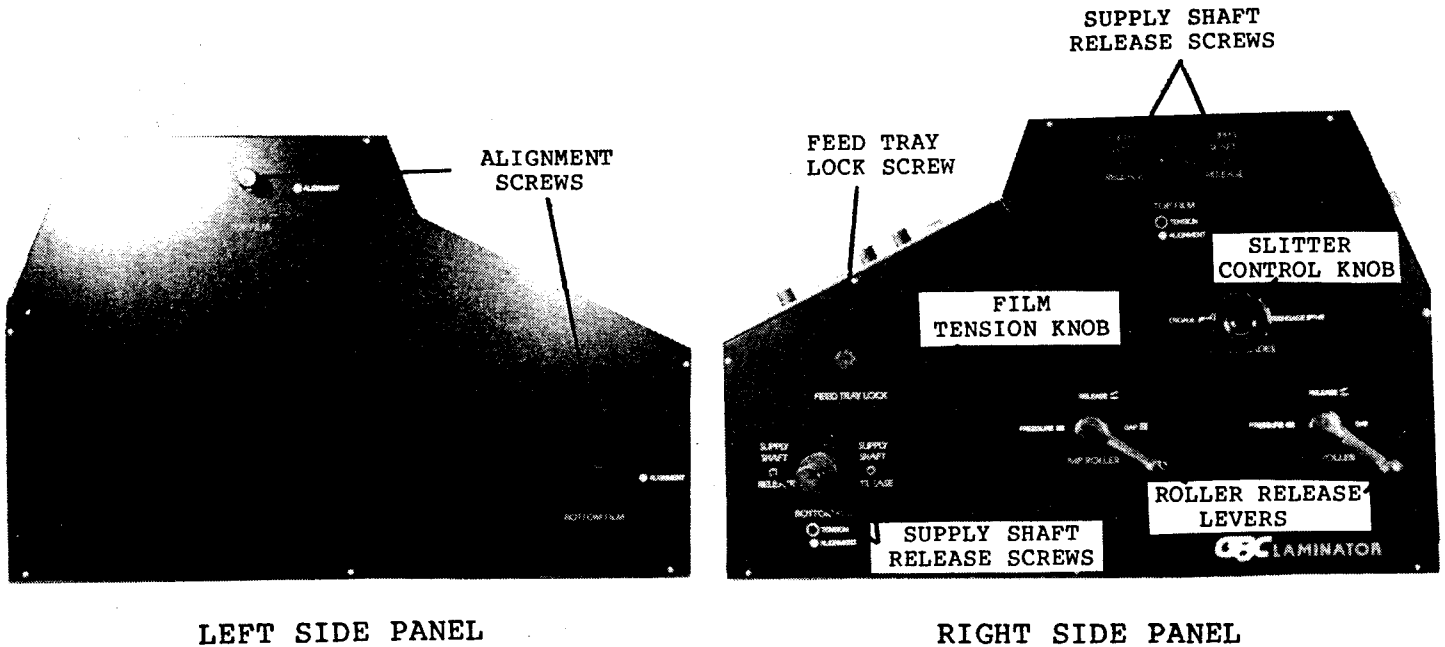

Figure 4.0.1

4.0 OPERATING INSTRUCTIONS (Continued)

4.1 Loading and Threading Film

WARNING: If the laminator has been in recent use, the top and bottom heaters will be hot. To avoid burns due to contact, allow to cool before proceeding.

NOTE: It is recommended that both rolls of film be changed at the same time. This should be done when the "WARNING END OF ROLL" label on either of the film rolls has passed through the laminator.

The laminators use NAPLAM film that has the adhesive side of the film rolled to the outside of the roll (designated "poly-out"). Proper loading and threading of this film is necessary for good quality lamination

- 1) Loosen the feed tray lock screw and lift the feed tray from the laminator. See figure 4.0.1.
- 2) Cut the film passing through the laminator from the film supply roll. Move both roller release levers (See figure 4.0.1) to the "GAP" position and remove the film web from the laminator by pulling out the front.
- 3) Back off the two alignment screws (located on the left side panel) until they are at least 1/4" from the supply shafts.
- 4) Loosen the four (4) supply shaft release screws (See figure 4.0.1) until they come free. Firmly grasp each film tension knob (located on the right side panel) and pull outward until it disengages from the supply shaft.
- 5) Remove the bottom supply shaft by lifting the shaft straight up and then towards you, clear of the laminator housing. Place it on the floor in front of the laminator as it was removed. Remove the old film core from the shaft.
- 6) Place the new film roll on the shaft so that the film unwinds from the top of the film roll toward the heat shoes of the laminator. See figure 4.1.1.

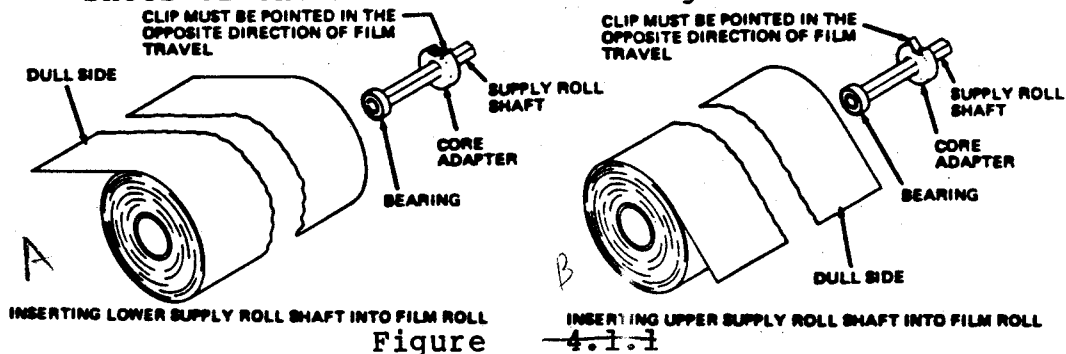

4.0 OPERATING INSTRUCTIONS (Continued)

4.1 Loading and Threading Film (Continued)

- 13) Align the top and bottom film rolls with a tape measure or ruler so that they are positioned approximately the same distance from the left side frame. See figure 4.1.3. Improper edge alignment of film webs will allow adhesive to transfer onto rollers and heaters. If this occurs, clean immediately.

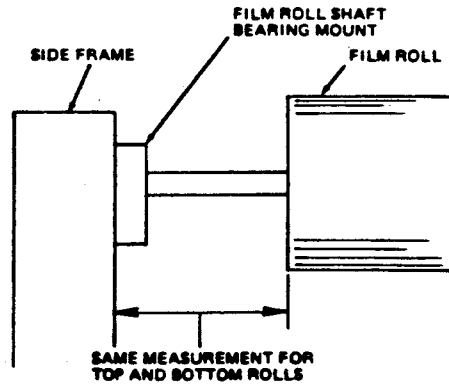

Figure

4-6
4.1.3

- 14) Unwind about 3 feet (91 cm) of film, from the bottom roll, and pass the loose end under the lower film idler, upward over the tie bar, and back over the top of the lower film roll (See Figure 4.1.4).
- 15) Unwind about 3 feet (91 cm) of film, from the top roll, and pass the loose end under the top film idler and over the top of the lower film roll (See Figure 4.1.4).

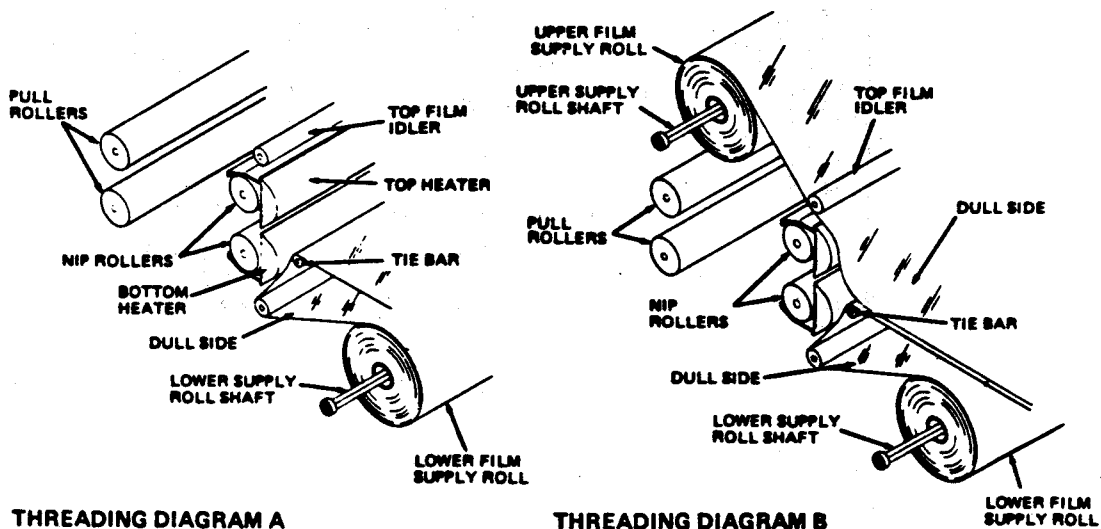

THREADING DIAGRAM A

THREADING DIAGRAM B

Figure

~~4.1.4~~

4.0 OPERATING INSTRUCTIONS (Continued)

4.1 Loading and Threading Film (Continued)

- 7) Place the loaded lower supply shaft into the laminator as it was removed.
- 8) Remove the top supply shaft by lifting the shaft straight up and towards the rear of the laminator. Place it on the floor behind laminator as it was removed. Remove the old film core from the shaft.
- 9) Place the new film roll on the shaft so that the film unwinds from the top of the film roll toward the back of the laminator. See figure 4.1.1.
- 10) Place the loaded top supply shaft into the laminator as it was removed.
- 11) Slide both the top and bottom supply shafts towards the right side panel where the film tension knob is located. Grasp the respective film tension control knob and move it so that the brake hub is aligned with the end of the respective supply shaft. Rotate the supply shaft so that the "groove" in it's right end aligns with the "key way" in the brake hub. See figure 4.1.2. Slide the brake hub onto the supply shaft as far as possible.

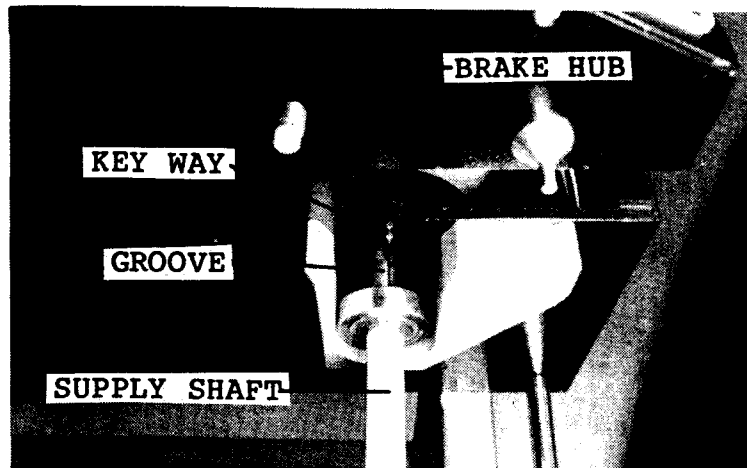

Figure ~~4.1.2~~

4-5

- 12) Lock the brake mechanism in place by pushing the supply shaft release screws into position and turning them clockwise until they stop.

4.0 OPERATING INSTRUCTIONS (Continued)

4.1 Loading and Threading Film (Continued)

- 16) With a piece of cardboard at least 24" (61 cm) long, make 1-1/2 folds in the film as shown in figure 4.1.5. Push the cardboard between the two nip rollers. Move both front and rear roller release levers to "CLOSED" position. Run the motor at a slow speed (refer to section 4.6 "Laminator Start-up Procedure") and allow the motor to pull the cardboard and film completely through the laminator. Stop the laminator when film is threaded.

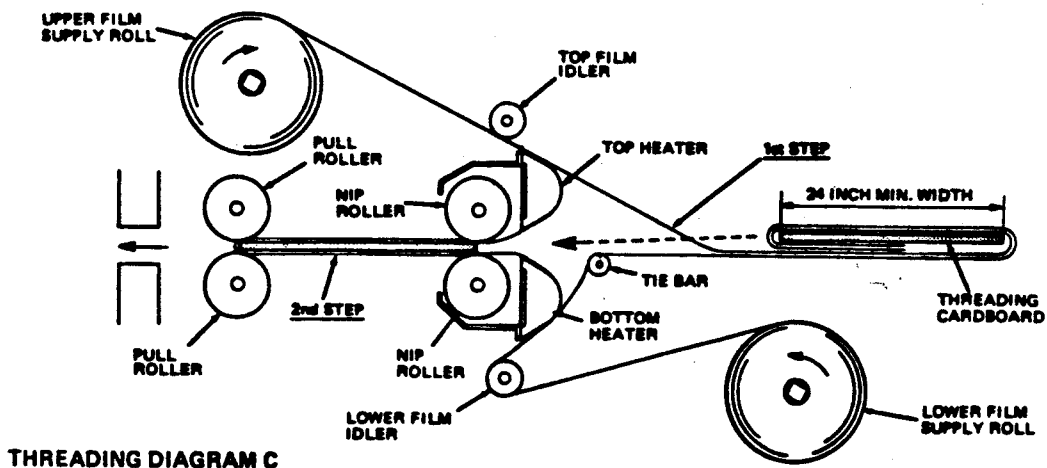

Figure ~~4.1.5~~ 4-8

- 17) Check the alignment of the film webs. Use the film alignment screws to move the supply shafts until the edges of the film align. Before operating the laminator, rotate the film alignment screws two (2) turns counter clockwise so that they do not touch the ends of the supply shafts. Tighten the two left hand locknuts to secure the shaft alignment screws.
- 18) Install the feed table and tighten the feed table lock screw to position the table.

4.2 Film Roll Tension Adjustment

Proper film roll tension allows for the easy unwinding of the film supply roll and eliminates wrinkles in the finished lamination. This adjustment should be made whenever a new size or gauge of film is used. To adjust film roll tension, run the laminator at the speed and heat settings that you will be using. Rotate the film tension control knobs, on the right side panel, clockwise until bubbles or wrinkles in the film are removed as the film passes over the nose of the

4.0 OPERATING INSTRUCTIONS (CONTINUED)

4.2 Film Roll Tension Adjustment (Continued)

heat shoe. The minimum possible tension should always be used to prevent film stretch. As the roll of film gets smaller, it is necessary to gradually reduce the amount of film tension by rotating the film tension control knobs counter clockwise.

Film tension can be checked by inspecting the film web exiting the laminator. Too little tension will causes wrinkles in the film. Too much tension will causes the film to stretch and become narrower. Unequal tension between the top and bottom rolls, results in a curled lamination. (If the product curls up, there is greater tension on the top roll, and vice versa.)

4.3 Side Slitter Blade Adjustment and Installation

WARNING: THE BLADES ARE VERY SHARP, EXTREME CAUTION MUST BE EXERCISED.

When a slitter adjustment is made, the slitter blades should be disengaged by rotating the slitter control knob to the disengaged position. See figure 4.0.1. To adjust the slitters, loosen the two knurled thumb screws, on the blade holder, and move the blade holder in the direction required. Tighten the two knurled thumb screws to lock the blade holder in position.

To install a new blade, rotate the slitter control knob to the "engage" position (blades down). Loosen the three (3) phillips head screws that secure the clamp plate to the slitter blade holder and remove the blade by pulling straight down.

Insert the new blade with the cutting edge toward the front of the machine. Each blade must be installed to the same depth within the three slitter assemblies. Tighten the three (3) phillips head screws alternately to avoid any binding in the assembly and insure even pressure on blade.

4.4 Side Guide Adjustment

The side guides on the feed table allow the item(s) being laminated to be inserted parallel to the film path. Proper guide positioning allows accurate, consistent feeding and side slitter trimming. Loosening the thumb screws permits the guides to be moved across the feed table surface and locked in the desired position.

4.0 OPERATING INSTRUCTIONS (Continued)

4.5 Roller Pressure Adjustment

The laminator is factory set to accept work up to 1/16" (1.83 mm) without adjustment. To laminate product between 1/16" (1.83 mm) and 1/4" (6.25 mm) the roller pressure must be adjusted. For this purpose each laminator comes equipped with roller pressure adjusting wheels and labels located directly above both sets of rollers. (See Figure 4.5.1).

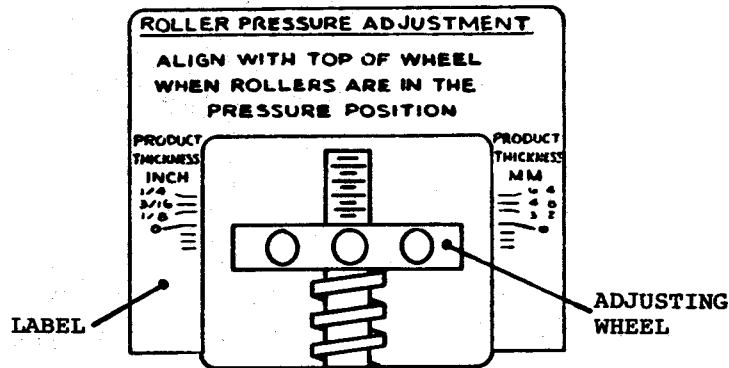

To adjust roller pressure for product over 1/16" thick rotate both roller release levers to the "Pressure" position. Using a tool such as an allen wrench, rotate the roller pressure adjusting wheel until its top surface aligns with the desired product thickness line marked on the adjustment label. This adjustment must be made at all four (4) roller pressure adjustment locations.

When product of 1/16" or less is run, the roller pressure adjustment wheel must be adjusted so that its top surface aligns with the zero (0) product thickness mark on the adjustment label.

4.6 Laminator Start-Up Procedure

1. Turn both roller release levers on the right end panel of the laminator, clockwise to the "GAP" position.
2. Press the Power switch to turn the laminator on. See figure 4.6.1.
3. Set motor speed dial to 5 ft./min. (1.5 m/min.). Turn the Motor switch to the FWD (forward) position.
4. Set both top and bottom heaters dials to 300 F (149 C). Press both heater buttons ON (amber buttons will illuminate to indicate when heaters are ON).

4.0 OPERATING INSTRUCTIONS (Continued)

4.6 Laminator Start-up Procedure (Continued)

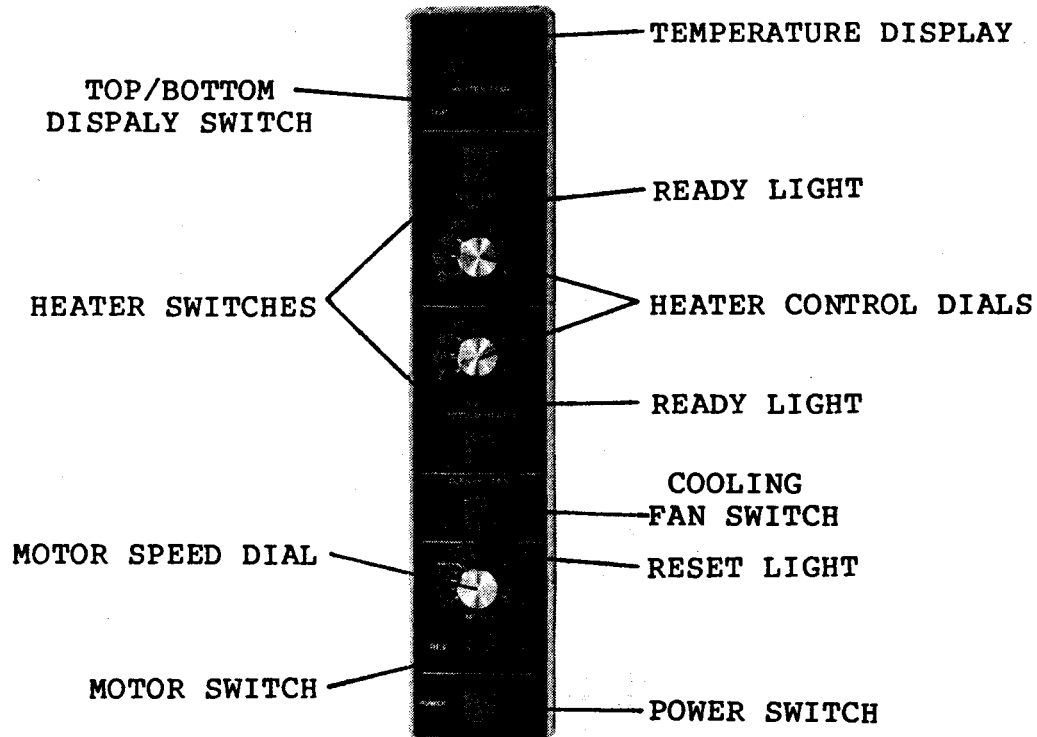

5. Allow approximately 15-20 minutes for entire system to pre-heat to operational temperature. When the system has reached operational temperature, the "Ready" light for both heaters will illuminate.
6. Adjust temperature controls to desired temperature. Allow three (3) minutes for laminator to stabilize after each adjustment.
7. Press the cooling fans button to ON. The amber button will illuminate and the fans will operate.
8. Place the Motor switch in the off (center) position. Rotate the roller pressure handles to Pressure position. Set the motor speed dial to the desired running speed. Place the Motor switch in the "FWD" (forward) position.
9. Place a test sample of material to be laminated on the feed table and slide it into the laminator until it is "grabbed" by the rollers. Release the sample and allow it to be pulled through the laminator until it exits the rear of machine. Turn the motor switch OFF. Remove the sample by using the cross cutter on the back of the laminator.

4.0 OPERATING INSTRUCTIONS (Continued)

4.6 Laminator Start-up Procedure (Continued)

10. Examine and test the sample for complete lamination by placing the sample on a flat surface and making a small "X" cut through the layer of laminating film and trying to pull the film away from the sample. A good lamination is indicated if the film pulls off the fibers of the paper or lifts off the ink from the paper's surface.

4.7 Operating Hints

1. Always run a sample to test for proper performance (preferably of the same type and weight as the actual document or product).
2. Do not force materials between the rollers. The laminator will work successfully on materials up to 1/4" (6.35 mm) with laminating film as thick as 10 mil (.254 mm) on both sides.
3. Always leave rollers gapped when laminator is not in use for long periods of time. When restarting the laminator after a shutdown, always make sure that both layers of laminating film are completely threaded through the unit.
4. Feed the document slowly and evenly into the rollers, once it engages the nip rollers, release the document entirely.
5. Never stop the unit with a document or product in process. If the unit is stopped, the rollers will impress a permanent mark across the laminated surface.
6. If a document cannot be laminated because of unusual surface finish, it may be encapsulated. That is, leave at least a 1/8" (3.18 mm) film border surrounding it.