

5160X/6160X  
PARTS LIST  
FIGURE 8.1

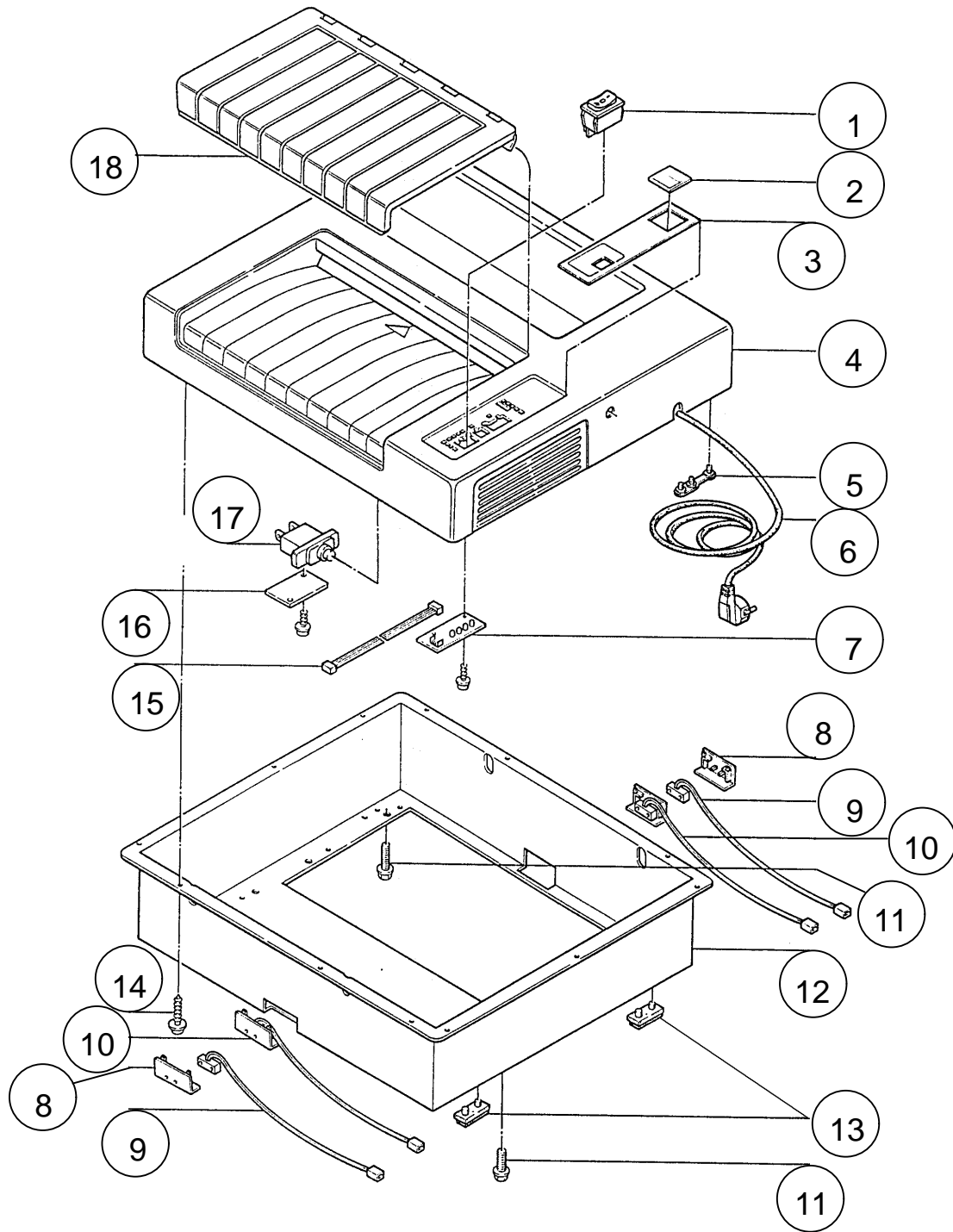

**5160X/6160X**  
**PARTS LIST**  
**FIGURE 8.1**

<b>ITEM</b>	<b>PART No.</b>	<b>DESCRIPTION</b>	<b>QTY</b>
1	1751534	Switch	1
2	1751503	Label	1
3	1751498	Control Panel Label	1
4	1751443	Housing	1
5	1751484	Strain Relief, Complete	1
6	1751496	Power Cord	1
7	1751442	PC Board	1
8	1751432	Cover	2
9	1751542	Reed Contact	2
10	1751434	Switch, Complete	2
11	1751518	Screw	6
12	1751459	Base Plate, Complete	1
13	1751526	Rubber Foot	4
14	1751538	Screw with Washer	12
15	1751504	Ribbon Cable	1
16	1751477	Overload Bracket	1
17	1751499	Overload Protection 15A	1
18	1751495	Sound Cover	1

**5160X6160X**  
**PARTS LIST**  
**FIGURE 8.2**

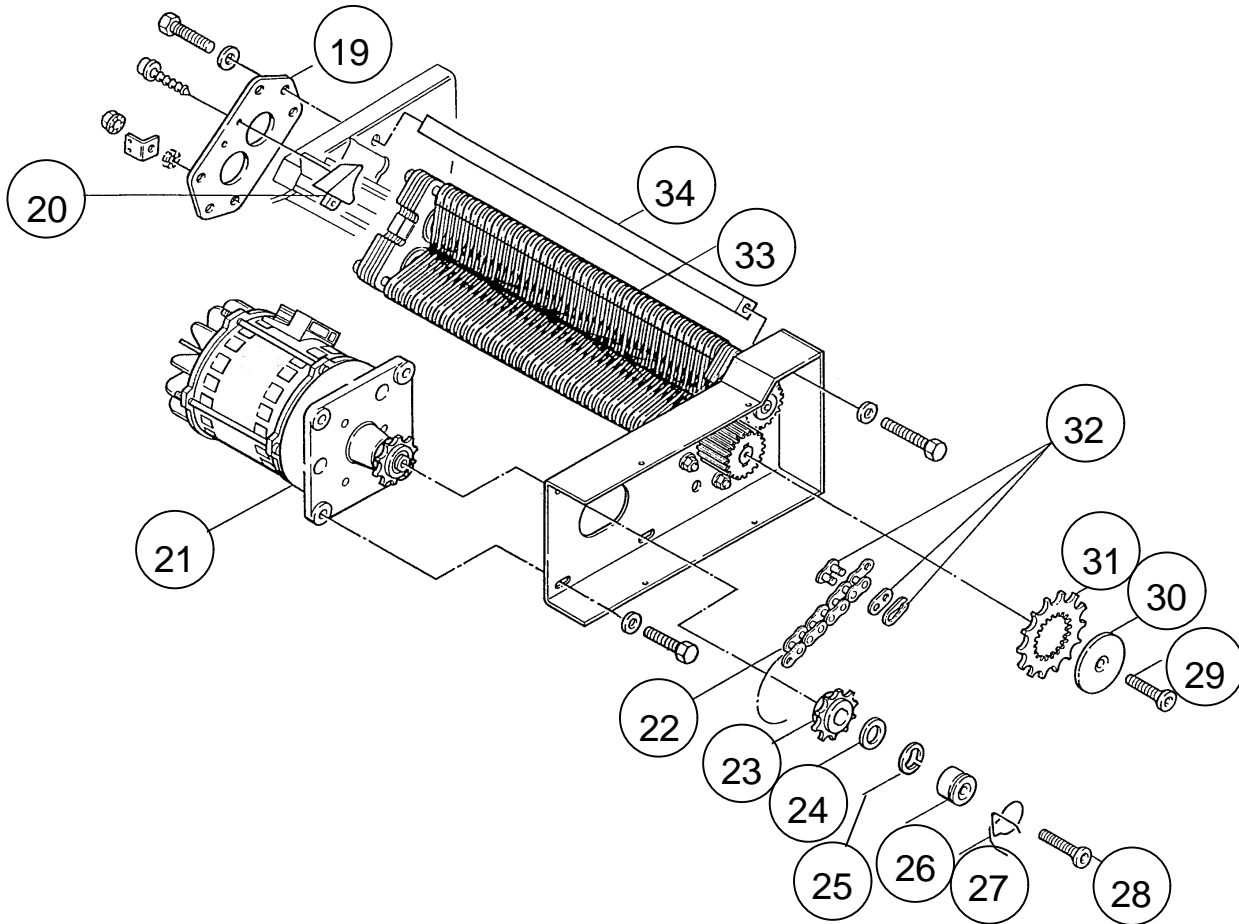

ITEM	PART No.	DESCRIPTION	QTY
19	1751492	Bracket	1
20	1751532	LH Deflector	1
21	1751449	Gear Motor, 115V	1
22	1751489	Chain	1
23	1751435	Motor Sprocket	1
24	1751533	Spacer	1
25	1751546	Clip	1
26	1751472	Washer	1
27	1751476	Cut out spring	1
28	1751519	Screw	1
29	1751523	Screw	1
30	1751493	Cover Disk	1
31	1751467	Sprocket	1
32	1751514	Master Link	1
33	1751507	Complete Cutting Head	1
34	1751478	Supporting Lever	2

5160X/6160X  
PARTS LIST  
FIGURE 8.3

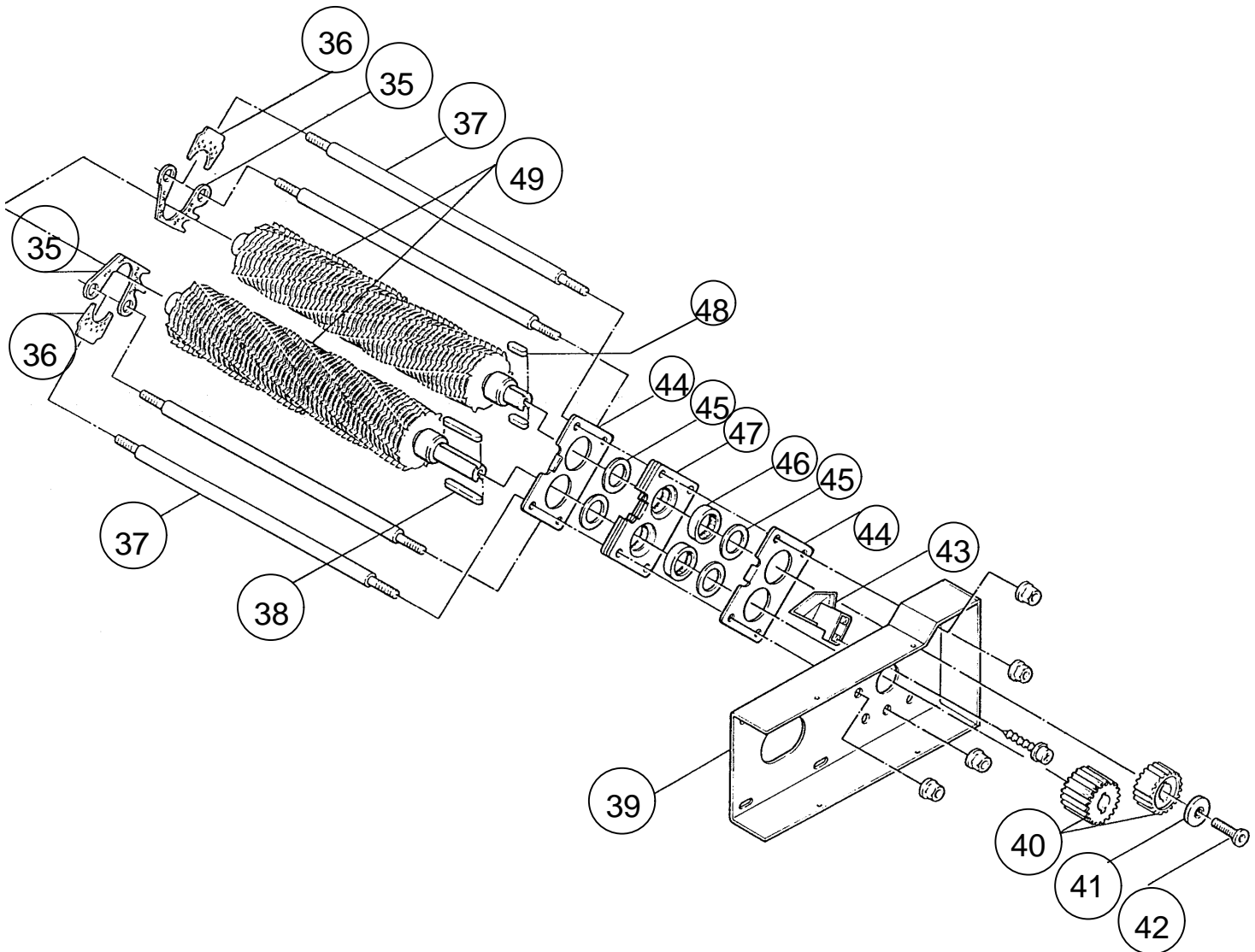

ITEM	PART No.	DESCRIPTION	QTY
35	1751473	Separator	100
36	1751474	Filler	200
37	1751468	Bar	4
38	1751548	Key	2
39	1751475	Motor Bracket	1
40	1751483	Z - 20 Gear Set	1
41	1751515	Cover Washer	1
42	1751523	Screw	1
43	1751535	RH Deflector	1
44	1751469	Cover	8
45	1751544	Washer	16
46	1751543	Bushing	8
47	1751482	Side Plate, Complete	2
48	1751527	Key	4
49	1751488	Knife Shaft Set, 4 X 60 MM	1

5160X/6160X  
**PARTS LIST**  
**FIGURE 8.4**

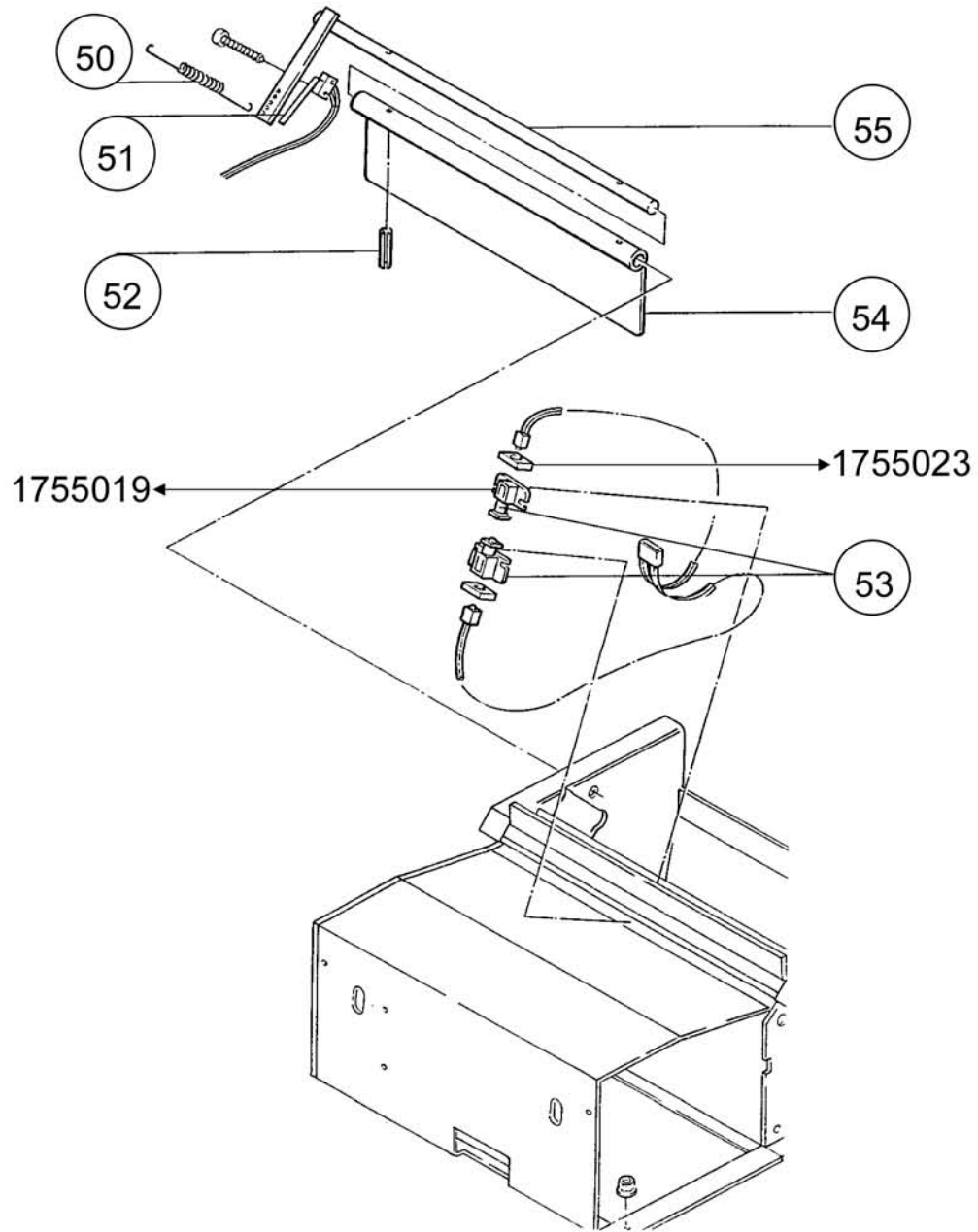

ITEM	PART No.	DESCRIPTION	QTY
50	1751529	Tension Spring	1
51	1751487	Micro Switch, Complete	1
52	1751512	Pin	2
53	1751433	Emitter and Receiver, Complete	1
54	1751453	Bag Full Sensor Plate	1
55	1751454	Axle, Complete	1

5160X/6160X  
PARTS LIST  
FIGURE 8.5

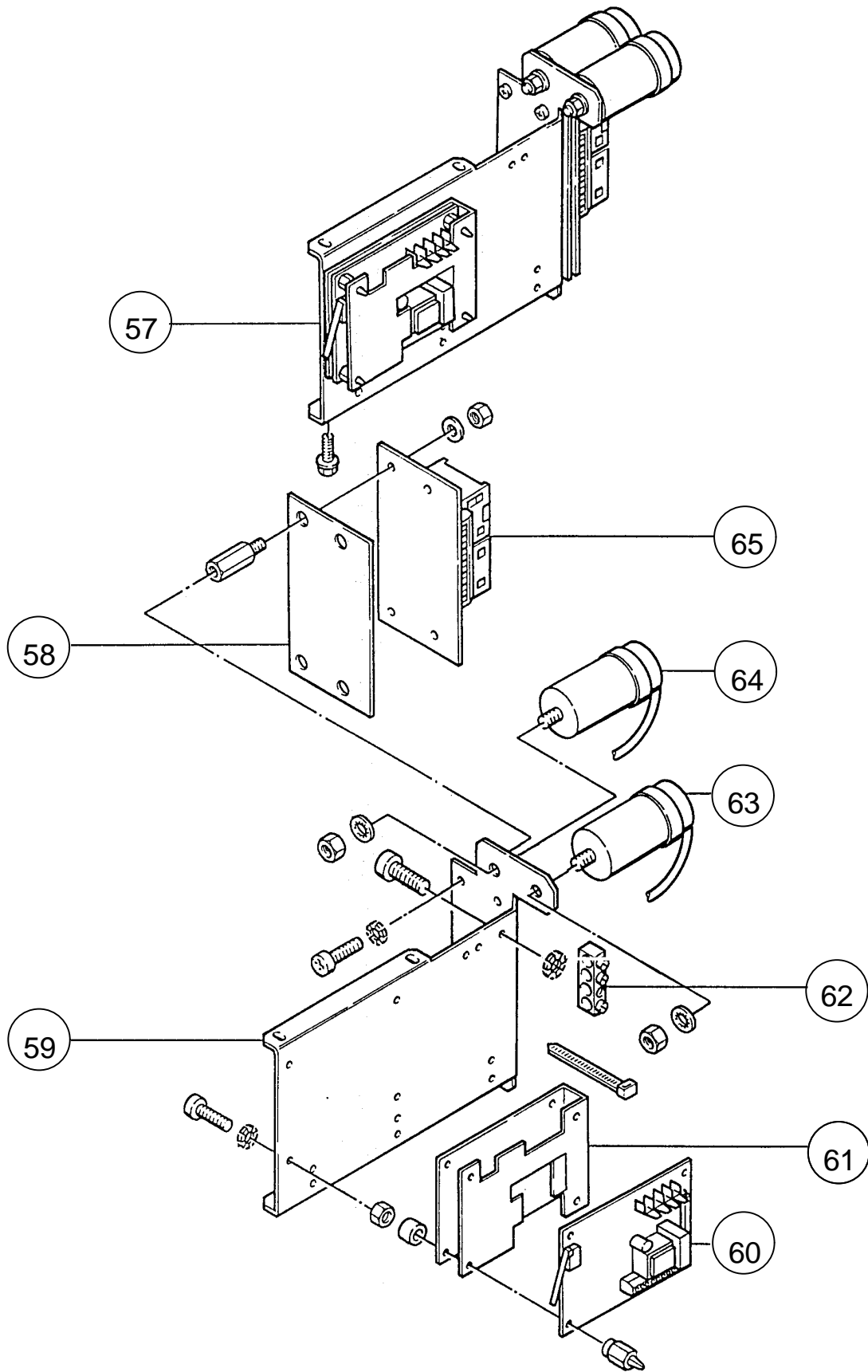

**5160X/6160X**  
**PARTS LIST**  
**FIGURE 8.5**



<b>ITEM</b>	<b>PART No.</b>	<b>DESCRIPTION</b>	<b>QTY</b>
57	1751452	Electronic, Complete Mounted 115V	1
58	1751437	Insulation	1
59	1751457	Electronic Bracket	1
60	1751448	Control Board, 115V	1
61	1751438	Electronic Cover, Complete	1
62	1751549	Terminal Block	1
63	1751485	Capacitor 100/115V	1
64	1751479	Capacitor 100/115V	1
65	1751439	Contactator B 12, 115V	2

5160X/6160X  
**PARTS LIST**  
**FIGURE 8.6**

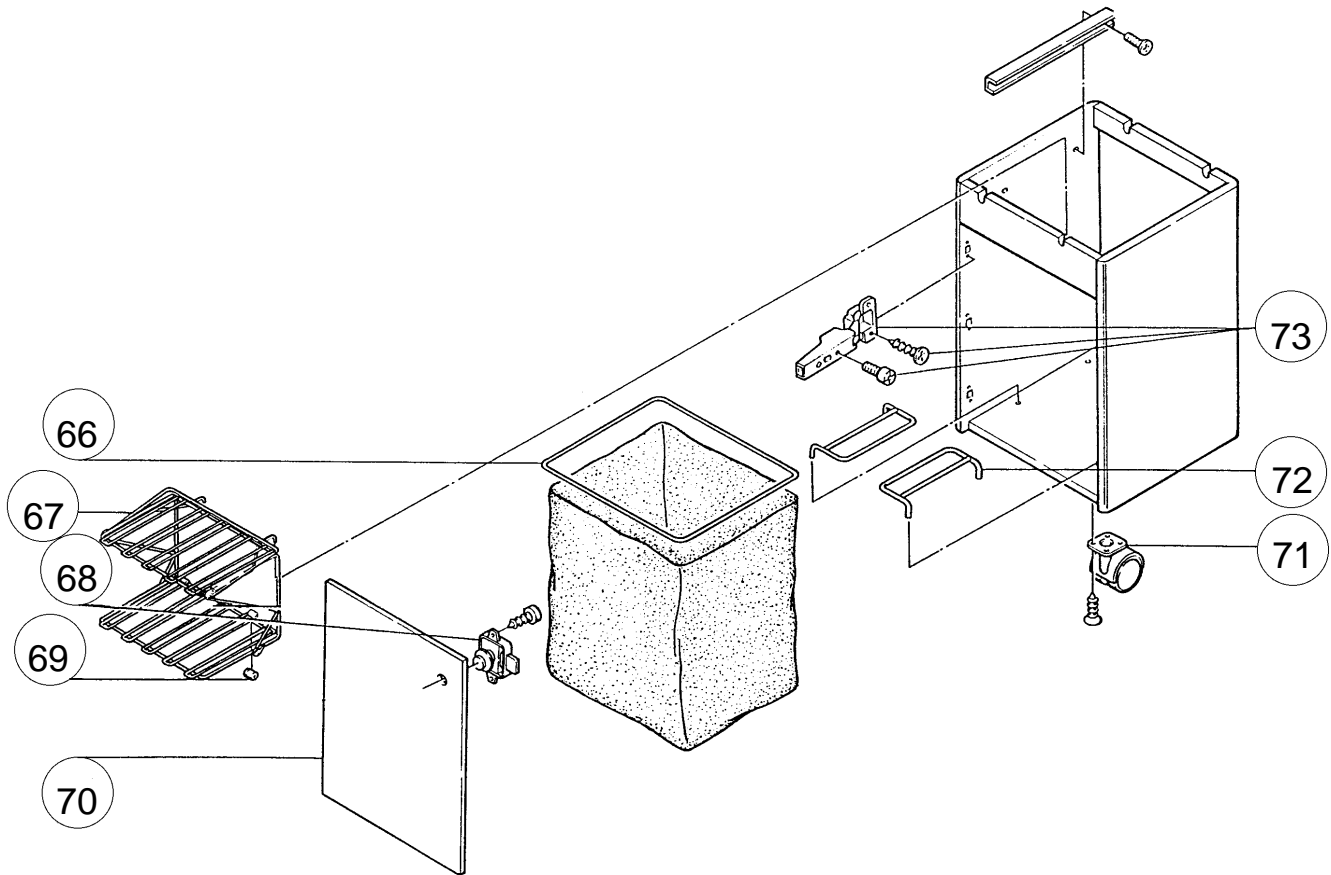

ITEM	PART No.	DESCRIPTION	QTY
66	1751464	Bag Holder	1
67	1751494	EDP Rack	1
68	1751522	Pressure Lock, Complete	1
69	1751525	Rubber Sleeve	2
70	1751466	Door	1
71	1751537	Roll	4
72	1751465	Assembly	2
73	1751545	Hinge, Complete	3

---

<b>Part No.</b>	<b>Description</b>	<b>Trunk Inventory</b>
1751534	Switch	1
1751542	Reed Contact	2
1751489	Chain	1
1751483	Z - 20 Gear Set	1
1751433	Emitter and Receiver, Complete	1
1751439	Contact B 12, 115V	2
1751448	Control Board, 115V	1

\* Based on 100 units.