



425LM PARTS LIST



GBC IS AN ACCO BRANDS COMPANY

FIGURE 4. GBC MODELS 425-LM AND 426-LM LAMINATORS

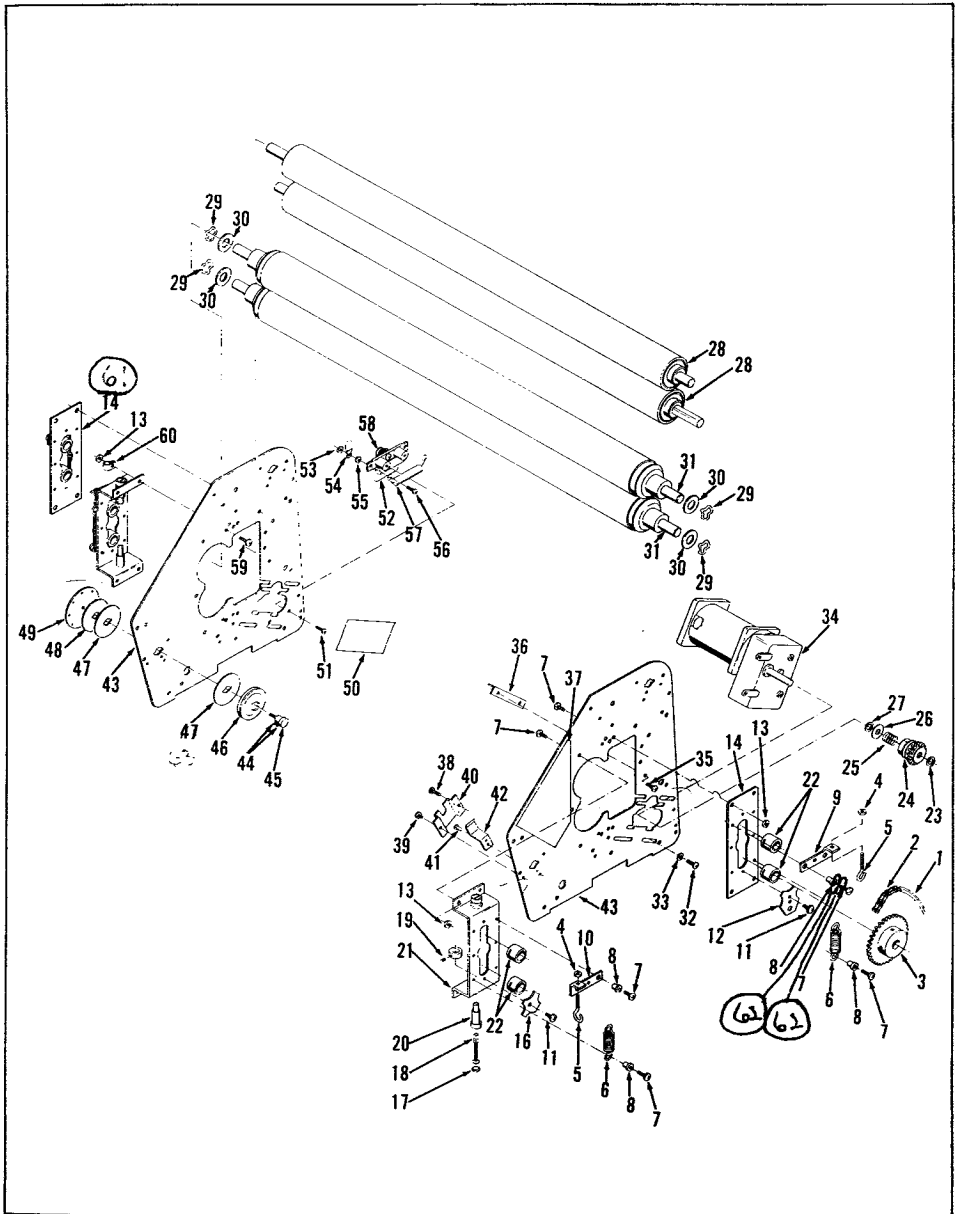

FIGURE 8.1

INDEX NUMBER	PART NUMBER	PART NAME	QUANTITY	
			425-LM	426-LM
1	1107407	KNOB.	1	1
2	1107408	SLEEVE.	1	1
3	1926604	NUT, HEX 5/16 - 18.	1	1
4	1903003	SCREW, M.S.T.H.C.R., 8-32 X 3/8" LG.	6	6
5	1103667	NUT, SPEED.	2	2
6	1122061	COVER ASSEMBLY, RIGHT HAND.	1	1
7	1122064	COVER ASSEMBLY, LEFT HAND.	1	1
8	1900004	SCREW, S.S.S.H., 10-32 X 1/4" LG.	2	2
9	1102205	DISC ASSEMBLY, SUPPLY ROLL.	4	4
10	1902815	SCREW, M.S.P.H.C.R., 6-32 X 1/2" LG.	6	6
11	1925802	WASHER, LOCK, INTERNAL TOOTH, NO. 6.	6	6
12	1102346	CLIP, CORE MOUNTING.	6	6
13	1925007	WASHER, FLAT METAL, NO. 6.	24	24
14	1109341	ROD, ROLL CARRIER.	2	2
15	1106164	KNOB.	2	2
16	1128642	GUIDE ASSEMBLY, SIDE.	1	1
17	1106163	SCREW, KNOB.	2	2
18	1106160	LABEL, THREADING DIAGRAM.	1	1
19	1109323	LABEL, NORMAL SPEED SETTING.	1	1
20	1128546	LABEL, LOGO.	1	1
21	1109354	TRAY, FEED TABLE.	1	1
22	1105157	KNOB, SPEED CONTROL.	1	1
23	1109407	SWITCH ASSEMBLY, SPEED CONTROL.	1	1
24	1105158	LIGHT, "ON/READY".	1	
24	1105308	LIGHT, "ON/READY".		1
25	1902803	SCREW, M.S.P.H.C.R., 6-32 X 1/4" LG.	4	4
26	1926801	NUT, HEX, KEPS, 6-32.	4	4
27	1109324	PANEL, CONTROL.	1	1
28	1907801	SCREW, T.C.S.P.H.C.R., 6-32 X 3/8" LG.	2	2
29	1108169	SWITCH, CONTROL.	1	1
30	1911105	SCREW, M.S.P.H.C.R., SEMS, 8-32 X 1/4" LG.	2	2
31	1105159	BRACKET, PANEL.	1	1
32	1902908	SCREW, M.S.R.H.C.R., 10-32 X 7/8" LG.	4	4
33	1927202	NUT, FLEX-LOCK, 10-32.	4	4
34	1122032	SUPPORT, TABLE.	4	4
35	1105141	O-RING, SPACER, TABLE.	2	2
36	1911107	SCREW, M.S.P.H.C.R., SEMS, 10-32 X 5/8" LG.	4	4
37	1108054	BEARING, SHAFT, FILM GUIDE.	4	4
38	1109343	TUBE, FILM GUIDE.	2	2
39	1109342	SHAFT, FILM GUIDE.	2	2
40	1907806	SCREW, T.C.S.P.H.C.R., 8-32 X 3/4" LG.	14	14
41	1925806	WASHER, LOCK, INTERNAL TOOTH, NO. 8.	14	14
42	1929601	RIVET, PLASTIC.	2	2
43	4811580	BINDING, CERLOX 3/16 WB, 19R.	1	1
44	1911109	SCREW, M.S.P.H.C.R., SEMS 6-32 X 1/4" LG.	8	8
45	1103631	BLADE, TEAR-OFF.	2	2

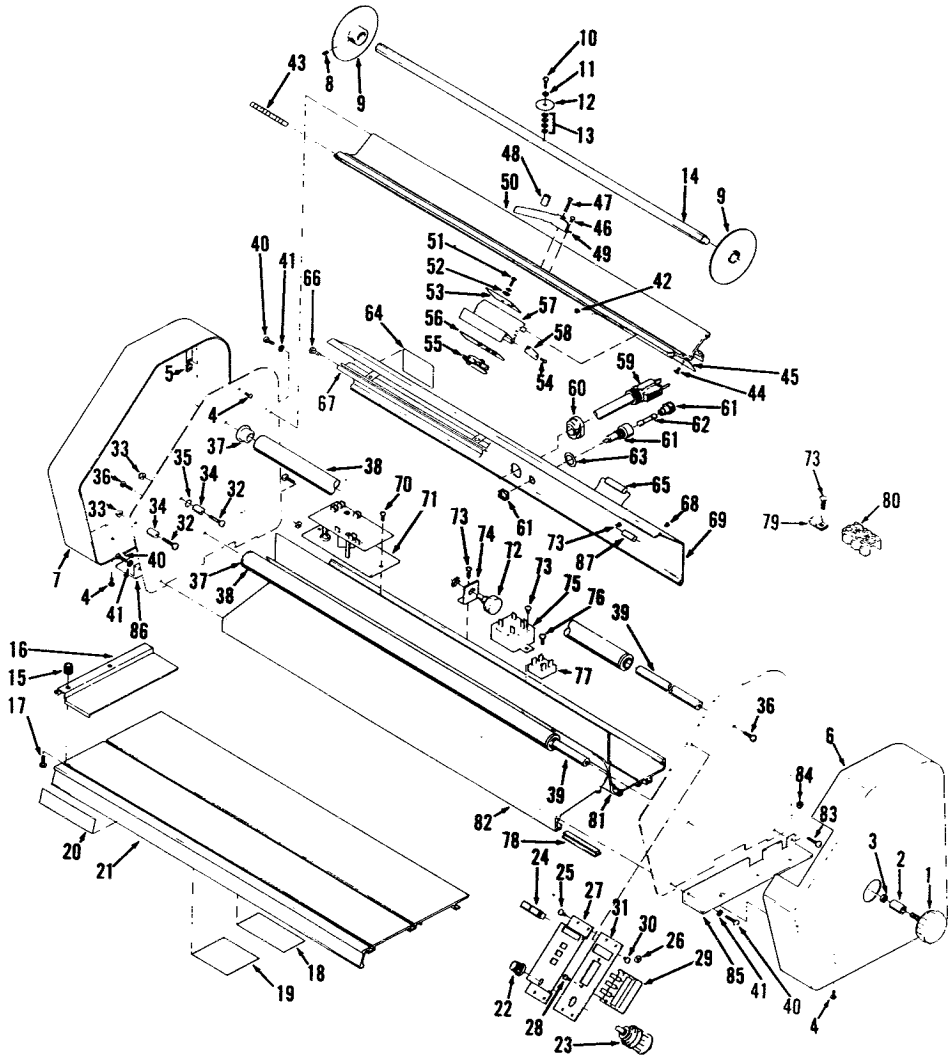

FIGURE 8.1 (Continued)

INDEX NUMBER	PART NUMBER	PART NAME	QUANTITY	
			425-LM	426-LM
46	1911119	SCREW, M.S.P.H.C.R., SEMS, 6-32 X 3/4" LG	1	1
47	1911113	SCREW, M.S.P.H.C.R., SEMS, 6-32 X 3/16" LG.	1	1
48	1109456	SPACER	1	1
49	1109455	SPRING, THERMOSTAT HOLD-DOWN	1	1
50	1109364	PANEL, CUT-OFF	1	1
51	1911111	SCREW, M.S.P.H.C.R., SEMS, 8-32 X 1/2" LG	1	1
52	1925004	WASHER, FLAT, NO. 8.	1	1
53	1104321	PLATE, THERMOSTAT INSTRUCTION.	1	1
54	1907812	SCREW, T.C.S.P.H.C.R., 4-40 X 1/4" LG.	4	4
55	1109373	THERMOSTAT, HEAT CONTROL	1	1
56	1109368	SPACER, THERMOSTAT, PHENOLIC	1	1
57	1109366	GUARD, THERMOSTAT.	1	1
58	1109367	COVER, END, THERMOSTAT GUARD	2	2
59	1109386	CORD, POWER SUPPLY	1	
59	1128681	CORD, POWER SUPPLY		1
60	1952404	RELIEF, STRAIN	1	
60	1952414	RELIEF, STRAIN		1
61	1105849	HOLDER, FUSE	1	1
62	1104289	FUSE, 250V, 15 AMP	1	
62	1102211	FUSE, 250V, 8 AMP		1
63	1105550	LABEL, ELECTRICAL IDENTIFICATION	1	
63	1105553	LABEL, ELECTRICAL IDENTIFICATION		1
64	1128553	NAMEPLATE, STAMPED	1	
64	1109393	NAMEPLATE, STAMPED		1
65	1109440	MOTOR TRANSIENT VOLTAGE SUPPRESSION ASSEMBLY	1	
65	1109441	MOTOR TRANSIENT VOLTAGE SUPPRESSION ASSEMBLY		1
66	1907806	SCREW, THREAD CUTTING, 8-32 X 3/4" LG.	2	2
67	1131014	STATIC ELIMINATOR AND FILM HOLD-DOWN	1	1
68	1911109	SCREW, M.S.P.H.C.R., SEMS, 6-32 X 3/8" LG	4	4
69	1109361	COVER, REAR.	1	1
70	1911116	SCREW, M.S.P.H.C.R., SEMS, 6-32 X 3/8" LG	2	2
71	1109405	HEAT CONTROL, SOLID STATE.	1	
71	1109406	HEAT CONTROL, SOLID STATE.		1
72	1109454	POTENTIOMETER AND LEAD ASSEMBLY.	1	1
73	1911115	SCREW, M.S.P.H.C.R., SEMS, 6-32 X 5/16" LG.	4	6
74	1109452	ANGLE, POTENTIOMETER MOUNTING.	1	1
75	1109410	SPEED CONTROL, SOLID STATE	1	
75	1109411	SPEED CONTROL, SOLID STATE		1
76	1911110	SCREW, M.S.P.H.C.R., SEMS, 6-32 X 5/8" LG		1
77	1105857	RECTIFIER, SILICON	1	1
78	1107289	FOOT, RUBBER	4	4

FIGURE 8.1 (Continued)

INDEX NUMBER	PART NUMBER	PART NAME	QUANTITY	
			425-LM	426-LM
79	1128672	CLAMP, CABLE		1
80	1128734	BLOCK, TERMINAL.		1
81	1109358	PLATE, BASE, REAR.	1	1
82	1109356	PLATE, BASE, FRONT	1	1
83	1902820	SCREW, M.S.P.H.C.R., 10-32 X 1/2" LG	2	2
84	1926803	NUT, HEX, KEPS, 10-32.	2	2
85	1109351	ANGLE, RIGHT	1	1
86	1109350	ANGLE, LEFT.	1	1
87	1109463	RESISTOR ASSEMBLY.		1

FIGURE 4. GBC MODELS 425-LM AND 426-LM LAMINATORS (Cont'd)

*Denotes Electrical and/or Mechanical Component Change Required for Model 426-LM Laminator 230 VAC, 50 Hz.

Index Number	Part Number	Part Name	Quantity
58	1103039	THERMOSTAT, READY LIGHT CONTROL	1
59	1911123	SCREW, M.S.P.H.C.R., SEMS, 10-32 x 1/4"	1
60	1931003	CLAMP, CABLE	2
*Denotes Electrical and/or Mechanical Component Change Required for Model 426-LM Laminator 230 VAC 50 Hz			
*34	1109467	MOTOR AND LEAD ASSEMBLY	1
*52	1106106	THERMOSTAT ASSEMBLY	1
*57	1106105	RESISTOR	1

61 112200 SEALS Pull Roll BEARING, LEFT 1

62 1925003 WASHER, FLAT 4

FIGURE 4. GBC MODELS 425-LM AND 426-LM LAMINATORS

* Denotes Electrical and/or Mechanical Component Change Required for Model 426-LM Laminator 230 VAC, 50 Hz.

Index Number	Part Number	Part Name	Quantity
1	1128691	CHAIN, 25/4 PITCH	1
2	1102260	LINK, MASTER	1
3	1109370	SPROCKET	1
4	1926802	NUT, HEX, KEPS, 8-32	4
5	1953801	EYEBOLT	4
6	1102275	SPRING, BEARING BRACKET	4
7	1902913	SCREW, M.S.R.H.C.R., 10-32 x 7/16"	16
8	1932401	PERMA-NUT, 10-32	8
9	1102276	LEVER, RIGHT HAND	2
10	1102277	LEVER, LEFT HAND	2
11	1911123	SCREW, M.S.P.H.C.R., SEMS, 10-32 x 1/4"	3
12	1122011	PLATE, GAP AND PULL ROLL ADJUSTMENT	2
13	1926803	NUT, HEX, KEPS, 10-32	8
14	1128641	PLATE, PULL ROLL BEARING, <i>RIGHT</i>	2
16	1122010	PLATE, LOWER HEAT ROLL ADJUSTMENT	2
17	1102234	CAP, BRUSH HOLDER	4
18	1102231	BRUSH AND SPRING ASSEMBLY	4
19	1900008	SCREW, S.S.S.H., 6-32 x 1/8"	4
20	1102232	HOLDER, BRUSH	4
21	1122015	HEAT ROLL BEARING BRACKET ASSEMBLY	2
22	1102218	BEARING	8
23	1931606	GRIPRING	1
24	1106167	CLUTCH ASSEMBLY	1
25	1100107	SPRING	1
26	1925125	WASHER, FLAT, METAL, 21/64" I.D.	1
27	1925001	WASHER, FLAT, METAL, 5/16	2
28	1109337	PULL ROLL ASSEMBLY	2
29	1926504	SPRING WASHER, WAVY, 1/2	4
30	1104287	WASHER, NON-METALIC	4
31	1109330	HEAT ROLL ASSEMBLY	2
32	1911103	SCREW, M.S.P.H.C.R., SEMS, 10-32 x 1/2"	3
33	1925002	WASHER, FLAT, METAL, NO. 10	3
*34	1109466	MOTOR AND LEAD ASSEMBLY <i>Does Not Ship</i>	1
35	1911115	SCREW, M.S.P.H.C.R., SEMS, 6-32 x 5/16"	4
36	1109352	BRACKET, REAR COVER	2
37	1104295	INSULATOR	1
38	1911105	SCREW, M.S.P.H.C.R., SEMS, 8-32 x 1/4"	3
39	1911118	SCREW, M.S.P.H.C.R., SEMS, 8-32 x 5/8"	1
40	1102230	BRACKET, ROLL CARRIER ROD	2
41	1929703	RIVET, OVAL HEAD, SEMI-TUBULAR, 1/8	4
42	1102288	SPRING, SHAFT	2
43	1122048	PLATE, RIGHT HAND AND LEFT HAND SIDE	2
44	1929212	PIN, ROLL	4
45	1122003	SPINDLE, BRAKE	2
46	1102233	WELDED BRAKE SUBASSEMBLY	2
47	1102181	DISC, BRAKE FRICTION	4
48	1102187	DISC, BRAKE	2
49	1122009	FILM TENSION ADJUSTMENT DISC ASSEMBLY	2
50	1963127	TAPE	AR
51	1911115	SCREW, M.S.P.H.C.R., SEMS, 6-32 x 5/16"	1
*52	1105193	THERMOSTAT ASSEMBLY	2
53	1926801	NUT, HEX, KEPS, 6-32	2
54	1105195	CONNECTOR, TERMINAL	2
55	1926707	NUT, HEX, 6-32	2
56	1902815	SCREW, M.S.P.H.C.R., 6-32 x 1/2"	2
*57	1105181	RESISTOR	1