

ibico  **Patriot 25E**

© 2002 IBICO. ALL RIGHTS RESERVED.

Do not duplicate without written permission.

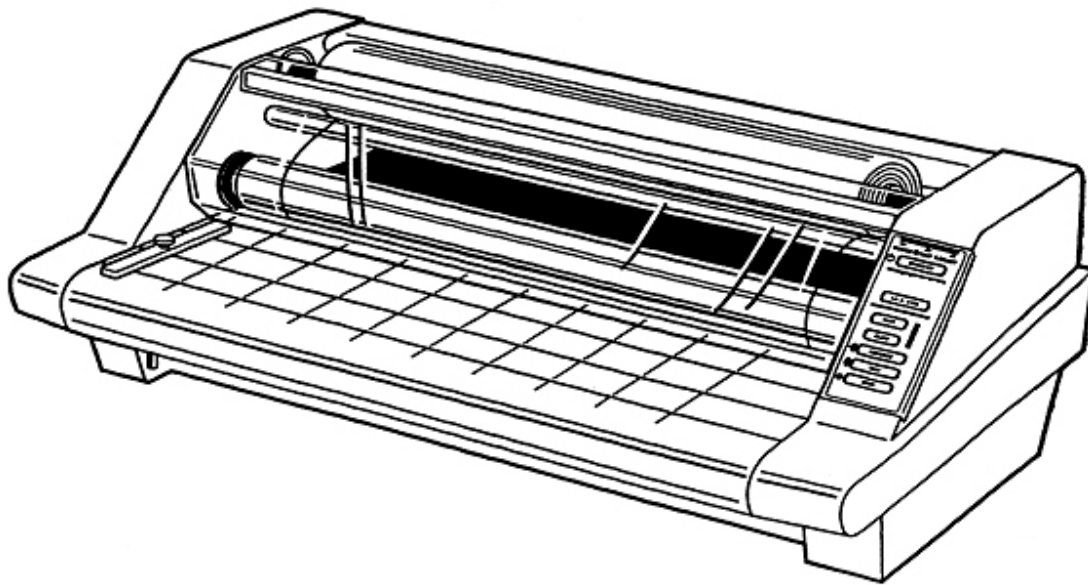

Part number : 930 - 076B



The information in this publication is provided for reference and is believed to be accurate and complete. Ibico is not liable for errors in this publication or for incidental or consequential damage in connection with the furnishing or use of the information in this publication, including, but not limited to, any implied warranty of fitness or merchantability for any particular use.

Ibico reserves the right to make changes to this publication and to the products described in it without notice. All specifications and information concerning products are subject to change without notice.

Reference in this publication to information or products protected by copyright or patent does not convey any license under the rights of Ibico or others. Ibico assumes no liability arising from infringements of patents or any other rights of third parties.

This publication is copyrighted © 2002 by Ibico. All rights reserved. The information contained in this publication is proprietary and may not be reproduced, stored, transmitted, or transferred, in whole or in part, in any form without the prior and express written permission of Ibico. Ibico a company of GBC.

Table of contents

1.0 Safety	
1.1 Explanation of symbols	1-1
1.2 General Rules of safety	1-1
1.3 Labels	1-2
Figure 1.3.1 Safety label placement	1-3
2.0 Warranty	
2.1 Limited warranty	2-1
2.2 Exclusions to the warranty	2-1
3.0 Specifications	
3.1 Film capacity	3-1
3.2 Operating speed	3-1
3.3 Weight	3-1
3.4 Electrical requirements	3-1
3.5 Dimensions	3-1
Figure 3.5.1 Patriot 25E	3-2
4.0 Installation	
4.1 Setting up the laminator	4-1
4.2 Know your laminator	4-2
5.0 Operations	
5.1 Components on the laminator	5-1
5.2 Control panel	5-3
Figure 5.2.1 Control panel	5-3
5.3 Feed table	5-4
5.4 Supply shaft	5-4
5.5 Film alignment	5-4
5.6 Adjusting film tension	5-5
6.0 Applications	
6.1 Film loading and threading	6-1
6.2 Starting an application	6-2
6.3 Speed guide	6-4
Figure 6.3.1 Speed guide	6-4
6.4 Helpful hints	6-5
6.5 Important points to remember	6-5
7.0 Maintenance and troubleshooting	
7.1 Cabinets, cover and stand	7-1
7.2 Clean the rollers	7-1
7.3 Troubleshooting	7-2
Figure 7.3.1 Troubleshooting guide	7-3

8.0 Recommended spares

8.1 Spare parts list	8-1
----------------------	-----

9.0 Illustrated parts

9.1 Parts list	9-1
9.2 Illustrations	9-4
P25E-001 Slitter assembly	9-4
P25E-002 Covers and table assembly	9-5
P25E-003 Control panel assembly	9-6
P25E-004 Cover and film shaft assembly	9-7
P25E-005 Frame assembly	9-8
P25E-006 Control side assembly	9-9
P25E-007 Rollers and heater assembly	9-10
P25E-008 Drive side assembly	9-11
P25E-009 Latch assembly	9-12
P25E-010 Electrical Schematic	9-13

1.0 Safety



CAUTION: Do not attempt to operate your Patriot 25E Laminator until you completely read and understand this Operations Manual.

Your safety, as well as the safety of others, is important to Ibico. This section contains important safety information which must be adhered to while operating, cleaning and performing basic maintenance in and around the machine.

1.1 Explanation of symbols



INFORMATION: *[This symbol is used prior to, during and/ or after a step. Following this symbol is important information pertaining to current subject.]*



CAUTION: *[This symbol is used prior to a step. The information following this symbol is to inform you of how to avoid harm to you, others around you or to the equipment.]*



WARNING: *[This symbol is used prior to a step. The information following this symbol is to inform you of how to avoid a dangerous situation.]*



ELECTRICAL HAZARD: *[This symbol is used prior to a step. The information following this symbol is to prevent an electrical shock condition that may be caused by an operators action or machine function.]*

1.2 General rules of safety



ELECTRICAL HAZARD: Do not operate the laminator if power cord is damaged or frayed. You can be severely shocked, electrocuted or cause a fire.



WARNING: Do not operate this laminator if you are not physically, psychologically or emotionally fit. Do not operate this machine until you have been trained and read this manual in it's entirety.



WARNING: Do not wear ties, loose fitting clothes or dangling jewelry while operating or servicing the laminator. These items can get caught in the nip and choke you or you can be crushed or burned.



WARNING: Never tamper with the safety devices to increase the laminator's production capacity. In the event a safety device should fail, never attempt to bypass it for operation. Consult a service representative immediately.



WARNING: Never use this machine for any other purpose than its intended design and function.



WARNING: Do not make any modifications to this laminator. Unauthorized changes will void your warranty and may cause extensive repairs or create poor output quality.



CAUTION: Only use acceptable materials through this laminator. Unacceptable materials may cause damage to the rollers or cause poor output quality.



CAUTION: Exercise extreme caution when working around or replacing the film cutter blade. This blade is sharp and cut you.



INFORMATION: Always observe all warning labels placed at various points on the laminator. If you do not completely understand a label, contact your local service representative for further explanation.



INFORMATION: Any concerns for safety or operation should be brought to the attention of your local service representative immediately.

1.3 Labels

Refer to Figure 1.3.1 Label locations

Safety warning labels are placed at various locations on the laminator. Do not remove any of these labels. They are place for your safety as well as the safety of those working around you.

Below are illustrations of the safety labels and a description of thier meanings.

Hot rollers

– The safety label below means that you could be burned and your fingers and hands could be trapped and crushed in the heat rollers. Jewelry and long hair could be caught in the rollers and you could be pulled into them.

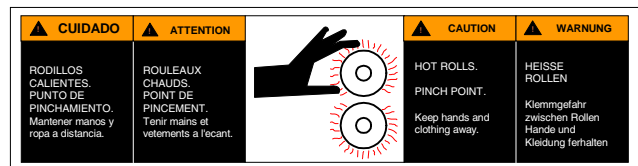

One label is placed on each side from the front operating position just in front of the heat rollers nip.

Electrical hazard

– The safety label below means that you could be seriously hurt or killed if you open the product and expose yourself to hazardous voltage.

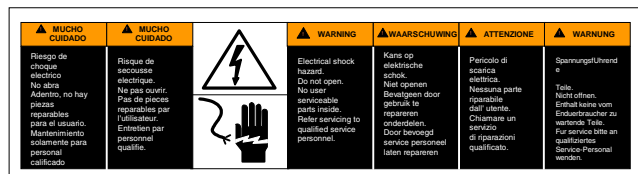

This label is located on the rear panel in the center of the laminator just below the rear slitler.

Sharp knife

– The safety label below means that you could cut yourself if you are not careful.



This label is located on the rear panel in the center of the laminator just above the Electrical hazard safety label and below the rear slitter.

Pinch point

– The safety label below means use extreme caution when placing your hands in the proximity of the pull rollers nip. You should never place your fingers or other items in this area while the machine is running.



This label is located between the pull rollers and the rear slitter guide center of the rollers.

Figure 1.3.1 Safety label placement

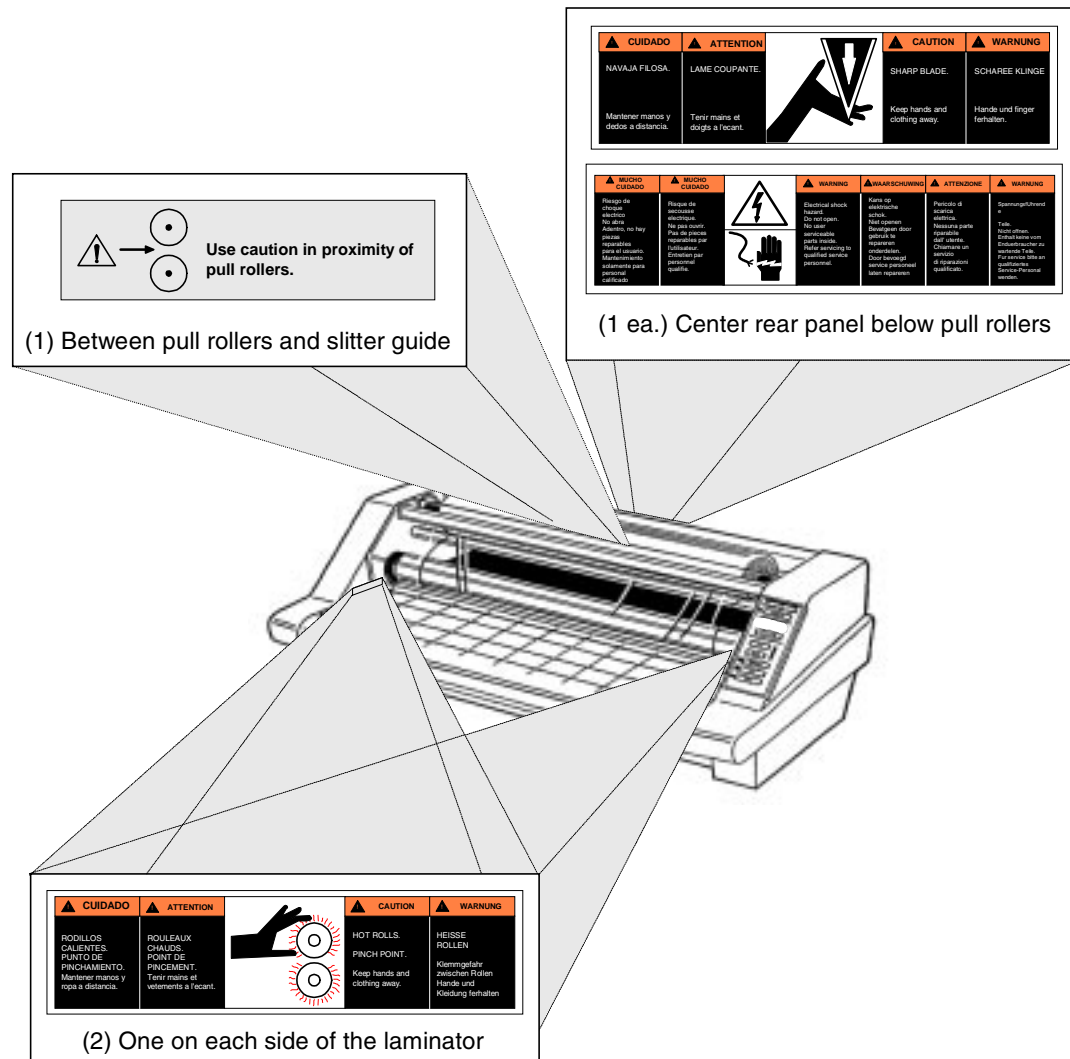

This page intentionally left blank.

2.0 Warranty

IBICO warrants the equipment to be free from defects in material and workmanship for a period of **90 days for parts and labor** from the date of installation. This warranty is the only warranty made by IBICO and cannot be modified or amended.

IBICO's sole and exclusive liability and the customer's sole and exclusive remedy under this warranty shall be, at IBICO's option, to repair or replace any such defective part or product. These remedies are only available if IBICO's examination of the product discloses to IBICO's satisfaction that such defects actually exist and were not caused by misuse, neglect, attempt to repair, unauthorized alteration or modification, incorrect line voltage, fire, accident, flood or other hazard.

2.1 Limited Warranty

This warranty specifically does not cover damage to the laminating rollers caused by knives, razor blades, other sharp objects, failure caused by adhesives or improper use of the machine. Warranty repair or replacement does not extend the warranty beyond the initial 90 day period from the date of installation.



CAUTION: Unauthorized customer alterations will void this warranty.

THE WARRANTY MADE HEREIN IS IN LIEU OF ALL OTHER WARRANTIES, EXPRESSED OR IMPLIED, INCLUDING ANY WARRANTY OR MERCHANTABILITY OR FITNESS FOR A PARTICULAR PURPOSE. GBC FILMS GROUP WILL NOT BE LIABLE FOR PROPERTY

DAMAGE OR PERSONAL INJURY (UNLESS PRIMARILY CAUSED BY ITS NEGLIGENCE), LOSS OF PROFIT OR OTHER INCIDENTAL OR CONSEQUENTIAL DAMAGES ARISING OUT OF THE USE OR INABILITY TO USE THE EQUIPMENT.

2.2 Exclusions to the Warranty

This warranty specifically does not cover;

- 1.** Damage to the laminating rolls caused by knives, razor blades, other sharp objects or failure caused by adhesives.
- 2.** Damage to the machine caused by lifting, tilting and/ or any attempt to position the machine other than rolling on the installed castors on even surfaces.
- 3.** Improper use of the machine.
- 4.** Damage due from unqualified person(s) servicing the machine.

Qualified;

- Any engineer that has experience with electrical and mechanical design of lamination equipment. The engineer should be fully aware of all aspects of safety with regards to lamination equipment.

- Any commissioning or service engineer must be of competent nature, trained and qualified to IBICO standards to fulfill that job. This person will have completed and passed the full service training course from IBICO.

- Any IBICO Technician and/ or IBICO Specialist that has been through the IBICO service training course.

This page intentionally left blank.

3.0 Specifications

Voltage-	120V ~ 60Hz (230V ~ 50Hz)
Current-	13.4 A (7.8A)
Power-	1610W (1800W)

This section provides specific information regarding the laminator. Any specification not provided must be requested from Ibico.

3.1 Film capacity

Width - 27 inches (68 cm)
Gauge - 1.5, & 3 mil
Core - 1 in & 2-1/4 in. (2.54 & 5.72 cm)

3.2 Operating speed

1.5 - 10 fpm (45.7 cm - 3 m)

3.3 Weight

Unpacked- 85 pounds (39 kg)
packed- 90 pounds (41 kg)

3.4 Electrical requirements



INFORMATION: *Refer to the serial plate located on the rear of the laminator for specific electrical ratings applicable to the unit.*

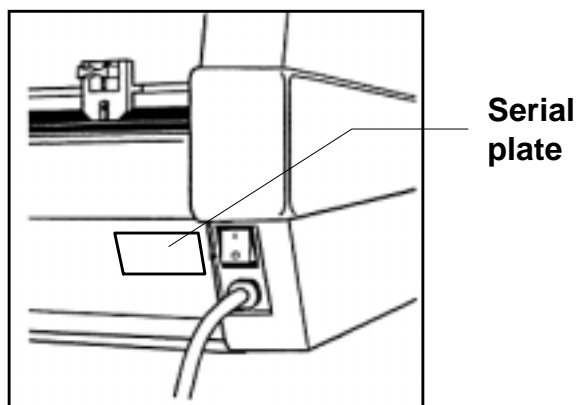

3.5 Dimensions (L x W x H)

Refer to **Figure 3.5.1 Patriot 25E** for an illustration.

21 x 32.5 x 12 inches
(53 x 83 x 31 cm)

Figure 3.5.1 Patriot 25E

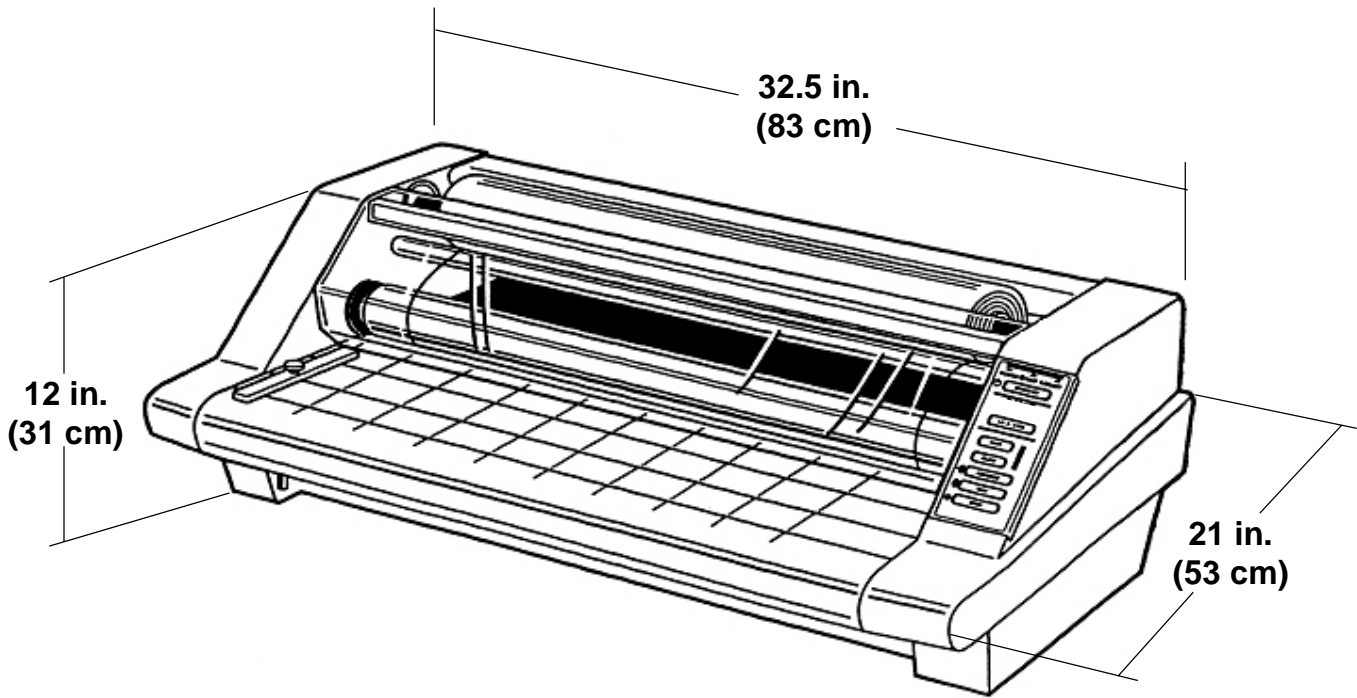

4.0 Installation

This section will guide you through the installation process of the laminator.



INFORMATION: Shipping damage should be brought to the immediate attention of the delivering carrier.

4.1 Setting up the laminator

1. Place the Patriot 25E on a stable flat surface capable of supporting at least 95 lbs. (45kgs).

The surface should be at least 30 inches high to assure comfortable positioning during operation.



CAUTION: Too high or too low of an operating position can lead to serious bodily injury.

All four rubber support feet should be positioned completely on the supporting surface.



CAUTION: The laminator is a heavy piece of equipment and may cause injury if it falls and/ or require extensive repair work.

The supporting surface may also be large enough to hold the material being laminating.

2. The laminator should be positioned to allow exiting film to drop freely to the floor.



CAUTION: Accumulation of laminate immediately behind the laminator as it exits the equipment may cause the film to wrap around the pull rollers, resulting in a “jammed” condition.

3. Avoid locating the laminator near sources of heat or cold. Avoid positioning the laminator in the direct path of forced heated or cooling air.



INFORMATION: This affects the performance of the heating system and could result in poor output quality.

4. Connect the attachment plug provided with the laminator to a suitably grounded outlet only.

Refer to Section 3.4 Electrical requirements



CAUTION: Avoid connecting other equipment to the same branch circuit to which the laminator is connected. This may result in sporadic tripping of circuit breaker or blowing fuses.

4.2 Know your laminator

This section will assist you in understanding what and where items are when referred to in this manual.

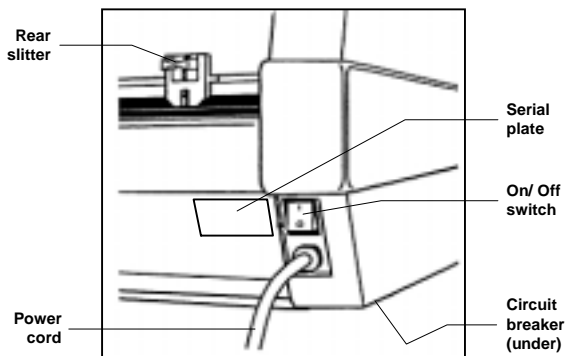
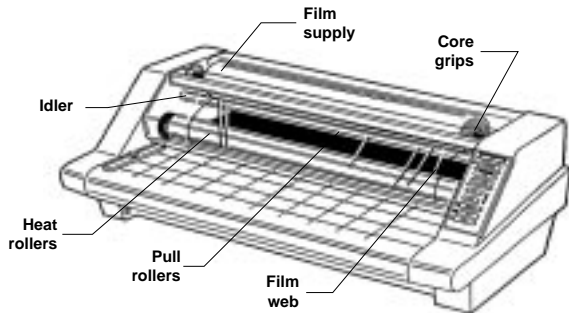
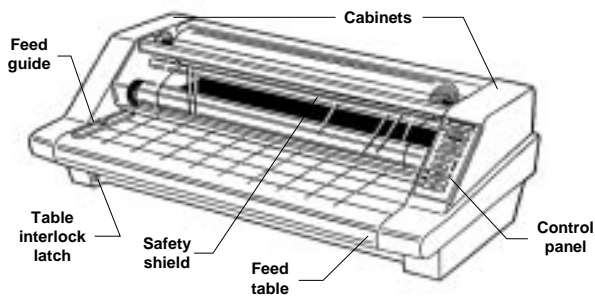
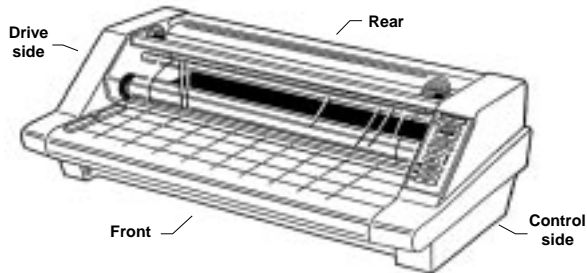

5.0 Operation

This section covers the components of the laminator, the control panel, the feed table, supply shaft, film alignment, film loading and threading, film tension, starting an application, speed guide, helpful hints and important points to remember.

5.1 Components on the laminator

Refer to Section 4.2 Know your laminator

(1) POWER ON/ OFF: Located at the back of the left side cabinet. When set to the “**I**” position, applies power to the laminator. When set to the “**O**” position, removes power to the laminator.

(2) SAFETY SHIELD: Prevents entanglement, entrapment and inadvertent contact with the heat rollers.



INFORMATION: The laminator will operate only when the safety shield is located in the fully down position. Power to the motor is removed when the safety shield is in the raised position.

(3) FEED TABLE: The feed table is used to position items for lamination.



INFORMATION: The laminator will operate only when the feed table is installed and the table interlock latch is properly engaged.

(4) TABLE INTERLOCK LATCH: Used to lock the feed table into position and activate an interlock switch. This interlock latch is located on the underside of the feed table on the drive side from the front operating position. The table can not be removed without retracting the latch

(5) FEED GUIDE: The feed guide permits alignment of the item(s) to be laminated and is used to keep longer items straight.

The feed guide may also be used to feed smaller items side by side by positioning the guide towards the center of the feed table and placing the smaller items against each side of the feed guide as they are being introduced to the nip point of the heat rollers.

To position the adjustable guide, loosen the knob on the top of the guide, slide it to the desired position and tighten the knob to secure in place.

(6) HEAT ROLLERS: Silicone rubber coated steel tubes. Used to heat the laminating film and compress the film to the items being laminated. Heat is provided by an internal infrared element. The heat rollers are motor driven for ease of loading new film.



WARNING: Avoid contact with the heat rollers. Direct contact with the heat rollers can burn you.

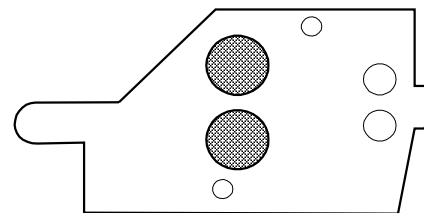

(7) IDLER BAR: The idler bars, located near each supply roll, are used to direct the film to the heat rollers. The bottom idler is movable to ease film loading.

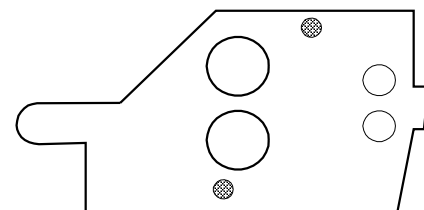

(8) PULL ROLLERS: The pull rollers, located at the back of the laminator, are motor driven. They simultaneously pull the film and improve the quality of the laminated item.

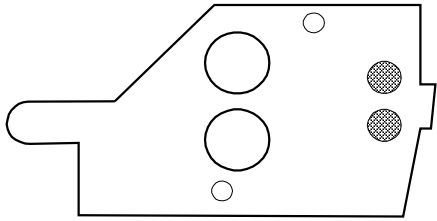

(9) REAR SLITTER: Used to cut the film web where it exits the rear of the laminator. To make a cut, press and hold down the blade lever and slide across the rear of the laminator.



WARNING: Never reach over the laminator to operate the film cutter. Reaching over can make you unstable and may cause serious bodily injury.



CAUTION: Exercise extreme caution when working around or replacing the film cutter blade. This blade is sharp and can cut you.

(10) CIRCUIT BREAKER: Electrical safety device, located under the drive side cabinet cover, can be reset by the operator if tripped.



CAUTION: If the circuit breaker trips a second time after being reset, contact your service representative for assistance.

(11) CORE ADAPTERS: The film shaft holds the supply roll while the core adapters hold the rolls of film on the shaft.

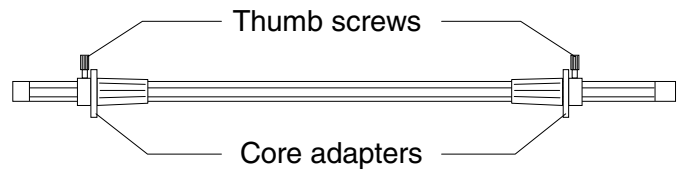

(12) FILM WEB: Laminating film loaded into the machine

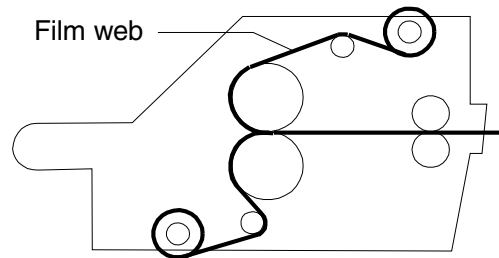

(13) NIP POINT: The point at which the top and bottom rollers come into contact. The nip point of the heat rollers is the place at which the items for lamination are introduced into the laminator.



CAUTION: Only feed acceptable materials through the nip of the rollers. Unacceptable materials may cause damage to the rollers.

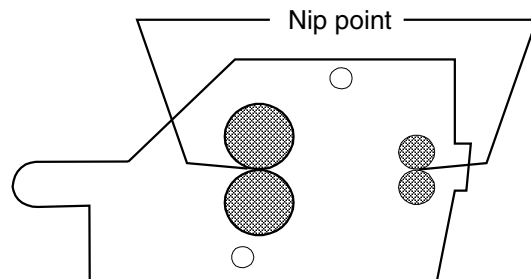

5.2 Control panel

Figure 5.2.1 Control panel

Refer to Figure 5.2.1

(1) POWER: This light illuminates when power to the laminator is “ON”. If this lamp is not lit, no power to the laminator is being supplied.

(2) HEAT: Illuminates when the laminator is first turned on and when the laminator calls for more heat.

(3) READY: Indicates when the laminator has sufficient heat for the selected film gauge.

(4) STANDBY: Illuminates indicating the laminator is in “STANDBY” mode. In standby mode, the temperature is reduced. Press this button to revert to operating mode. The temperature will restore itself to the predetermined film gauge setting.

(5) 1.5 & 3 MIL: This button must be pressed to set temperature and speed settings required to for these thicker gauge films.

(6) FAST: When pressed, increases the speed of the laminator by overriding the preset condition.

(7) SLOW: When pressed, decreases the speed of the laminator by overriding the preset condition.

(8) REVERSE: When pressed, reverses the roller direction. Use this button to clear film jams and wrap-ups.

(9) RUN: When pressed, activates rollers for normal operation.

(10) STOP: When pressed, stops the movement of the rollers.

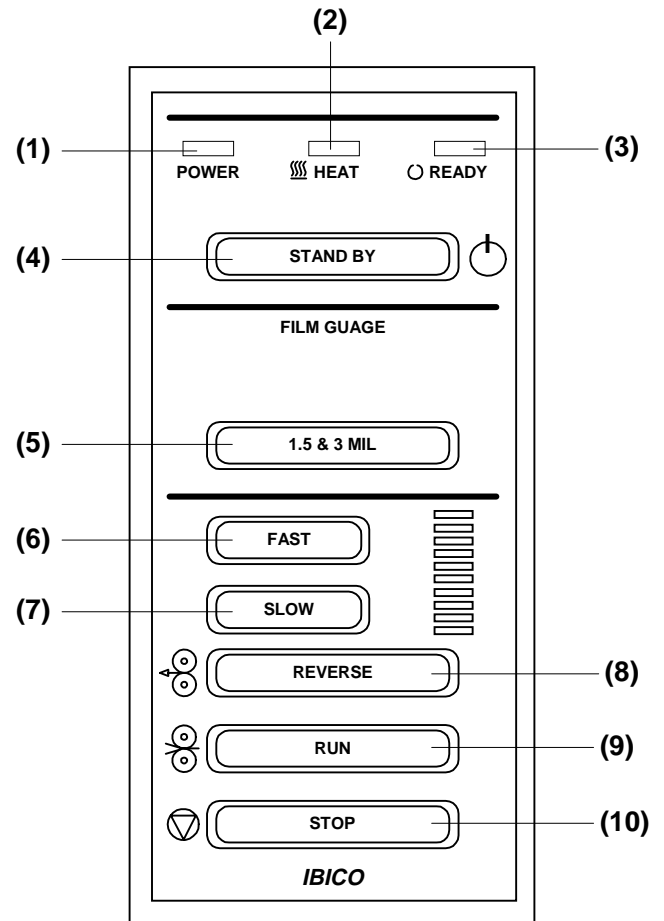

5.3 Feed table

To remove

1. Lift the safety shield to its full upright position.
2. Slide the feed table interlock latch to the right.
3. Lift the rear of the table (the rounded side) upwards and then away from the laminator.

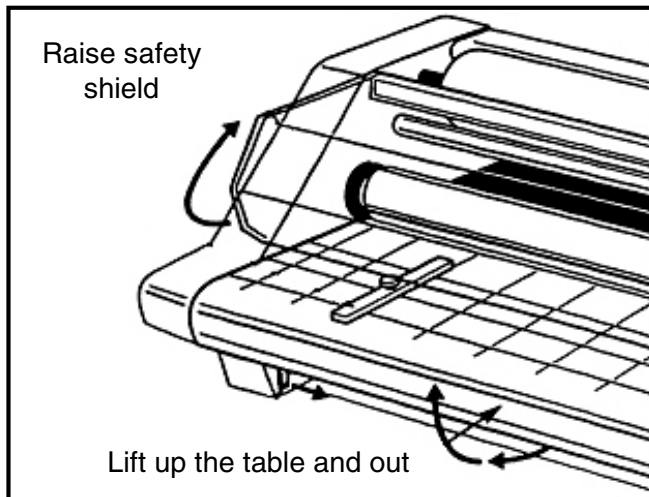

To replace

1. Set the front of the feed table (the side that is not rounded) into the table brackets first.
2. Lower the rear of the feed table onto the table support bar.
3. Slide the table interlock latch to the left.
4. Lower the safety shield to its fully closed position.

5.4 Supply shaft

To remove

1. Slide the upper shaft to the right from the front operating position.
2. While pushing in on the supply shaft to the right, remove the left side of the shaft from the brake assembly.
3. Raise the safety shield and remove the table and repeat the steps above for the lower supply shaft.

To replace

1. Align the rounded end of the supply shaft into the supply shaft hole located on the right side of the laminator from the front operating position.
2. Push the supply shaft in while aligning the hex end of the supply shaft with the brake assembly.

5.5 Film alignment

The film supply shafts come with pre alignment holes on the right side for 9 in. (21 cm), 12 in. (31 cm), 18 in. (46 cm), 25 in. (64 cm) and 27 in. (69 cm) film widths. Loosen the locking screw on the right side core adapter and move the to the corresponding hole to match the width of your roll of film. Tighten the locking screw in the pre drilled hole.

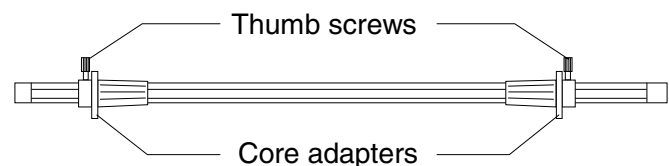

5.6 Adjusting film tension

Proper film tension, known as brake tension, is the minimum amount of tension required to eliminate wrinkles in the finished item.

The film tension is set at the factory. Periodic adjustments should not be necessary unless other than 1.0, 1.5 or 3 mil film is being used or the lamination is curling up or down.

The film should be taut. A properly adjusted roll of film should not require excessive force to turn by hand. Film tension should be enough to introduce a minor amount of drag as the film unrolls.

Insufficient tension causes wrinkles while too much tension between the top and bottom rolls creates curl. Too much upper tension causes upward curl while too much bottom tension causes a downward curl.

Follow the procedure described below to adjust film tension.

1. To adjust the bottom brake, push and hold the brake lever located on the left side frame by the roll of film.

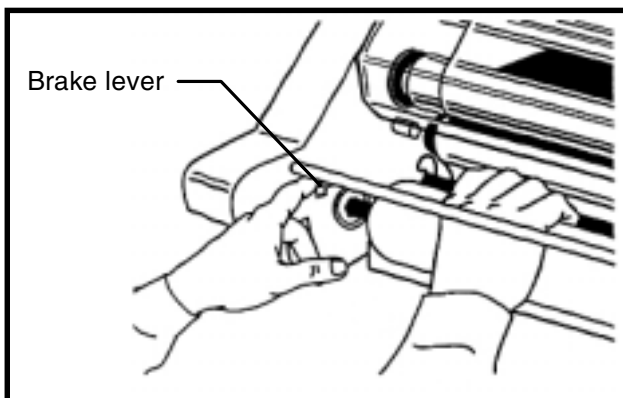

2. Rotate the roll of film until the lever engages the internal mechanism.

3. Rotate the roll of film clockwise to increase tension and counter clockwise to decrease tension.

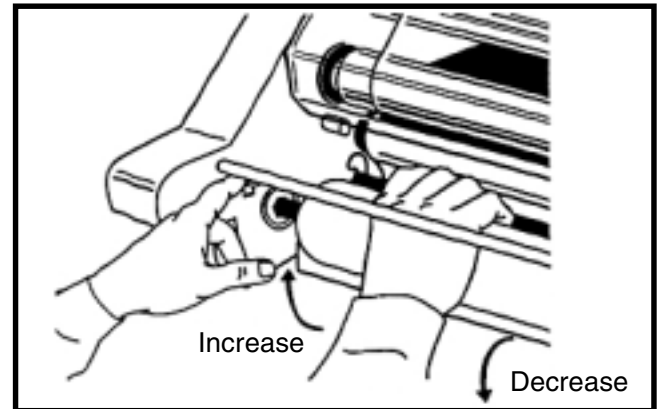

4. Release the brake lever and check the tension by rotating the roll of film. Resistance should be slight, not forced.

5. Repeat steps above to adjust the top brake.

6. Run some test samples to verify proper brake tension. Adjust if necessary.

This page intentionally left blank.

6.0 Applications

The Patriot 25E will accommodate rolls of film on a 1 in. (2.54 cm) and 2-1/4 in (5.72 cm) cores. This section covers how to load and thread film and start an application. A speed guide, helpful hints and important points to remember are provided.

6.1 Film loading and threading



CAUTION: The laminator should be cool to the touch before proceeding performing this procedure.



CAUTION: The top and bottom rolls of film must be of the same width and be present simultaneously. Do not allow one roll of film to run out before the opposite roll of laminating film.

1. Remove the feed table.
2. Remove the unwind shafts from the laminator. Remove the core adapters from the unwind shafts.
3. Move the lower idler out of the locked position.

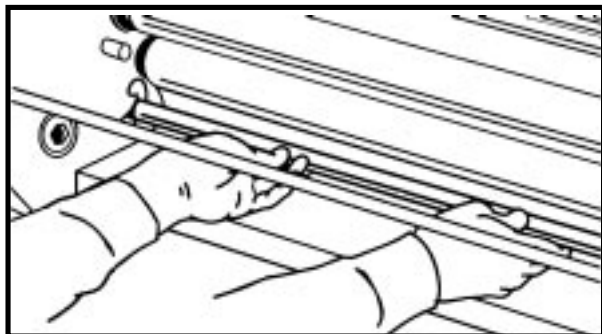

4. Slide the rolls of laminating film onto the unwind shafts so the adhesive is facing away from the heat rollers when replaced into the laminator.



CAUTION: The dull side of the film contains the adhesive. Use extreme caution when loading delustered (matte) film as both sides appear dull.

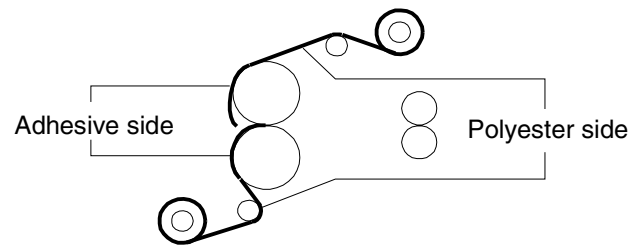

5. Align the film and secure the rolls of laminating film in place by tightening the thumb screws located on the core adapters.



INFORMATION: If using standard rolls of film, use the pre-aligned holes on the supply shaft.

6. Pull the lower roll of laminating film around the lower idler and back towards the front of the laminator. Pull enough film to allow it to drape over the roll.

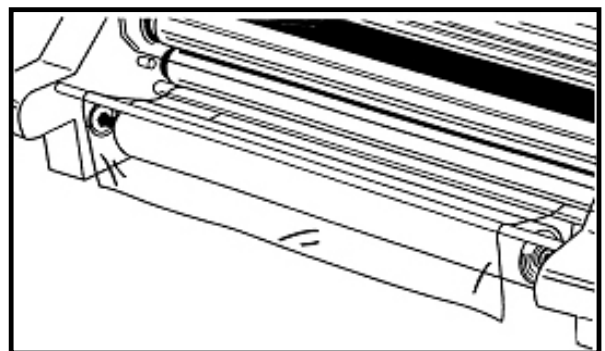

7. Move the lower idler into the locked position.

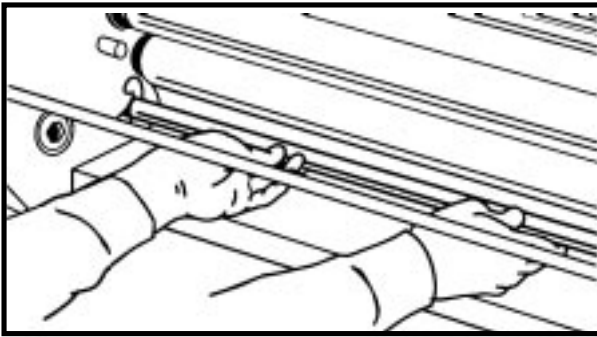

8. Pull the upper laminating film down over the upper idler and drape over the heat rollers.

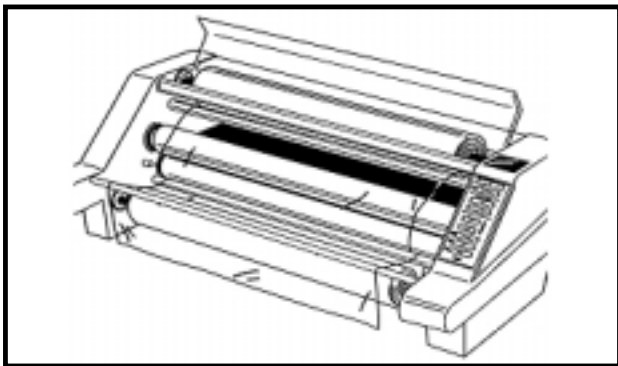

9. Slide the feed table under the draped film from the lower supply roll and replace the feed table ensuring the film stays on top of the feed table. Lower the safety shield into the fully closed position.

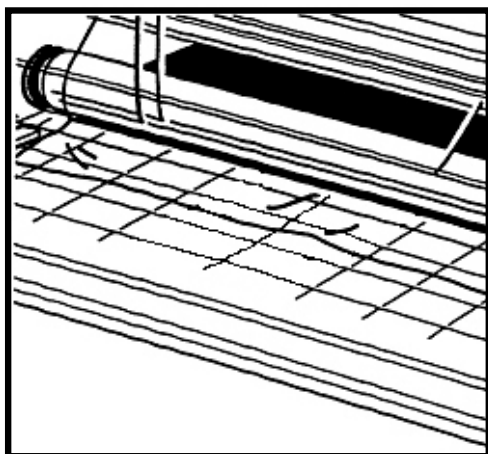

10. Slide the threading card (a piece of heavy stock paper, card board or similar product) between the feed table and the film resting on the feed table. Push the threading card into the nip of the heat rollers.

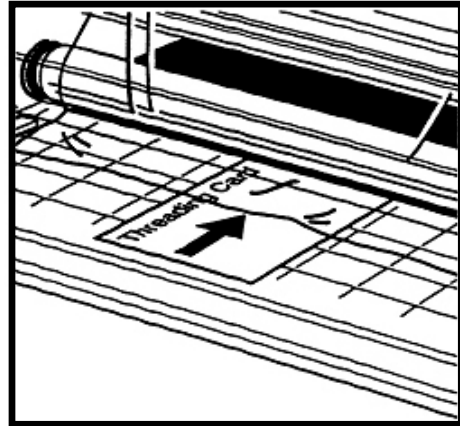

11. Turn power to **ON** and press **RUN**.

12. Once the threading card has completely exited the rear of the laminator, press **STOP**.

13. Trim the threading card off using the rear slitter.

6.2 Starting an application



CAUTION: Ensure the safety shield is in the fully closed position and the feed table is properly installed with the table interlock latch in position.

1. Turn the laminator on by pushing ON/OFF to the “I” position.
2. The laminator will automatically default to the 1.5 & 3 MIL setting.
3. The laminator will set the speed and temperature for the respective film and 20 lb. bond paper (copier paper).



INFORMATION: Decrease speed by pressing **SLOW** if laminating heavier stock. Increase speed by pressing **FAST** if you are laminating lighter stock.

Refer to Section 4.6 Speed guide and helpful hints



INFORMATION: **HEAT** may illuminate if increasing speed to high. If the adhesive is not activating (becomes tacky), slow the speed down to achieve quality lamination.

4. Adjust the feed guide while you wait for **READY** to illuminate. Do not run any material through the laminator until **READY** has illuminated.

5. Position the item(s) on the feed table to be laminated.
6. Ensure the rear slitter is completely to one side on the laminator.



CAUTION: Anything obstructing the path of the film exiting the rear of the laminator may cause a film jam (wrap-up).

7. Press **RUN**. The rollers will begin to turn.

8. Wait for the heat line (dwell line) to disappear, then push the items into the nip point of the heat rollers. Additional items can be laminated without stopping and starting the laminator.

9. Once the last item laminated has completely exited the rear of the laminator, press the **STOP**.

10. Use the rear slitter to trim the laminated items from the web.



WARNING: Never reach over the laminator to operate the film cutter. Reaching over can make you unstable and may cause serious bodily injury.

11. Turn the laminator off by pushing the On/Off switch to the “O” position.



INFORMATION: You do not need to un-web the laminator after turning power off except to clean the rollers. Refer to Section 7.2 Clean the rollers.

6.3 Speed guide

The following chart provides general guidelines for proper speed settings to use on certain materials and laminating film combinations.



INFORMATION: Different settings may become necessary as the warm up time, lamination time and materials change.

Figure 6.3.1 Speed guide

Material	Film thickness	
	1.5 mil (0.0015")	3.0 mil (0.0030")
Newspaper 20 lb. copier paper Magazine stock Tissue stock	5	3
Construction paper Posters	4	2
Index cards File folders Poster boards	3	1

6.4 Helpful hints

Good consistent lamination is a result of combining proper heat, speed, tension and dwell time. Dwell time is the amount of time the material to be laminated is compressed between the heat rollers and is controlled by the speed of the laminator.

As a general rule, thicker items and films as well as items with dark or full ink coverage, need to run at a slower speeds because they extract more heat from the rollers at a quicker rate.

Thinner items, such as standard copier paper (20lb.bond) and tissue stock, extract less heat from the rollers and can be run at faster speeds.

Operation of the laminator for more than thirty minutes at a time may necessitate a lower speed setting. It is recommended that during periods of long runs the items being laminated are alternated between thick and thin.

If you are ever unsure that your laminator is set at proper speed, run a test piece (scrap) of the same or similar material through the laminator. Rotating the heat rollers prior to laminating distributes the heat evenly throughout the heat rollers.

Always change the top and bottom supply rolls at the same time. This will prevent adhesive from getting on the rollers. Adhesive will deposit on the rollers if:

- Only one roll of film is used.
- Different widths of rolls are loaded together.
- Either roll is loaded adhesive side against a heat roller.
- One or both rolls of film are allowed to run completely off the cores.

Always use the minimum brake tension necessary to achieve the desired results. Using the maximum amount will yield unwanted results after close inspection. You may see stretching, waves in the laminate, distortion of the image and/ or curling.

6.5 Important points to remember



WARNING: Do not press RUN until READY has illuminated.



WARNING: To cut film or web, only use the rear slitter or an enclosed blade around the laminator.



WARNING: Do not force items into the laminator. An item that is not easily drawn into the laminator is probably too thick to laminate.



WARNING: Do not attempt to laminate abrasive or metal objects such as staples, paper clips and glitter as they may damage the heat rollers.



WARNING: Do not attempt to laminate adhesives marked “FLAMMABLE”.



CAUTION: Avoid direct contact with the heat rollers when changing the supply rolls after the laminator has been running.



CAUTION: Do not stop the laminator before an item has completely exited the pull rollers. Even a momentary stop will cause a dwell line (heat line) on the laminated item.



INFORMATION: Wrinkles may result if an attempt is made to reposition an item once it has entered the nip of the heat rollers.



INFORMATION: When feeding long items, skewing may occur if the item is not fed into the laminator straight. Use the feed guide to help prevent this from happening.



INFORMATION: When feeding two items into the laminator, do not mix thin and thick items together as this will create a poor edge seal.



INFORMATION: If the machine is not working, always check that the safety shield is properly closed, the feed table is properly installed and the circuit breaker has not tripped before placing a service call.

7.0 Maintenance & Troubleshooting

IBICO laminators require minimal maintenance. However, regular maintenance is essential to keep any piece of precision machinery at peak performance. A maintenance schedule and a section of procedures are included in this section.



WARNING: Do not wear ties, loose fitting clothes or dangling jewelry while operating or servicing the laminator. These items can get caught in the nip and choke you or you can be crushed or burned.



INFORMATION: Improper maintenance can result in poor output quality.

IBICO offers Cleaning kits (P/N 1711515) as well as Extended Maintenance Agreements.

The only maintenance required by the operator is to maintain clean and adhesive free nip rollers and overall cleanliness of the laminator itself.



ELECTRICAL HAZARD: Do not use liquid or aerosol cleaners on the laminator. Do not spill liquid of any kind on the laminator. You can be severely shocked, killed or cause a fire. Use only a damp cloth for cleaning unless other wise specified.

7.1 Cabinets, cover and stand



ELECTRICAL HAZARD: Remove power from the laminator before cleaning. You can be severely shocked, killed or cause a fire.

1. Use a damp (use water only to dampen the cloth) white terry cloth towel to wipe dust from the cabinets, cover and stand.

7.2 Clean the rollers



CAUTION: This procedure is performed while the laminator is HOT! Use extreme caution. Direct contact with the rollers can burn you!



CAUTION: Hardened adhesive deposits on the rollers can cause damage to the rollers. Rotate the rollers at the lowest speed setting on the control panel.



WARNING: Do not apply cleaning fluids or solvents to the rollers! Fluids and solvents will have a direct effect on the rubber coated rollers and will require replacement.



WARNING: Do not use metal scouring pads to clean the rollers! Scouring pads will damage the rollers and require replacement.



WARNING: Never clean the rollers with sharp or pointed objects.

1. Remove the film from the laminator.
2. Preheat the laminator until the **READY** indicator illuminates.
3. Rub the top and bottom heat rollers with a 3M™ Scotch-Brite™ pad.
4. Install the feed table and lower the safety shield.
5. Press **RUN** to rotate the heat rollers to a new area for cleaning. Press **STOP**. Continue this process until the complete surface of both rollers are clean.
6. Follow the procedure in Section 4.6 Film loading and threading to reload the laminator.

7.3 Troubleshooting

As an operator, you can perform some basic troubleshooting before contacting your local service representative.



WARNING: Never remove the cabinets in attempt to troubleshoot the laminator. You may cause damage to other components or injury to yourself.



ELECTRICAL HAZARD: Do not remove the cabinets. You will be exposed to dangerous voltage which can shock or paralyze you.



CAUTION: Only trained technicians should perform service related work on the laminator.

Refer to **Figure 7.3.1 Troubleshooting Guide** on page 7-3.

Figure 7.3.1 Troubleshooting guide

Symptom	Possible cause	Corrective action
• POWER lamp does not illuminate when ON/OFF is in the ON position.	Laminator not connected to the electrical supply.	Insert attachment plug into receptacle.
	Circuit breaker open.	Reset circuit breaker.
• Heat rollers do not turn.	Safety shield in upright position.	Lower safety shield.
	Feed tray interlock pin not in place.	Slide interlock lever all the way into the left side frame.
• Laminated items exhibit wrinkles.	Tension on top or bottom roll of film is too loose.	Adjust tension per section Film Tension Adjustment .
	Bottom film roll may be improperly loaded.	Makesure the bottom roll of film is around the idler bar.
• Adhesive deposited on the heat rollers.	Top and bottom film webs not aligned.	Align film webs per section Film Alignment .
	Laminate improperly loaded.	Adhesive (matte) side of laminate film may be against the heat rollers. Load film per procedure outlined in section Film Loading and Threading .
• Unsatisfactory adhesion of laminate.	Speed setting too fast for type of material being laminated.	Lower speed setting by pressing SLOW .
	Insufficient heat.	READY must be illuminated.
	Laminate improperly loaded.	Adhesive side of film must be facing away from the heat rollers. Bottom roll of film not threaded behind the idler bar.
	Heat rollers require cleaning.	Clean heat rollers per section To Clean The Rollers .
	Laminated item unsuitable for adhesion.	Item may be dirty or may have non-porous surface that is extremely difficult to laminate.

This page intentionally left blank.

8.0 Recommended spares

8.1 Spare parts list

Part #	Item Description	Quantity	Drawing ref.
613050221	Rear slitter blade	1	P25E-001
604022032	Table guide knob	2	P25E-002
706011113	Control panel board	1	P25E-003
705200201	Infrared sensor	1	P25E-005
610010211	120V Transformer	1	P25E-005
706011114	Main PCB	1	P25E-006
704090102	Power ON/ OFF switch	1	P25E-006
704091045	Circuit breaker	1	P25E-006
704090415	Table micro-switch	1	P25E-006
704090414	Safety micro-switch	2	P25E-006
607040561	Pull roller	2	P25E-007
706025028	Heater	2	P25E-007
704150107	Thermostat	1	P25E-007
607040556	Main roller	2	P25E-007
701080233	1/4 in. chain gear	1	P25E-007
6090202	DC motor	1	P25E-008
701070150	Roller chain	1	P25E-008

This page intentionally left blank.

9.0 Illustrated Parts

The parts list is in numeric order. The parts illustration are in assembly order. If a part you require does not exist in the parts list or in the parts illustration section, contact you local service representative for assistance.



WARNING: Illustrated parts drawings are to be used only for ordering parts. They should not be used to perform repair work yourself. Contact your local service representative for service.



INFORMATION: The numeric value in the (), represent quantity per machine, not per assembly.

9.1 Parts list

Part #	Item Description	QTY	Unit
601230453	Roller cover	1	EA
601230521	Infrared heater support	2	EA
601230702	Inner tension panel	2	EA
601230802	Film shaft support panel	2	EA
601230804	Idler housing	1	EA
601250121	Side plate (L)	1	EA
601250122	Side plate (R)	1	EA
601250123	Film tension lever	2	EA
601250124	Power panel	1	EA
601250125	Circuit breaker support	1	EA
601250126	Sensor bracket	1	EA
601310501	Infrared heater inner support (N)	2	EA
601310504	Idler gear support	1	EA
601310508	Micro-switch support bracket	1	EA
601310509	P/R tension lever (L)	1	EA
601310510	P/R tension lever (R)	1	EA
601310511	Front lever fixing panel	1	EA
601310512	Tension adjustment panel	2	EA
601310521	Infrared heater outer support (N)	2	EA
604022032	Paper guide knob	2	EA
604022106	Paper guide	1	EA
604022111	Side cover (L)	1	EA
604022112	Side cover (R)	1	EA
604036131	Film guide screen (UP)	1	EA
604036133	Front base plate	1	EA

Part #	Item Description	QTY	Unit
604036135	Rear cover (UP)	1	EA
604036136	Rear cover (LOW)	1	EA
604036137	Roller cover cap	1	EA
604036138	Front table	1	EA
604037011	H/R roller hook	2	EA
604037021	1 in. core grippers	4	EA
607040556	H/ roller	2	EA
607040561	P/ roller	2	EA
6090202	DC geared motor (DM010)	1	EA
610010211	Transformer GM6635A-12	1	EA
613030151	Tie bar (PL)	1	EA
613030161	Upper idler roller (PL)	1	EA
613030162	Lower idler roller (PL)	1	EA
613030211	Hex film shaft (PL)	2	EA
613030301	Film Shaft Bushing (PL)	2	EA
613030527	Core bushing bolt (PL)	4	EA
613030537	Film tension bolt (PL)	2	EA
613030538	P/R tension bolt (PL)	2	EA
613030539	P/R support pin (PL)	2	EA
613030540	Auxiliary gear support pin (PL)	3	EA
613030541	Feed table hook support pin (PL)	2	EA
613030612	Roller cover support pin (PL)	1	EA
613030613	Feed table safety lever (PL)	1	EA
613040131	Column bushing (PL)	4	EA
701020209	Drawn needle bearing	4	EA
701050234	Flange bushing	6	EA
701050240	Flange bushing	4	EA
701070150	Roller chain	1	EA
701080233	Steel 1/4 chain gear	1	EA
701080265	Steel 1/4 chain gear	1	EA
701080271	Steel 1/4 chain gear	1	EA
701090115	Roller spring	2	EA
701090142	Film pipe spring	2	EA
701090157	Pull spring	2	EA
701090158	Compressed coil spring	2	EA
701090160	Feed table coil spring	1	EA
701090606	Spring ring	2	EA
701090832	Spring ring	2	EA
701090844	Spring ring	1	EA
701091201	R pin	2	EA

Part #	Item Description	QTY	Unit
701104803	T/S truss head 2 class T3.0 TH	6	EA
701106603	Set screw hexagon socket	2	EA
701110101	Nut	2	EA
701110104	Nut	2	EA
703010111	Rubber foot	4	EA
703010211	Wire protection ring	2	EA
703010332	Holder	4	EA
703020243	Control panel	1	EA
703020581	PC control key	1	EA
703020582	PC control key	1	EA
703020583	PC control key	1	EA
703020584	PC control key	1	EA
703020585	PC control key	1	EA
703020586	PC control key	1	EA
703020587	PC control key	1	EA
703070101	Friction panel (Leather)	4	EA
704030316	Cord plug 125 V UL	1	EA
704090102	Power S/W rocker	1	EA
704090313	Rubber key S/W	1	EA
704090414	Table micro-switch	3	EA
704090415	Safety micro-switch	1	EA
704091045	Circuit breaker	1	EA
704140403	Cord stopper	1	EA
704150107	Bi-metal thermostat	1	EA
705200201	Infrared sensor	1	EA
706011113	PCB display	1	EA
706011114	PCB main	1	EA
706025028	Infrared heater	2	EA
706111121	Back trimmer assembly	1	EA
802034301	PATRIOT decal (FRONT)	1	EA
802105042	Control panel decal	1	EA
803040379	Speed guide line decal	1	EA

PROPRIETARY
 GBC PRO-TECH CLAIMS PROPRIETARY RIGHTS TO THE MATERIAL DISCLOSED ON THIS DRAWING. IT IS ISSUED IN CONFIDENCE FOR ENGINEERING INFORMATION ONLY AND SHALL NOT BE REPRODUCED, COPIED OR DISCLOSED IN WHOLE OR IN PART, OR USED FOR MANUFACTURE OR FOR ANY OTHER PURPOSE WITHOUT WRITTEN PERMISSION FROM GBC PRO-TECH

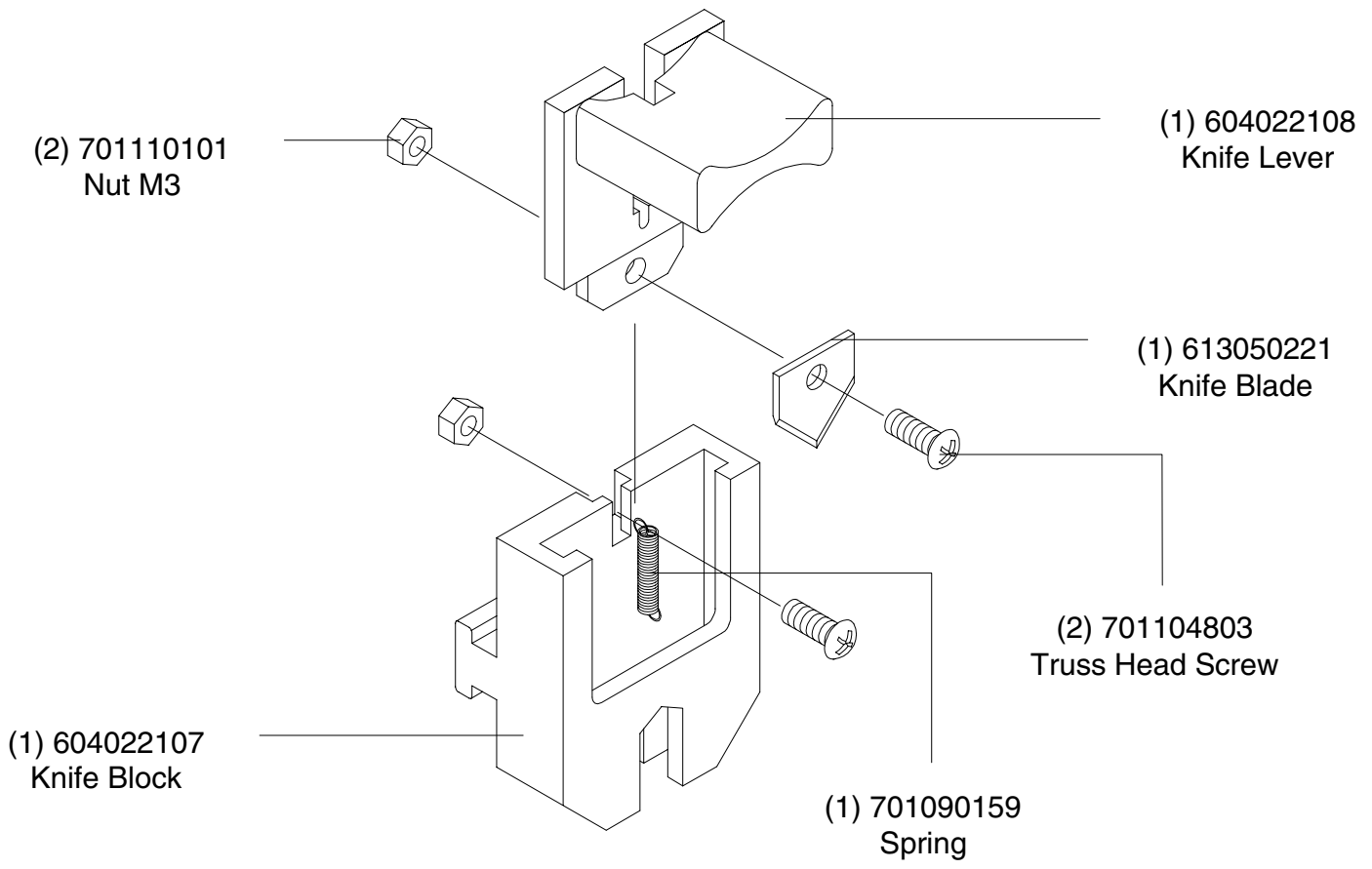

UNLESS OTHERWISE SPECIFIED TOLERANCE				GBC Films Group 4151 Anderson Road, DeForest, WI 53532			
DM, AS SHOWN	TOL.	FRESH TO BE	1/25	TITLE: Assembly, Slitter Patriot 25E			
XX	±.194			DATE:	DRAWN BY:	DWG SCALE:	DWG:
X	±.050			07/01/02	NSG	N/A	P25E-001
XX	±.010			ANGLES ±.10°			
XXX	±.000						
XXXX	±.005						

PROPRIETARY

GBC PRO-TECH CLAIMS PROPRIETARY RIGHTS TO THE MATERIAL DISCLOSED ON THIS DRAWING. IT IS ISSUED IN CONFIDENCE FOR ENGINEERING INFORMATION ONLY AND SHALL NOT BE REPRODUCED, COPIED OR DISCLOSED IN WHOLE OR IN PART, OR USED FOR MANUFACTURE OR FOR ANY OTHER PURPOSE WITHOUT WRITTEN PERMISSION FROM GBC PRO-TECH.

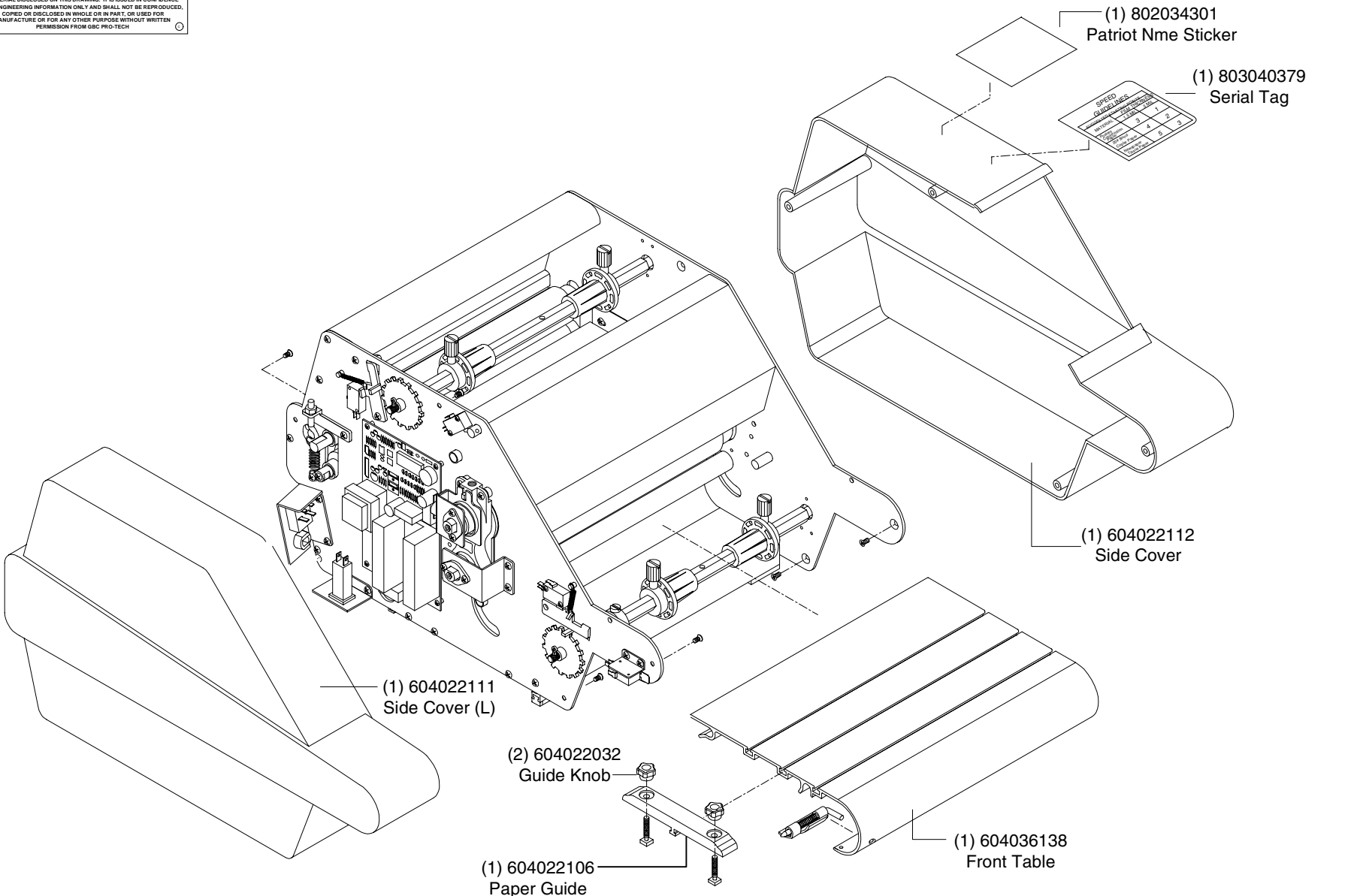

UNLESS OTHERWISE SPECIFIED TOLERANCE				GBC Films Group 4151 Anderson Road, DeForest, WI 53532			
DM. AS SHOWN	TOL.	FINISH TO BE	1/25	TITLE : Assembly, Covers and Table Patriot 25E			
XIX	±.184			DATE :	DRAWN BY :	DWG SCALE :	DWG :
X	±.050			07/01/02	NSG	N/A	P25E-002
XX	±.010						
XXX	±.005	ANGLES					
XXXX	±.005	±.0°					

PROPRIETARY
 GBC PRO-TECH CLAIMS PROPRIETARY RIGHTS TO THE MATERIAL DISCLOSED ON THIS DRAWING. IT IS ISSUED IN CONFIDENCE FOR ENGINEERING INFORMATION ONLY AND SHALL NOT BE REPRODUCED, COPIED OR DISCLOSED IN WHOLE OR IN PART, OR USED FOR MANUFACTURE OR FOR ANY OTHER PURPOSE WITHOUT WRITTEN PERMISSION FROM GBC PRO-TECH.

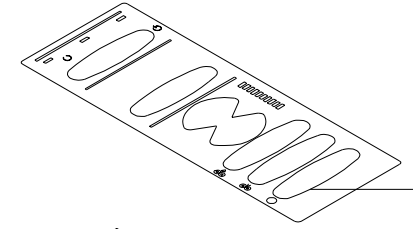

(1) 802105042
Decal Overlay

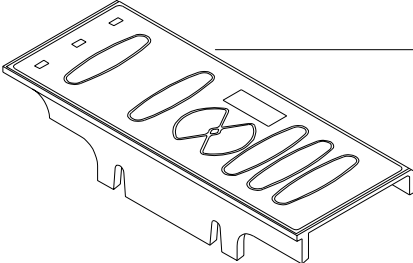

(1) 703020243
Pat25E Control Panel

- (1) 703020581 Stand by
- (1) 703020582 1.5 & 3 Mil.
- (1) 703020583 Fast
- (1) 703020584 Slow
- (1) 703020585 Reverse
- (1) 703020586 Run
- (1) 703020587 Stop

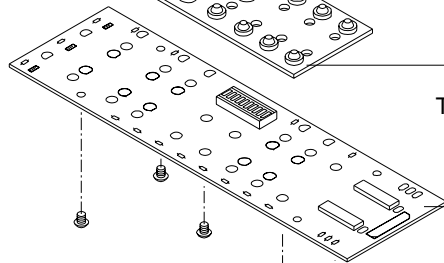
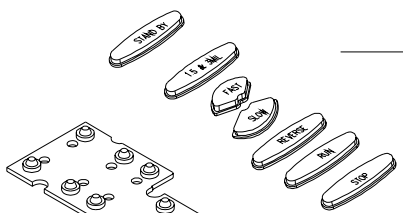

(1) 704090313
Touch Pad Control

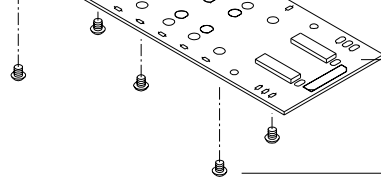

(1) 706011113
Control Board

(5) 701104803
Fasteners

UNLESS OTHERWISE SPECIFIED TOLERANCE			GBC Films Group 4151 Anderson Road, DeForest, WI 53532	
SIN. AS SHOWN	TOL.	FINISH TO BE	TITLE : Assembly, Control Panel Patriot 25E DATE : 07/01/02 DRAWN BY : NSG DWG SCALE : N/A DWG : P25E-003	
XX	±.184			
X	±.050			
XX	±.010			
XXX	±.005			
XXXX	±.002	ANGLES AS SHOWN		

PROPRIETARY
 GBC PRO-TECH CLAIMS PROPRIETARY RIGHTS TO THE MATERIAL DISCLOSED ON THIS DRAWING. IT IS ISSUED IN CONFIDENCE FOR ENGINEERING INFORMATION ONLY AND SHALL NOT BE REPRODUCED, COPIED OR DISCLOSED IN WHOLE OR IN PART, OR USED FOR MANUFACTURE OR FOR ANY OTHER PURPOSE WITHOUT WRITTEN PERMISSION FROM GBC PRO-TECH.

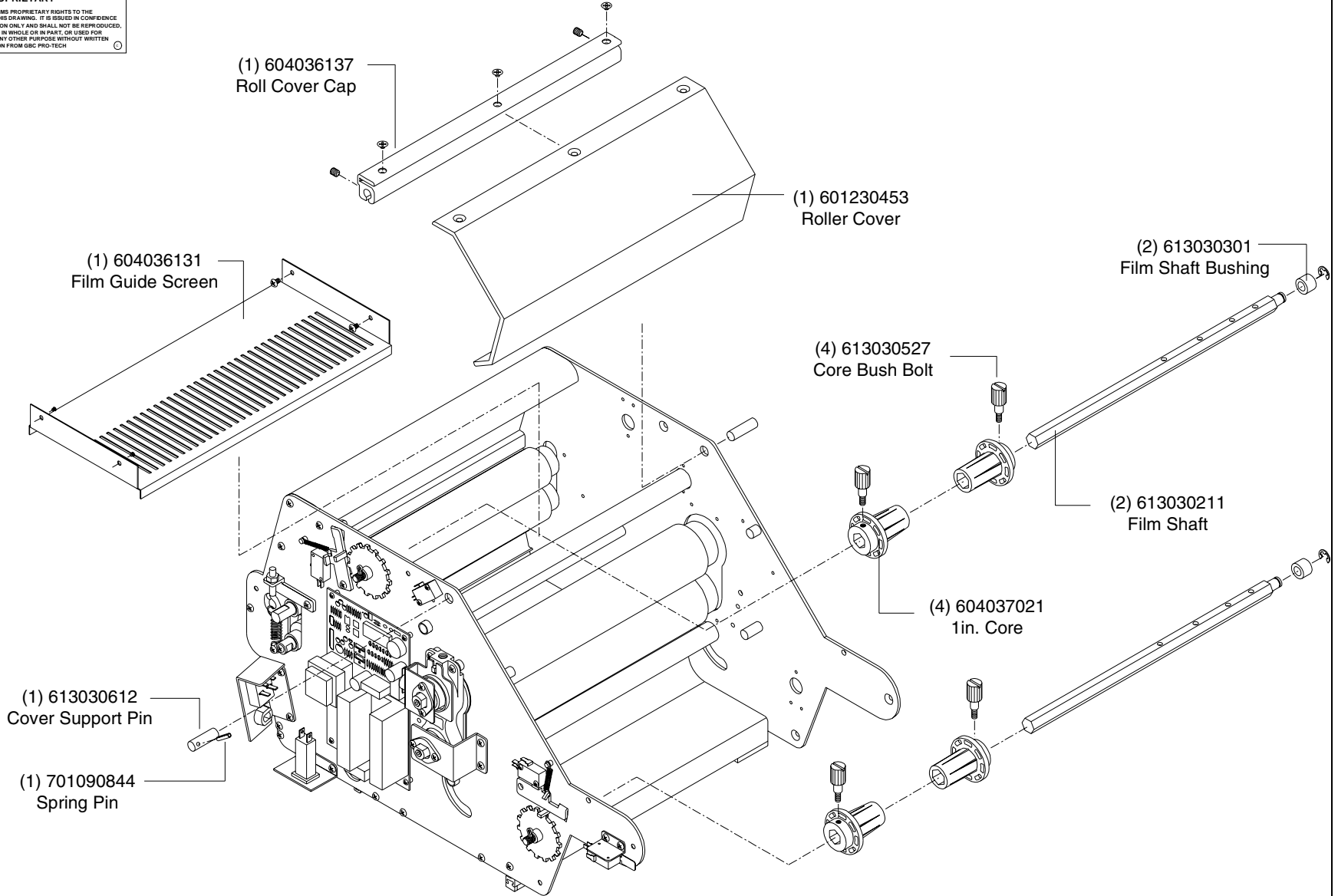

UNLESS OTHERWISE SPECIFIED TOLERANCE				GBC Films Group 4151 Anderson Road, DeForest, WI 53532			
DM. AS SHOWN	TOL.	FINISH TO BE	1/2 √	TITLE : Assembly, Cover And Film Shaft Patriot 25E			
XIX	±.184			DATE :	DRAWN BY :	DWG SCALE :	DWG :
X	±.050			07/01/02	NSG	N/A	P25E-004
XX	±.010			ANGLES A-D			
XXX	±.000						
XXXX	±.005						

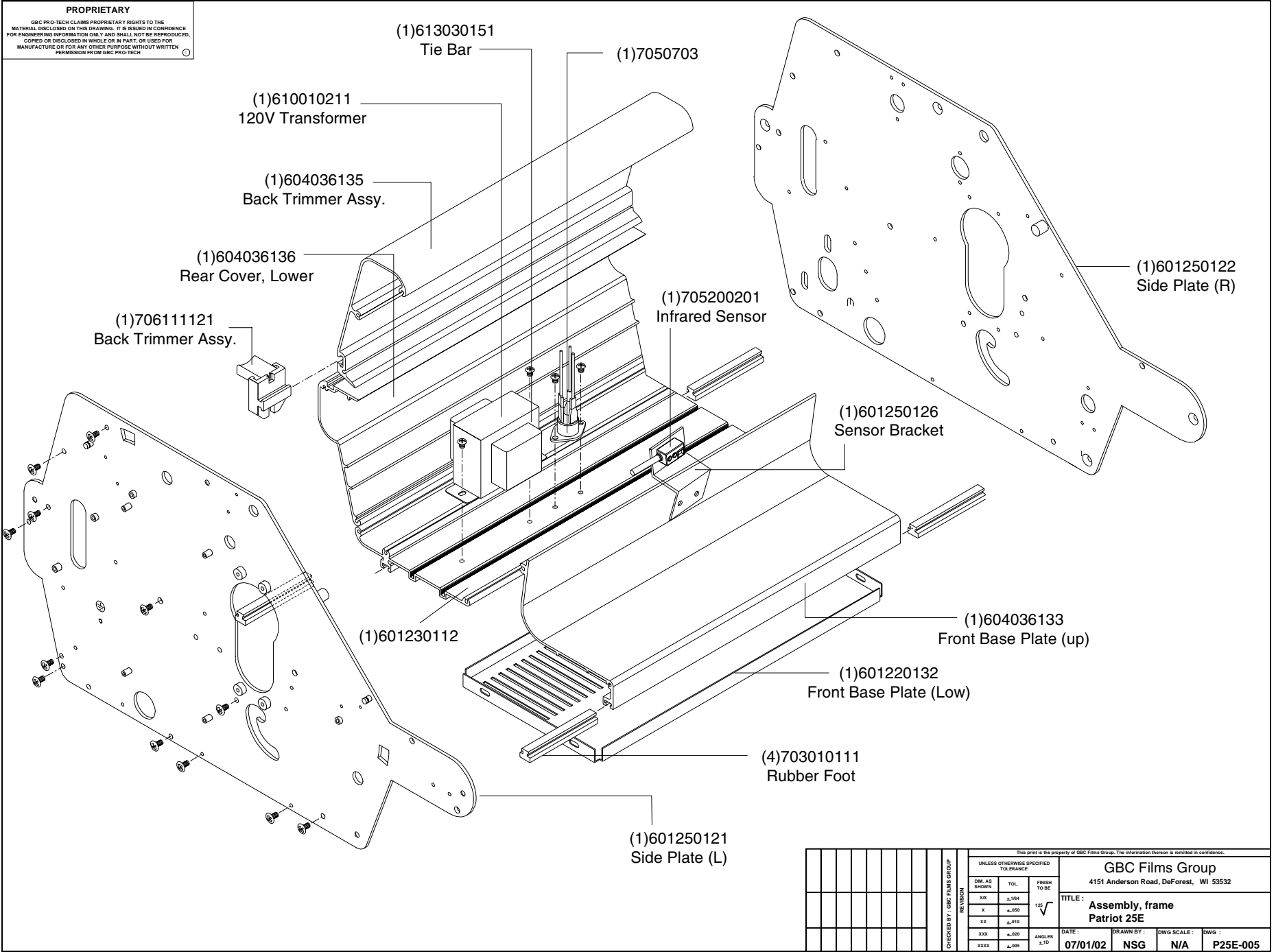

UNLESS OTHERWISE SPECIFIED TOLERANCE				GBC Films Group 4151 Anderson Road, DeForest, WI 53532			
DIM. AS SHOWN	TOL.	FRESH TO BE	1/2√	TITLE: Assembly, frame Patriot 25E			
XX	±.104			DATE: 07/01/02			
X	±.050			DRAWN BY: NSG			
XX	±.010			DWG SCALE: N/A			
XXX	±.002			DWG: P25E-005			
XXXX	±.005	ANGLES ±.10					

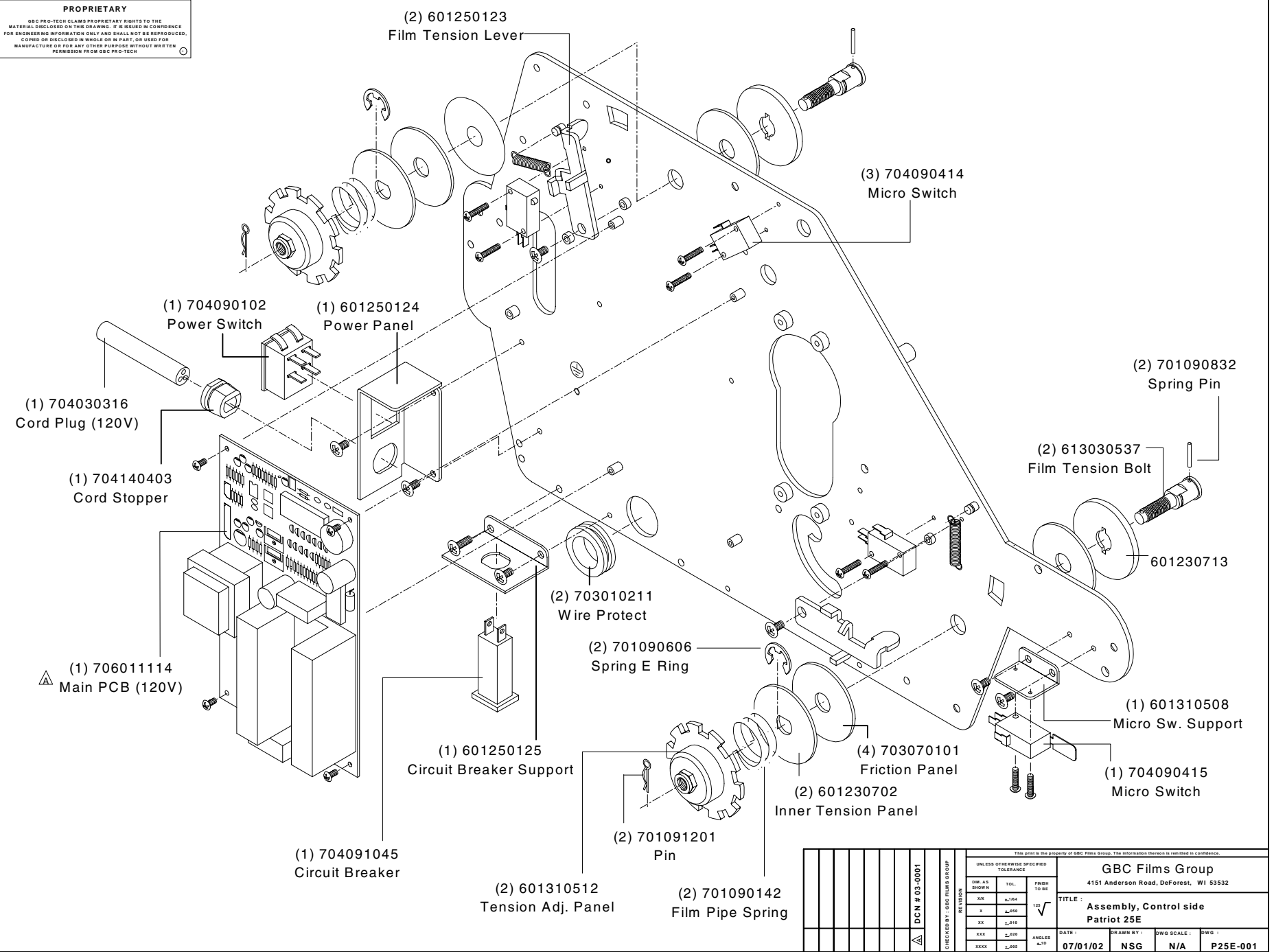

UNLESS OTHERWISE SPECIFIED		TOLERANCE		GBC Films Group													
FINISH TO BE	125	DATE:	07/01/02	DRAWN BY:	NSG												
DATE:	07/01/02	DWG SCALE:	N/A	DWG:	P25E-001												
<small>This print is the property of GBC Films Group. The information hereon is not to be retransmitted in confidence.</small>																	
GBC FILMS GROUP		4151 Anderson Road, DeForest, WI 53532															
TITLE:		Assembly, Control side Patriot 25E															
CHECKED BY: GBC FILMS GROUP		DCN # 03-0001															
REVISION		<table border="1"> <tr> <th>REV.</th> <th>DATE</th> <th>DESCRIPTION</th> </tr> <tr> <td> </td> <td> </td> <td> </td> </tr> <tr> <td> </td> <td> </td> <td> </td> </tr> <tr> <td> </td> <td> </td> <td> </td> </tr> </table>				REV.	DATE	DESCRIPTION									
REV.	DATE	DESCRIPTION															

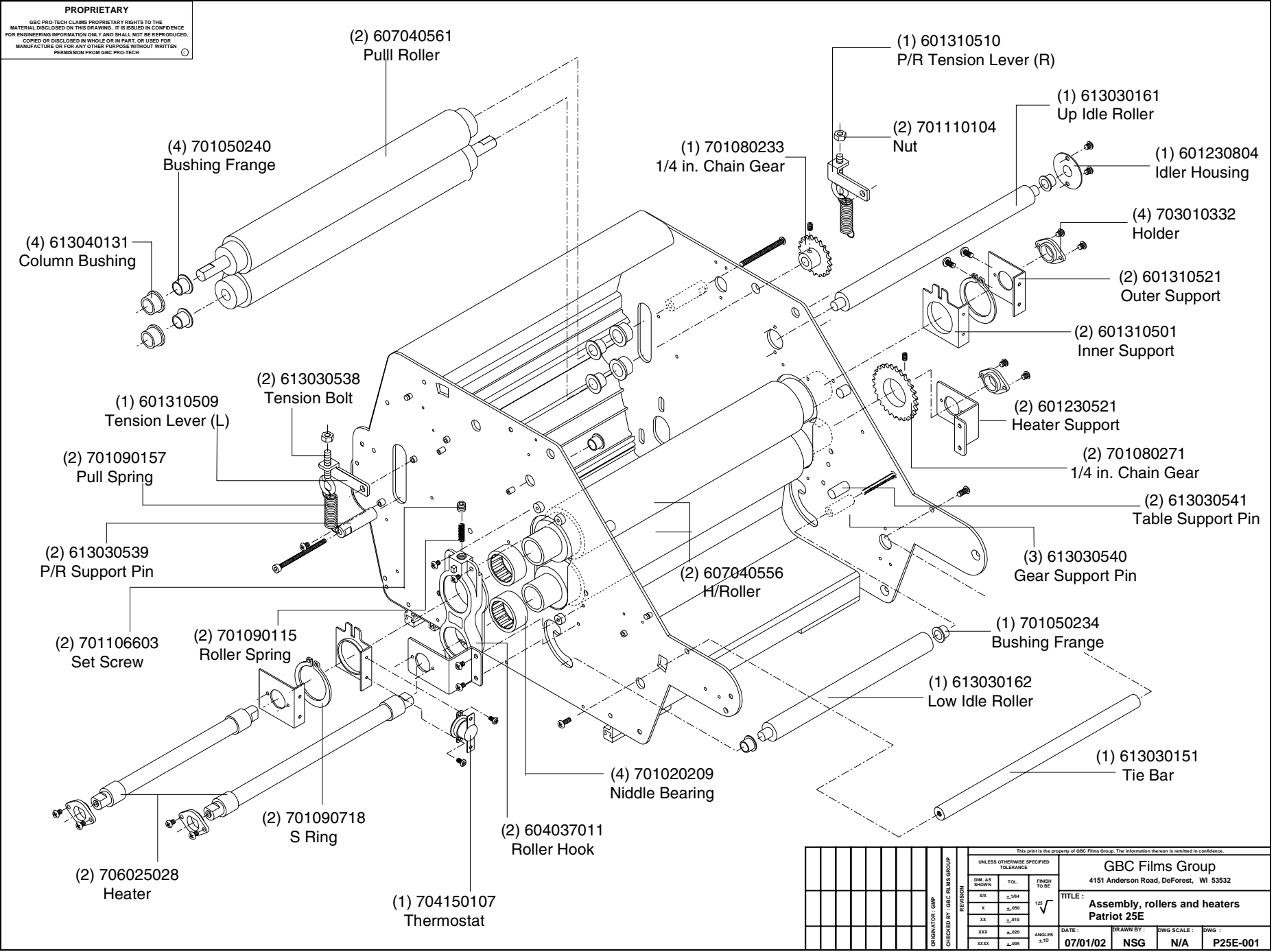

UNLESS OTHERWISE SPECIFIED TOLERANCE				GBC Films Group 4151 Anderson Road, DeForest, WI 53532			
DM. AS SHOWN	TOL.	FINISH TO BE	1/2	TITLE : Assembly, rollers and heaters Patriot 25E			
XIX	±.184			DATE : 07/01/02	DRAWN BY : NSG	DWG SCALE : N/A	DWG : P25E-001
X	±.050			ANGLES : A-D			
XX	±.010						
XXX	±.005						
XXXX	±.005						

PROPRIETARY

GBC PRO TECH CLAIMS PROPRIETARY RIGHTS TO THE MATERIAL DISCLOSED ON THIS DRAWING. IT IS ISSUED IN CONFIDENCE FOR ENGINEERING INFORMATION ONLY AND SHALL NOT BE REPRODUCED, COPIED OR DISCLOSED IN WHOLE OR IN PART, OR USED FOR MANUFACTURE OR FOR ANY OTHER PURPOSE WITHOUT WRITTEN PERMISSION FROM GBC PRO TECH.

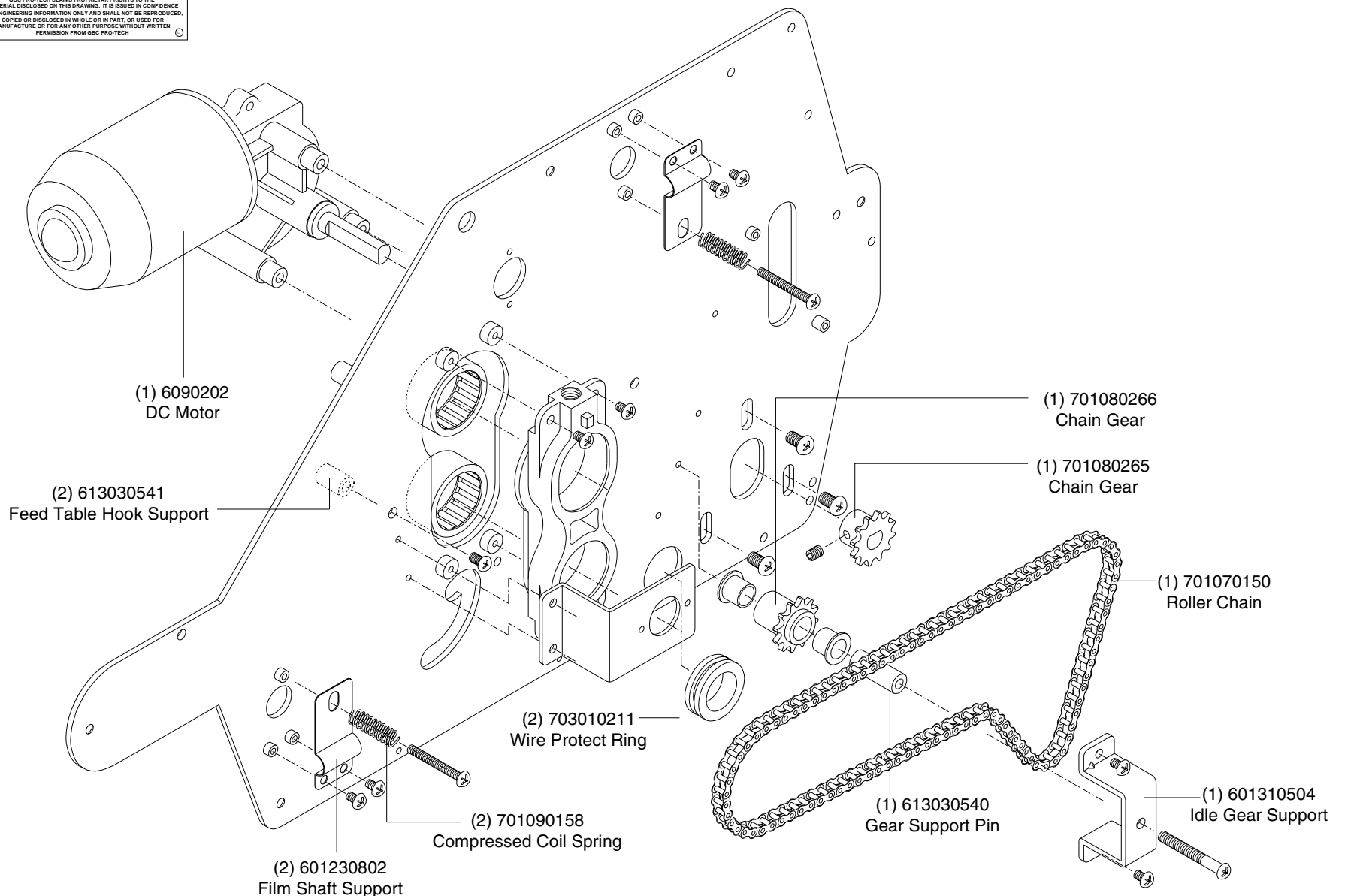

(1) 6090202
DC Motor

(2) 613030541
Feed Table Hook Support

(1) 701080266
Chain Gear

(1) 701080265
Chain Gear

(1) 701070150
Roller Chain

(2) 703010211
Wire Protect Ring

(2) 701090158
Compressed Coil Spring

(2) 601230802
Film Shaft Support

(1) 613030540
Gear Support Pin

(1) 601310504
Idle Gear Support

UNLESS OTHERWISE SPECIFIED TOLERANCE				GBC Films Group 4151 Anderson Road, DeForest, WI 53532			
DM. AS SHOWN	TOL.	FINISH TO BE		TITLE : Assembly, drive side Patriot 25E			
XIX	±.184	1/2 √		DATE :	DRAWN BY :	DWG SCALE :	DWG :
X	±.050			07/01/02	NSG	N/A	P25E-008
XX	±.010			ANGLES A-D			
XXX	±.000						
XXXX	±.005						

PROPRIETARY
 GBC PRO-TECH CLAIMS PROPRIETARY RIGHTS TO THE MATERIAL DISCLOSED ON THIS DRAWING. IT IS ISSUED IN CONFIDENCE FOR ENGINEERING INFORMATION ONLY AND SHALL NOT BE REPRODUCED, COPIED OR DISCLOSED IN WHOLE OR IN PART, OR USED FOR MANUFACTURE OR FOR ANY OTHER PURPOSE WITHOUT WRITTEN PERMISSION FROM GBC PRO-TECH.

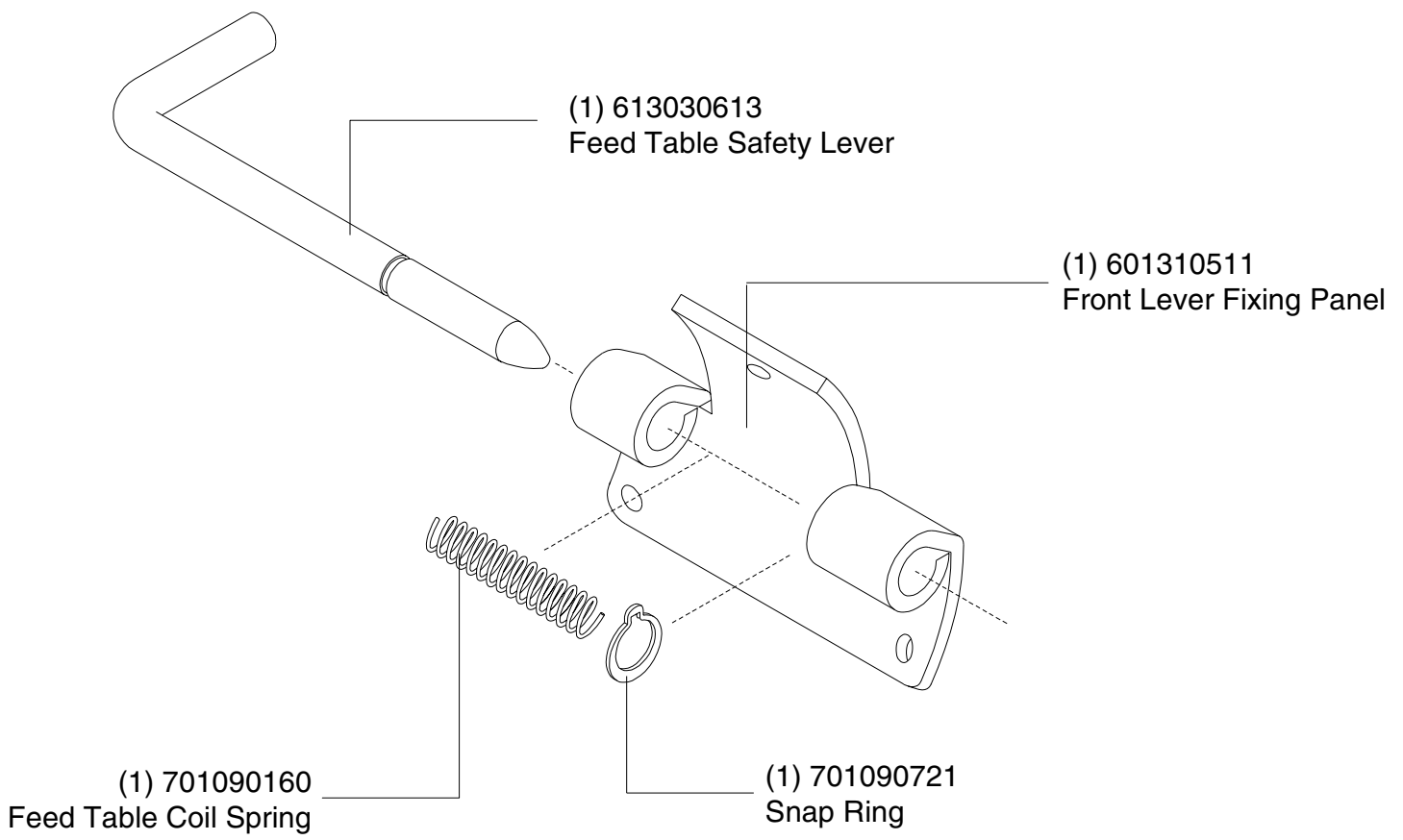

UNLESS OTHERWISE SPECIFIED TOLERANCE				GBC Films Group 4151 Anderson Road, DeForest, WI 53532			
DM. AS SHOWN	TOL.	FINISH TO BE	1/2 √	TITLE : Assembly, Latch Patriot 25E			
XX	±.184			DATE :	DRAWN BY :	DWG SCALE :	DWG :
X	±.050			07/01/02	NSG	N/A	P25E-009
XX	±.010						
XXX	±.020	ANGLES					
XXXX	±.005	±.0°					

PROPRIETARY
 GBC PRO-TECH CLAIMS PROPRIETARY RIGHTS TO THE MATERIAL DISCLOSED ON THIS DRAWING. IT IS ISSUED IN CONFIDENCE FOR ENGINEERING INFORMATION ONLY AND SHALL NOT BE REPRODUCED, COPIED OR DISCLOSED IN WHOLE OR IN PART, OR USED FOR MANUFACTURE OR FOR ANY OTHER PURPOSE WITHOUT WRITTEN PERMISSION FROM GBC PRO-TECH

PATRIOT 25E WIRE DIAGRAM(120/60)

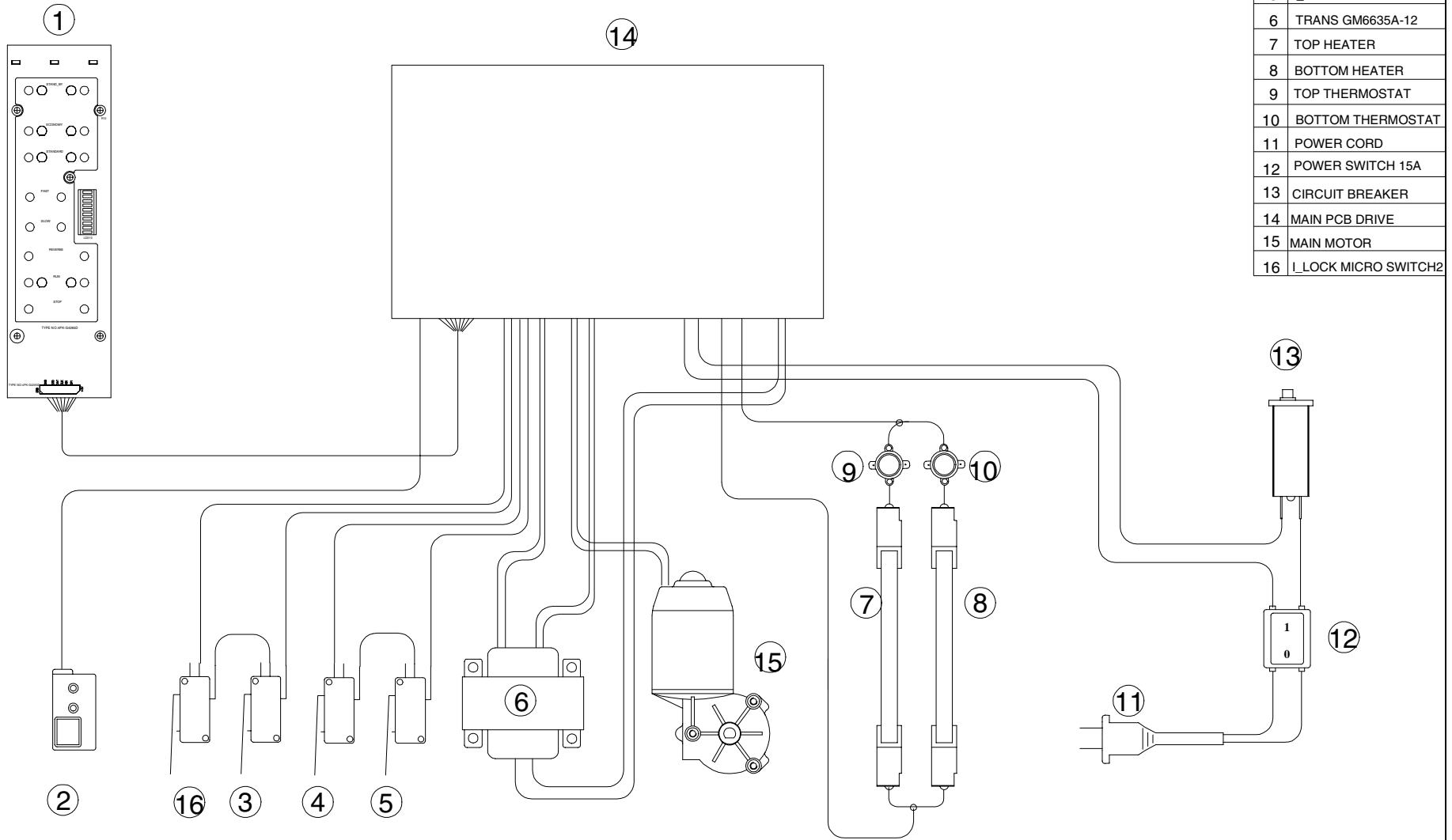

1	DISPALY PCB
2	TOP IR SENSOR
3	TABLE MICRO SWITCH 1
4	TABLE MICRO SWITCH 2
5	L_LOCK MICRO SWITCH1
6	TRANS GM6635A-12
7	TOP HEATER
8	BOTTOM HEATER
9	TOP THERMOSTAT
10	BOTTOM THERMOSTAT
11	POWER CORD
12	POWER SWITCH 15A
13	CIRCUIT BREAKER
14	MAIN PCB DRIVE
15	MAIN MOTOR
16	L_LOCK MICRO SWITCH2

UNLESS OTHERWISE SPECIFIED TOLERANCE			
DWG. AS SHOWN	TOL.	FINISH TO BE	
XX	±.184	125	✓
X	±.250		
XX	±.019		
XXX	±.020	ANGLES	±.1°
XXXX	±.065		

GBC Films Group	
4151 Anderson Road, DeForest, WI 53532	
TITLE: Patriot25E Wire Diagram (120/60)	
DATE: 07/01/02	DRAWN BY: NSG
DWG SCALE: N/A	DWG: P25E-010

This page intentionally left blank.



General Binding Corporation
One GBC Plaza
Northbrook, IL 60062-4195