



1256S / 1656S-2 PARTS LIST



GBC IS AN ACCO BRANDS COMPANY

Section 8.0 1256S-2/1656S-2 Parts List
Exploded View
Figure 8.1

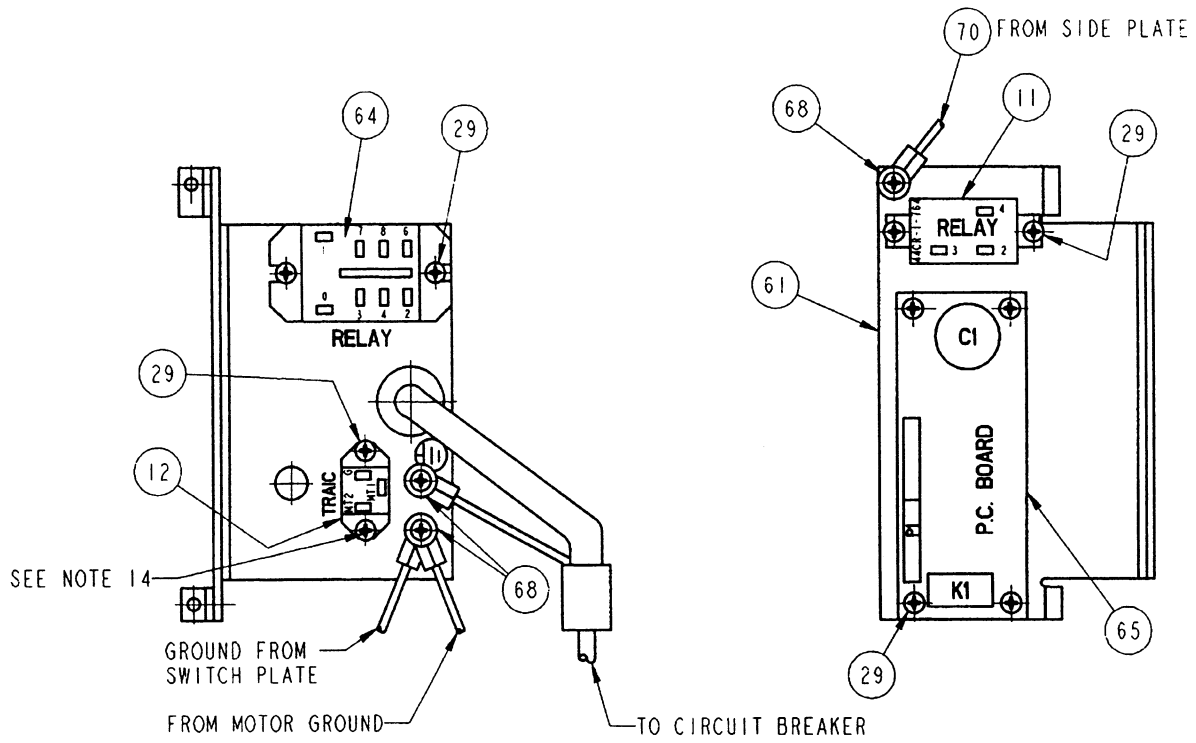

POWER BRACKET DETAIL-S

SCALE-1/2"

Section 8.0 1256S-2/1656S-2 Parts List
Exploded View
Figure 8.2

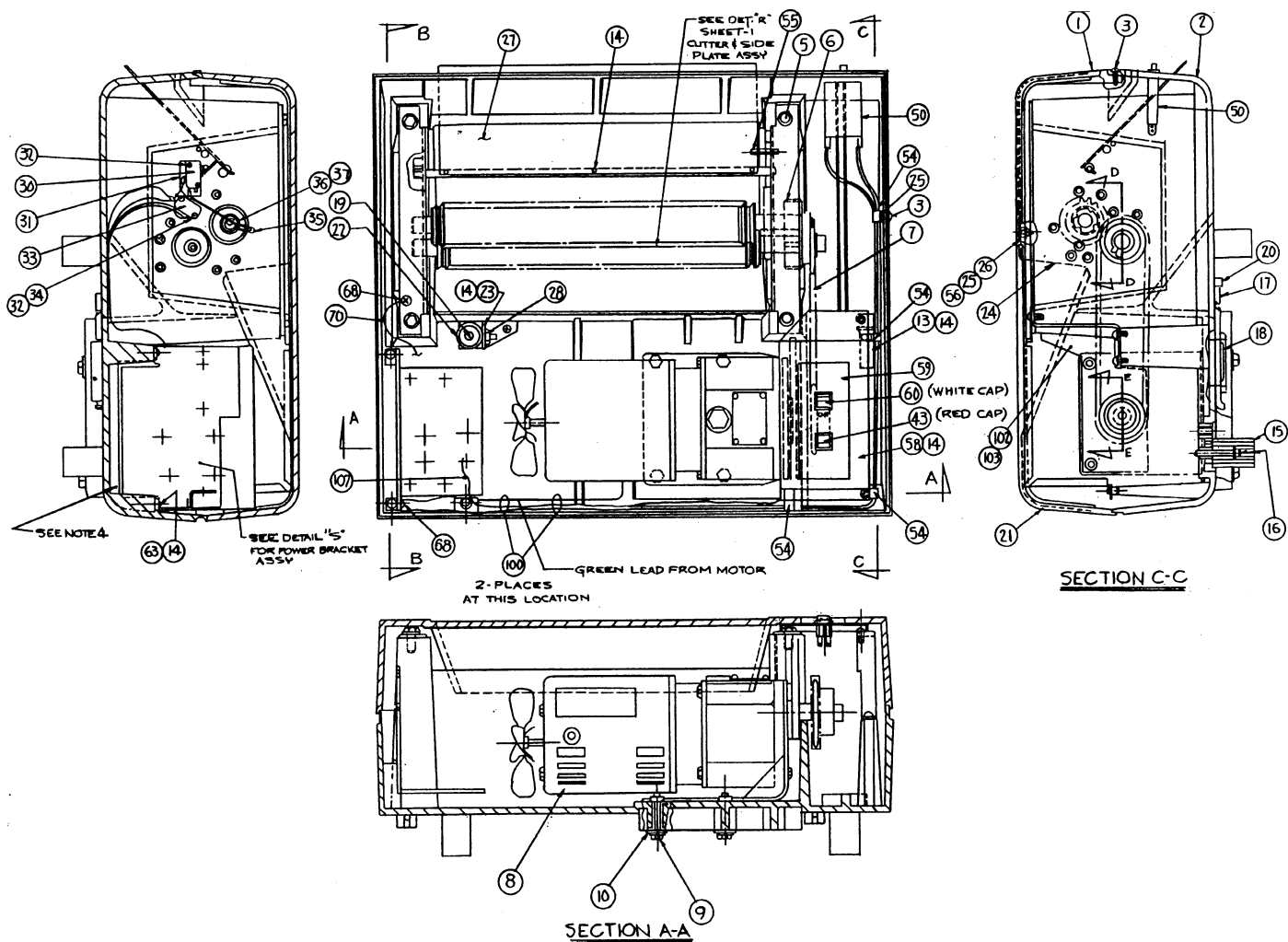

Section 8.0 1256S-2/1656S-2Parts List
Exploded View
Figure 8.3

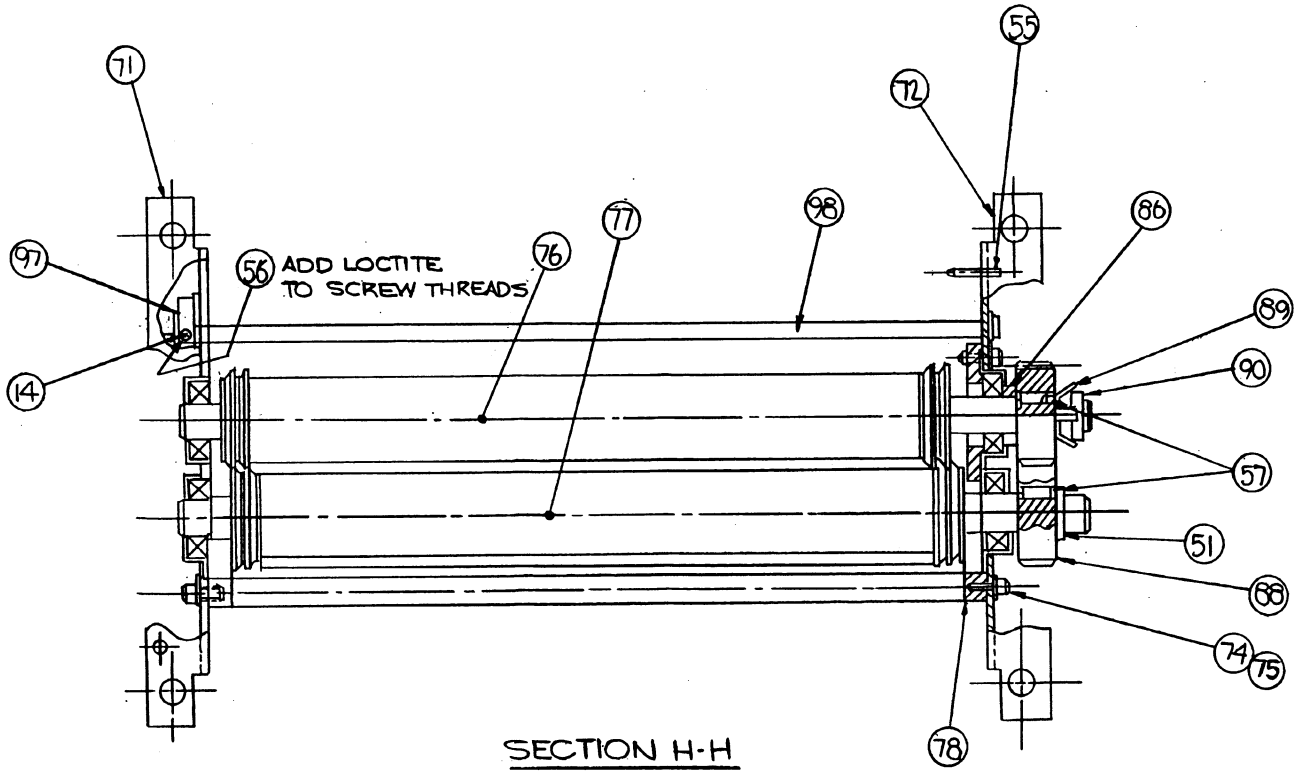

SECTION H-H

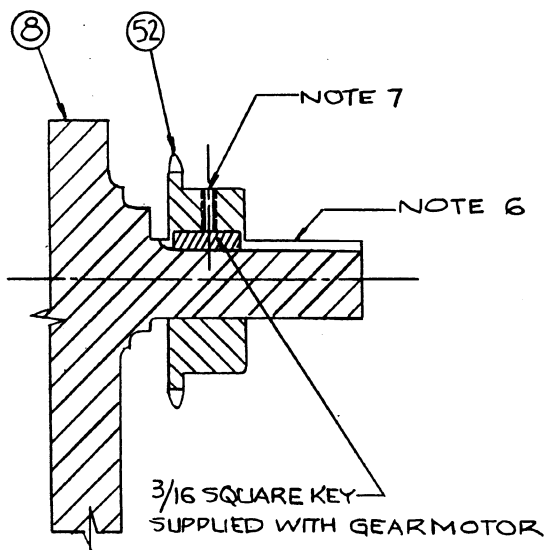

SECTION E-E

Section 8.0 1256S-2/1656S-2Parts List
Exploded View
Figure 8.4

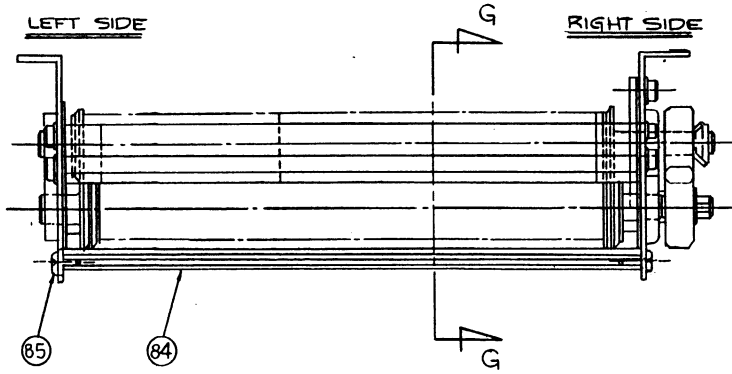

DETAIL "R"
CUTTER & SIDE PLATE ASSEMBLY

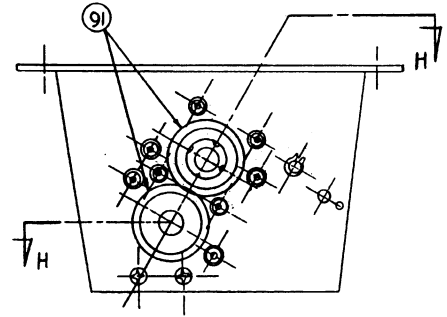

SEE DETAIL R- SHT. 1
CUTTER & SIDE PLATES
ASSY.

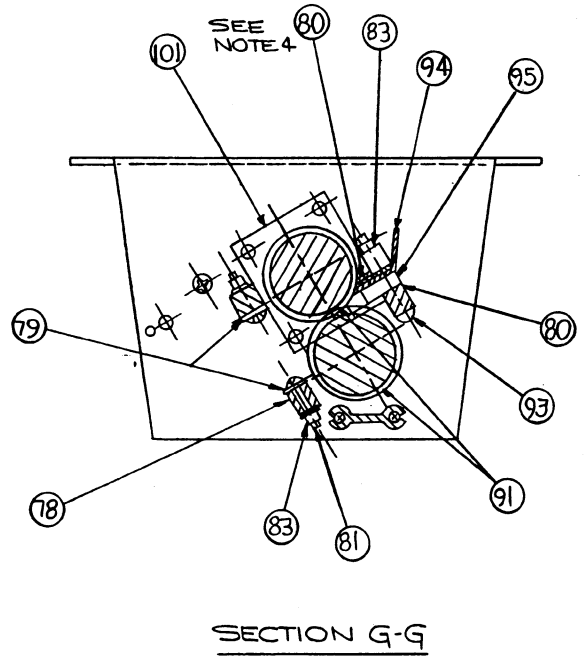
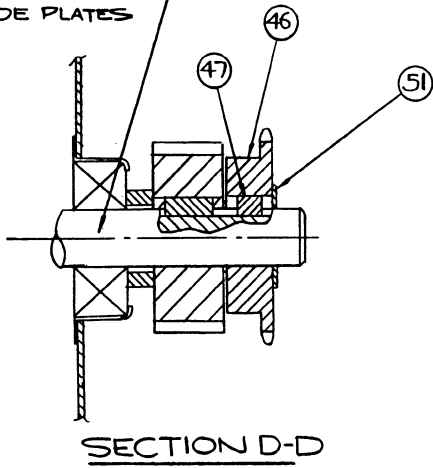

Section 8.0 1256S-2 Parts List B.O.M

60	1146830	ROCKER SWITCH, ON	1
59	7500633	SWITCH DECAL	1
58	1146853	SWITCH BRACKET	1
57	1852807	3/16" SQUARE KEY X 1/2"	2
56	1960525	LOCTITE-SUPERBOND	.0001
55	1929224	SPRING PIN	1
54	1931005	CABLE CLAMPS CIRCULAR TYPE	4
53	1954801	THERMAL COMPOUND (GREASE)	.0001
52	1146905	SPROCKET 16T <i>motor</i>	1
51	1931605	GRIP RING 5/8" DIA.	2
50	1145245	CIRCUIT BREAKER 16A	1
49			
48			
47	1852817	3/16" SQUARE KEY X 3/8"	1
46	1146780	SPROCKET 18T (REWORKED)	1
45	6002045	ENGINEERING SPEC.	1
44	7500613	SCHEMATIC DIAGRAM	1
43	1146829	ROCKER SWITCH, OFF	1
42	1952414	STRAIN RELIEF	1
41	6200056	POWER CORD	1
40			
39			
38	1119440	CONNECTOR	4
37	1925009	WASHER, FLAT #10	1
36	1900556	SCREW 10-32 X 5/16" SHCS	1
35	1131146	ACTUATOR	1
34	1145694	STANDOFF, HEX.	2
33	1139322	MICROSWITCH, RREVERSE	1
32	1902834	SCREW 4-40 X 5/8" PHCR	4
31	1146539	INSULATION	1
30	1131147	MICROSWITCH, FLAP	1
29	1907902	SCREW 6-32 X 3/8" THD. CUT'G	10
28	1926802	NUT 8-32 (KEPS)	1
27	1145402	PLASTIC GUARD	1
26	1925035	WASHER, FLAT #8	2
25	1926801	NUT #6-32 (KEPS)	3
24	7500632	TOP SHIELD	1
23	7500637	BRACKET CAPACITOR	1
22	6210080	MOUNTING STRAP CAPACITOR	1
21	7500634	FRONT LABEL	1
20	1145247	PLASTIC CAP SVC	2
19	6205034	START CAPACTOR	1
18	1145231	SPRING SVC	2
17	7500636	ROD, BAG	2
16	1900537	SCREW 1/4-20 X 1-3/4" SHCS	4
15	6176016	RUBBER FOOT	4
14	1911106	SCREW 8-32 X 3/8" (SEMS)	14
13	1145754	BRACKET, SWITCH	1
12	1152315	TRIAC	1
11	6204010	START RELAY (4CR-1-764)	1
10	1925025	WASHER, FLAT 5/16"	4
9	1951978	SCREW 5/16-18 X 2"	4
8	6208064	GEARMOTOR	1
7	1146904	CHAIN 3/8" PITCH	1
6	1961503	GREASE	.001
5	1903205	SCREW 5/16-18 X 3/4"	4
4			
3	1146769	SCREW W/PLASTIC WASHER	5
2	7500631	BOTTOM COVER	1
1	7500630	TOP COVER	1
ITEM	PART No.	DESCRIPTION	QTY.

108	1956962	LEAD & TERM. ASSY (BLK)	1
107	1956961	LEAD & TERM. ASSY (BLK)	1
106	1956966	LEAD & TERM. ASSY (ORN)	1
105			
104	1956964	LEAD & TERM. ASSY (WHT/ORN)	1
103	1900539	SCREW 1/4-20 X 1-1/4"	2
102	1146901	PLATE SUPPORT-CAST	1
101	1145929	RETAINER, BEARING	1
100	1932121	WIRE TIE	16
99	7500644	HARNESS-POWER	1
98	1145973	BAR-GUARD	1
97	1145975	ACTUATOR, FLAP-SWITCH	1
96	1146867	LEAD & TERM ASSY (WHT/GRN)	1
95	1145995	FOLDING BLOCK	2
94	7500635	FRONT DEFLECTOR	1
93	1902855	SCREW 10-32 X 1-3/4" PAN HD	2
92			
91	1145180	BALL BEARINGS, CUTTER	4
90	1145930	LOCKNUT 5/16-32"	1
89	1145931	LOCKWASHER	1
88	1145976	GEAR, CUTTER	2
87	1956985	LEAD & TERM. ASSY (BLK)	1
86	1145928	SPACER, CUTTER	1
85	1907818	SCREW 10-32 X 5/8" THD CUT'G	4
84	1145799	GUARD, SPACER	1
83	1926822	L'NUT #10-32 (SERRATED FLANGE)	10
82			
81	1903033	SCREW 10-32 X 7/8" TRUSS HD.	8
80	1145922	FRONT STRIPPER	2
79	1145921	BACK STRIPPER	2
78	1145882	BAR SUPPORT, STRIPPER	4
77	1146909	LOWER CUTTER	1
76	1145878	UPPER CUTTER	1
75	1926002	SPRING, LOCKWASHER	12
74	1900512	SCREW 1/4-20 X 1/2" SOC. HD	12
73			
72	1145920	PLATE-RIGHT SIDE	1
71	1145919	PLATE-LEFT SIDE	1
70	1146888	LEAD & TERM ASSY GRN	1
69	1146877	LEAD & TERM ASSY GRN	1
68	1908509	SCREW 8-32 X 1/2"	4
67			
66			
65	7500620	P.C. BOARD	1
64	6204011	RELAY-SHREDDER	1
63	7500640	BRACKET-WIRE	1
62	1146855	SUPPORT-P.C. BOARD	4
61	7500645	BRACKET-POWER	1
ITEM	PART No.	DESCRIPTION	QTY.

Section 8.0 1656S-2 Parts List B.O.M

60	1146830	ROCKER SWITCH, ON	1
59	7500633	SWITCH DECAL	1
58	1146853	SWITCH BRACKET	1
57	1852807	3/16" SQUARE KEY X 1/2"	2
56	1960525	LOCTITE-SUPERBOND	.0001
55	1929224	SPRING PIN	1
54	1931005	CABLE CLAMPS CIRCULAR TYPE	4
53	1954801	THERMAL COMPOUND (GREASE)	.0001
52	1146905	SPROCKET 16T	1
51	1931605	GRIP RING 5/8" DIA.	2
50	1145245	CIRCUIT BREAKER 16A	1
49			
48			
47	1852817	3/16" SQUARE KEY X 3/8"	1
46	1146780	SPROCKET 18T (REWORKED)	1
45	6002046	ENGINEERING SPEC.	1
44	7500613	SCHEMATIC DIAGRAM	1
43	1146829	ROCKER SWITCH, OFF	1
42	1952414	STRAIN RELIEF	1
41	6200056	POWER CORD	1
40			
39			
38	1119440	CONNECTOR	4
37	1925009	WASHER, FLAT #10	1
36	1900562	SCREW 10-32 X 1/2" SHCS	1
35	1131146	ACTUATOR	1
34	1145694	STANDOFF, HEX.	2
33	1139322	MICROSWITCH, RREVERSE	1
32	1902834	SCREW 4-40 X 5/8" PHCR	4
31	1146539	INSULATION	1
30	1131147	MICROSWITCH, FLAP	1
29	1907902	SCREW 6-32 X 3/8" THD. CUT'G	10
28	1926802	NUT 8-32 (KEPS)	1
27	1145405	PLASTIC GUARD	1
26	1925035	WASHER, FLAT #8	2
25	1926801	NUT #6-32 (KEPS)	3
24	7500832	TOP SHIELD	1
23	7500637	BRACKET CAPACITOR	1
22	6210080	MOUNTING STRAP CAPACITOR	1
21	7501031	FRONT LABEL	1
20	1145247	PLASTIC CAP SVC	2
19	6205034	START CAPACITOR, 108uF 220VAC	1
18	1145231	SPRING SVC	2
17	7500636	ROD, BAG	2
16	1900537	SCREW 1/4-20 X 1-3/4" SHCS	4
15	6176016	RUBBER FOOT	4
14	1911106	SCREW 8-32 X 3/8" (SEMS)	14
13	1145754	BRACKET, SWITCH	1
12	1152315	TRIAC	1
11	6204010	START RELAY (4CR-1-764)	1
10	1925025	WASHER, FLAT 5/16"	4
9	1951978	SCREW 5/16-18 X 2"	4
8	6208064	GEARMOTOR	1
7	1146904	CHAIN 3/8" PITCH	1
6	1961503	GREASE	.001
5	1903205	SCREW 5/16-18 X 3/4"	4
4			
3	1146769	SCREW W/PLASTIC WASHER	5
2	7500831	BOTTOM COVER	1
1	7500830	TOP COVER	1
ITEM	PART No.	DESCRIPTION	QTY.

108	1956962	LEAD & TERM. ASSY (BLK)	1
107	1956961	LEAD & TERM. ASSY (BLK)	1
106	1956966	LEAD & TERM. ASSY (ORN)	1
105			
104	1956964	LEAD & TERM. ASSY (WHT/ORN)	1
103	1900539	SCREW 1/4-20 X 1-1/4"	2
102	1146901	PLATE SUPPORT-CAST	1
101	1145929	RETAINER, BEARING	1
100	1932121	WIRE TIE	16
99	7500644	HARNESS-POWER	1
98	1145974	BAR-GUARD	1
97	1145975	ACTUATOR, FLAP-SWITCH	1
96	1146867	LEAD & TERM ASSY (WHT/GRN)	1
95	1145995	FOLDING BLOCK	2
94	7500835	FRONT DEFLECTOR	1
93	1902855	SCREW 10-32 X 1-3/4" PAN HD	2
92			
91	1145180	BALL BEARINGS, CUTTER	4
90	1145930	LOCKNUT 5/16-32"	1
89	1145931	LOCKWASHER	1
88	1145976	GEAR, CUTTER	2
87	1956985	LEAD & TERM. ASSY (BLK)	1
86	1145928	SPACER, CUTTER	1
85	1907818	SCREW 10-32 X 5/8" THD CUT'G	4
84	1145798	GUARD, SPACER	1
83	1926822	L'NUT #10-32 (SERRATED FLANGE)	12
82			
81	1903033	SCREW 10-32 X 7/8" TRUSS HD.	8
80	1145926	FRONT STRIPPER	2
79	1145925	BACK STRIPPER	2
78	1145927	BAR SUPPORT, STRIPPER	4
77	1146910	LOWER CUTTER	1
76	1145895	UPPER CUTTER	1
75	1926002	SPRING, LOCKWASHER	12
74	1900512	SCREW 1/4-20 X 1/2" SOC. HD	12
73			
72	1145920	PLATE-RIGHT SIDE	1
71	1145919	PLATE-LEFT SIDE	1
70	1146888	LEAD & TERM ASSY GRN	1
69	1146877	LEAD & TERM ASSY GRN	1
68	1908509	SCREW 8-32 X 1/2"	4
67			
66			
65	7500620	P.C. BOARD	1
64	6204011	RELAY-SHREDDER	1
63	7500640	BRACKET-WIRE	1
62	1146855	SUPPORT-P.C. BOARD	4
61	7500645	BRACKET-POWER	1
ITEM	PART No.	DESCRIPTION	QTY.