



# 1246S-2 PARTS LIST



GBC IS AN ACCO BRANDS COMPANY

**GBC® Shredmaster**

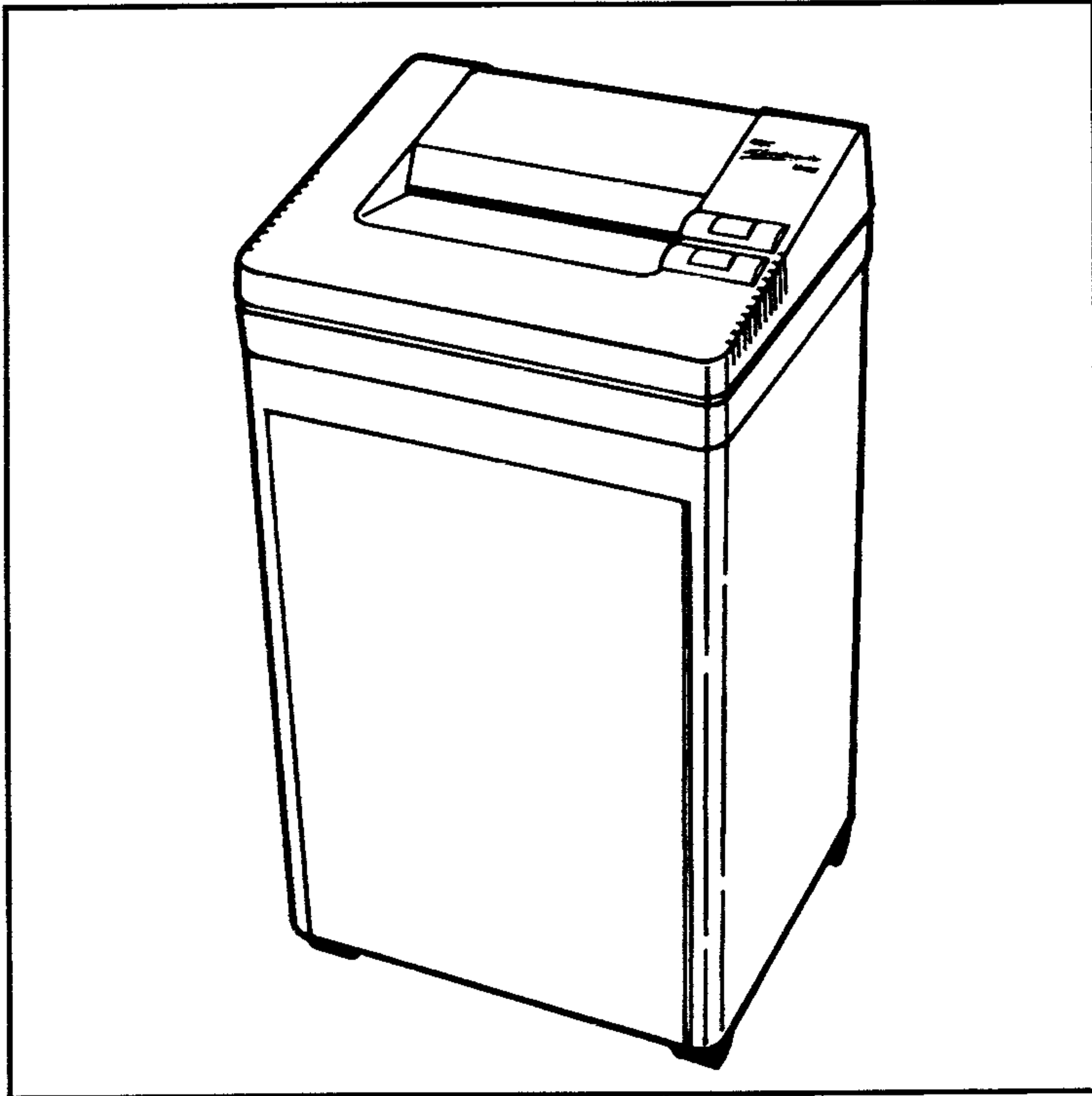

Parts Manual

Models 1246S-2

Double stop switch

8.0 1246S-1 Parts List  
8.1 "Exploded View"

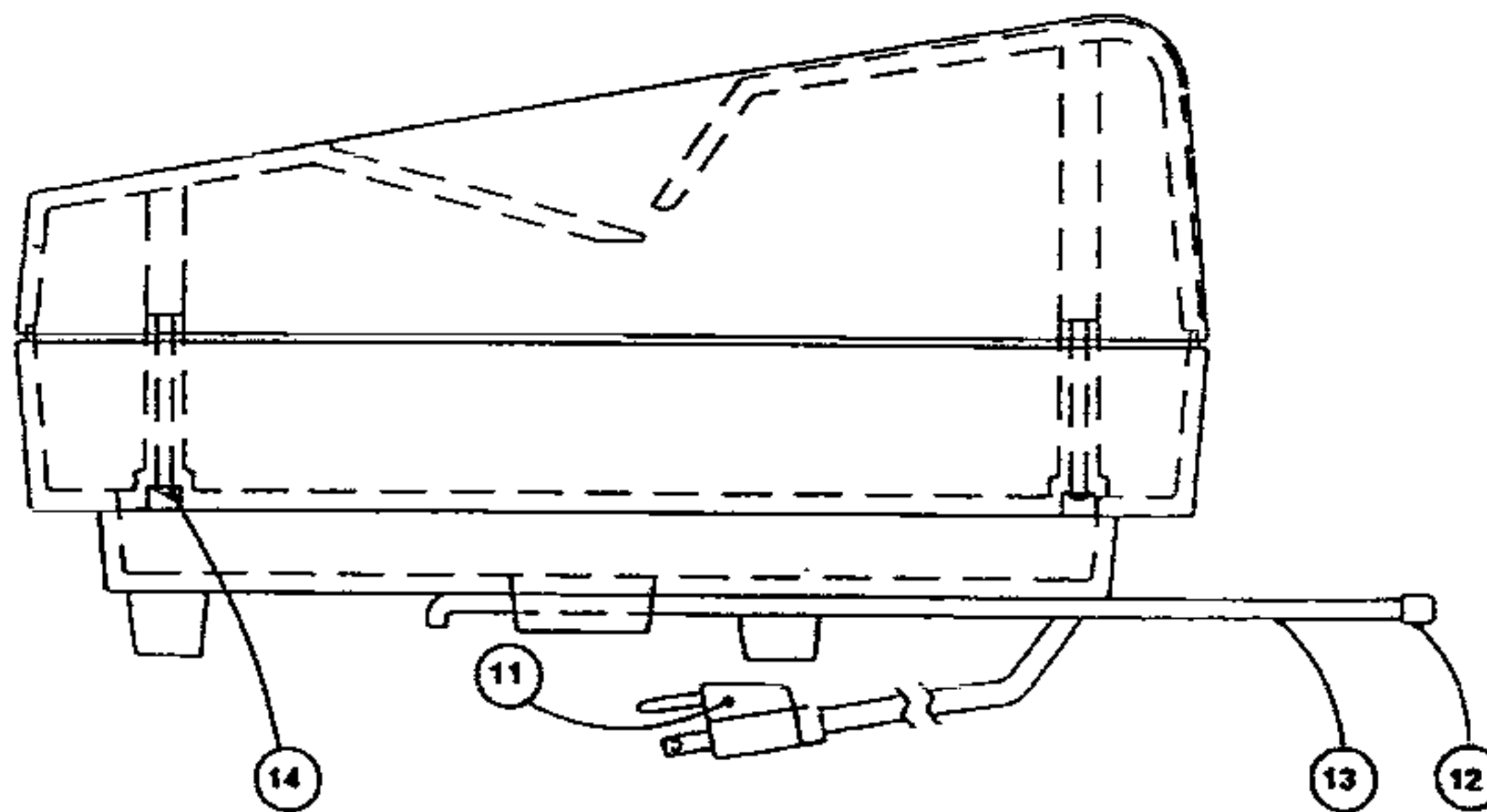
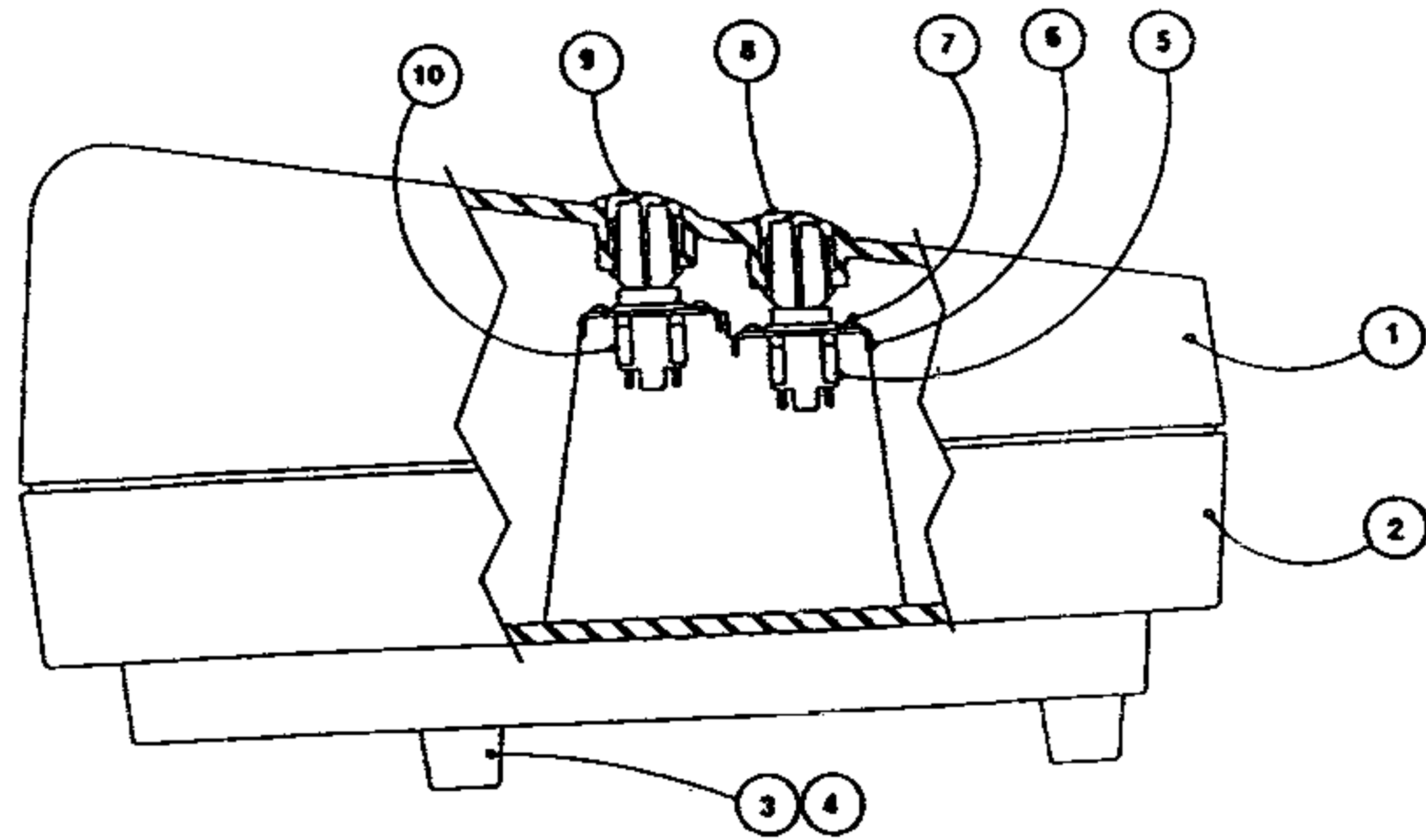

## 8.0 1246S-1 Parts List

### 8.1 "Exploded View"

ITEM	PART NO.	DESCRIPTION	QTY.
1	7500430	TOPSHELL	1
2	7500431	BOTTOM SHELL	1
3	7500050	RUBBERFOOT	4
4	1902827	SCREW 10-32 X 3/4	4
5	7500033	OFF/REVERSE SWITCH	2
6	7500037	SWITCH MTG. BRACKET	1
7	1911109	SCREW 6-32 X 1/4	3
8	7500043	BUTTON CAP-OFF SWITCH	1
9	7500030	BUTTON CAP-ON SWITCH	1
10	7500044	ON-SWITCH	1
11	6200000	POWER CORD SET	1
12	1145247	PLASTIC CAP	2
13	7500041	BAGROD	2
14	1902813	SCREW 8-32 X 1-1/4	4

8.0 PARTS  
Figure 8.2

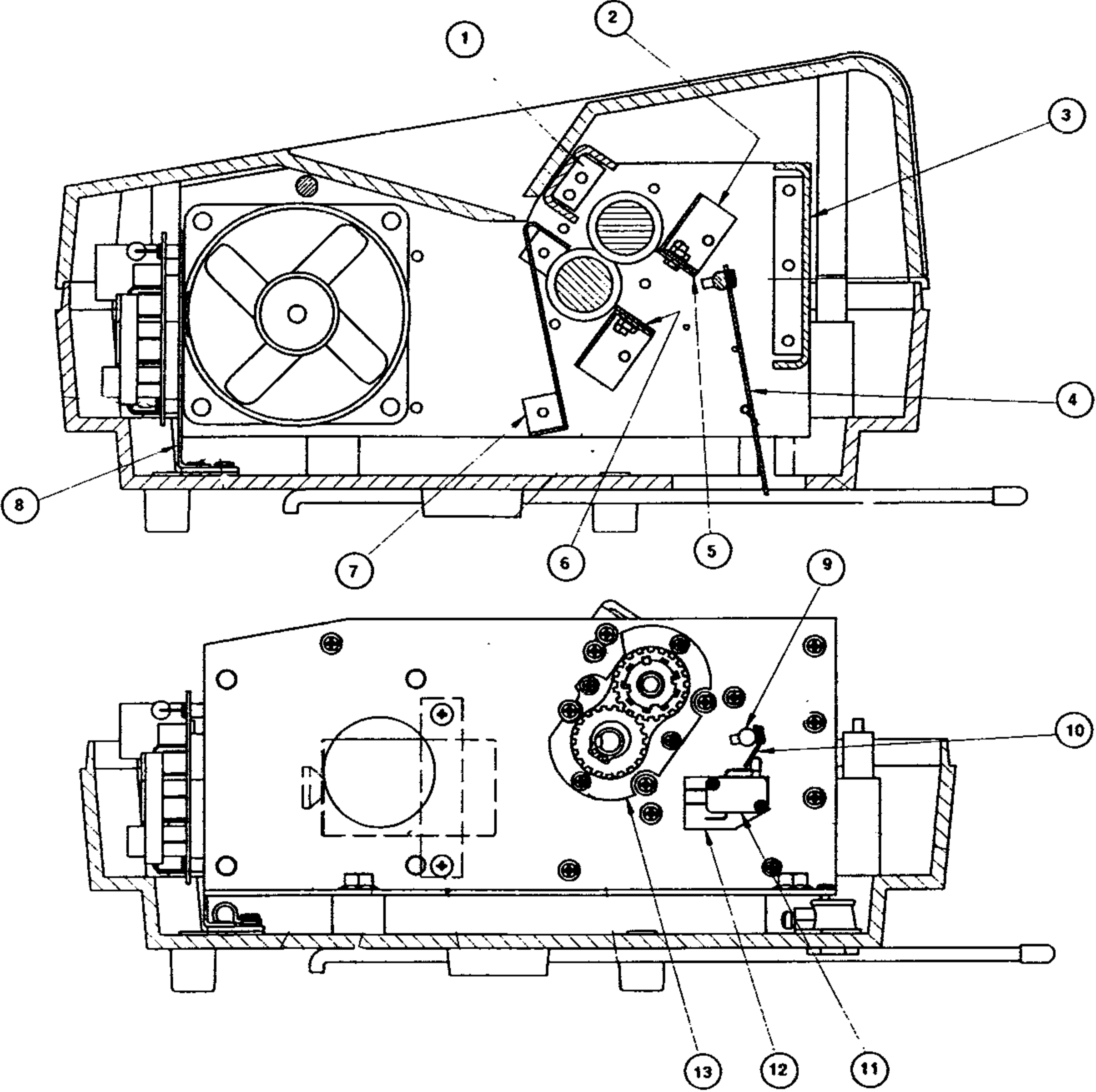

## 8.0 PARTS

Figure 8.2

ITEM	PART NO.	DESCRIPTION	QTY.
1	7500445	UPPER PAPER GUIDE	1
2	7500435	SUPPORT, STRIPPER	2
3	7500450	BACK CROSS PLATE	1
4	7500443	GUARD	1
5	7500434	STRIPPER, UPPER	1
6	7500433	STRIPPER, LOWER	1
7	7500470	LOWER PAPER GUIDE	1
8	7500231	MOUNTING BRACKET, PCB	1
9	7500442	BAR GUARD	1
10	7500047	ACTUATOR, FLAP	1
11	1131147	SNAP SWITCH	1
12	1122005	INSULATION, SNAP SWITCH	1
13	7500481	BEARING CUP	2
14	1954304	HEAT SHRINK SLEEVE	1

**8.0 PARTS**  
Figure 8.3

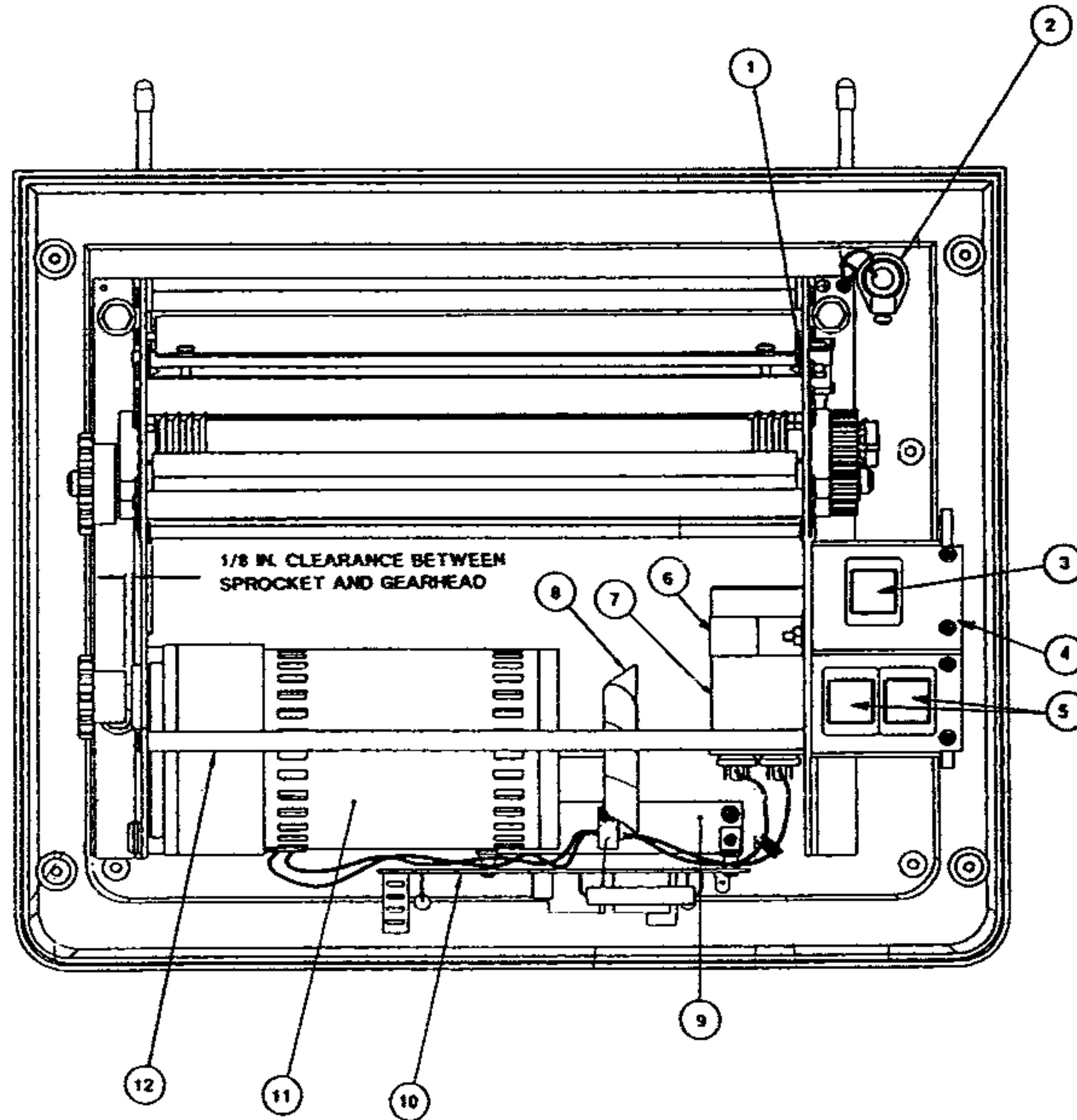

ITEM	PART NO.	DESCRIPTION	QTY.
1	6178016	TORSION SPRING	1
2	1952414	STRAIN RELIEF	1
3	-Ref-	SWITCH ON (see Fig. 8.1 #8)	1
4	-Ref-	BRA KET, SWITCH (see Fig. 8.1 #6)	2
5	-Ref-	SWITCH, OFF/REVERSE (see Fig 8.1 #5)	1
6	1145205	STRAP, CAPACITOR	1
7	6205016	CAPACITOR, 30mf	1
8	7500491	FAN BLADE	1
9	7500488	MOUNTING PLATE, P.C. BOARD	1
10	7500414	P.C. BOARD ASSY	1
11	6208031	GEAR MOTOR 1/4 HP	1
12	7500486	BAR SUPPORT	1
13	1963701	O RING	1
14	7500492	PLASTIC CHANNEL	1

8.0 PARTS  
Figure 8.4

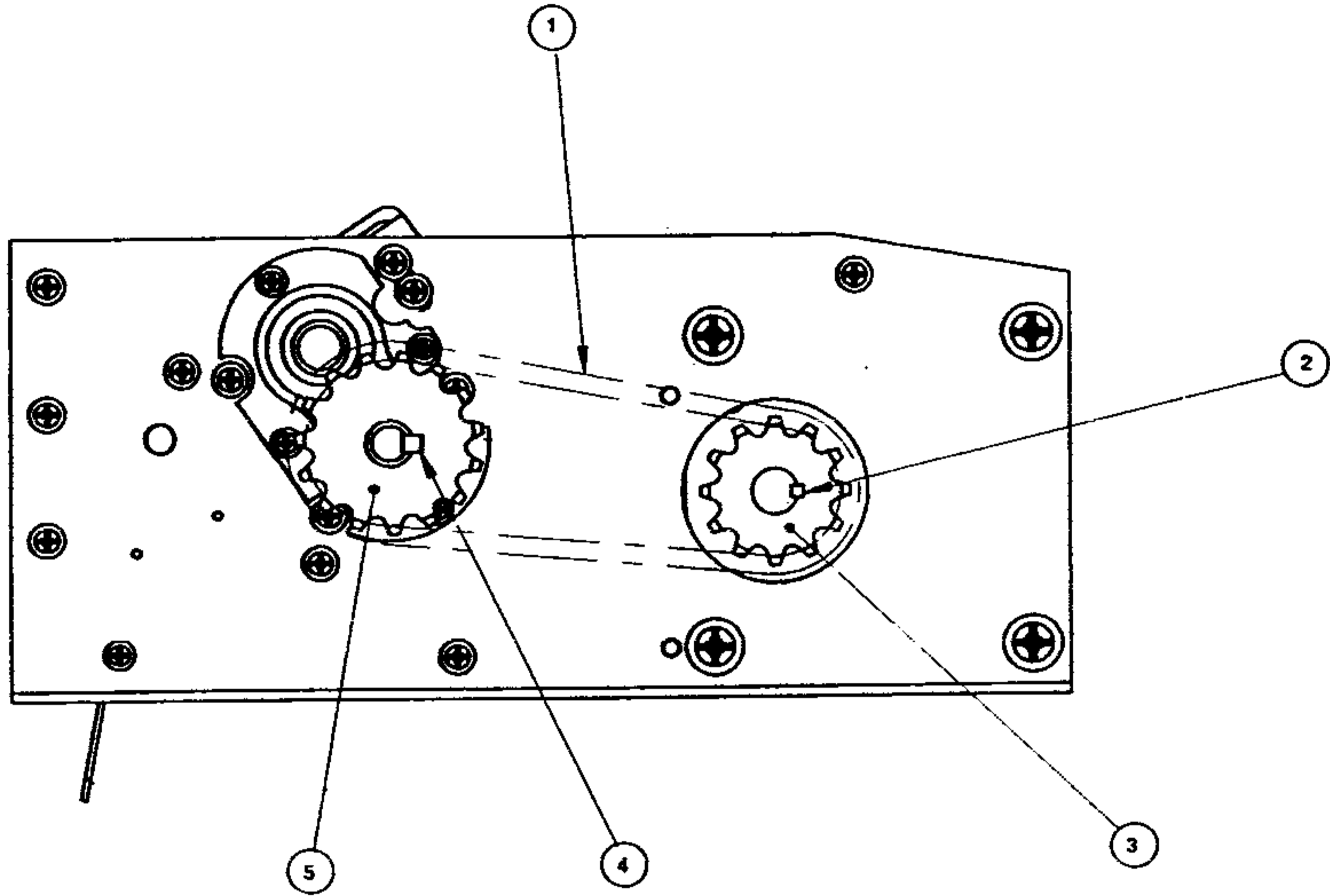

ITEM	PART NO.	DESCRIPTION	QTY.
1	6186000	CHAIN	1
2	1852818	KEY 1/8 SQUARE X 5/8 LONG	1
3	6181000	12T SPROCKET, MOTOR	1
5	6181001	15T SPROCKET, CUTTER	1

**8.0 PARTS**  
**Figure 8.5**

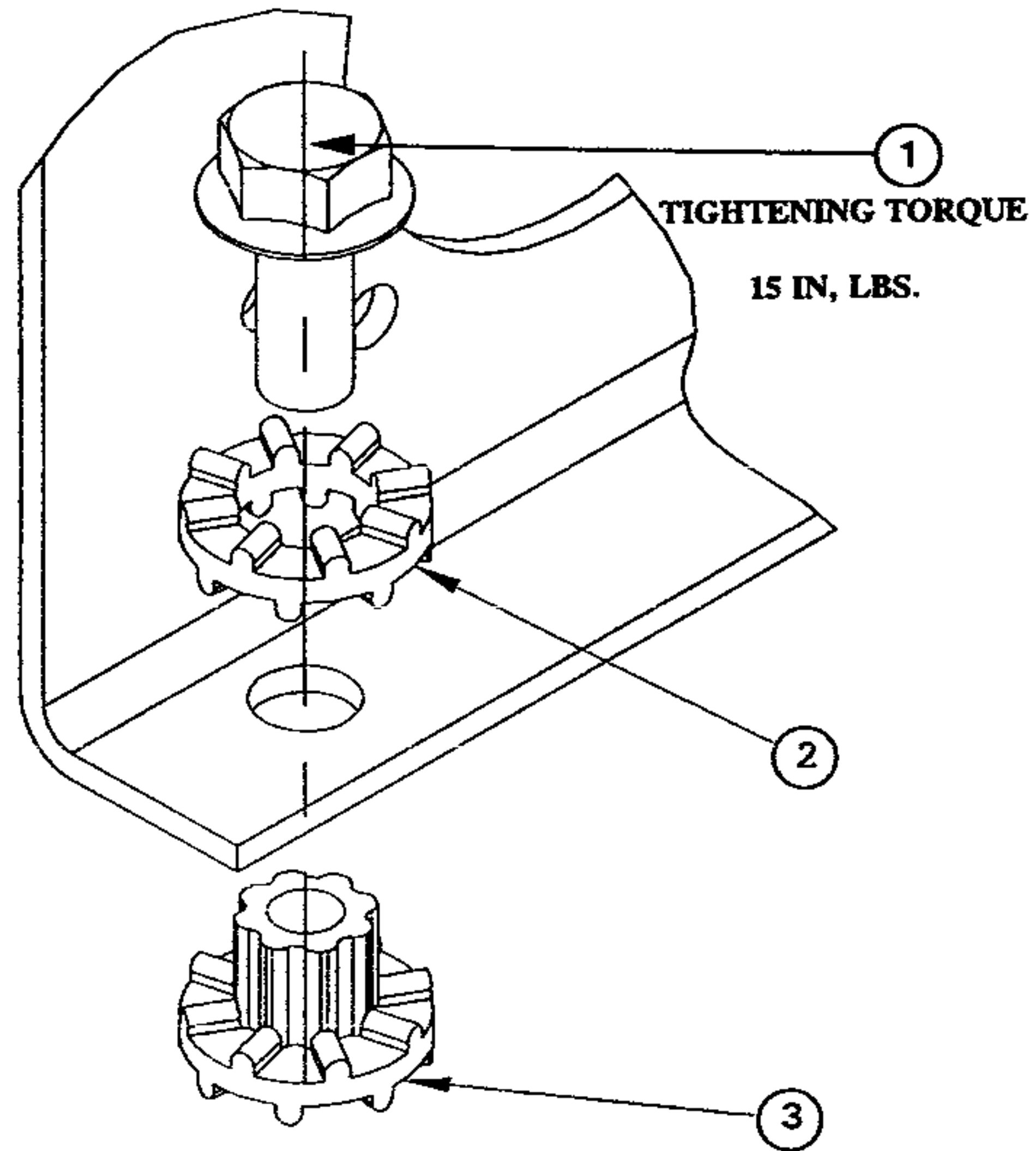

PARTIAL VIEW  
CUTTING HEAD MOUNTING HOLES

ITEM	PART NO.	DESCRIPTION	QTY.
1	1903202	SCREW 5/16-18 X 1.5 FLANGE NO.	4
2	7500489	RING, 1S0DAMP	4
3	7500490	BUSHING, 1S0DAMP	4

8.0 PARTS  
Figure 8.6

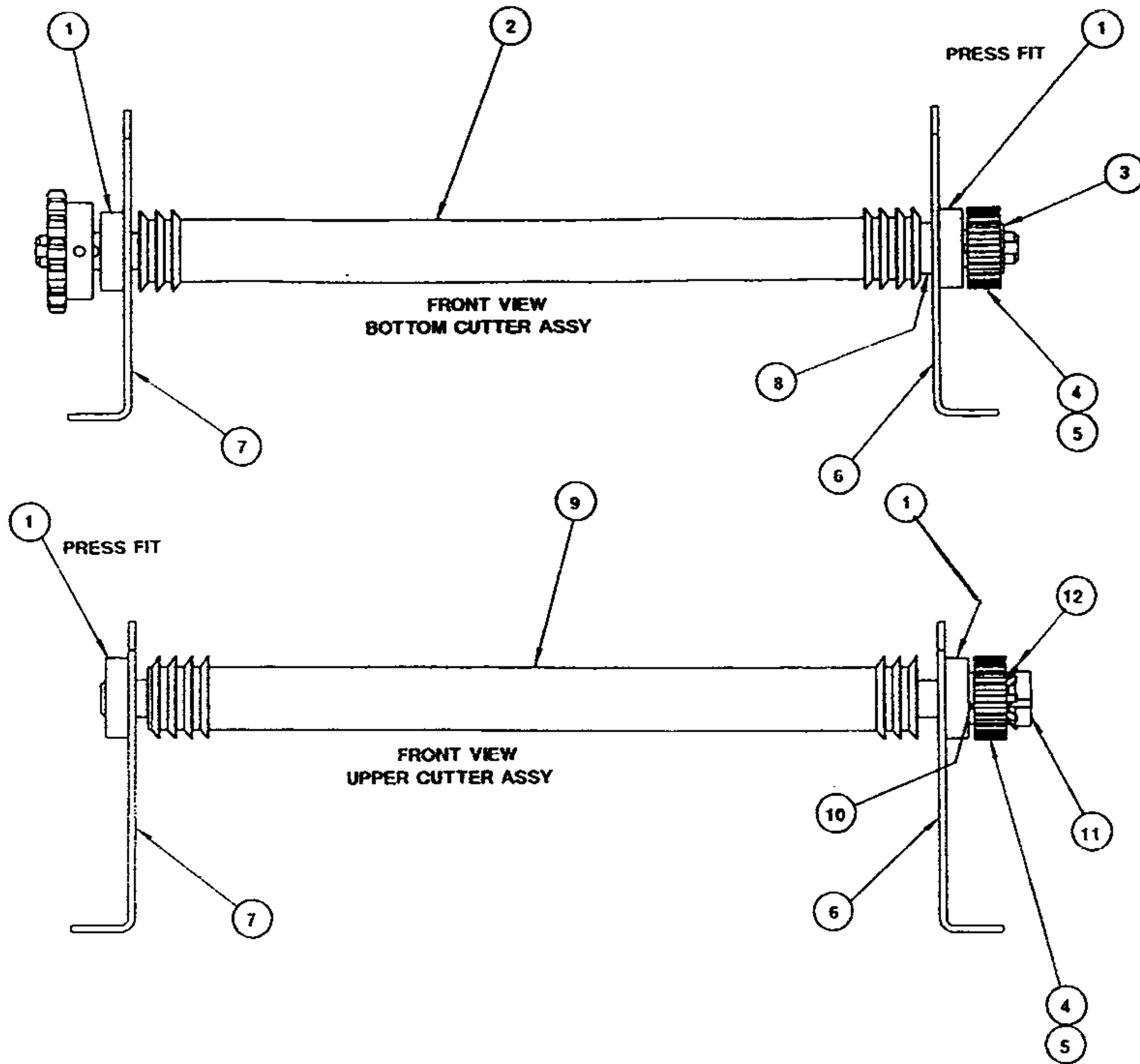

ITEM#	PART NO.	DESCRIPTION	QTY.
1	6173004	BALL BEARING, CUTTER	4
2	7500485	LOWER CUTTER	1
3	1931604	GRIP RING 1/2" DIA.	1
4	1132547	GEAR, CUTTER	2
5	1852817	KEY 3/16 SQUARE X 3/8 LONG	2
6	7500482	TAIL STOCK	1
7	7500479	HEAD STOCK	1
8	7500484	SPACER	1
9	7500487	UPPER CUTTER	1
10	7500483	SPACER	1
11	1130993	LOCK NUT	1
12	1130994	LOCK WASHER	1

### 5.1 "Wiring Diagram"

